

STRAIGHT BULKHEAD JACK PANEL SEAL
SOLDER TYPE - CABLE .085

R161.335.200
SERIES N

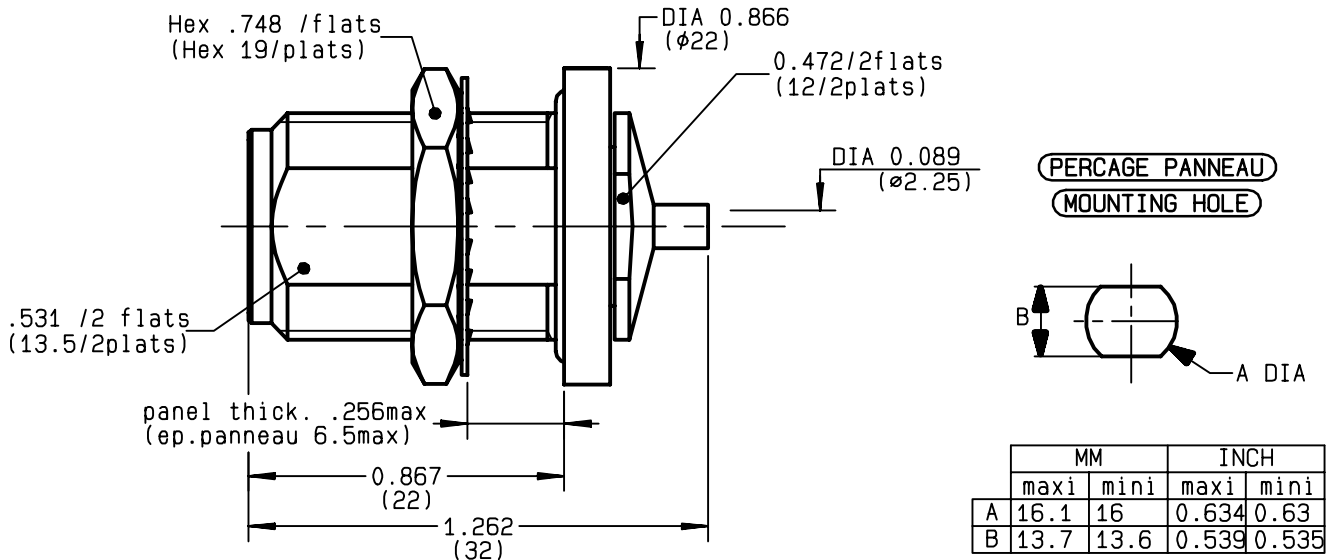

NOMINAL IMPEDANCE	50	Ω
FREQUENCY RANGE	0-11	GHz
TEMPERATURE RATING	-55/+105	$^{\circ}C$
V.S.W.R	1.15 +	x F(GHz)Maxi
RF INSERTION LOSS	0.048	\sqrt{F} (GHz) dB Maxi
VOLTAGE RATING	335	Veff Maxi
DIELECTRIC WITHSTANDING VOLTAGE	1000	Veff Mini
INSULATION RESISTANCE	5000	M Ω Mini
HERMETIC SEAL	NA	Atm.cm ³ /s
LEAKAGE (pressurized only)	IP 67	
MECHANICAL DURABILITY	500	Cycles
WEIGHT	34.6	gr
SPECIFICATION		

CABLES : **KS 1**
RG 405

OTHERS CHARACTERISTICS

CABLE RETENTION	200	N Mini
CENTER CONTACT RETENTION		
Axial force - mating end	NA	N Mini
Axial force - opposite end	NA	N Mini
Torque	NA	cm.N Mini
RECOMMENDED TORQUES		
Mating	NA	cm.N
Panel nut	500	cm.N
Clamp nut	150	cm.N

CONNECTOR PARTS	MATERIALS	FINISH	(all values are given in micrometers)
BODY	BRASS	BBR 2	
OUTER CONTACT			
CENTER CONTACT	BERYLLIUM COPPER	GOLD 0.5 OVER NICKEL 2	
INSULATOR	PTFE	-	
GASKET	SILICONE RUBBER	-	
OTHERS PIECES	BRASS	BBR 2	

ISSUE	CREATION DATE	FILE PART-NUMBER
9908A00	15/01/1997	EPC 96-07



GONZALES

The information given here is subject to change without notice.
Design changes may be in order to improve the product .

Connect to the future



R161.335.200

ISSUE 9908A00 SERIES N

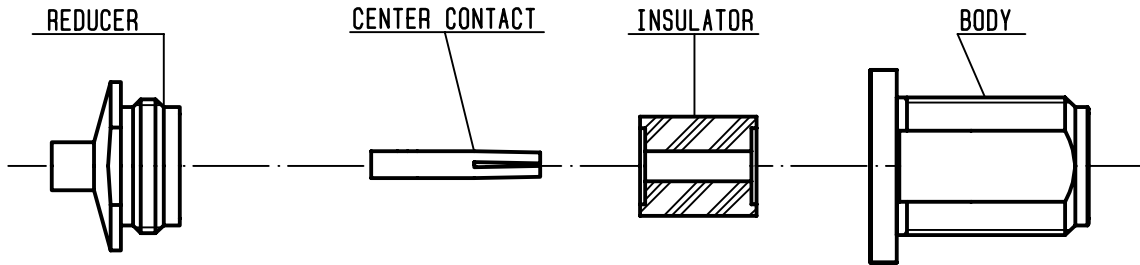

①

Take the tool kit : R 282 125 010 .
Strip the dielectric of the cable .
Stripping tool cable : R 282 051 .
Trimmer : R 282 063.
Clean the cable .
Screw the reducer on the cable

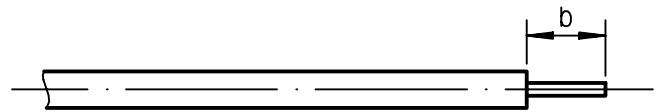

Stripping	a	b	c	d	e
inch	0	0.125 0	0	0	0
mm		3.17			

②

Screw the positioner R282 744 260 onto the soldering jig R 282 740 030 .
Slide contact into positioner .
Insert solder gauge R 282 862 090 between contact and cable .
Tighten and solder the contact .

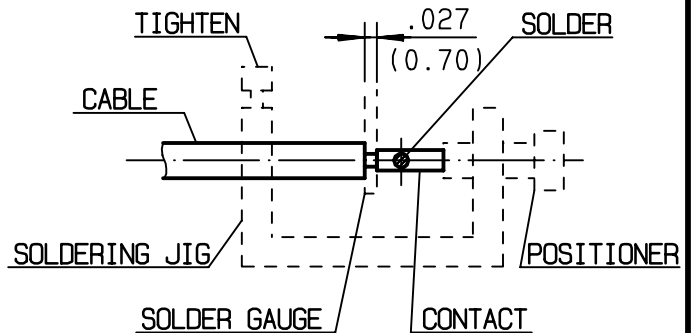

③

After cooling remove cable assembly from the jig .
Put positioner R282 744 310 on the soldering jig .
Slide cable into the reducer until it bottoms againsts positioner R282 744 310 .
Tighten .
Put 3 rings of solder around the cable and solder .
-

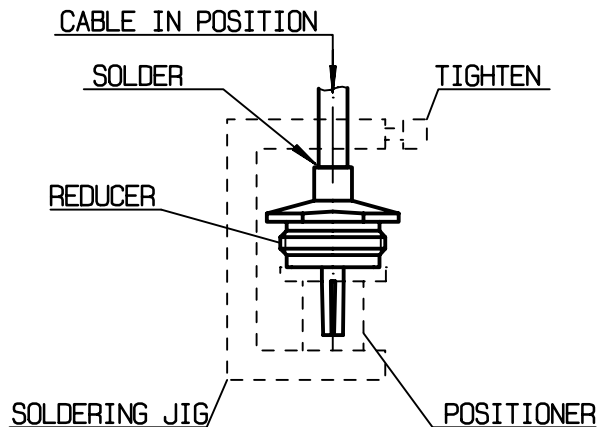

④

After cooling remove cable assembly from the jig .
Slide insulator into the centre contact .
Screw sub-assembly into the connector body .
(recommended coupling torque 13.27 in.lb)

