

REVISIONS					
REV	ECO	DESCRIPTION	DATE	BY	APPR
A1	--	FIRST RELEASED	Aug-30-2018	White	Tommy
A2	--	UPDATED DRAWING	Sep-14-2018	White	Tommy
A3	--	UPDATED DRAWING	Jan-09-2019	White	Tommy

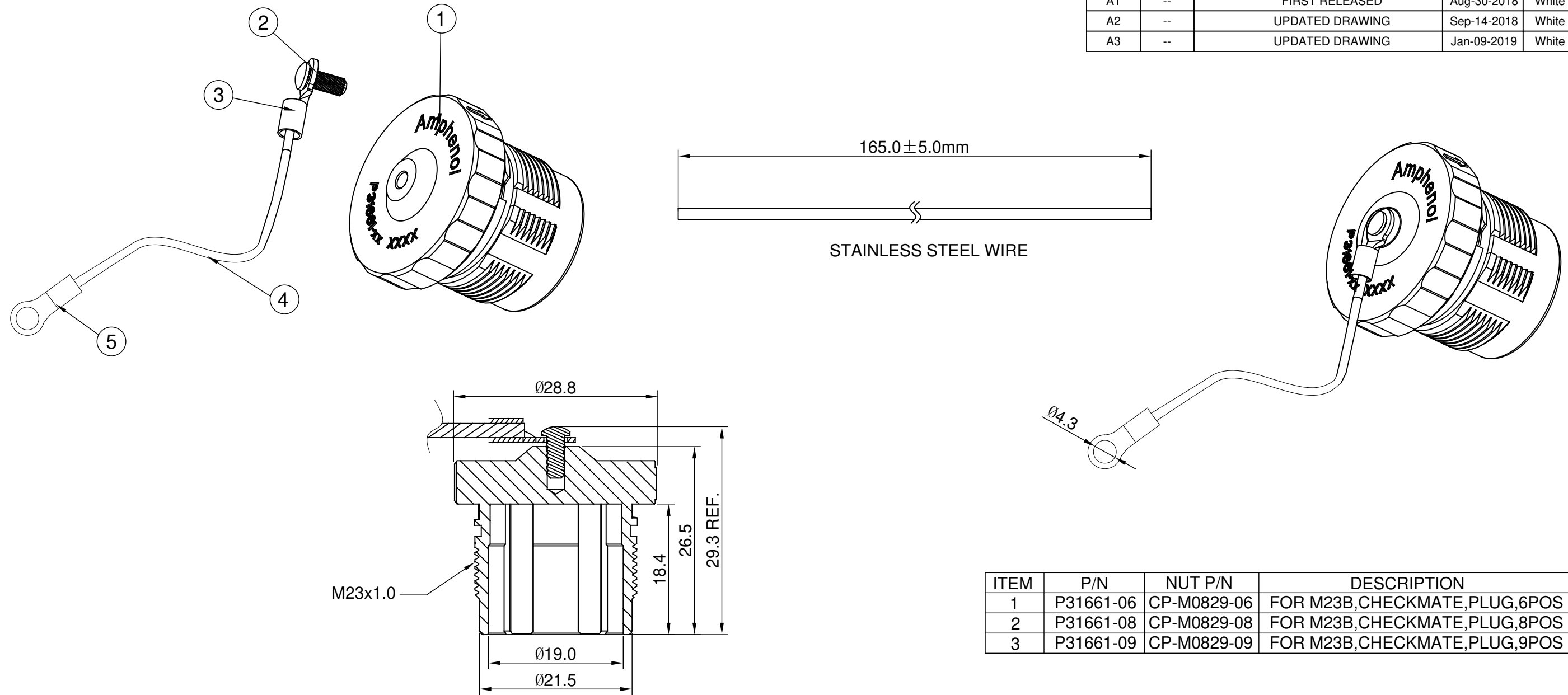

NOTES : (UNLESS OTHERWISE SPECIFIED)

- MATERIAL :
NUT : ZINC DIE CAST, NICKEL PLATED.
RIVET : STAINLESS STEEL.
WIRE : STAINLESS STEEL.
- SPECIFICATIONS :
2.1 MATING CYCLES DURABILITY : 500 CYCLES MIN.
2.2 IP--CLASS : IP67 (IN MATED CONDITION)
2.3 RoHS COMPLIANT.
- ALL DIMENSIONS ARE FOR REFERENCE USE ONLY.

ITEM	P/N	NUT P/N	DESCRIPTION
1	P31661-06	CP-M0829-06	FOR M23B,CHECKMATE,PLUG,6POS
2	P31661-08	CP-M0829-08	FOR M23B,CHECKMATE,PLUG,8POS
3	P31661-09	CP-M0829-09	FOR M23B,CHECKMATE,PLUG,9POS

1	RRNBL14	RING TERMIANL M4	5
165mm	RM0061	STAINLESS STEEL WIRE	4
1	RSC000021	RING TERMIANL M3	3
1	RM0084	RIVET,F2.5*6.35	2
1	SEE TABLE(NUT P/N)	METAL COUPLING NUT	1
QUANTITY	PART NUMBER	DESCRIPTION	ITEM

MATERIALS LIST			
UNLESS OTHERWISE SPECIFIED 1) All dimensions are in metric(mm). 2) Tolerances are as follows: 1 PL DEC ±0.30 2 PL DEC ±0.15 3 PL DEC ±0.08 Fractions ±1/64 Angles ±1° 3) Note reference =		SIGNATURES	DATE
		DRAWN: White	Jan-09-2019
		CHECKED: Tod	Jan-09-2019
		ENGINEER:	
		APPROVAL: Tommy	Jan-09-2019
MATERIAL SPECIFICATIONS:		CUSTOMER:	
PROCESS SPECIFICATIONS:		THIS DRAWING IS SUPPLIED FOR INFORMATION ONLY. DESIGN FEATURES, SPECIFICATIONS AND PERFORMANCE DATA SHOWN HEREON ARE THE PROPERTY OF THE AMPHENOL CORPORATION. NO RIGHTS OF REPRODUCTION ARE IMPLIED. ALL DIMENSIONS ARE SUBJECT TO NORMAL MANUFACTURING VARIATIONS.	
NEXT ASSY:			
SIZE	TYPE	DWG NO.	REVISION
B	C-	P31661-XX	A3
SCALE: NONE		SHEET 1 OF 1	

TITLE: DUST CAP FOR M23B CHECKMATE PLUG

DWG NO:

P31661-XX

REV: A3

SH: 1

OF: 1