

REVISIONS					
REV	ECO	DESCRIPTION	DATE	BY	APPR
B1	-	RELEASED DRAWING	JAN-18-2014	ARROW	TOMMY
B2	-	DESIGN CHANGE	JUL-18-2017	FLAN	TOMMY
B3	-	Update drawing	Jun-21-18	Flan	Tommy

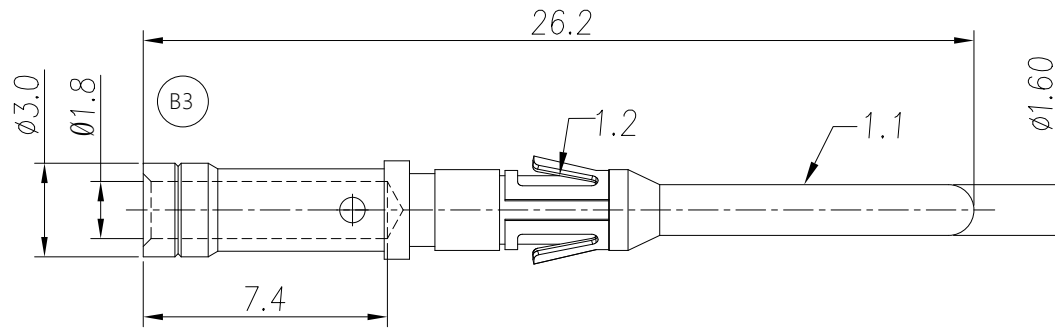

- NOTES: (UNLESS OTHERWISE SPECIFIED)
- MATERIAL:
 - CONTACT BODY: COPPER ALLOY.
 - POSITIONING CLIP: COPPER ALLOY.
 - SPECIFICATIONS:
 - CURRENT RATING: 13A(MAX).
 - TERMINATION TYPE: CRIMPING.
 - WIRE RANGE: 16~18AWG.
 - SUITABLE CONTACT: MS16M23xx.
 - RoHS COMPLIANT.
 - ALL DIMENSIONS ARE FOR REFERENCE USE ONLY.

P/N	CONTACT PLATING(MATING AREA)
MP16M23T	TIN PLATING OVER NICKEL.
MP16M23S	SILVER PLATING OVER NICKEL.
MP16M23F	GOLD FLASH PLATING OVER NICKEL.
MP16M23G5	5μ"GOLD PLATING OVER NICKEL.
MP16M23G10	10μ"GOLD PLATING OVER NICKEL.
MP16M23G15	15μ"GOLD PLATING OVER NICKEL.
MP16M23G30	30μ"GOLD PLATING OVER NICKEL.

QUANTITY	PART NUMBER	DESCRIPTION	ITEM
MATERIALS LIST			
<small>UNLESS OTHERWISE SPECIFIED</small> 1) All dimensions are in metric(mm). 2) Tolerances are as follows: 1 PL DEC ±0.30 2 PL DEC ±0.15 3 PL DEC ±0.08 Fractions ±1/64 Angles ±1° 3) Note reference =		SIGNATURES DRAWN: Flan CHECKED: Tod ENGINEER: APPROVAL: Tommy DATE Jun-21-18 Jun-21-18 Jun-21-18	Amphenol Sine Systems - www.amphenol-sine.com 44724 Morley Drive Clinton Township, MI 48036
MATERIAL SPECIFICATIONS: PROCESS SPECIFICATIONS: NEXT ASSY:		CUSTOMER: THIS DRAWING IS SUPPLIED FOR INFORMATION ONLY. DESIGN FEATURES, SPECIFICATIONS AND PERFORMANCE DATA SHOWN HEREON ARE THE PROPERTY OF THE AMPHENOL CORPORATION. NO RIGHTS OF REPRODUCTION ARE IMPLIED. ALL DIMENSIONS ARE SUBJECT TO NORMAL MANUFACTURING VARIATIONS.	ECO-MATE, PIN CONTACT MACHINE, 16-18AWG, SIZE 16 SIZE: B TYPE: C- DWG NO: MP16M23xx REVISION: B3 SCALE: NONE SHEET 1 OF 1

TITLE: ECO-MATE PIN CONTACT MACHINE, 16-18AWG, SIZE 16
 DWG NO: MP16M23xx
 REV: B3
 SH: 1
 OF: 1