

PRODUCT NUMBER
SEE TABLE

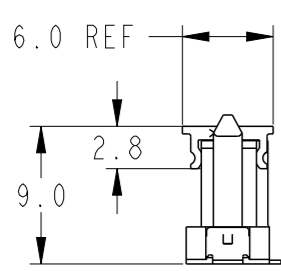
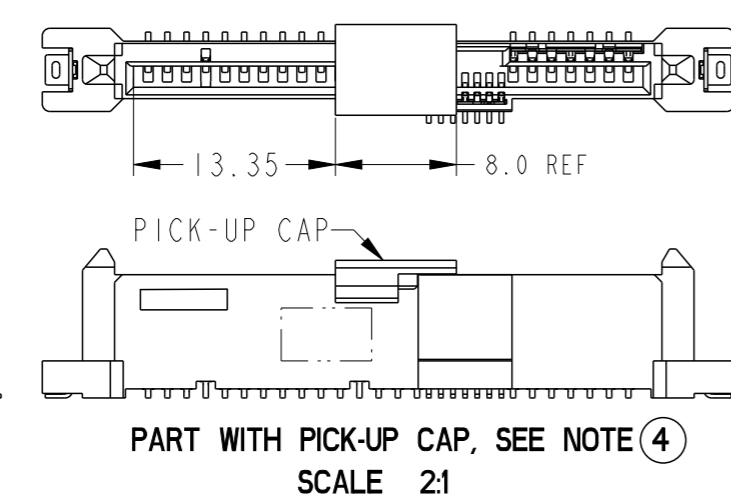
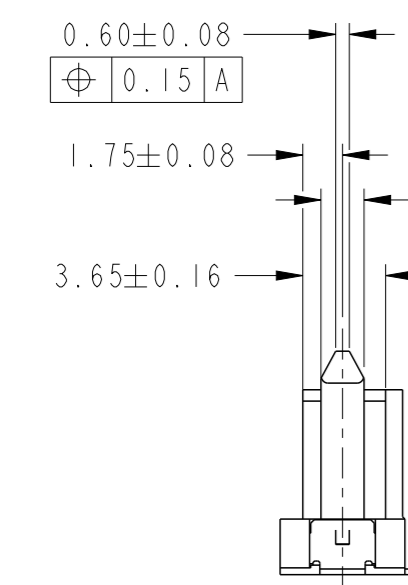
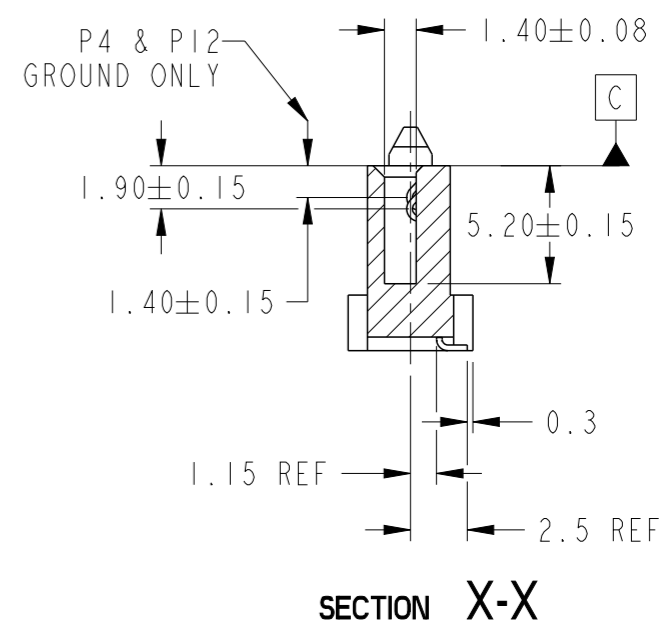
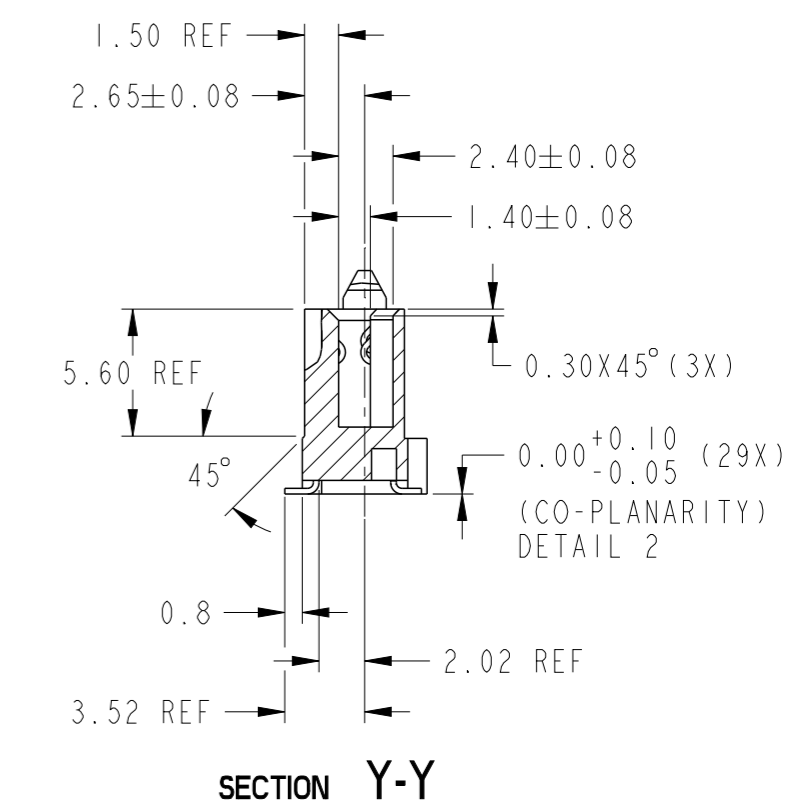
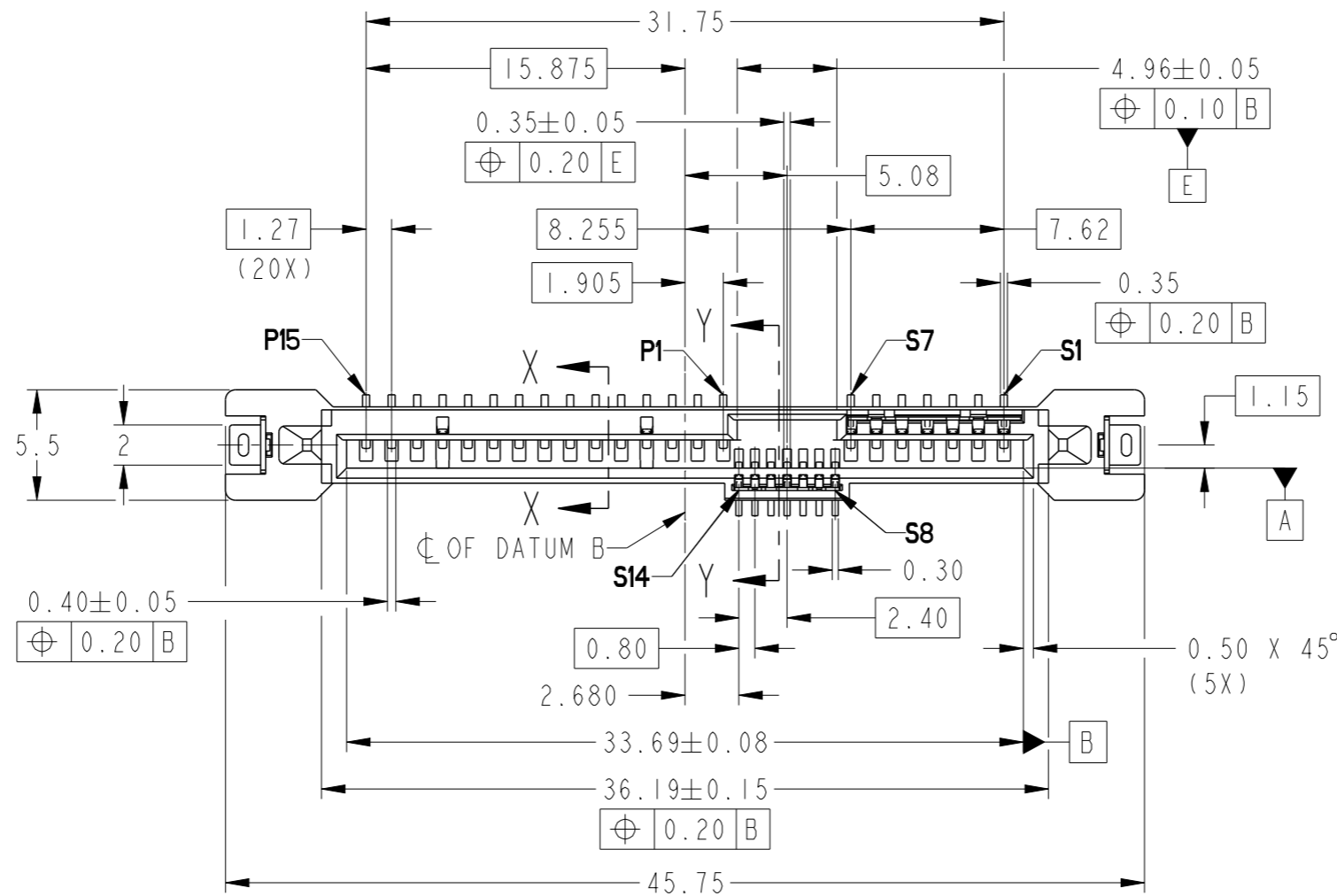

spec ref	-	dr	S Paulpandian	2013/03/13	projection	mm	size	A3	scale	3:1
tolerance std	ISO 406 ISO 1101	eng	Noorhazelinda	2016/11/23		mm	ecn no	ELX-M-25420-1	rel level	Released
TOLERANCES UNLESS OTHERWISE SPECIFIED		chr	-	apppr						
surface	linear	0.X	±0.20			12G SAS RECEPTACLE VERTICAL SMT TYPE ASSY	dwg no	10120998	rev	C
	angular	0°	±2°							

TOLERANCES UNLESS OTHERWISE SPECIFIED				12G SAS RECEPTACLE VERTICAL SMT TYPE ASSY		dwg no	10120998	rev	C
surface	linear	0.X	±0.20	cat. no.	-	Product - Customer Drw	sheet 1 of 2		
	angular	0°	±2°						

© 2016 AFCI
 Amphenol FCI

PRODUCT NUMBER	METAL CLIP	PLATING	PICK-UP CAP	PACKAGING	REMARKS	PRODUCT NUMBER	PLATING
10120998-001LF	2 PCS	NOTE ②	NO	TRAY	NOTE ⑧	10120998-401LF	NOTE ⑩
10120998-001CLF			YES		NOTE ④ & ⑧	10120998-401CLF	
10120998-001C-TRLF			YES	TAPE & REEL	NOTE ④ ⑥ & ⑧	10120998-401C-TRLF	

NOTES:

1. MATERIAL :
 1) HOUSING : HIGH TEMP THERMOPLASTIC, UL 94V-0
 COLOR : BLACK
 2) TERMINAL : COPPER ALLOY
 3) HOLD DOWN : COPPER ALLOY
- ② FINISH :
 1) TERMINAL : 30μ" Au PLATING (CONTACT POINT) OVER 50μ" NICKEL
 2) SOLDER TAIL : 100μ" MIN Sn OVER 50μ" NICKEL
 3) HOLD DOWN : 100μ" MIN Sn OVER 50μ" NICKEL
3. PER SFF REV 1.1, EXCEPT 0.8mm PITCH BUMP AREA.
- ④ PART WITH PICK-UP CAP, P/N XXXXXXXX-XXXC LF.
5. THE STD PACKAGING IS IN TRAY UNLESS OTHERWISE SPECIFIED.
- ⑥ PART NUMBER WITH SUFFIX "-TR" MEANS FOR TAPE & REEL PACKAGING (E.G. P/N: XXXXXXXX-XXXC-TRLF).
7. THE HOUSING WILL WITHSTAND EXPOSURE TO 260°C PEAK TEMPERATURE FOR 10 SECONDS IN A CONVECTION, INFRA-RED OR VAPOR PHASE REFLOW OVEN.
- ⑧ THIS PRODUCT MEETS EUROPEAN UNION DIRECTIVES AND OTHER COUNTRY REGULATIONS AS DESCRIBED IN GS-47-0004.
9. PART NUMBERS ENDING IN "LF" MEANS FOR NOTE 8 LEAD FREE IDENTIFICATION
- ⑩ FINISH :
 1) TERMINAL : 15μ" GXT PLATING (CONTACT POINT) OVER 50μ" NICKEL
 2) SOLDER TAIL : 100μ" MIN Sn OVER 50μ" NICKEL
 3) HOLD DOWN : 100μ" MIN Sn OVER 50μ" NICKEL
11. A $\triangle C$ SYMBOL WILL BE NEXT TO ANY DIMENSION, VIEW, OR NOTE WHICH HAS BEEN MODIFIED WITH THE CURRENT DRAWING REVISION.
- ⑫ DATE CODE LOCATION. DATE CODE NO.YYWW (E.G. 14225).

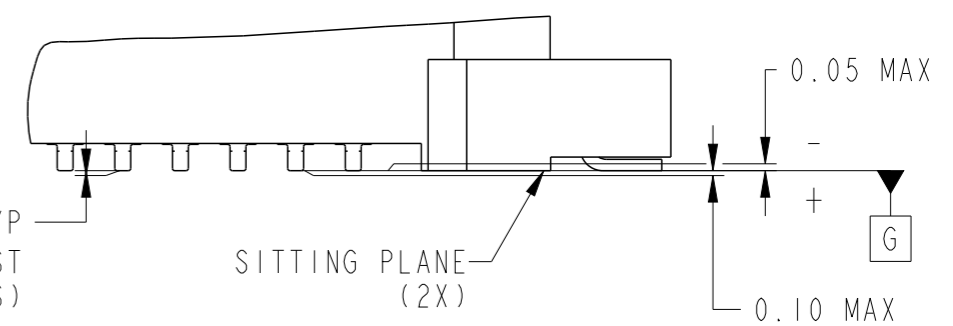
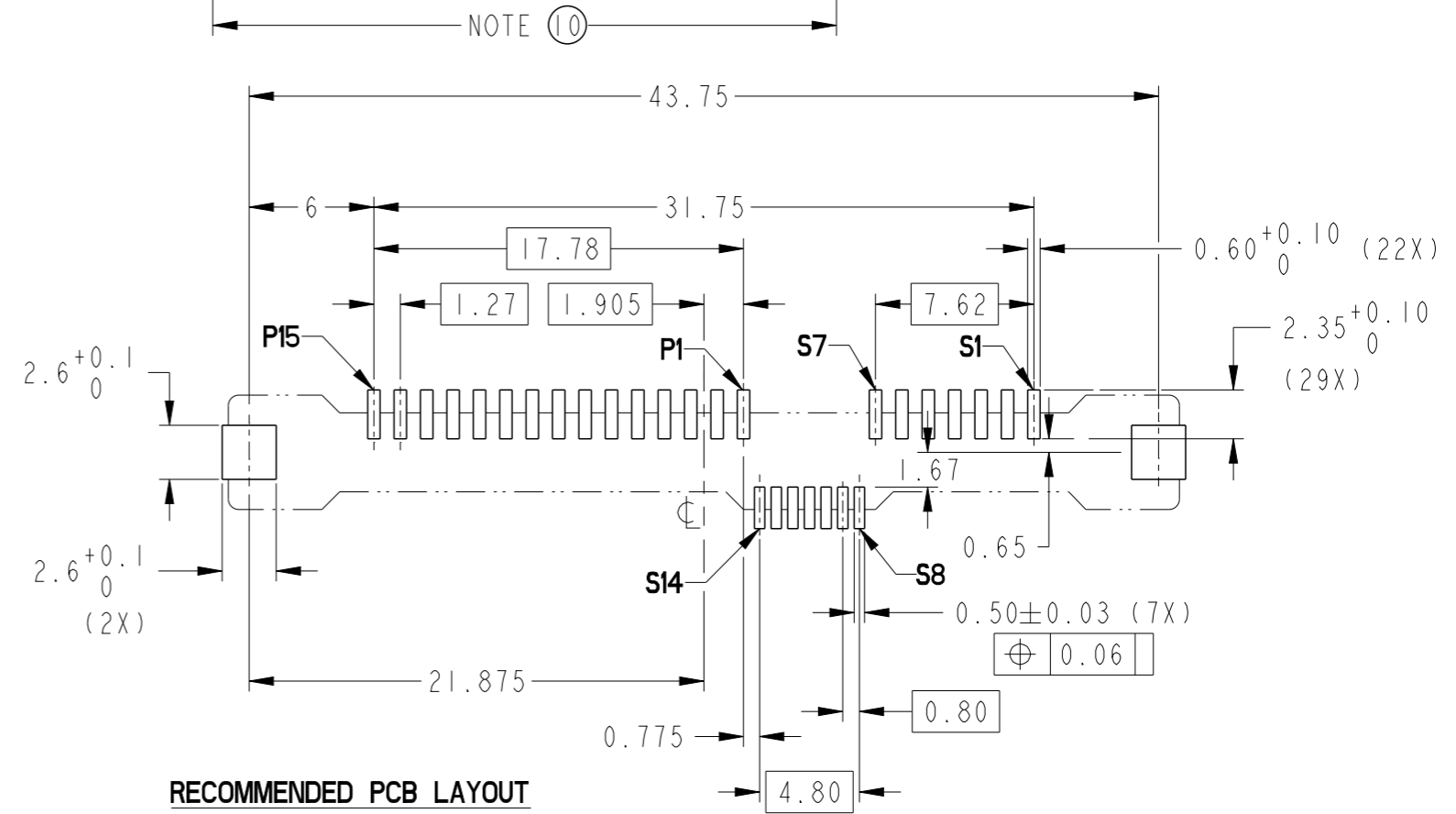

DETAIL 2
SCALE 6:1

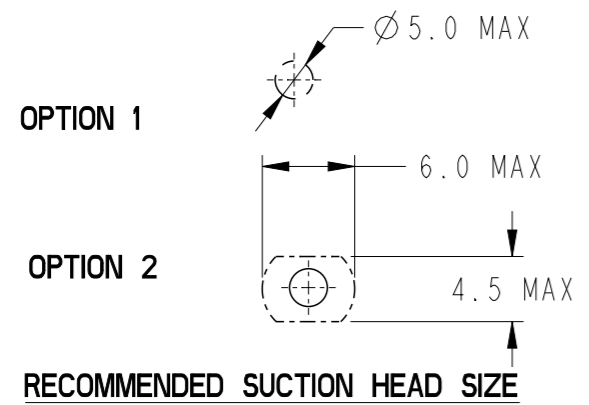

spec ref	-	dr	S Paulpandian	2013/03/13	projection	mm	size	A3	scale	3:1
tolerance std	ISO 406 ISO 1101	eng	Noorhazlinda	2016/11/23			ecn no	ELX-M-25420-1		
surface	linear	chr	-	apppr			Koon-Poh Tay	2016/12/01	product family	SAS
	angular	0°	±2°	Amphenol FCI		cat. no.	-	Product - Customer Drw	sheet 2 of 2	
		0.X	±0.20	12G SAS RECEPTACLE		dwg no	10120998	rev	C	
		0.XX	±0.20	VERTICAL SMT TYPE ASSY						
		0.XXX	±0.20							

Amphenol FCI

© 2016 AFCI