

ebn-popst MFG. NOTES

1 LEAD DIMENSION IS AT FULL EXTENSION

| REV. | EC #  | REVISION DESCRIPTION                     | DATE     | D.ENG. | CHECKER |
|------|-------|--|----------|--------|---------|
| 001  | 2888  | RELEASE TO PRODUCTION                    | 06/08/00 | BARB   | MZ      |
| 002  | 6578  | CHANGE 22AWG TO 18AWG. ADD PROD.ID LABEL | 09/22/04 | DTM    | DW      |
| 003  | 10008 | CHANGE LEAD LENGTH TO 72" (WAS 36")      | 08/05/16 | DTM    | DTM     |

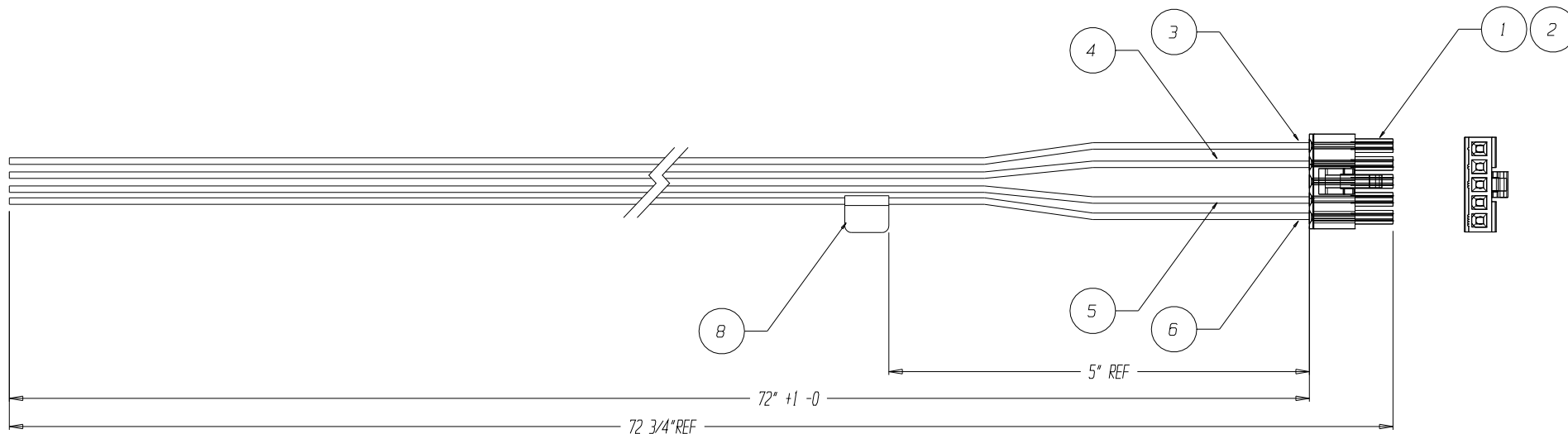

| LEAD PIN CALLOUT |              |
|------------------|--------------|
| PIN 1            | RED          |
| PIN 2            | WHITE        |
| PIN 3            | -----NC----- |
| PIN 4            | YELLOW       |
| PIN 5            | BLUE         |

WIRE TIE USED TO BUNDLE WRAP

| ITEM | QTY | PART NUMBER | DESCRIPTION                   |
|------|-----|-------------|-------------------------------|
| 8    | 1   | 605-50-2659 | PRODUCT ID LABEL              |
| 7    | 1   | 400-50-0003 | WIRE TIE 4"                   |
| 6    | 1   | 410-18-0011 | BLUE AWG18 LUL1007            |
| 5    | 1   | 410-18-0015 | YELLOW AWG18 LUL1007          |
| 4    | 1   | 410-18-0024 | WHITE AWG18 LUL1007           |
| 3    | 1   | 410-18-0002 | RED AWG18 LUL1007             |
| 2    | 4   | 405-32-0024 | MOLEX 39-00-0059 TERM (REEL)  |
|      | REF | 405-32-0007 | MOLEX 39-00-0060 TERM (LOOSE) |
| 1    | 1   | 405-34-0017 | MOLEX 39-01-4051 CONNECTOR    |

|  |  |  |  |   |  |
|--|--|--|--|---|--|
| <b>ebn-popst Inc. DISCLOSURE</b><br>THIS DOCUMENT IS THE PROPERTY OF ebn-popst Inc. ITS USE IS AUTHORIZED BY ebn-popst Inc. ONLY. ALL QUESTIONS MUST BE REFERRED TO ebn-popst Inc. PERSONNEL: DESIGN ENG., MFG.ENG., AND / OR PURCHASING.<br><br><b>CAUTION:</b> ANY PRINTED COPY IS UNCONTROLLED AND TO BE USED FOR REFERENCE ONLY. REFER TO ebn-popst In. CAD SYS. FOR VERIFICATION.<br><br>Form No. 1073 Rev. H |  | MATERIAL: N/A<br>FINISH: N/A<br>IF APPLICABLE PLACE SECOND FINISH AND DESCRIPTION HERE<br>ALL INNER BEND RADI = 1mm BOTTOM BEND UNLESS OTHERWISE STATED<br>TOLERANCES, UNLESS OTHERWISE STATED:<br>DECIMAL .XXX ± .020 HOLES .XXX ± .003 TOLERANCES FOR CNC FLAT .XXX EXCLUDING HOLE DIA. +/- .010<br>TOLERANCE .XX ± .030 ANGLES ± 1° REF | BEND DEDUCTION N/A<br>COSMETICS PER ebn-popst SPEC-D-1<br>SEE CAD FOR DIMS. NOT SHOWN<br>BREAK ALL SHARP EDGES<br>ALL DIMENSIONS ARE IN INCHES<br> | PART NO. 420-05-0275<br>TITLE DC POWER CONTROL HARNESS<br>FIRST USED ON 420-05-0275<br>DESIGN ENG. DTM<br>ORIG. DATE 05/01/00<br>E# EA-0662 | <b>ebmpapst</b><br>REVISION 003 SHEET 1 OF 1 |
|--|--|--|--|---|--|