

REVISIONS					
P	LTR	DESCRIPTION	DATE	DWN	APVD
	E2	REVISED PER ECR-22-156396	25OCT2022	SS	ES

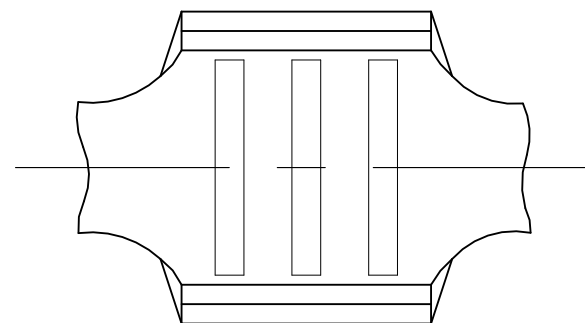

- CONTINUOUS STRIP ON REELS.
- WIRE RANGE: 3300 TO 9000 CMA
- CRIMP WIDTH: .140, "F" TYPE
 CRIMP HEIGHT $(\pm .002) = (\text{TOTAL CMA} + 14,600) / 223,200$
 FOR APPLICATOR INFORMATION CALL: 1-800-722-1111
 FOR PRODUCT INFORMATION CALL: 1-800-522-6752

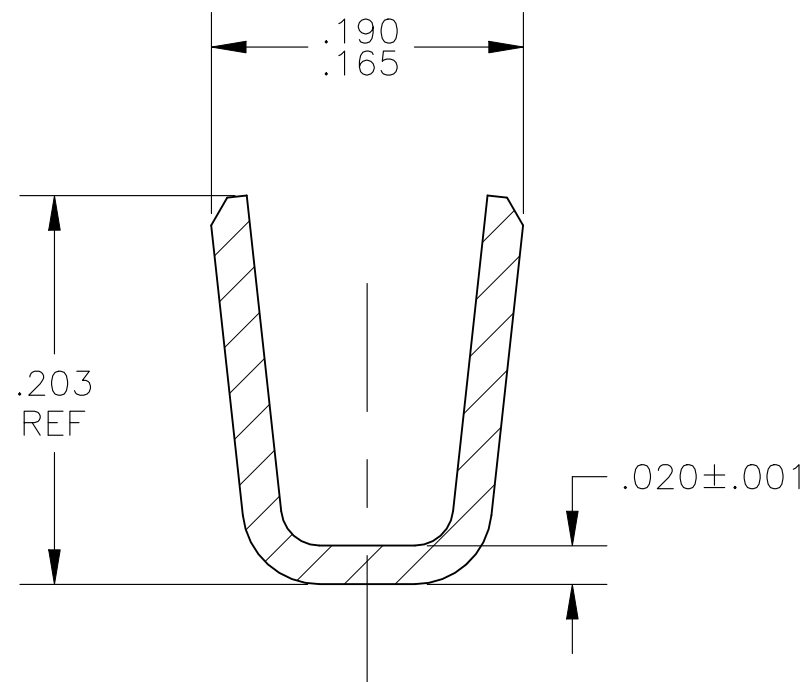
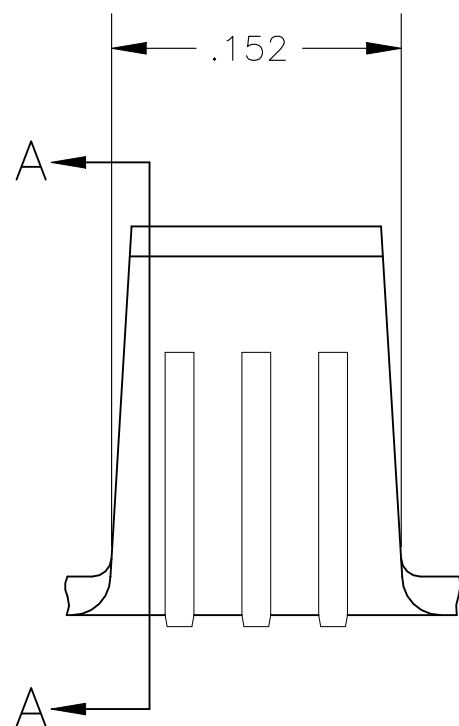

SECTION A-A

---	STAINLESS STEEL	60470-4
BLACKENED	STAINLESS STEEL	60470-1
FINISH	MATERIAL	PART NO

THIS DRAWING IS A CONTROLLED DOCUMENT.		DWN RAGHAVENDRA 03JUL07	STE TE Connectivity														
DIMENSIONS: INCHES		CHK G.D.PORTA 03JUL07															
TOLERANCES UNLESS OTHERWISE SPECIFIED:		APVD G.D.PORTA 03JUL07	NAME														
<table border="0"> <tr><td>0 PLC</td><td>± -</td></tr> <tr><td>1 PLC</td><td>± -</td></tr> <tr><td>2 PLC</td><td>± -</td></tr> <tr><td>3 PLC</td><td>± .010</td></tr> <tr><td>4 PLC</td><td>± -</td></tr> <tr><td>ANGLES</td><td>± -</td></tr> </table>		0 PLC	± -	1 PLC	± -	2 PLC	± -	3 PLC	± .010	4 PLC	± -	ANGLES	± -	PRODUCT SPEC -	SPLICE		
0 PLC	± -																
1 PLC	± -																
2 PLC	± -																
3 PLC	± .010																
4 PLC	± -																
ANGLES	± -																
MATERIAL STAINLESS STEEL		FINISH BLACKEN	APPLICATION SPEC -	SIZE A3	CAGE CODE 00779	DRAWING NO C-60470	RESTRICTED TO -										
CUSTOMER DRAWING			WEIGHT 0.000000	SCALE 10:1	SHEET 1 OF 1	REV E2											