

1

2

3

4

5

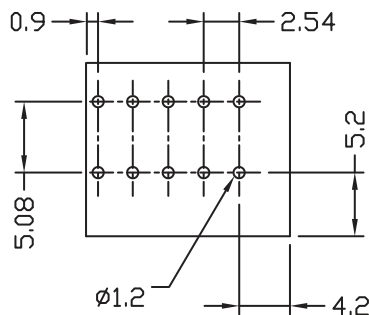

RECOMMENDED PCB LAYOUT - COMPONENT VIEW

TECHNICAL CHARACTERISTICS

MATERIAL
 INSULATOR: PA66
 FLAMMABILITY RATING: UL94-V0
 COLOR: GREEN/ORANGE
 WIRE GUARD: STAINLESS STEEL
 CONTACT: BRASS
 SOLDER TAIL PLATING: TIN

ENVIRONMENTAL
 OPERATING TEMPERATURE: -40°C UP TO 115°C
 COMPLIANCE: LEAD FREE AND ROHS

ELECTRICAL
 CURRENT RATING: 6A
 WORKING VOLTAGE: 150VAC
 WITHSTANDING VOLTAGE: 2.0KV
 CONTACT RESISTANCE: 20 mΩ MAX

STANDARD
 cULus CERTIFIED E315414

MECHANICAL
 SOLID WIRE: 26-20 AWG / 0.129-0.518 MM²
 STRANDED WIRE: 26-20 AWG / 0.129-0.518 MM²

WIRE STRIPE LENGTH: 9-10 MM
 PITCH: 2.54 MM

SOLDERING:
 JEDEC LEAD FREE WAVE SOLDERING

PACKAGING:
 BOX

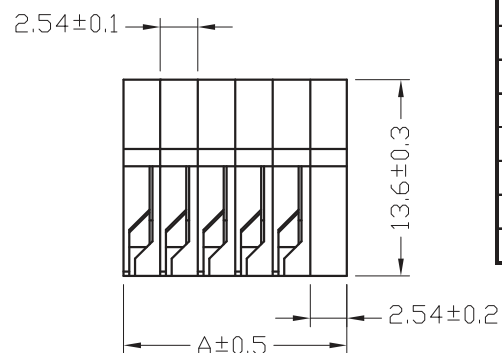
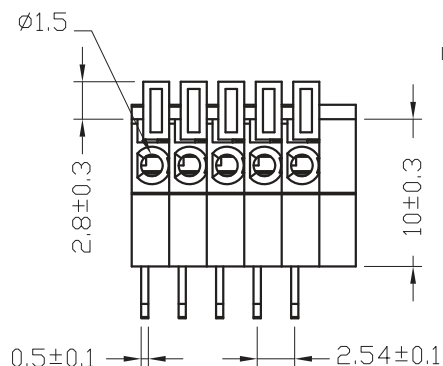
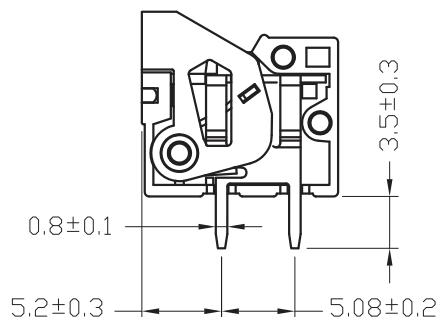

Pitch : 2.54mm			
Poles	A(mm)	Poles	A(mm)
2	7.62	15	40.64
3	10.16	16	43.18
4	12.70	17	45.72
5	15.24	18	48.26
6	17.78	19	50.80
7	20.32	20	53.34
8	22.86	21	55.88
9	25.40	22	58.42
10	27.94	23	60.96
11	30.48	24	63.50
12	33.02	25	66.04
13	35.56		
14	38.10		

RoHS Compliant

PROJECTION:



GENERAL TOLERANCE

.X = +/- 0.2

.XX = +/- 0.15



APPROVAL: FBr

UNIT: MM

SCALE:

SHEET: 1/2

DRAW: AS

DESCRIPTION: SERIE 4029 B - 2.54MM SCREWLESS HORIZONTAL ENTRY
- WR-TBL

WERI PART NO: 691 402 910 0xx B

SIZE

A4

REV	DATE	FILE	BY
G			
F			
E			
D			
C	04-OCT-14	GENERAL UPDATE	AS
B	24-SEP-13	DWG REVIEW	QL
A	02-JUL-12	PDF	GG

1

2

3

4

5

Cautions and Warnings:

This electronic component is designed and developed with the intention for use in general electronics equipments.

Before incorporating the components into any equipments in the field such as aerospace, aviation, nuclear control, submarine, transportation, (automotive control, train control, ship control), transportation signal, disaster prevention, medical, public information network etc. where higher safety and reliability are especially required or if there is possibility of direct damage or injury to human body, Würth Elektronik must be asked for a written approval.

In addition, even electronic component in general electronic equipments, when used in electrical circuits that require high safety, reliability functions or performance, the sufficient reliability evaluation-check for the safety must be performed before by the user before usage.

A

B

C

RoHS Compliant

G				PROJECTION: 	GENERAL TOLERANCE .X = +/- 0.2 .XX = +/- 0.15		
F							
E							
D							
C				APPROVAL: JC	UNIT: MM	DESCRIPTION: DISCLAIMER	SIZE A4
B					SCALE:		
A	10-SEP-14	PDF	QL		SHEET: 2/2	WERI PART NO: DISCLAIMER	
REV	DATE	FILE	BY		DRAW: QL		

D