

LOC	DIST	REVISIONS			
GP	00	REV	DESCRIPTION	DATE	BY
		G	REVISED PER ECR-11-006470	12JUL11	HMR SM
		H	ECR-13-008537	16SEP13	M.T D.Z

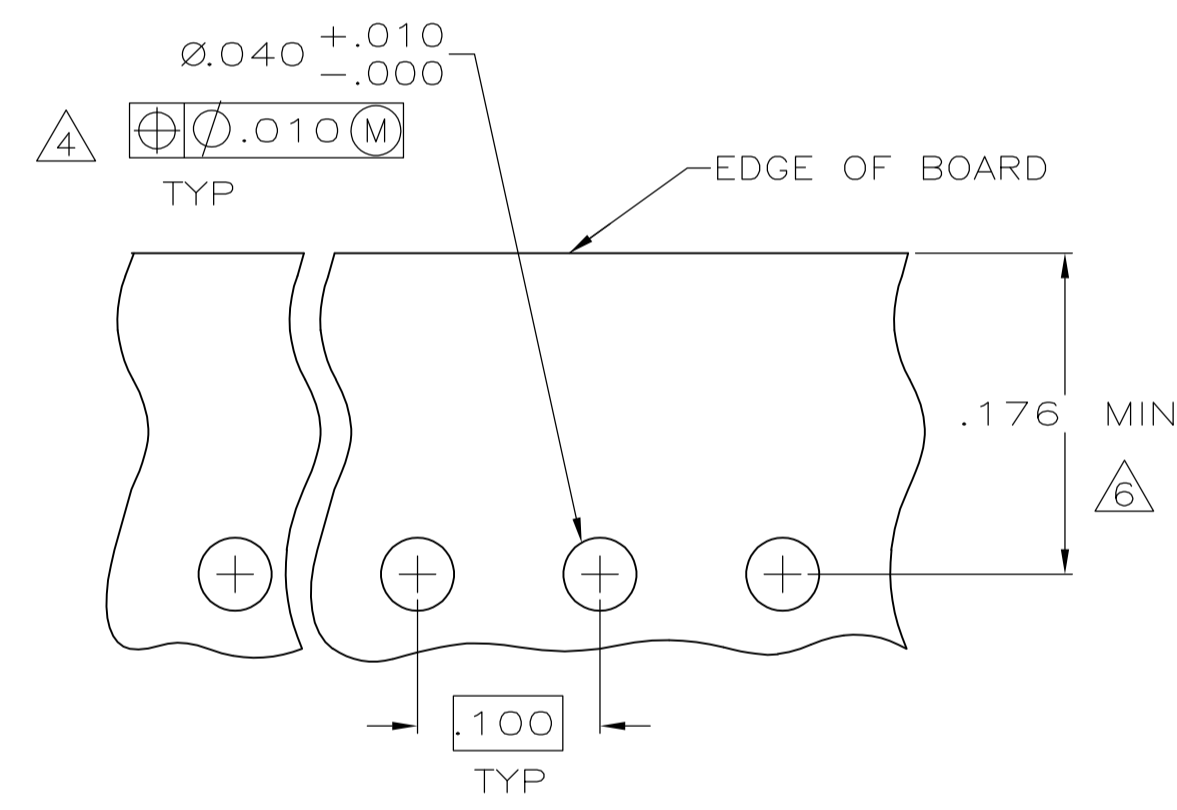
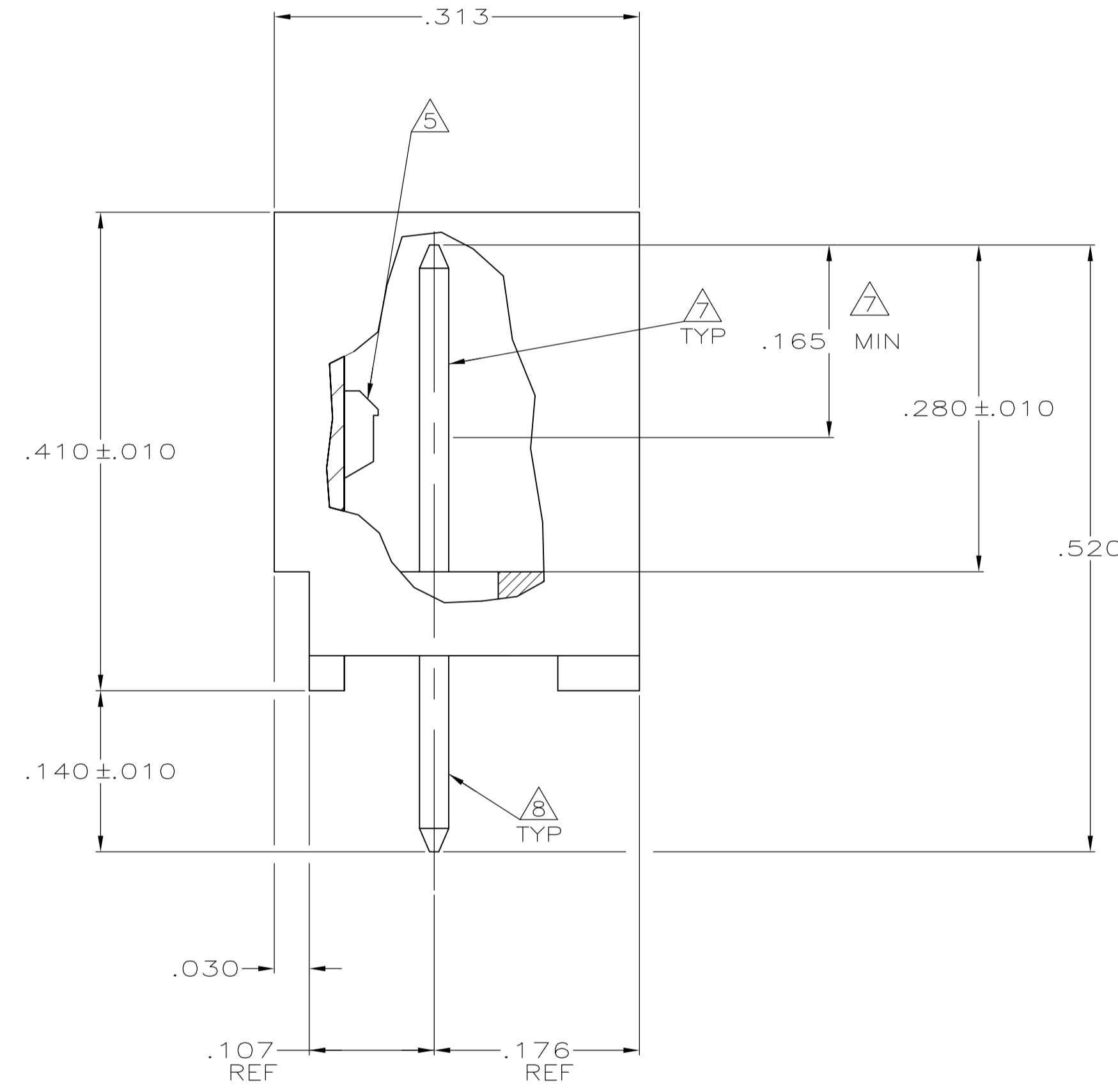
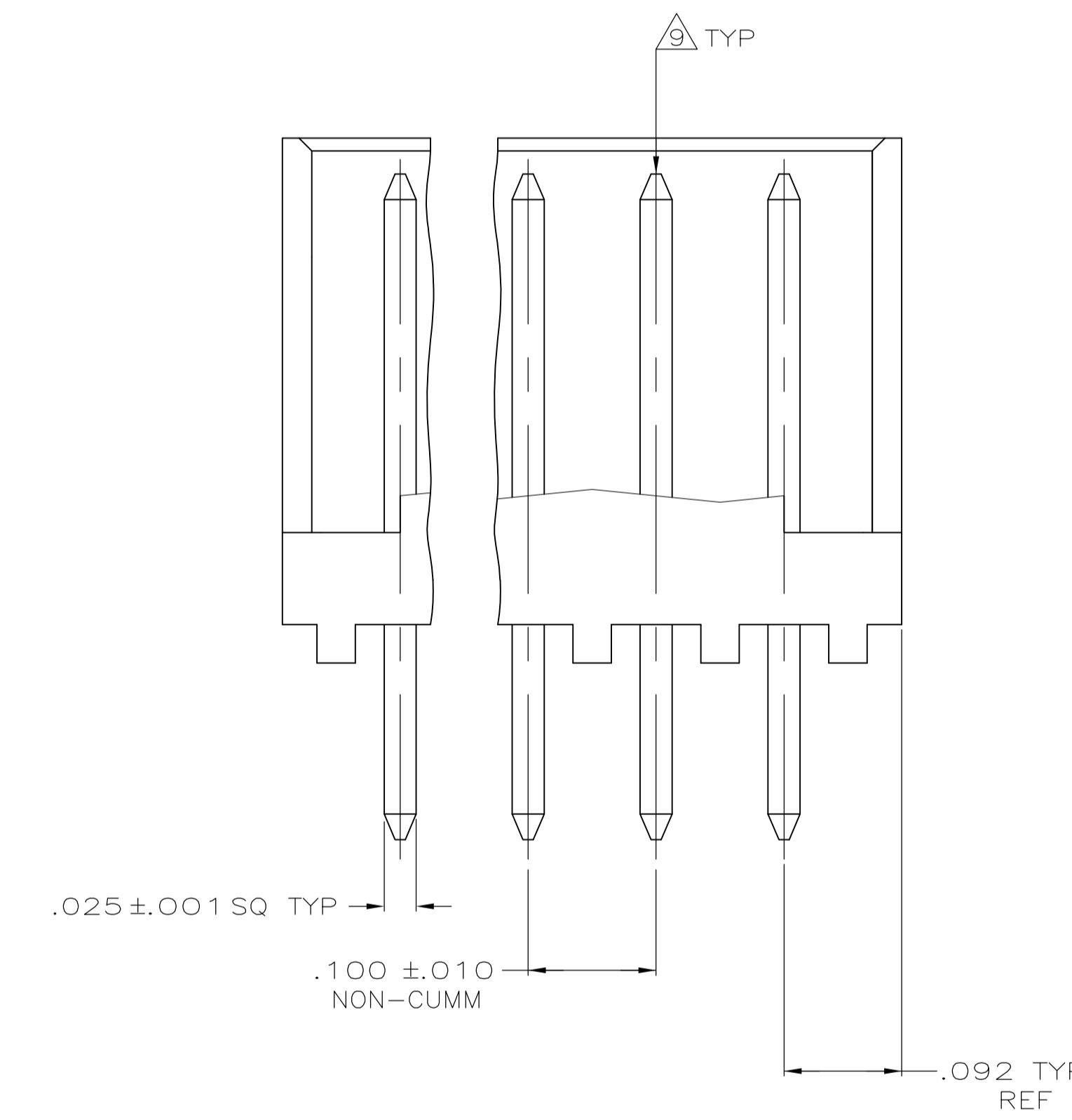
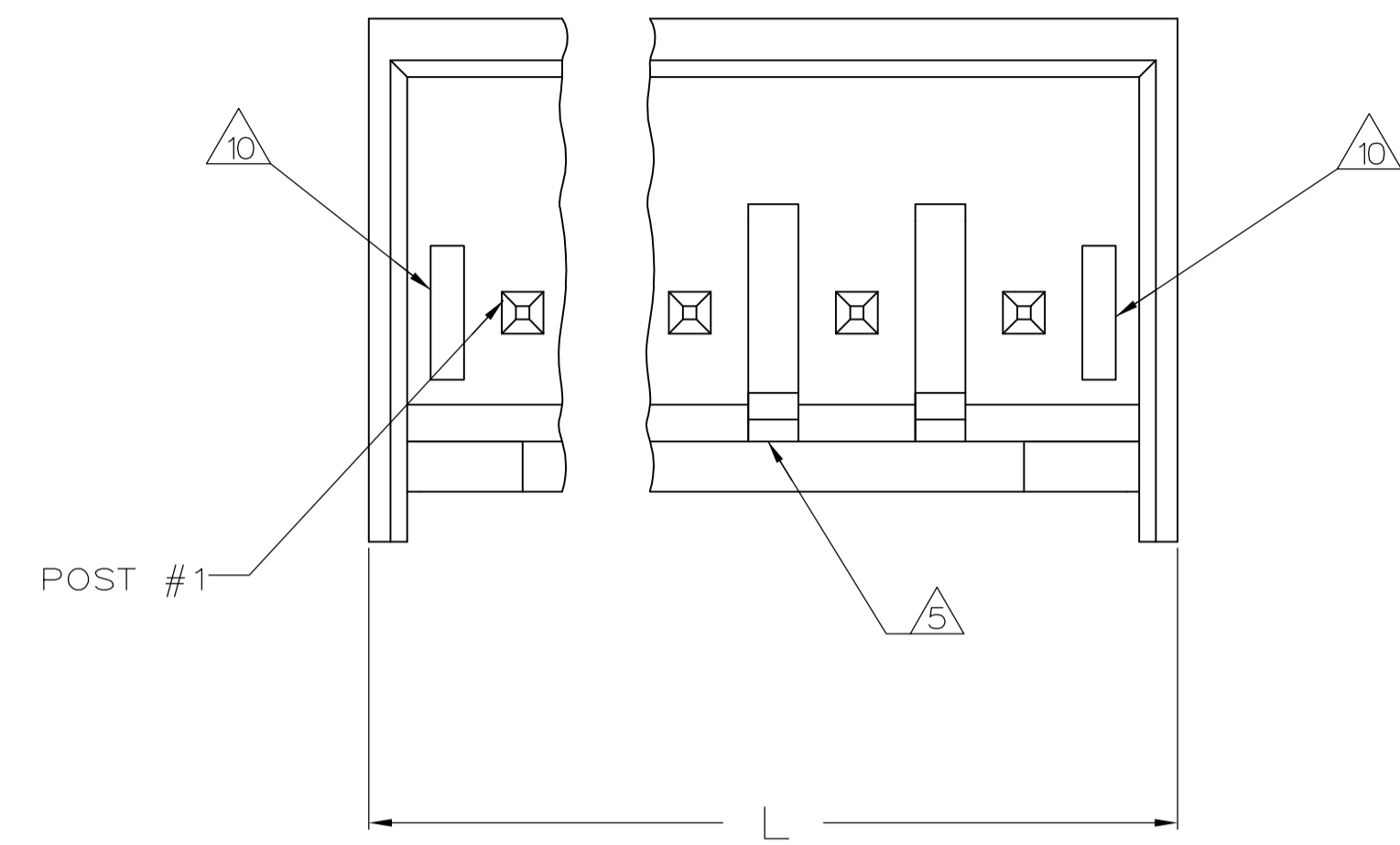

RECOMMENDED MOUNTING HOLE PATTERN FOR .063 THK PRINTED CIRCUIT BOARD

- 1 MATERIAL: HEADER - POLYESTER UL94V-0 (BLACK)  
POST - COPPER ALLOY.
- 2 SOLDER SIDE OF P.C. BOARD SHOWN.
- 3 PARTS COMPLY WITH TYCO ELECTRONICS SOLDERABILITY SPEC 109-11-12 (TIN).
- 4 ONE HOLE MAY BE UNDERSIZED (.032-.035 DIA) FOR ASSEMBLY RETENTION DURING WAVE SOLDERING.
- 5 LATCH DETENT FEATURE OCCURS 2 PLACES ON EACH END (MAXIMUM OF FOUR PER PART). FOR 2 THRU 5 CIRCUIT HEADERS, LATCH FEATURE OCCURS BETWEEN EACH CIRCUIT.
- 6 COORDINATE DIMENSION APPLIES FROM CENTER OF ACTUAL FEATURE.
- 7 GOLD PLATE, .000030 MIN, FOUR SIDES AS SHOWN, OVER NICKEL UNDERPLATE, .000050 MIN, ALL SIDES AND ENTIRE LENGTH OF POST.  
OR  
GOLD FLASH OVER PALLADIUM-NICKEL, .000030 MIN TOTAL THICKNESS AS SHOWN, OVER NICKEL UNDERPLATE .000050 MIN ALL SIDES AND ENTIRE LENGTH OF POST. EITHER PLATING MAY BE PROVIDED AT THE DISCRETION OF TYCO ELECTRONICS.
- 8 TIN PLATING, ALL FOUR SIDES, .140 REF.
- 9 POST MUST WITHSTAND 3.0 LBS (13.34 NEWTONS) MIN FORCE WITHOUT DISLODGING, EITHER DIRECTION.
- 10 SLOTS MAY OR MAY NOT APPEAR ON THESE PARTS.
- 11 MATTE TIN (100%) PLATE, ALL FOUR SIDES, .140 REF.
- 12 UL RECOGNIZED ( UR ) LOGO AND CSA LOGO WILL APPEAR ON THE SIDE OF THE PART. AMP LOGO MAY APPEAR ON THE SIDE OF THE PART OR ON THE BOTTOM OF THE PART.

.010	0.25	.100	2.54	.520	13.21
.005	0.13	.092	2.34	.410	10.41
.001	0.03	.063	1.60	.313	7.95
.000350	0.00889	.040	1.02	.280	7.11
.000150	0.00381	.035	0.89	.176	4.47
.000050	0.00127	.032	0.81	.165	4.19
.000030	0.00076	.030	0.76	.140	3.56
.000	0.00	.025	0.64	.107	2.72
IN	MM	IN	MM	IN	MM

CONVERSION TABLE

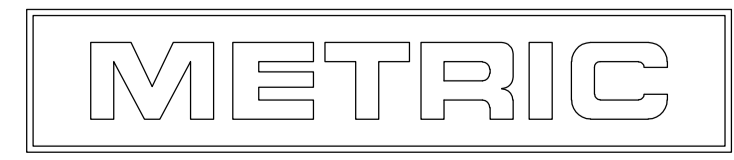

IN	MM	NO OF POSITIONS	PART NUMBER
1.484	37.69	14	4-644896-4
1.384	35.15	13	4-644896-3
1.284	32.61	12	4-644896-2
1.184	30.07	11	4-644896-1
1.084	27.53	10	4-644896-0
.984	24.99	9	3-644896-9
.884	22.45	8	3-644896-8
.784	19.91	7	3-644896-7
.684	17.37	6	3-644896-6
.584	14.83	5	3-644896-5
.484	12.29	4	3-644896-4
.384	9.75	3	3-644896-3
.284	7.21	2	3-644896-2

IN	MM	NO OF POSITIONS	PART NUMBER
1.484	37.69	14	1-644896-4
1.384	35.15	13	1-644896-3
1.284	32.61	12	1-644896-2
1.184	30.07	11	1-644896-1
1.084	27.53	10	1-644896-0
.984	24.99	9	644896-9
.884	22.45	8	644896-8
.784	19.91	7	644896-7
.684	17.37	6	644896-6
.584	14.83	5	644896-5
.484	12.29	4	644896-4
.384	9.75	3	644896-3
.284	7.21	2	644896-2

THIS DRAWING IS A CONTROLLED DOCUMENT.

DIMENSIONS: INCHES TOLERANCES UNLESS OTHERWISE SPECIFIED:

0. PLC	± .005
1. PLC	± .005
2. PLC	± .005
3. PLC	± .005
4. PLC	± .005
ANGLES	± .005

MATERIAL: 1 FINISH: 7, 8, 11

THIS DRAWING IS A CONTROLLED DOCUMENT. DIN K. WHITAKER 27JUNE2005. CHK D. BOSSI 27JUNE2005. APVD D. BOSSI 27JUNE2005. NAME: CST-100 SHROUDED HEADER ASSEMBLY, FRICTION LOCK, STRAIGHT POST, .000030 GOLD. APPLICATION SPEC: PRODUCT SPEC. SIZE: A1. CAGE CODE: 00779. DRAWING NO: 644896. WEIGHT: 0.00779. RESTRICTED TO: CUSTOMER DRAWING. SCALE: 10:1. SHEET: 1 OF 1. REV: H.