

PART NUMBER	REV	TERMINATOR	FEED TYPE	DESCRIPTION
1426643-1	A	LEADMAKER	MECH POST FEED	CUTS CARRIER
1426643-2	A	BENCH	MECH PRE FEED	CUTS CARRIER
1426643-6	A	LEADMAKER	MECH POST FEED	CONTINUOUS CARRIER
7-1426643-1	A	LEADMAKER	MECH POST FEED	-1 AND SPARE PARTS
7-1426643-2	A	BENCH	MECH PRE FEED	-2 AND SPARE PARTS
7-1426643-6	A	LEADMAKER	MECH POST FEED	-6 AND SPARE PARTS
7-1426643-7	A	-	-	SPARE PARTS KIT

CRIMP DATA		DELPHI TERMINAL		DELPHI CRIMP SPECS	
TERMINAL NAME: TAXI TERMINAL F M/P 150 TANG					
CRIMP	SIZE	TYPE	RANGE		
WIRE	1.78 [ .070 IN ]	F	0.35-0.50mm <sup>2</sup>		
INSUL	4.06 [ .160 IN ]	O	1.30-2.20 [ .051- .087 IN ]		
WIRE STRIP LENGTH		APPL INSTRUCTIONS			
5.60 [ .220 IN ]		408-8322			
TERMINAL APPL SPEC		FEED			
-		12.27 [ .483 IN ]			
TERMINALS APPLIED					
TYCO TERM PN	MANUF TERM PN	TYCO SEAL PN	MANUF SEAL PN		
286933-1	12084200	286934-1	12052925		
286933-2	12160222	286934-2	15324974		
286933-3	15326396	1572277-1	12048087		
WIRE SIZE	CRIMP HEIGHT	PINPN & LENGTH [IN]			
0.50mm <sup>2</sup>	0.95 ± 0.05 [ .037 ± .002 IN ]	1-354779-2 [ .3050 ]			
0.35mm <sup>2</sup>	0.85 ± 0.05 [ .033 ± .002 IN ]	2-354779-0 [ .3090 ]			

- △ RECOMMENDED SPARE PARTS.
- 2. GREASE RAM, CAM, CAM FOLLOWER AND FEED ROD LIGHTLY.
- △ CERTAIN TERMINALS REQUIRE LUBRICATION. REFER TO THE APPLICATOR INSTRUCTION SHEET FOR MORE INFORMATION.
- 4. LUBRICATE DAILY PER THE APPLICATOR INSTRUCTION SHEET SUPPLIED WITH THE APPLICATOR.
- △ THIS APPLICATOR APPLIES TERMINAL WITH A SEAL. INSULATION DIA QUOTED IS RANGE OF TERMINAL. WIRE INSULATION DIA IS DEPENDENT ON SEAL BEING APPLIED. SEAL PMS AS SHOWN ABOVE, INS. DIA RANGE IS 1.29-1.70.
- △ APPLY TORQ-SEAL IN ALLEN SOCKET TO FILL HOLE AFTER FLAT HD HAS BEEN ADJUSTED TO CORRECT HEIGHT AT QUALIFICATION. APPLY #1-23419-5 LOC-TITE TO THREADS.
- △ CRIMP DATA SUPPLIED BY THE TERMINAL MANUFACTURER.
- △ SEE DELPHI DATA SHEET FOR SPECIFIC WIRE DETAILS.

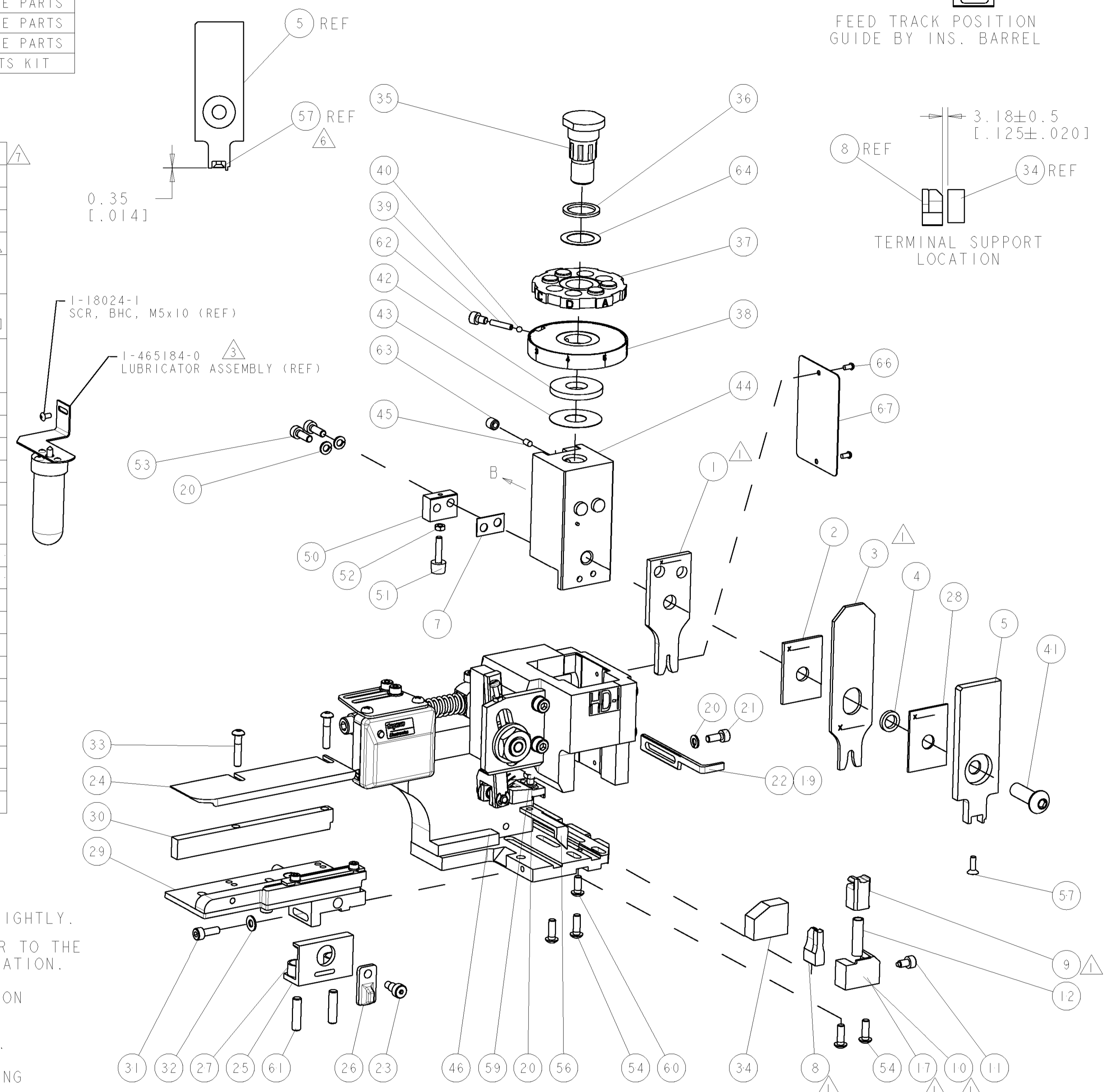
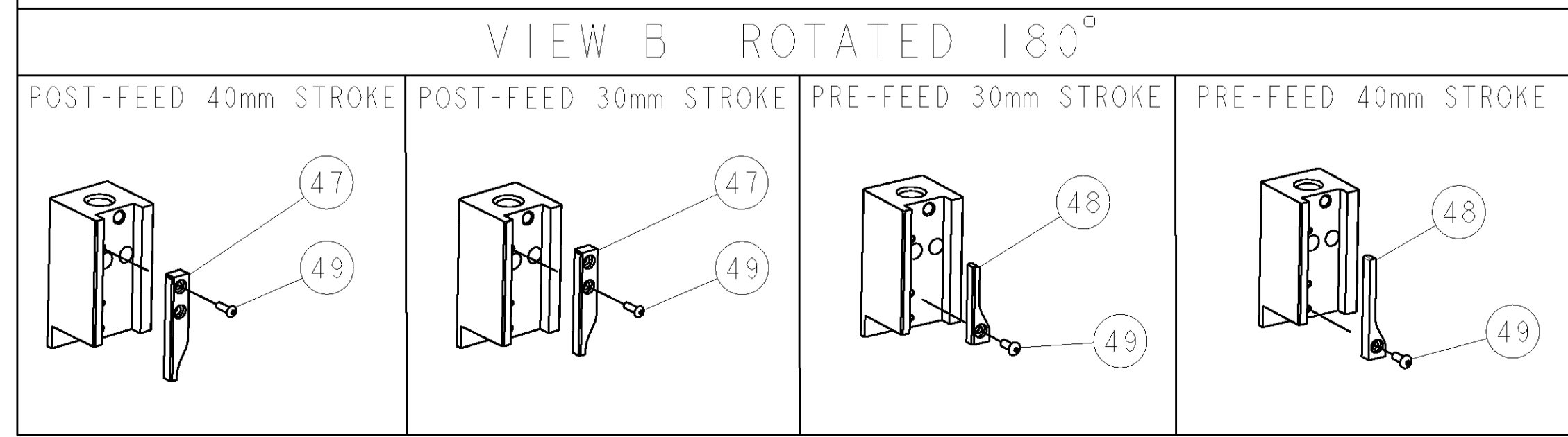

SET UP GAGE 458637-3		LOC	DIST	REVISIONS			
P	LTR	DESCRIPTION	DATE	BY	APPD		
2		DRAWING MODIFIED	11JUL2007	LJL	MC		
A		SEE ECO-07-019468	20AUG2007	LJL	MC		

QTY	UNIT	DESCRIPTION	ITEM NO
-	-	-	73
-	-	-	72
-	-	-	71
-	-	-	70
-	-	-	69
-	-	-	68
-	-	-	67
-	-	-	66
-	-	-	65
-	-	-	64
-	-	-	63
-	-	-	62
-	-	-	61
-	-	-	60
-	-	-	59
-	-	-	58
-	-	-	57
-	-	-	56
-	-	-	55
-	-	-	54
-	-	-	53
-	-	-	52
-	-	-	51
-	-	-	50
-	-	-	49
-	-	-	48
-	-	-	47
-	-	-	46
-	-	-	45
-	-	-	44
-	-	-	43
-	-	-	42
-	-	-	41
-	-	-	40
-	-	-	39
-	-	-	38
-	-	-	37
-	-	-	36
-	-	-	35
-	-	-	34
-	-	-	33
-	-	-	32
-	-	-	31
-	-	-	30
-	-	-	29
-	-	-	28
-	-	-	27
-	-	-	26
-	-	-	25
-	-	-	24
-	-	-	23
-	-	-	22
-	-	-	21
-	-	-	20
-	-	-	19
-	-	-	18
-	-	-	17
-	-	-	16
-	-	-	15
-	-	-	14
-	-	-	13
-	-	-	12
-	-	-	11
-	-	-	10
-	-	-	9
-	-	-	8
-	-	-	7
-	-	-	6
-	-	-	5
-	-	-	4
-	-	-	3
-	-	-	2
-	-	-	1

QTY	UNIT	DESCRIPTION	ITEM NO
-	-	-	84
-	-	-	83
-	-	-	82
-	-	-	81
-	-	-	80
-	-	-	79
-	-	-	78
-	-	-	77
-	-	-	76
-	-	-	75
-	-	-	74

QTY	UNIT	DESCRIPTION	ITEM NO
-	-	-	84
-	-	-	83
-	-	-	82
-	-	-	81
-	-	-	80
-	-	-	79
-	-	-	78
-	-	-	77
-	-	-	76
-	-	-	75
-	-	-	74

QTY	UNIT	DESCRIPTION	ITEM NO
-	-	-	84
-	-	-	83
-	-	-	82
-	-	-	81
-	-	-	80
-	-	-	79
-	-	-	78
-	-	-	77
-	-	-	76
-	-	-	75
-	-	-	74

QTY	UNIT	DESCRIPTION	ITEM NO
-	-	-	84
-	-	-	83
-	-	-	82
-	-	-	81
-	-	-	80
-	-	-	79
-	-	-	78
-	-	-	77
-	-	-	76
-	-	-	75
-	-	-	74

QTY	UNIT	DESCRIPTION	ITEM NO
-	-	-	84
-	-	-	83
-	-	-	82
-	-	-	81
-	-	-	80
-	-	-	79
-	-	-	78
-	-	-	77
-	-	-	76
-	-	-	75
-	-	-	74

QTY	UNIT	DESCRIPTION	ITEM NO
-	-	-	84
-	-	-	83
-	-	-	82
-	-	-	81
-	-	-	80
-	-	-	79
-	-	-	78
-	-	-	77
-	-	-	76
-	-	-	75
-	-	-	74

QTY	UNIT	DESCRIPTION	ITEM NO
-	-	-	84
-	-	-	83
-	-	-	82
-	-	-	81
-	-	-	80
-	-	-	79
-	-	-	78
-	-	-	77
-	-	-	76
-	-	-	75
-	-	-	74

QTY	UNIT	DESCRIPTION	ITEM NO
-	-	-	84
-	-	-	83
-	-	-	82
-	-	-	81
-	-	-	80
-	-	-	79
-	-	-	78
-	-	-	77
-	-	-	76
-	-	-	75
-	-	-	74

QTY	UNIT	DESCRIPTION	ITEM NO
-	-	-	84
-	-	-	83
-	-	-	82
-	-	-	81
-	-	-	80
-	-	-	79
-	-	-	78
-	-	-	77
-	-	-	76
-	-	-	75
-	-	-	74

QTY	UNIT	DESCRIPTION	ITEM NO
-	-	-	84
-	-	-	83
-	-	-	82
-	-	-	81
-	-	-	80
-	-	-	79
-	-	-	78
-	-	-	77
-	-	-	76
-	-	-	75
-	-	-	74

QTY	UNIT	DESCRIPTION	ITEM NO
-	-	-	84
-	-	-	83
-	-	-	82
-	-	-	81
-	-	-	80
-	-	-	79
-	-	-	78
-	-	-	77
-	-	-	76
-	-	-	75
-	-	-	74

QTY	UNIT	DESCRIPTION	ITEM NO
-	-	-	84
-	-	-	83
-	-	-	82
-	-	-	81
-	-	-	80
-	-	-	79
-	-	-	78
-	-	-	77
-	-	-	76
-	-	-	75
-	-	-	74

QTY	UNIT	DESCRIPTION	ITEM NO
-	-	-	84
-	-	-	83
-	-	-	82
-	-	-	81
-	-	-	80
-	-	-	79
-	-	-	78
-	-	-	77
-	-	-	76
-	-	-	75
-	-	-	74

QTY	UNIT	DESCRIPTION	ITEM NO
-	-	-	84
-	-	-	83
-	-	-	82
-	-	-	81
-	-	-	80
-	-	-	79
-	-	-	78
-	-	-	77
-	-	-	76
-	-	-	75
-	-	-	74

QTY	UNIT	DESCRIPTION	ITEM NO
-	-	-	84
-	-	-	83
-	-	-	82
-	-	-	81
-	-	-	80
-	-	-	79
-	-	-	78
-	-	-	77
-	-	-	76
-	-	-	75
-	-	-	74

QTY	UNIT	DESCRIPTION	ITEM NO
-	-	-	84
-	-	-	83
-	-	-	82
-	-	-	81
-	-	-	80
-	-	-	79
-	-	-	78
-	-	-	77
-	-	-	76
-	-	-	75
-	-	-	74

QTY	UNIT	DESCRIPTION	ITEM NO
-	-	-	84
-	-	-	83
-	-	-	82
-	-	-	81
-	-	-	80
-	-	-	79
-	-	-	78
-	-	-	77
-	-	-	76
-	-	-	75
-	-	-	74

QTY	UNIT	DESCRIPTION	ITEM NO
-	-	-	84
-	-	-	83
-	-	-	82
-	-	-	81
-	-	-	80
-	-	-	79
-	-	-	78
-	-	-	77
-	-	-	76
-	-	-	75
-	-	-	74

QTY	UNIT	DESCRIPTION	ITEM NO
-	-	-	84
-	-	-	83
-	-	-	82
-	-	-	81
-	-	-	80
-	-	-	79
-	-	-	78
-	-	-	77
-	-	-	76
-	-	-	75
-	-	-	74

QTY	UNIT	DESCRIPTION	ITEM NO
-	-	-	84
-	-	-	83
-	-	-	82
-	-	-	81
-	-	-	80
-	-	-	79
-	-	-	78
-	-	-	77
-	-	-	76
-	-	-	75
-	-	-	74

QTY	UNIT	DESCRIPTION	ITEM NO
-	-	-	84
-	-	-	83
-	-	-	82
-	-	-	81
-	-	-	80
-	-	-	79
-	-	-	78
-	-	-	77
-	-	-	76
-	-	-	75
-	-	-	74

QTY	UNIT	DESCRIPTION	ITEM NO
-	-	-	84
-	-	-	83
-	-	-	82
-	-	-	81
-	-	-	80
-	-	-	79
-	-	-	78
-	-	-	77
-	-	-	76
-	-	-	75
-	-	-	74

QTY	UNIT	DESCRIPTION	ITEM NO
-	-	-	84</