

LOC	DIST	REV	DESCRIPTION	DATE	BY	APPV
C	REV PER ECO-07-017102			21SEP07	PY	BW

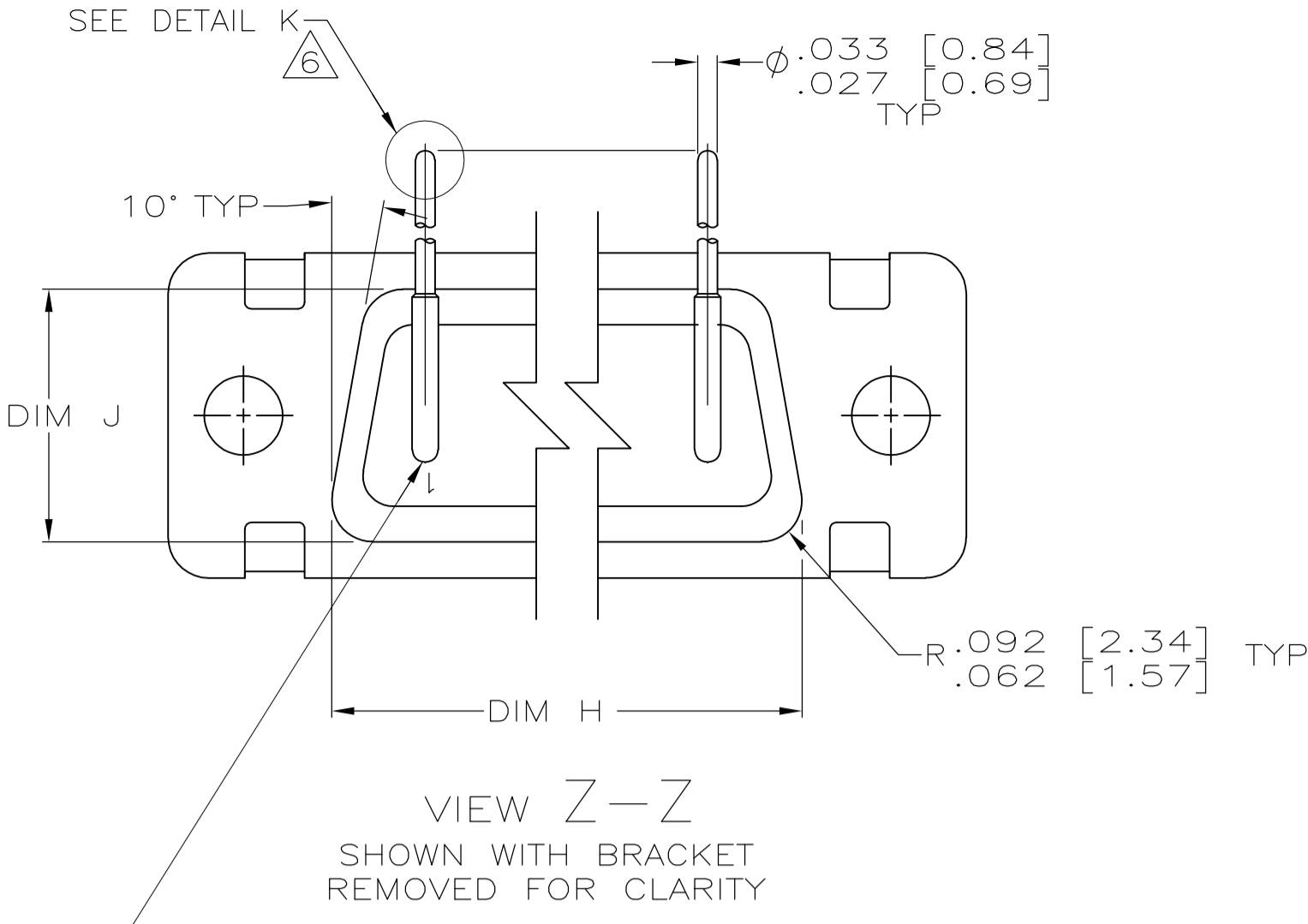

CONTACT (QTY = NO. OF POSN)
 MATL: BRASS PER ASTM-B-16, OR BERYLLIUM COPPER PER ASTM-B-194
 FINISH: GOLD PER MIL-G-45204, TYPE II, GRADE C, CLASS 1 IN CONTACT MATING AREA, .000010 [0.0003] MIN THK GOLD PER MIL-G-45204 OVER .000050 [0.0013] MIN THK NICKEL PER QQ-N-290 ON CONTACT BODY

- 1. SEE SHEET 2 FOR RECOMMENDED P.C. BOARD LAYOUT. TRUE POSITION TOLERANCE FOR P.C. BOARD LAYOUT IS .010 [0.25] AT MAX MATERIAL CONDITION. SUGGESTED BOARD THICKNESS IS .062 [1.57]
 - 2. THE CONNECTORS DESCRIBED IN THIS DOCUMENT MEET THE REQUIREMENTS OF MIL-C-24308 AND MATE WITH ANY RECEPTACLE CONNECTOR WITH SAME INSERT ARRANGEMENT.
 - 3. MARKED WITH .047 [1.19]-.062 [1.57] HIGH CHARACTERS. FAR SIDE REFERS TO THE WIDE SIDE OF THE KEYSTONE. NEAR SIDE REFERS TO THE NARROW SIDE OF THE KEYSTONE. IF THE REAR SHELL IS TOO SMALL FOR THE ENTIRE MILITARY PART NUMBER, MARKING SHALL BE LOCATED AS FOLLOWS:
 - A. "M24308" ON FRONT SHELL, FAR SIDE.
 - B. SLASH SHEET AND DASH NUMBER ON REAR SHELL, FAR SIDE.
 - C. "AMP" AND DATE CODE ON FRONT SHELL, NEAR SIDE.
 - D. AMP PART NUMBER ON REAR SHELL, NEAR SIDE.
- IF THE FRONT SHELL IS TOO SMALL FOR "AMP", AMP PART NUMBER AND DATE CODE, MARKING SHALL BE SPLIT AS FOLLOWS:
- A. AMP PART NUMBER ON REAR SHELL, NEAR SIDE.
 - B. "AMP" AND DATE CODE ON FRONT SHELL, NEAR SIDE.
 - C. MILITARY PART NUMBER ON REAR SHELL, FAR SIDE.

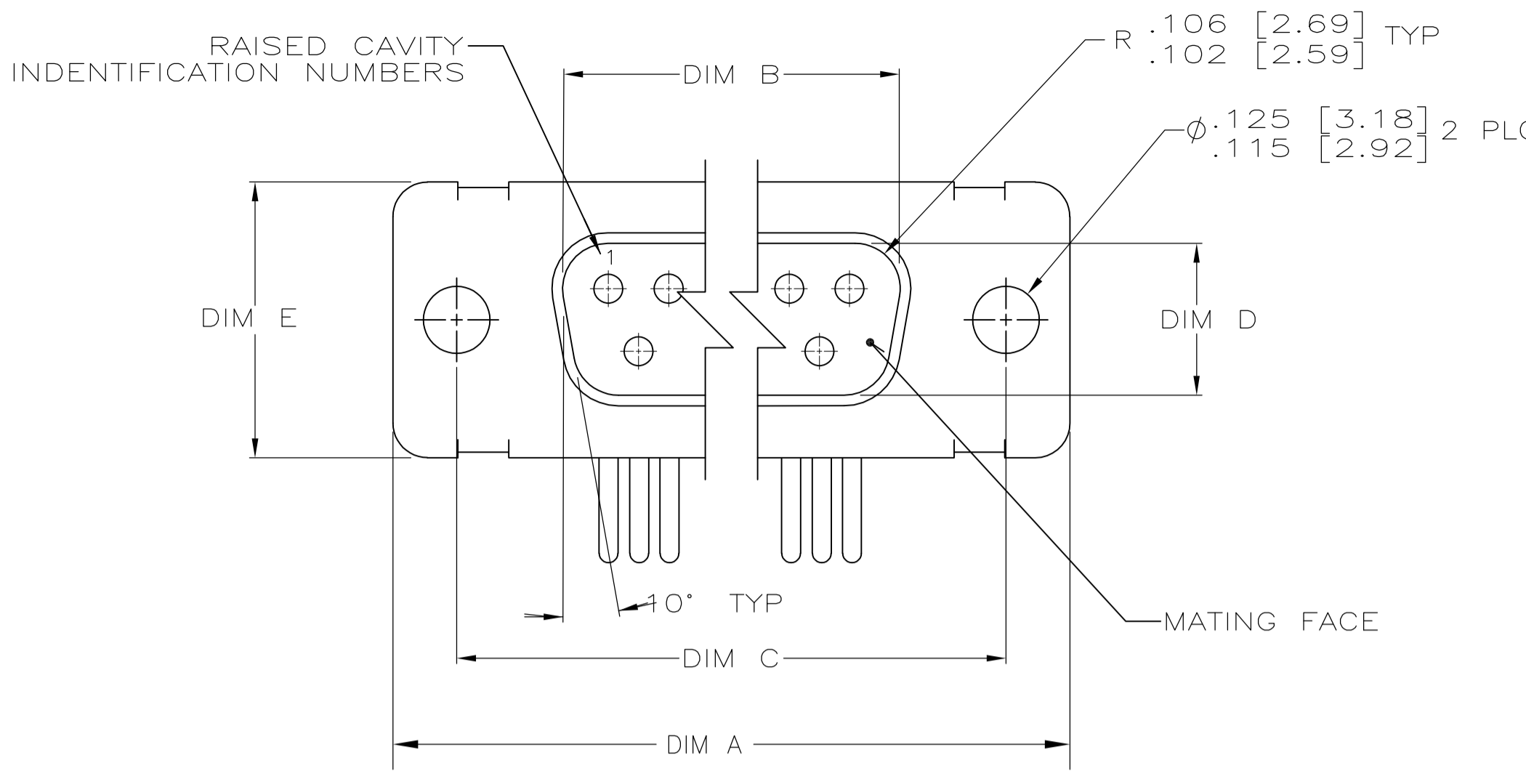
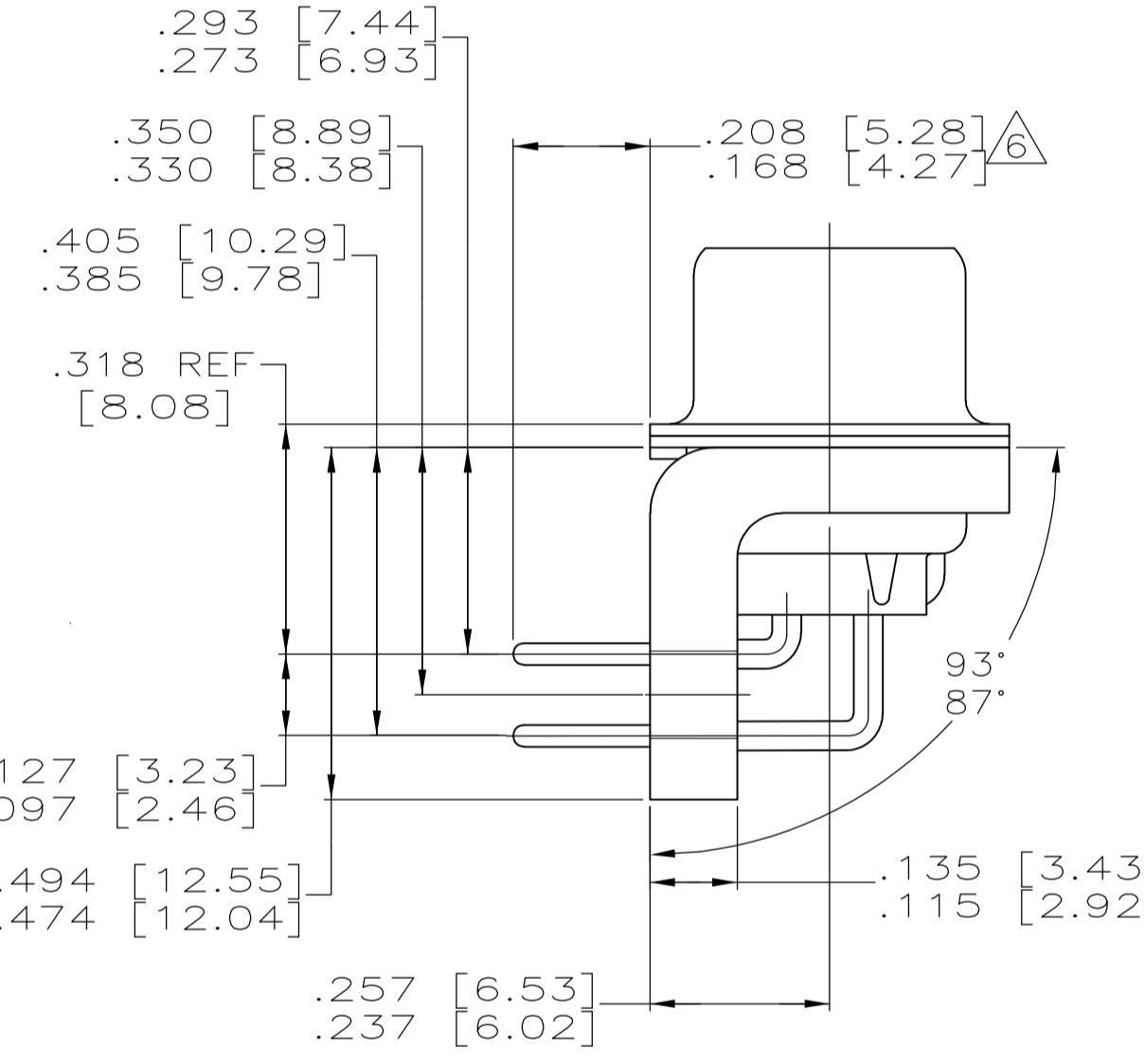
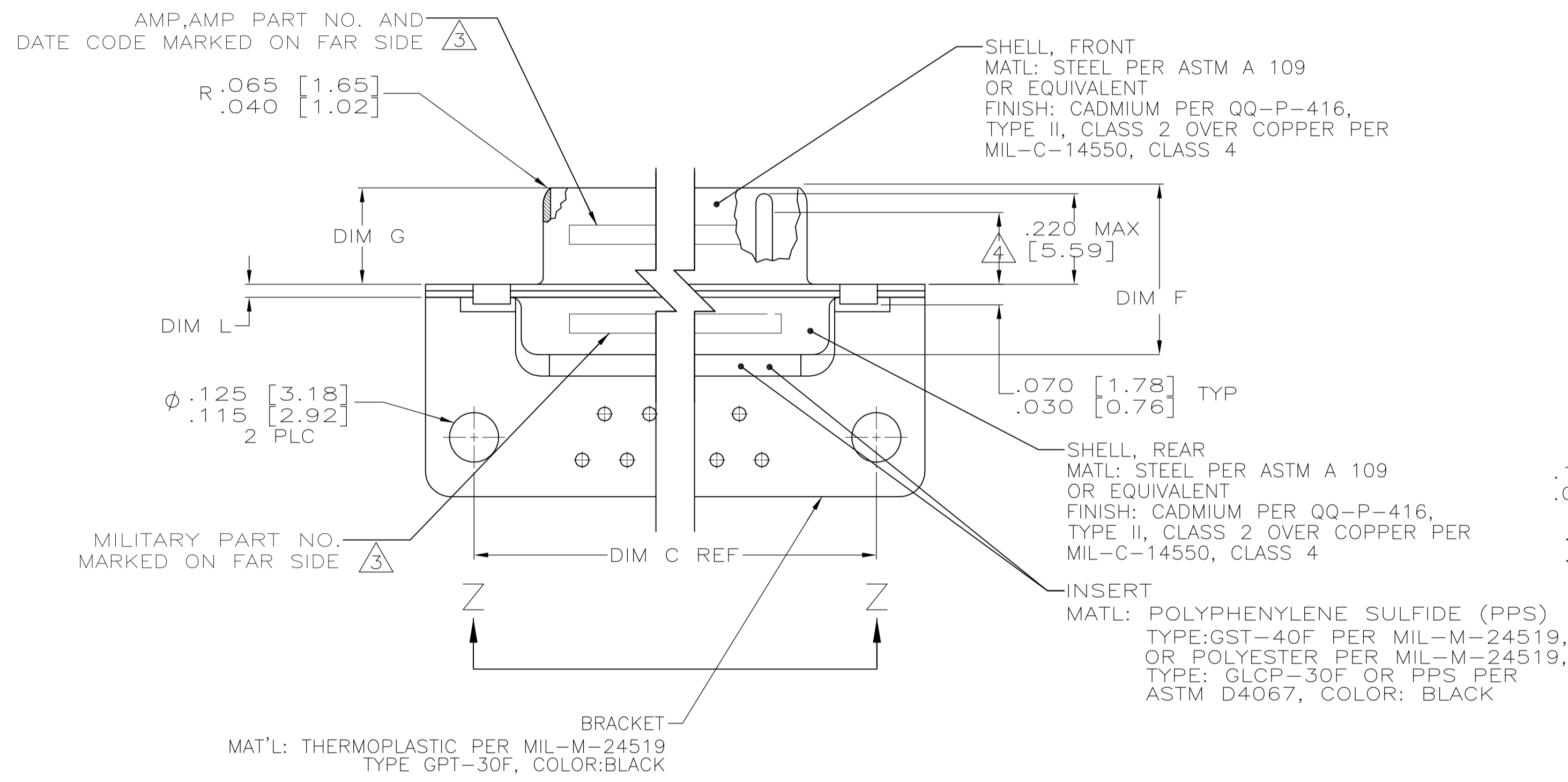

SHELL SIZES 1 THRU 4 CONTACT CONFIGURATION

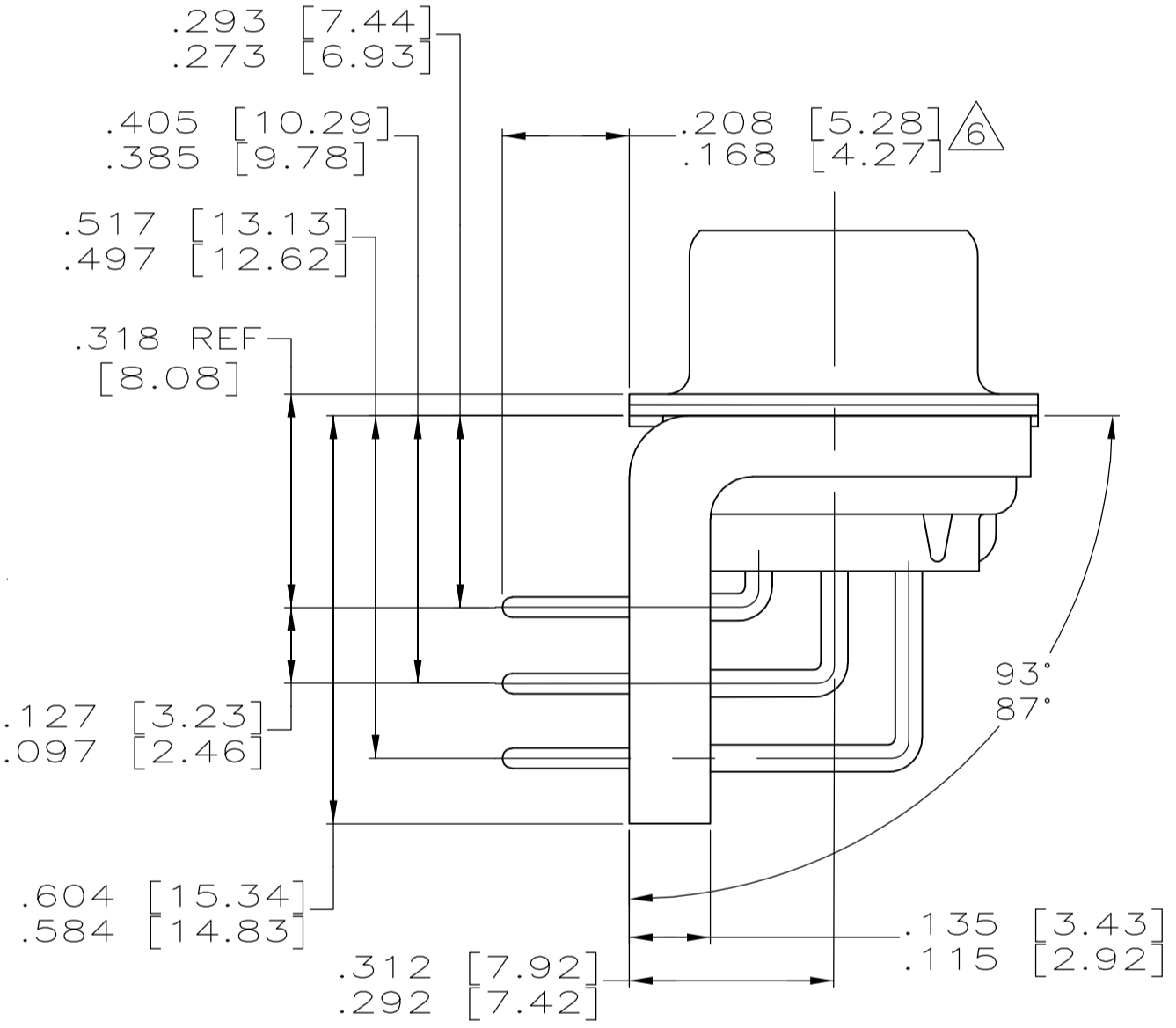

SHELL SIZE 5 CONTACT CONFIGURATION

.049 [1.24]	.544 [13.82]	2.188 [55.58]	.236 [5.99]	.436 [11.07]	.620 [15.75]	.446 [11.33]	2.411 [61.24]	2.084 [52.55]	2.650 [67.31]	MS18277-1	50	5	M24308/24-53F	1218444-5	1-1218444-0
.029 [0.74]	.524 [13.31]	2.168 [55.07]	.224 [5.69]	.416 [10.57]	.590 [14.99]	.436 [11.07]	2.401 [60.99]	2.074 [52.30]	2.620 [66.55]	MS18276-1	37	4	M24308/24-52F	1218444-4	1218444-9
.049 [1.24]	.432 [10.97]	2.282 [57.96]	.236 [5.99]	.436 [11.07]	.509 [12.93]	.334 [8.48]	2.505 [63.63]	2.187 [54.97]	2.744 [69.70]	MS18275-1	25	3	M24308/24-51F	1218444-3	1218444-8
.029 [0.74]	.412 [10.46]	2.262 [57.45]	.224 [5.69]	.416 [10.57]	.479 [12.17]	.324 [8.23]	2.495 [63.37]	2.177 [54.71]	2.714 [68.94]	MS18274-1	15	2	M24308/24-50F	1218444-2	1218444-7
.049 [1.24]	.432 [10.97]	1.635 [41.53]	.236 [5.99]	.436 [11.07]	.509 [12.93]	.334 [8.48]	1.857 [47.17]	1.539 [38.51]	2.103 [53.42]	MS18273-1	9	1	M24308/24-49F	1218444-1	1218444-6
.029 [0.74]	.412 [10.46]	1.615 [41.02]	.224 [5.69]	.416 [10.57]	.479 [12.17]	.324 [8.23]	1.847 [46.91]	1.529 [38.25]	2.073 [52.65]	MS18277-1	50	5	M24308/24-53F	1218444-5	1218444-5
.040 [1.02]	.432 [10.97]	2.282 [57.96]	.236 [5.99]	.436 [11.07]	.509 [12.93]	.334 [8.48]	2.505 [63.63]	2.187 [54.97]	2.744 [69.70]	MS18276-1	37	4	M24308/24-52F	1218444-4	1218444-4
.020 [0.51]	.412 [10.46]	2.262 [57.45]	.224 [5.69]	.416 [10.57]	.479 [12.17]	.324 [8.23]	2.495 [63.37]	2.177 [54.71]	2.714 [68.94]	MS18275-1	25	3	M24308/24-51F	1218444-3	1218444-3
.040 [1.02]	.432 [10.97]	1.635 [41.53]	.236 [5.99]	.436 [11.07]	.509 [12.93]	.334 [8.48]	1.857 [47.17]	1.539 [38.51]	2.103 [53.42]	MS18274-1	15	2	M24308/24-50F	1218444-2	1218444-2
.020 [0.51]	.412 [10.46]	1.615 [41.02]	.224 [5.69]	.416 [10.57]	.479 [12.17]	.324 [8.23]	1.847 [46.91]	1.529 [38.25]	2.073 [52.65]	MS18273-1	9	1	M24308/24-49F	1218444-1	1218444-1
.049 [1.24]	.544 [13.82]	2.188 [55.58]	.236 [5.99]	.436 [11.07]	.620 [15.75]	.446 [11.33]	2.411 [61.24]	2.084 [52.55]	2.650 [67.31]	MS18277-1	50	5	M24308/24-53F	1218444-5	1218444-5
.029 [0.74]	.524 [13.31]	2.168 [55.07]	.224 [5.69]	.416 [10.57]	.590 [14.99]	.436 [11.07]	2.401 [60.99]	2.074 [52.30]	2.620 [66.55]	MS18276-1	37	4	M24308/24-52F	1218444-4	1218444-4
.049 [1.24]	.432 [10.97]	2.282 [57.96]	.236 [5.99]	.436 [11.07]	.509 [12.93]	.334 [8.48]	2.505 [63.63]	2.187 [54.97]	2.744 [69.70]	MS18275-1	25	3	M24308/24-51F	1218444-3	1218444-3
.029 [0.74]	.412 [10.46]	2.262 [57.45]	.224 [5.69]	.416 [10.57]	.479 [12.17]	.324 [8.23]	2.495 [63.37]	2.177 [54.71]	2.714 [68.94]	MS18274-1	15	2	M24308/24-50F	1218444-2	1218444-2
.049 [1.24]	.432 [10.97]	1.635 [41.53]	.236 [5.99]	.436 [11.07]	.509 [12.93]	.334 [8.48]	1.857 [47.17]	1.539 [38.51]	2.103 [53.42]	MS18273-1	9	1	M24308/24-49F	1218444-1	1218444-1
.029 [0.74]	.412 [10.46]	1.615 [41.02]	.224 [5.69]	.416 [10.57]	.479 [12.17]	.324 [8.23]	1.847 [46.91]	1.529 [38.25]	2.073 [52.65]	MS18277-1	50	5	M24308/24-53F	1218444-5	1218444-5
.049 [1.24]	.432 [10.97]	2.282 [57.96]	.236 [5.99]	.436 [11.07]	.509 [12.93]	.334 [8.48]	2.505 [63.63]	2.187 [54.97]	2.744 [69.70]	MS18276-1	37	4	M24308/24-52F	1218444-4	1218444-4
.029 [0.74]	.412 [10.46]	2.262 [57.45]	.224 [5.69]	.416 [10.57]	.479 [12.17]	.324 [8.23]	2.495 [63.37]	2.177 [54.71]	2.714 [68.94]	MS18275-1	25	3	M24308/24-51F	1218444-3	1218444-3
.049 [1.24]	.432 [10.97]	1.635 [41.53]	.236 [5.99]	.436 [11.07]	.509 [12.93]	.334 [8.48]	1.857 [47.17]	1.539 [38.51]	2.103 [53.42]	MS18274-1	15	2	M24308/24-50F	1218444-2	1218444-2
.029 [0.74]	.412 [10.46]	1.615 [41.02]	.224 [5.69]	.416 [10.57]	.479 [12.17]	.324 [8.23]	1.847 [46.91]	1.529 [38.25]	2.073 [52.65]	MS18273-1	9	1	M24308/24-49F	1218444-1	1218444-1

DIM L	DIM J	DIM H	DIM G	DIM F	DIM E	DIM D	DIM C	DIM B	DIM A	INSERT ARRANGEMENT	NO OF POS	SHELL SIZE	MILITARY P/N ON CONNECTOR	AMP P/N MARKED ON CONNECTOR	AMP PART NO.

DETAIL K
 SCALE 8:1
 FOR 1218444-6 THRU -10 ONLY

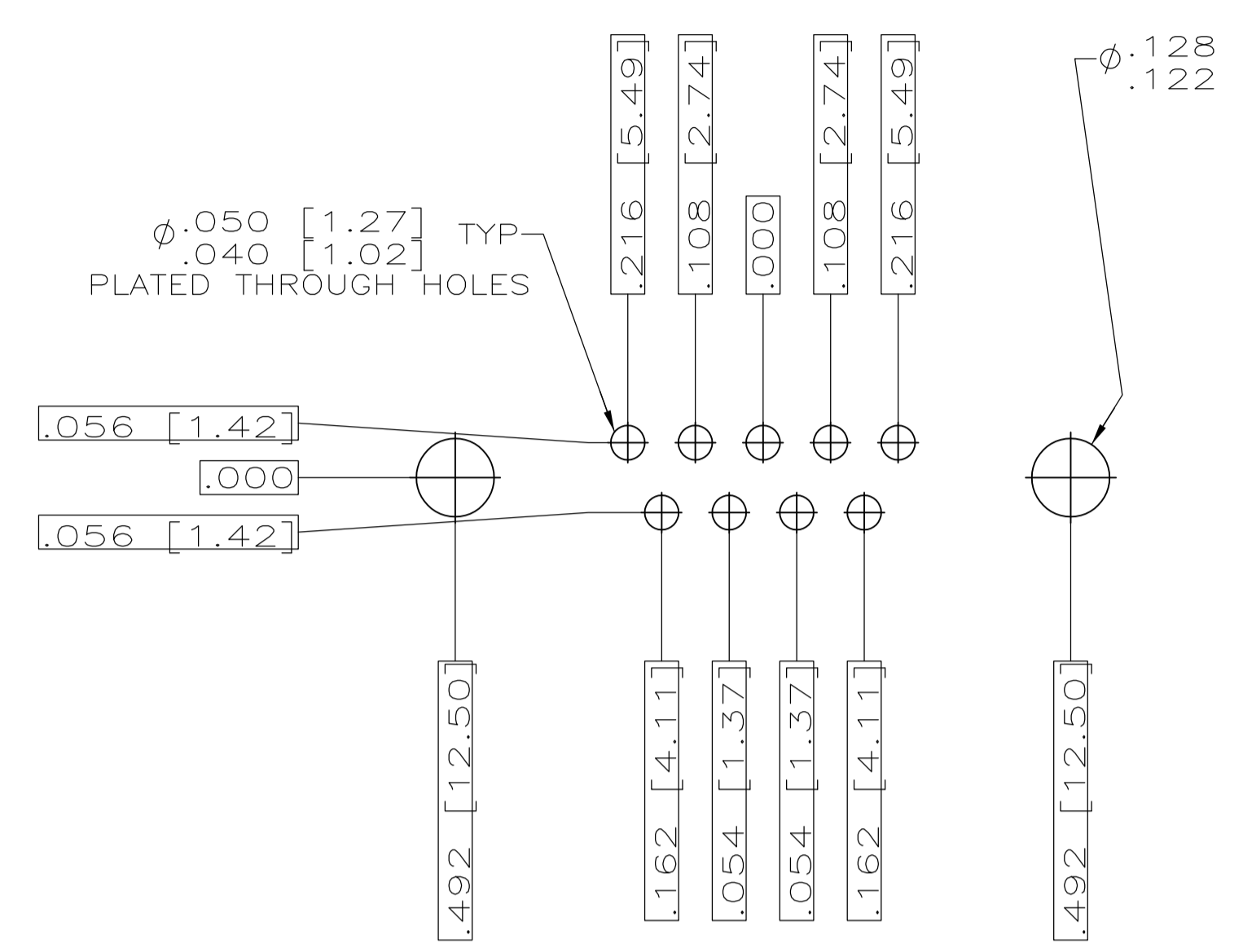

RECOMMENDED P.C. BOARD LAYOUT
SHELL SIZE 1 (9 POSITION) ⚠

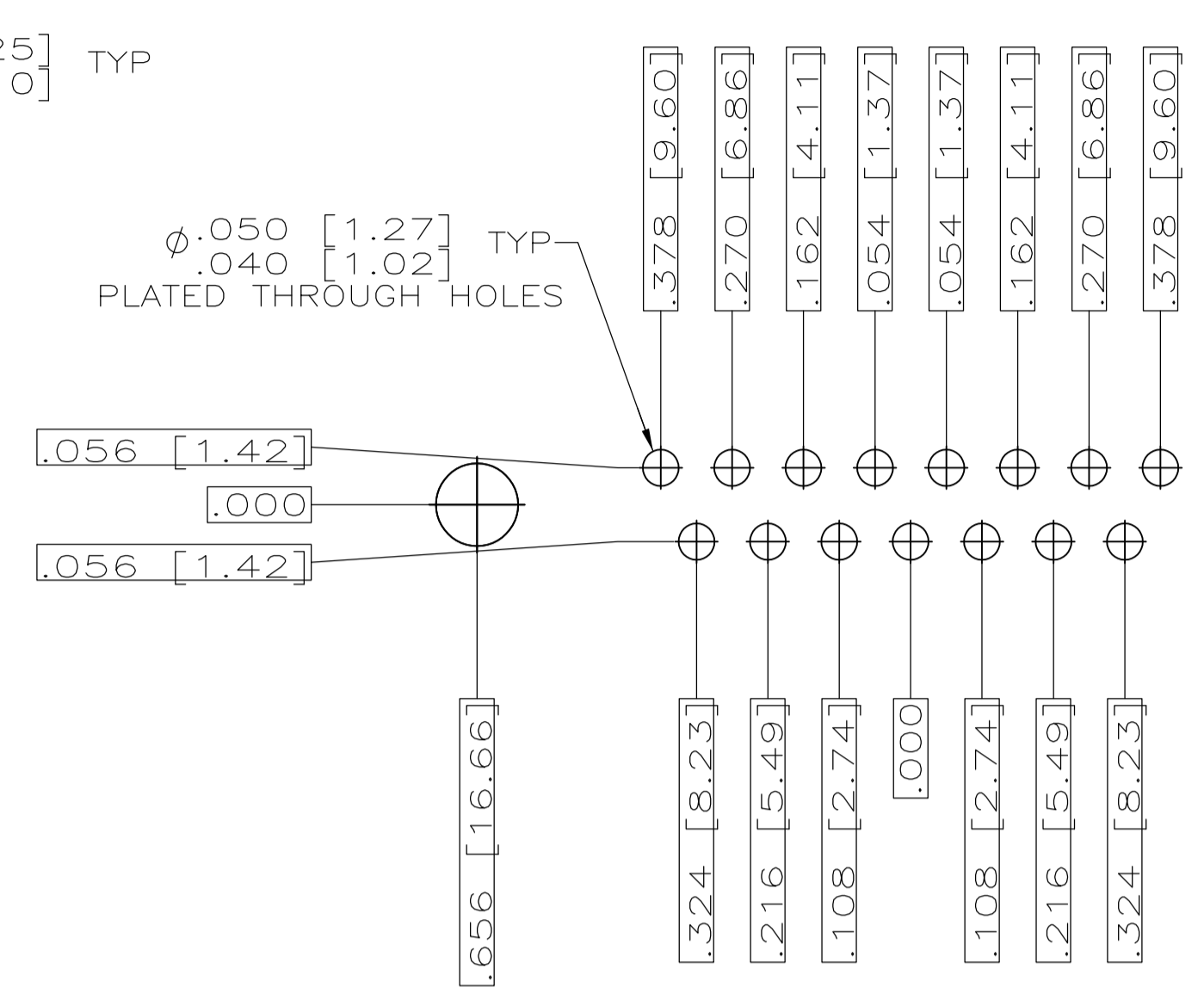

RECOMMENDED P.C. BOARD LAYOUT
SHELL SIZE 2 (15 POSITION) ⚠

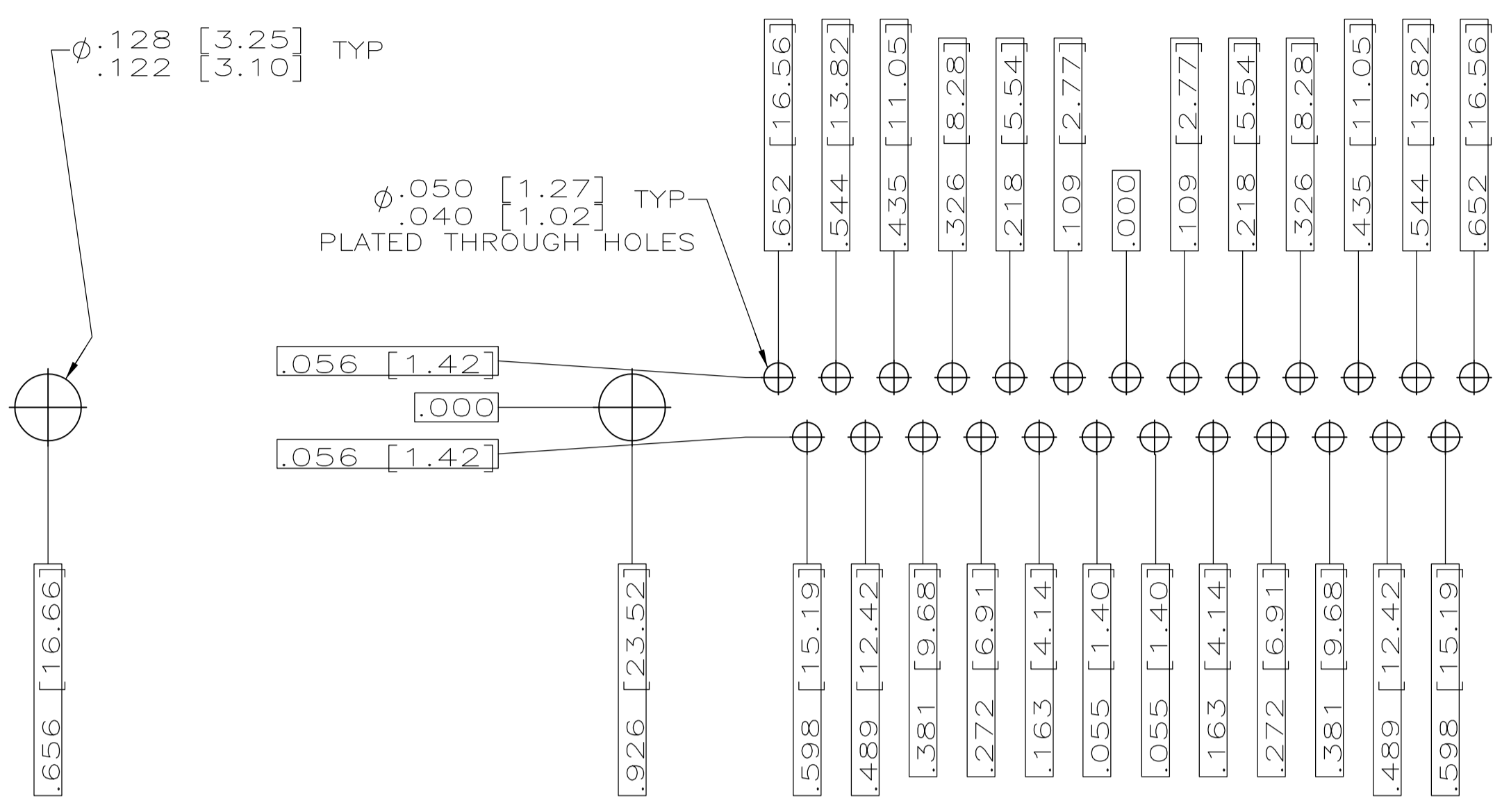

RECOMMENDED P.C. BOARD LAYOUT
SHELL SIZE 3 (25 POSITION) ⚠

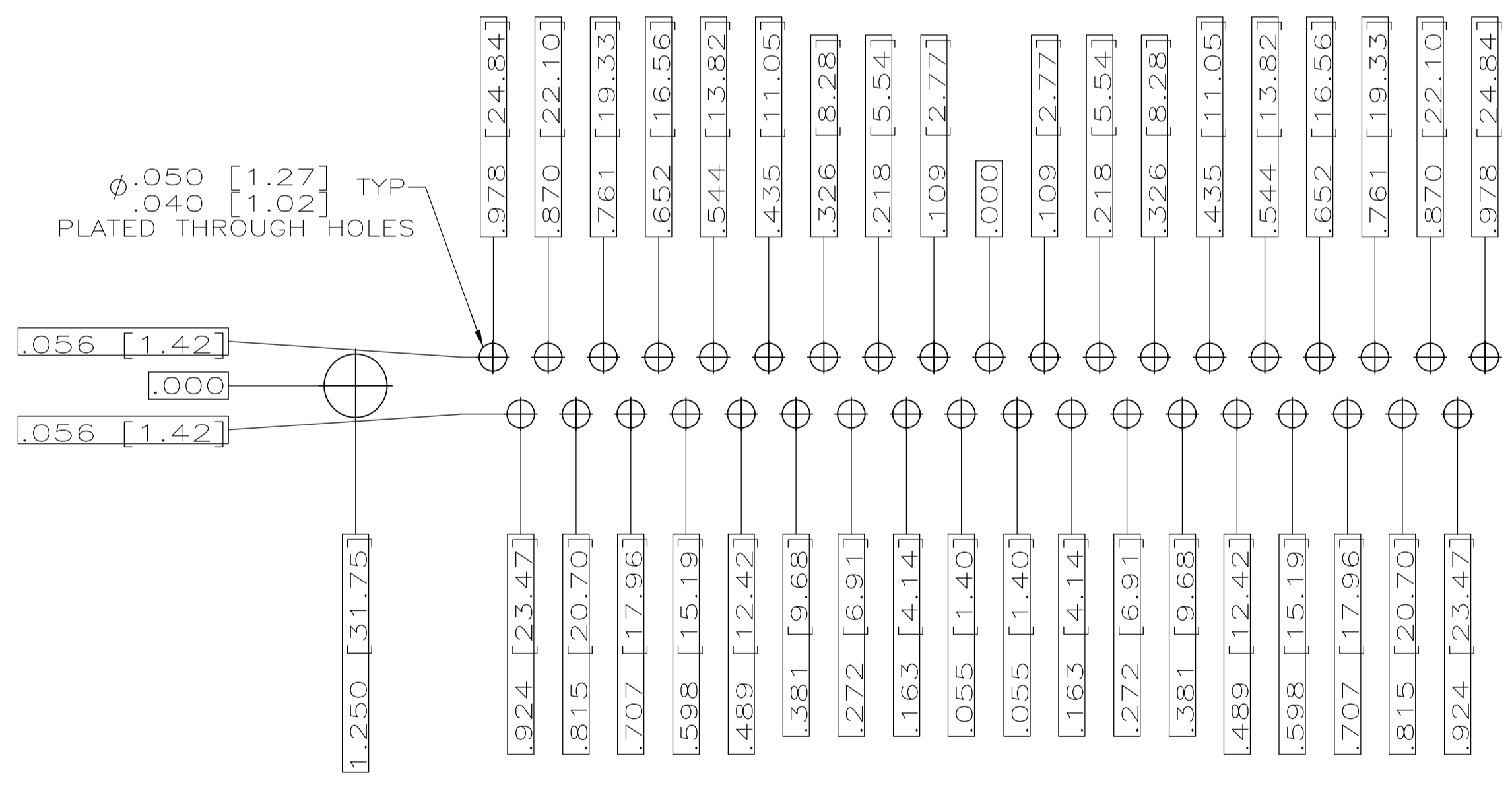

RECOMMENDED P.C. BOARD LAYOUT
SHELL SIZE 4 (37 POSITION) ⚠

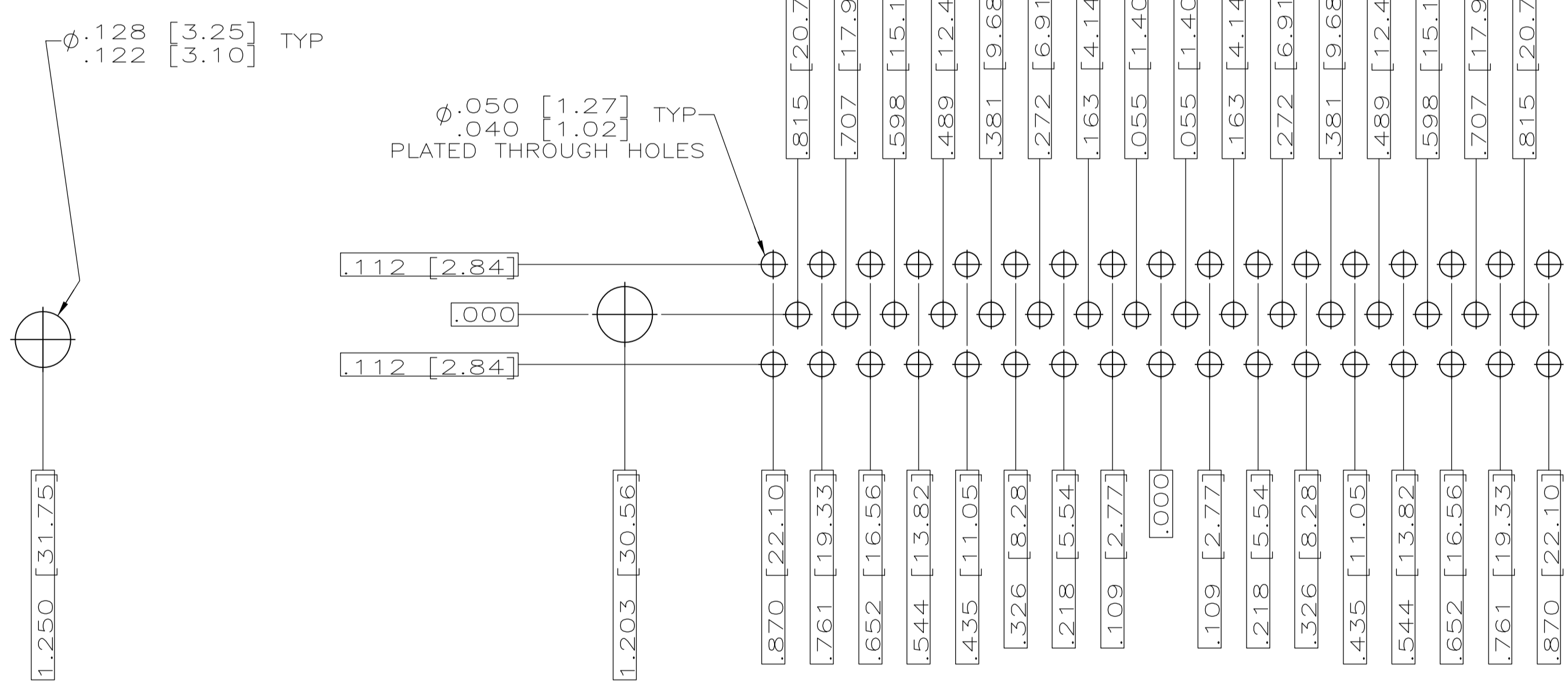

RECOMMENDED P.C. BOARD LAYOUT
SHELL SIZE 5 (50 POSITION) ⚠

THIS DRAWING IS A CONTROLLED DOCUMENT.		DIN	C.C.THOMAS	12-6-99	Tyco Electronics Corporation Harrisburg, PA 17105-3608
DIMENSIONS: INCHES		CHK	CHAD BAKER	12-15-99	
TOLERANCES UNLESS OTHERWISE SPECIFIED:		APVD	CHAD BAKER	12-15-99	NAME PLUG ASSY,AMPLIMITE RIGHT ANGLE,SERIES 109,SIZE 1 THRU 5
0 PL ± .005		PRODUCT SPEC			
1 PL ± .005		APPLICATION SPEC			SIZE
2 PL ± .005		FINISH			CAGE CODE
3 PL ± .005		SEE CALLOUTS			DRAWING NO
4 PL ± .005					RESTRICTED TO
5 PL ± .005					WEIGHT
MATERIAL					A1
SEE CALLOUTS					00779
					1218444
					CUSTOMER DRAWING
					SCALE 4:1
					SHEET 2 OF 2
					REV C