

LOC	DIST	REVISIONS			
P	LTR	DESCRIPTION	DATE	DNW	APVD
AA	22	A	REV PER ECOS11-0201-04	22JUN2005	GA SF

- MATERIAL:  
HOUSING  
 PBT POLYESTER, BLACK, UL 94V-0.  
TERMINALS  
 0.33 THICK PHOSPHOR BRONZE PLATED WITH 1.27μm MINIMUM THICK HARD GOLD IN LOCALIZED AREA AND 2μm MINIMUM THICK MATTE TIN IN ACTION PIN COMPLIANT PIN TERMINAL AREA OVER 1.27μm MINIMUM THICK NICKEL UNDERPLATE.  
SHIELD  
 0.25 THICK COPPER ALLOY PLATED WITH 2.03μm MINIMUM BRIGHT TIN OVER 1.27μm MINIMUM NICKEL.
  - JACK CAVITY CONFORMS TO FCC RULES AND REGULATIONS, PART 68 SUBPART F.
  - ALL DIMENSIONS ARE NOMINAL UNLESS OTHERWISE SPECIFIED.
- △4 DRILLED HOLE DIA = 1.02±.025.  
 COPPER THICKNESS = 0.025-0.075.  
 TIN THICKNESS = 0.008 MIN.
- △5 DATUMS AND BASIC DIMENSIONS ESTABLISHED BY CUSTOMER.
- △6 DATE CODE LOCATED ON REAR OF PART APPROXIMATELY AS SHOWN.
- △7 CONTACTS ARE NOT INTENDED TO BE ALIGNED WITH EACH OTHER.

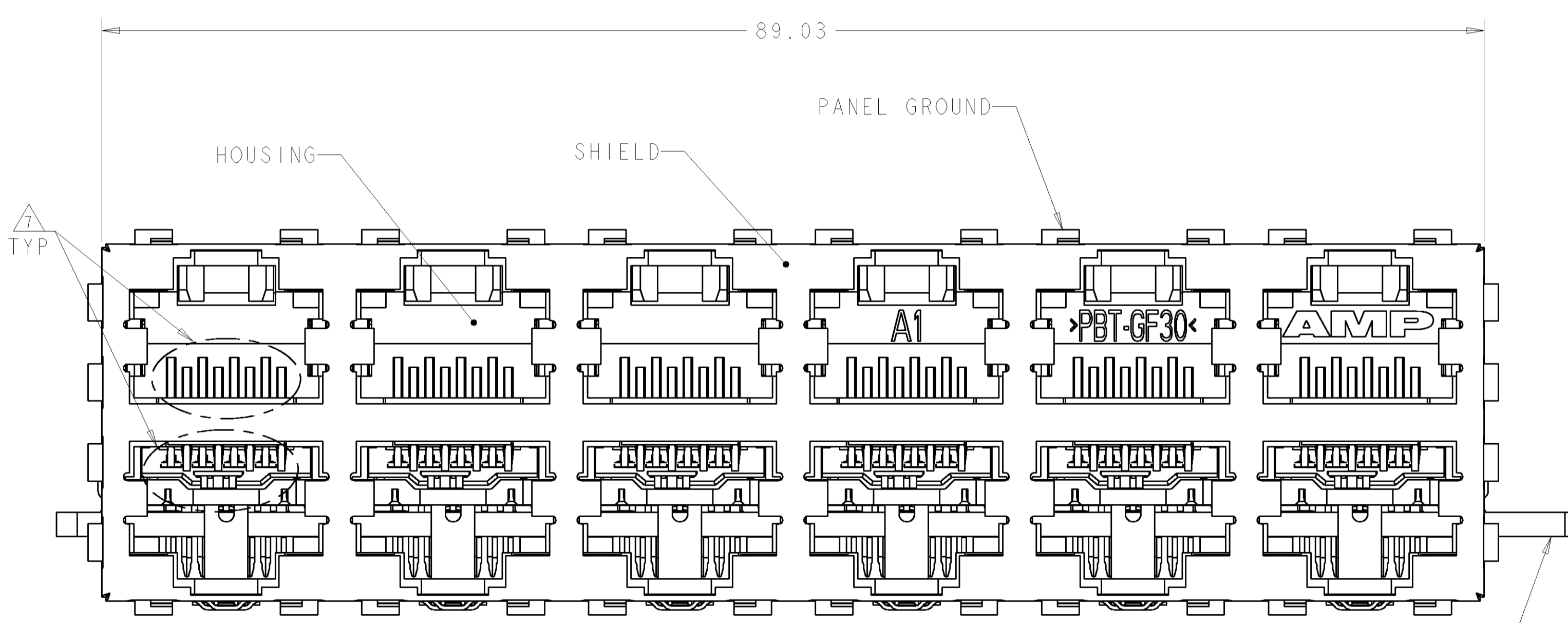

P/N 6368034-2 SHOWN

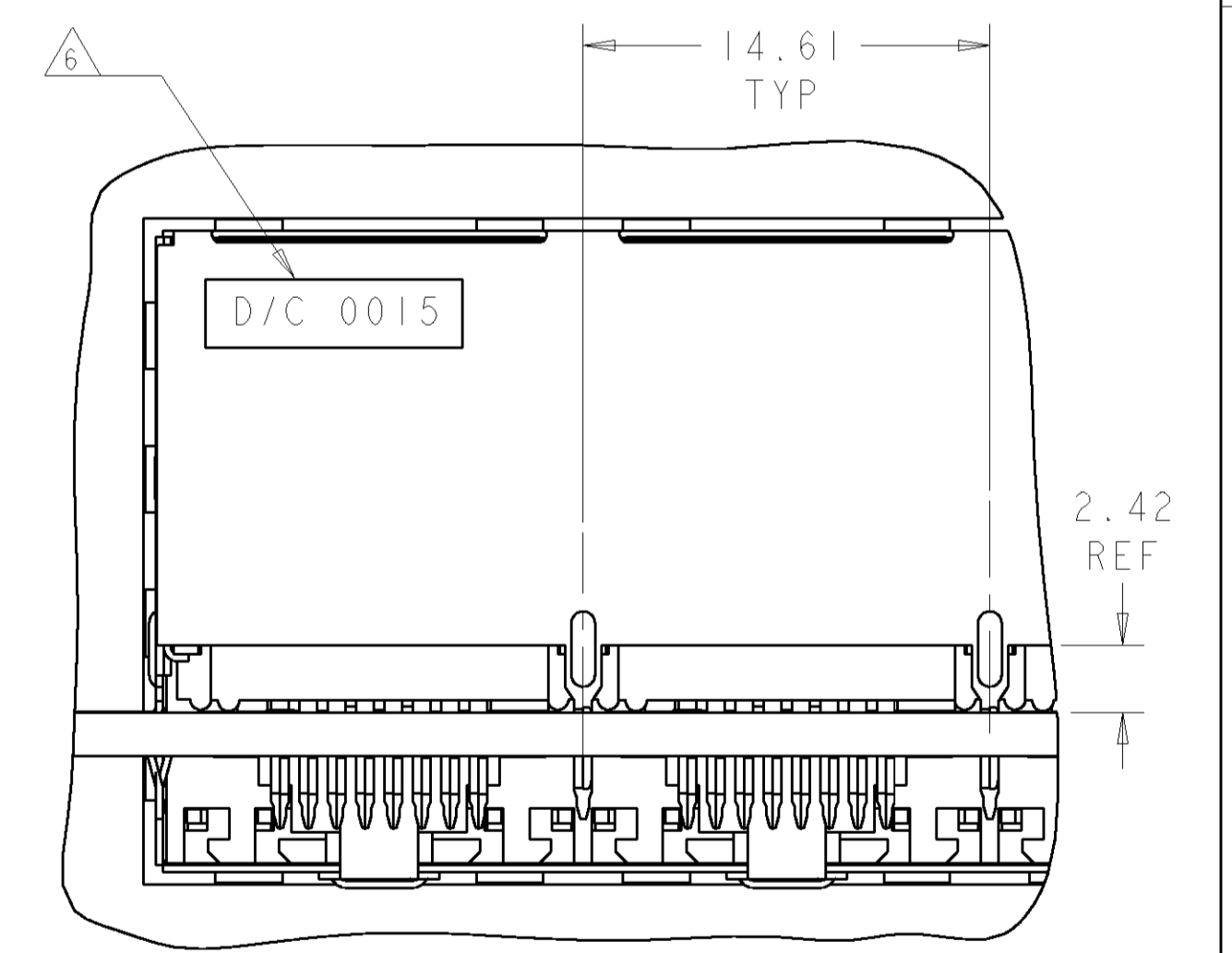
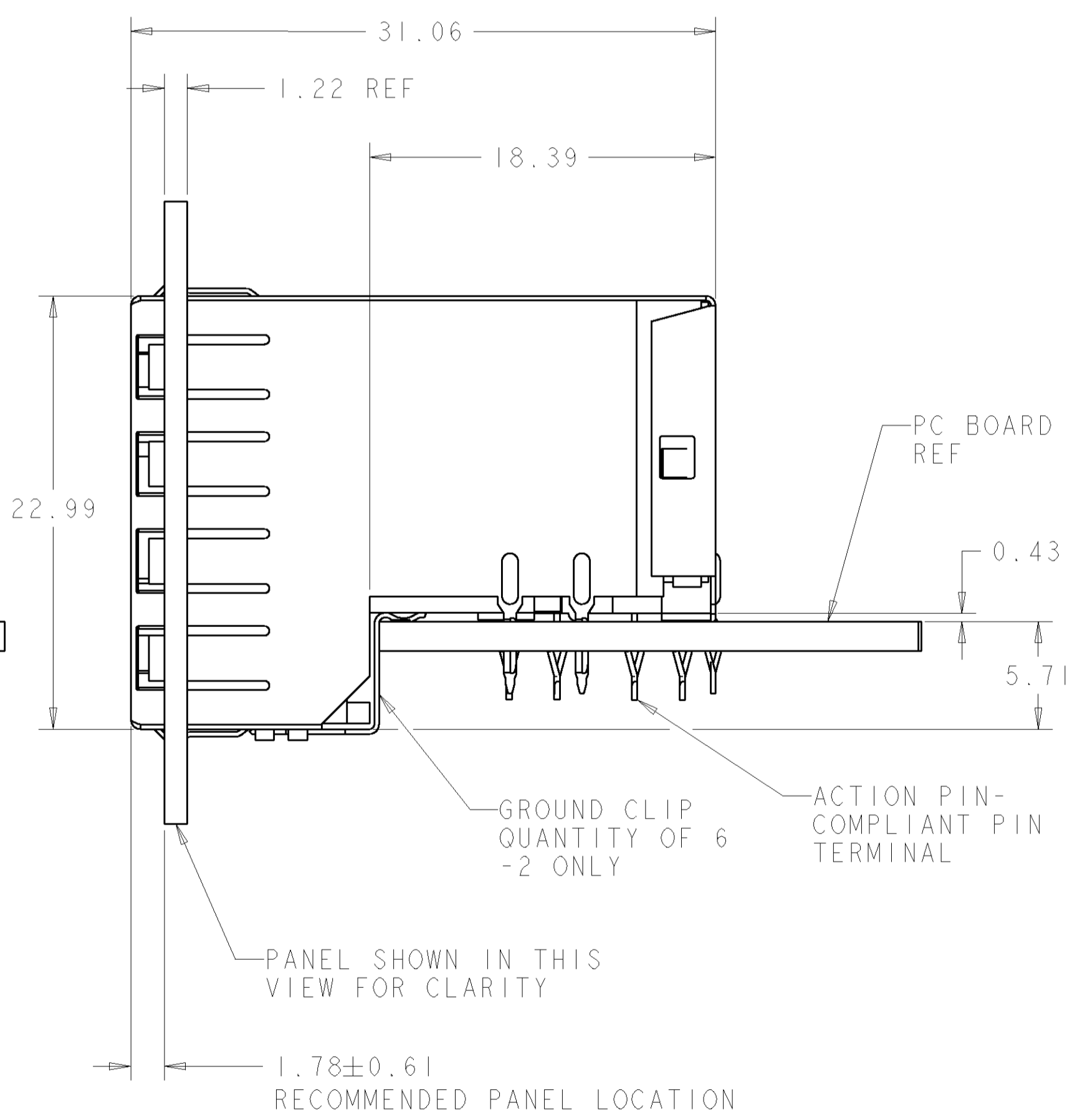

PARTIAL BACK VIEW

DESCRIPTION	PART NUMBER
WITH GROUND CLIP	6368034-2
WITHOUT GROUND CLIP	6368034-1

DIMENSIONS: mm 		TOLERANCES UNLESS OTHERWISE SPECIFIED: 0 PLC ± 1 PLC ±0.13 2 PLC ±0.13 3 PLC ± 4 PLC ± ANGLES ± FINISH ±		DWN G. ATTADIA 22JUN2005 ENR J. WESTMAN 22JUN2005 APVD S. FLICKINGER 22JUN2005 PRODUCT SPEC 108-1854 APPLICATION SPEC 114-2160 WEIGHT CUSTOMER DRAWING		Tyco Electronics Harrisburg, PA 17105-3608 NAME STACKED MODULAR JACK ASSEMBLY, 2X6 OFFSET, 8 POSN, RJ45 SHIELDED PANEL GROUND, NO LEDS, CAT 5 SIZE CAGE CODE DRAWING NO RESTRICTED TO A 00779 C-6368034 SCALE 4:1 SHEET 1 OF 2 REV A	
-----------------------	--	---	--	--	--	---	--

LOC	DIST	REVISIONS			
P	LTR	DESCRIPTION	DATE	DRN	APVD
AA	22	SEE SHEET 1	-	-	-

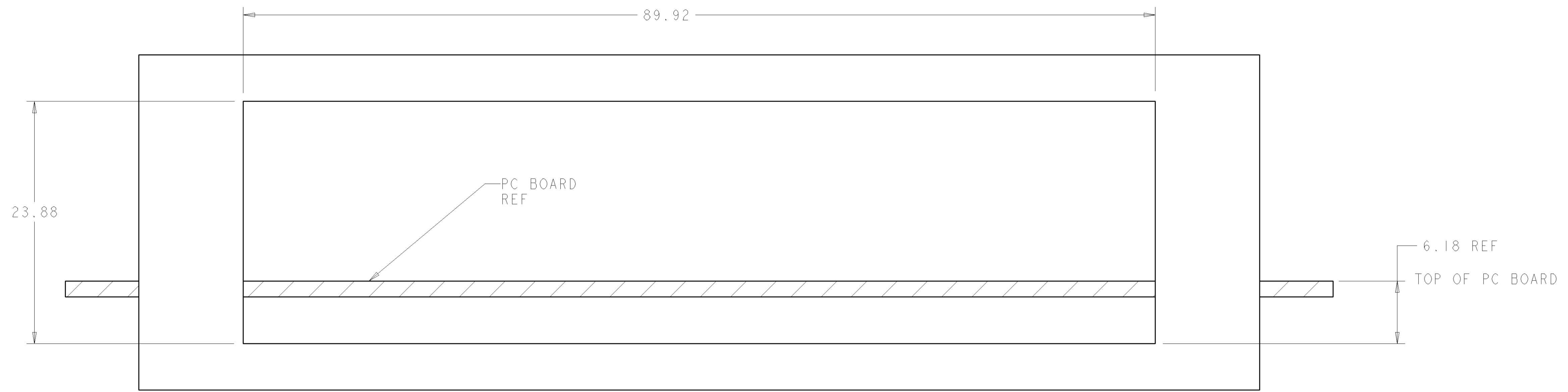

RECOMMENDED PANEL CUT-OUT

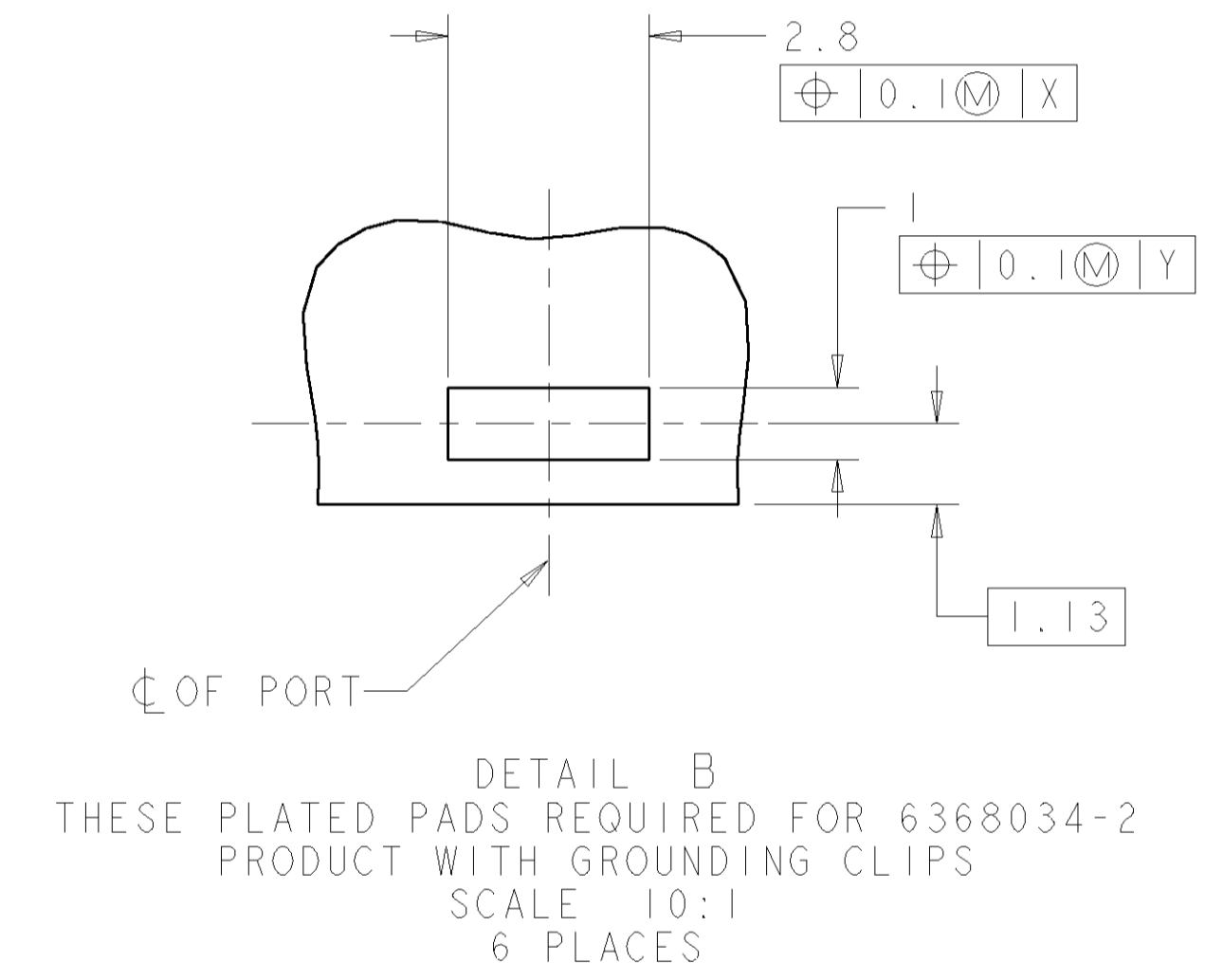
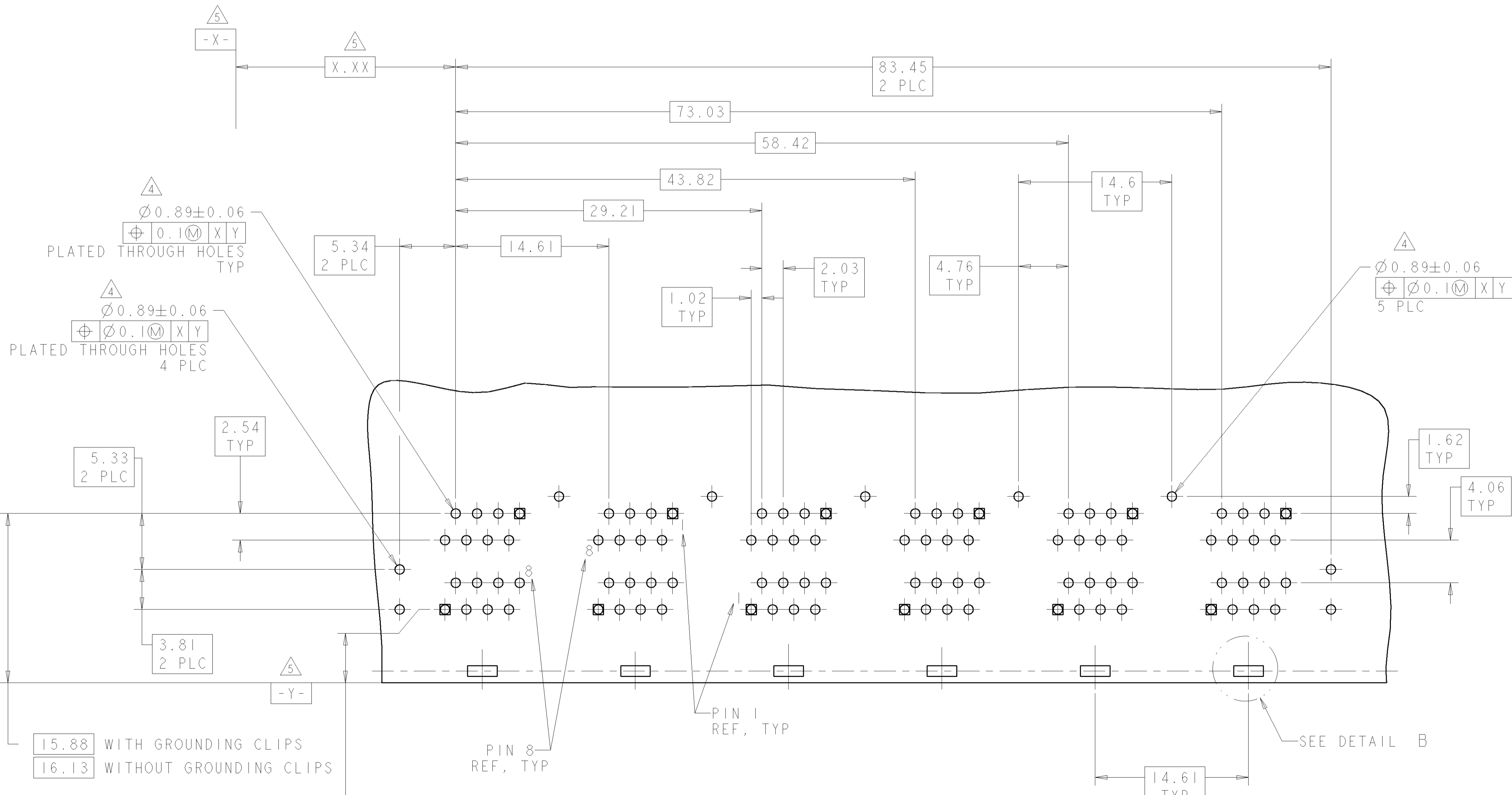

PARTS WITH GROUNDING CLIPS = 6.73  
 PARTS WITHOUT GROUNDING CLIPS = 6.99

PC BOARD LAYOUT  
 (COMPONENT SIDE)

<small>THIS DRAWING IS UNPUBLISHED. RELEASED FOR PUBLICATION BY TYCO ELECTRONICS CORPORATION. ALL RIGHTS RESERVED.</small>		DWN: 22 JUN 2005 LG: ATTAD1A - 00045 ENR: J. WESTMAN APVD: S. FLICKINGER	<b>tyco</b> Electronics Tyco Electronics Harrisburg, PA 17105-3608
DIMENSIONS: mm 	TOLERANCES UNLESS OTHERWISE SPECIFIED: 0 PLC ± 1 PLC ±0.13 2 PLC ±0.13 3 PLC ± 4 PLC ± ANGLES ±1	NAME: STACKED MODULAR JACK ASSEMBLY, 2X6 OFFSET, 8 POSN, RJ45 SHIELDED PANEL GROUND, NO LEDS, CAT 5 PRODUCT SPEC: APPLICATION SPEC: SIZE: A1 CAGE CODE: 00779 DRAWING NO: 6368034	RESTRICTED TO: CUSTOMER DRAWING SCALE: 4:1 SHEET: 2 OF 2 REV: A