

SmartLEWIS™ MCU

Smart Low Energy Wireless Systems with a Microcontroller Unit

PMA51xx

RF Transmitter ASK/FSK 315/434/868/915 MHz,
Embedded 8051 Microcontroller,
10-bit ADC,
125 kHz ASK LF Receiver

PMA5110 Version 1.0

PMA5105 Version 1.0

Data Sheet

Revision 2.1, 2010-06-02

Edition 2010-06-02

**Published by
Infineon Technologies AG
81726 Munich, Germany**

**© 2010 Infineon Technologies AG
All Rights Reserved.**

Legal Disclaimer

The information given in this document shall in no event be regarded as a guarantee of conditions or characteristics. With respect to any examples or hints given herein, any typical values stated herein and/or any information regarding the application of the device, Infineon Technologies hereby disclaims any and all warranties and liabilities of any kind, including without limitation, warranties of non-infringement of intellectual property rights of any third party.

Information

For further information on technology, delivery terms and conditions and prices, please contact the nearest Infineon Technologies Office (www.infineon.com).

Warnings

Due to technical requirements, components may contain dangerous substances. For information on the types in question, please contact the nearest Infineon Technologies Office.

Infineon Technologies components may be used in life-support devices or systems only with the express written approval of Infineon Technologies, if a failure of such components can reasonably be expected to cause the failure of that life-support device or system or to affect the safety or effectiveness of that device or system. Life support devices or systems are intended to be implanted in the human body or to support and/or maintain and sustain and/or protect human life. If they fail, it is reasonable to assume that the health of the user or other persons may be endangered.

**PMA51xx RF Transmitter ASK/FSK 315/434/868/915 MHz,
 Embedded 8051 Microcontroller,
 10-bit ADC,
 125 kHz ASK LF Receiver**

Revision History: 2010-06-02, Revision 2.1

Previous Revision: 2.0

Page	Subjects (major changes since last revision)
101, 86	Added note to use Library function LFSensitivityCalibration() for LF Carrier Detector Threshold Level Selection.

Trademarks of Infineon Technologies AG

A-GOLD™, BlueMoon™, COMNEON™, CONVERGATE™, COSIC™, C166™, CROSSAVE™, CanPAK™, CIPOS™, CoolMOS™, CoolSET™, CONVERPATH™, CORECONTROL™, DAVE™, DUALFALC™, DUSLIC™, EasyPIM™, EconoBRIDGE™, EconoDUAL™, EconoPACK™, EconoPIM™, E-GOLD™, EiceDRIVER™, EUPEC™, ELIC™, EPIC™, FALC™, FCOS™, FLEXISLIC™, GEMINAX™, GOLDMOS™, HITFET™, HybridPACK™, INCA™, ISAC™, ISOFACE™, IsoPACK™, IWORX™, M-GOLD™, MIPAQ™, ModSTACK™, MUSLIC™, my-d™, NovalithIC™, OCTALFALC™, OCTAT™, OmniTune™, OmniVia™, OptiMOS™, OPTIVERSE™, ORIGA™, PROFET™, PRO-SIL™, PrimePACK™, QUADFALC™, RASIC™, ReverSave™, SatRIC™, SCEPTRE™, SCOUT™, S-GOLD™, SensoNor™, SEROCCO™, SICOFI™, SIEGET™, SINDRION™, SLIC™, SMARTi™, SmartLEWIS™, SMINT™, SOCRATES™, TEMPFET™, thinQ!™, TrueENTRY™, TriCore™, TRENCHSTOP™, VINAX™, VINETIC™, VIONTIC™, WildPass™, X-GOLD™, XMM™, X-PMU™, XPOSYS™, XWAY™.

Other Trademarks

AMBA™, ARM™, MULTI-ICE™, PRIMECELL™, REALVIEW™, THUMB™ of ARM Limited, UK. AUTOSAR™ is licensed by AUTOSAR development partnership. Bluetooth™ of Bluetooth SIG Inc. CAT-iq™ of DECT Forum. COLOSSUS™, FirstGPS™ of Trimble Navigation Ltd. EMV™ of EMVCo, LLC (Visa Holdings Inc.). EPCOS™ of Epcos AG. FLEXGO™ of Microsoft Corporation. FlexRay™ is licensed by FlexRay Consortium. HYPERTERMINAL™ of Hilgraeve Incorporated. IEC™ of Commission Electrotechnique Internationale. IrDA™ of Infrared Data Association Corporation. ISO™ of INTERNATIONAL ORGANIZATION FOR STANDARDIZATION. MATLAB™ of MathWorks, Inc. MAXIM™ of Maxim Integrated Products, Inc. MICROTEC™, NUCLEUS™ of Mentor Graphics Corporation. Mifare™ of NXP. MIPI™ of MIPI Alliance, Inc. MIPS™ of MIPS Technologies, Inc., USA. muRata™ of MURATA MANUFACTURING CO. OmniVision™ of OmniVision Technologies, Inc. Openwave™ Openwave Systems Inc. RED HAT™ Red Hat, Inc. RFMD™ RF Micro Devices, Inc. SIRIUS™ of Sirius Sattelite Radio Inc. SOLARIS™ of Sun Microsystems, Inc. SPANSION™ of Spansion LLC Ltd. Symbian™ of Symbian Software Limited. TAIYO YUDEN™ of Taiyo Yuden Co. TEAKLITE™ of CEVA, Inc. TEKTRONIX™ of Tektronix Inc. TOKO™ of TOKO KABUSHIKI KAISHA TA. UNIX™ of X/Open Company Limited. VERILOG™, PALLADIUM™ of Cadence Design Systems, Inc. VLYNQ™ of Texas Instruments Incorporated. VXWORKS™, WIND RIVER™ of WIND RIVER SYSTEMS, INC. ZETEX™ of Diodes Zetex Limited.

Last Trademarks Update 2009-10-19

Table of Contents

	Table of Contents	4
	List of Figures	9
	List of Tables	11
1	Product Description	13
1.1	Overview	13
1.2	PMAx1xx Product Family	14
1.3	Applications	14
1.4	Key Features	14
1.5	Pin Diagram	16
1.6	Pin Description	17
1.7	Functional Block Diagram	28
2	Functional Description	29
2.1	Operating Modes and States	29
2.1.1	Operating Mode Selection	29
2.1.2	State Description	32
2.1.2.1	INIT state	32
2.1.2.2	RUN state	32
2.1.2.3	IDLE state	32
2.1.2.4	POWER DOWN state (PDWN)	33
2.1.2.5	State Transitions	33
2.1.2.6	Status of PMA5110 Blocks in Different States	34
2.2	System Controller	35
2.2.1	Wake-up Logic	35
2.2.1.1	Register Description	37
2.2.2	Interval Timer	42
2.2.3	Register Description	43
2.3	System Configuration Registers	45
2.3.1	Register Description	45
2.4	Fault Protection	50
2.4.1	Watchdog Timer	50
2.4.2	Vmin Detector	50
2.4.2.1	Register Description	50
2.4.3	Brownout Detector	51
2.4.4	FLASH Memory Checksum	51
2.4.5	ADC Measurement Overflow and Underflow	51
2.5	Clock Controller	52
2.5.1	Internal Clock Divider	52
2.5.2	2 kHz RC LP Oscillator (Low Power)	52
2.5.3	12 MHz RC HF Oscillator (High Frequency)	53
2.5.4	Crystal Oscillator	53
2.5.5	Register Description	54
2.6	Memory Organization	57
2.6.1	ROM	58
2.6.2	FLASH	58
2.6.2.1	FLASH Organization	58
2.6.2.2	FLASH Protection	58
2.6.2.3	Register Description	59

Table of Contents

2.6.3	RAM	60
2.6.4	Code Memory mapped SFRs	60
2.6.4.1	Register Description	60
2.6.5	Battery buffered data RAM	61
2.6.6	Special Function Registers	61
2.7	Microcontroller	65
2.7.1	Register Description	65
2.8	Interrupt Sources	67
2.8.1	External Interrupts 0 and 1	67
2.8.2	Timer Interrupts	68
2.8.3	I ² C Interface Interrupts	68
2.8.4	SPI Interface Interrupts	68
2.8.5	LF Receiver Interrupts	68
2.8.6	RF Encoder Interrupts	68
2.8.7	Register Description	69
2.9	RF Transmitter	72
2.9.1	Phase-Locked Loop (PLL)	72
2.9.2	Voltage-Controlled Oscillator (VCO)	73
2.9.3	Power Amplifier (PA)	73
2.9.4	ASK Modulator	73
2.9.5	Manchester/BiPhase Encoder with Bit Rate Generator	74
2.9.6	Register Description	76
2.10	LF Receiver	84
2.10.1	LF Receiver Analog Front End Configuration	84
2.10.1.1	Attenuator (AGC) and Data Filter / Data Slicer	85
2.10.1.2	LF Carrier Detector	85
2.10.1.2.1	Carrier Detector Threshold Calibration	86
2.10.1.2.2	Carrier Detector Filtering	87
2.10.2	LF Receiver On/Off Timer	88
2.10.2.1	LF Receiver On/Off Timer Calibration	88
2.10.3	LF Receiver Baseband Processor	90
2.10.3.1	Synchronizer	90
2.10.3.2	Bit rate Generator	91
2.10.3.3	LF Data Decoder	91
2.10.3.4	Wake-up Pattern Detector	91
2.10.3.5	LF Receiver Data Interface	91
2.10.3.5.1	8 bit data byte	92
2.10.3.5.2	Serial bit stream data	92
2.10.3.5.3	RAW data	92
2.10.3.5.4	RAW Carrier Detect	92
2.10.4	Register Description	93
2.11	Sensor Interfaces and Data Acquisition	108
2.11.1	Sensor Interface	108
2.11.1.1	Two Differential Highly Sensitive Interfaces to External Sensors	109
2.11.1.2	Interface to Other Signals	110
2.11.1.3	Reference Voltages	111
2.11.2	Temperature Sensor	111
2.11.3	Battery Voltage Monitor	111
2.11.4	Analog to Digital Converter (ADC)	112
2.11.4.1	ADC Timing	112
2.11.4.1.1	Clock Divider	113

Table of Contents

2.11.4.1.2	Sample Time Delay	113
2.11.4.1.3	Conversion Time	113
2.11.4.2	ADC Configuration	114
2.11.4.2.1	Reference- and Signal Voltage Selection	114
2.11.4.2.2	Single ended / Differential Conversion	114
2.11.4.2.3	Comparator Signal Inversion	114
2.11.4.2.4	Channel Gain Selection	114
2.11.4.2.5	Full Conversion or Sub Conversion	114
2.11.4.2.6	Analog Offset Correction of the Wheatstone Bridge Signals	114
2.11.4.3	ADC Conversion Result	115
2.11.5	Register Description	116
2.12	16 bit CRC (Cyclic Redundancy Check) Generator/Checker	123
2.12.1	Byte-aligned CRC Generation	123
2.12.2	Byte-aligned CRC Checking	124
2.12.3	Serial bit stream CRC Generation/Checking	124
2.12.4	Register Description	125
2.13	8 bit Pseudo Random Number Generator	128
2.13.1	Register Description	128
2.14	Timers	129
2.14.1	Timer 0 and Timer 1	129
2.14.1.1	Basic Timer Operations	129
2.14.1.2	Timer Modes	129
2.14.1.2.1	Timer/Counter 0/1 - Mode 0	129
2.14.1.2.2	Timer/Counter 0/1 - Mode 1	130
2.14.1.2.3	Timer/Counter 0/1 - Mode 2	130
2.14.1.2.4	Timer/Counter 0/1 - Mode 3	130
2.14.1.3	Timer/Counter 0/1 Interrupt support	131
2.14.1.4	Register Description	131
2.14.2	Timer 2 and Timer 3	136
2.14.2.1	Basic Timer Operations	136
2.14.2.2	Timer Modes	136
2.14.2.2.1	Timer 2/3 - Mode 0	136
2.14.2.2.2	Timer 2/3 - Mode 1	137
2.14.2.2.3	Timer 2/3 - Mode 2	138
2.14.2.2.4	Timer 2/3 - Mode 3	138
2.14.2.2.5	Timer 2/3 - Mode 4	139
2.14.2.2.6	Timer 2/3 - Mode 5	140
2.14.2.2.7	Timer 2/3 - Mode 6	140
2.14.2.2.8	Timer 2/3 - Mode 7	141
2.14.2.3	Register Description	142
2.15	General Purpose Input/Output (GPIO)	147
2.15.1	GPIO Port Configuration	147
2.15.2	Spike Suppression on Input Pins	147
2.15.3	External Wake-up on PP1-PP4 and PP6-PP9	147
2.15.4	Alternative Port Functionality	148
2.15.5	Register Description	150
2.16	I ² C Interface	156
2.16.1	Module Structure	156
2.16.2	I ² C Programming Instructions	157
2.16.2.1	Slave Mode Sequence (Polling Mode)	157
2.16.2.2	Slave Mode Sequence (Interrupt Mode)	157

Table of Contents

2.16.2.3	General Call Sequence	158
2.16.2.4	Master Mode Sequence (Polling Mode)	158
2.16.2.5	Master Mode Sequence (Interrupt Mode)	158
2.16.3	Register Description	160
2.17	SPI Interface	165
2.17.1	SPI Functionality	165
2.17.1.1	Full-Duplex Operation	166
2.17.1.2	Half-Duplex Operation	167
2.17.1.3	Data Modes	168
2.17.2	Module Structure	169
2.17.3	Interrupt Support	169
2.17.4	SPI Programming Instructions	170
2.17.4.1	Slave Mode Sequence	170
2.17.4.2	Master Mode Sequence	170
2.17.5	Register Description	170
2.18	PROGRAMMING Mode Operation	177
2.18.1	FLASH Write Line	177
2.18.2	FLASH Read Line	178
2.18.3	FLASH Erase	178
2.18.4	FLASH Check Erase Status	179
2.18.5	FLASH Set Code Lock (Lockbyte 2)	179
2.18.6	FLASH Set User Data Sector Lock (Lockbyte 3)	180
2.18.7	Read Status	180
2.19	DEBUG Mode Operation	181
2.19.1	ROM Debug Function	181
2.19.2	DEBUG Mode Commands	181
2.19.2.1	Set SFR	181
2.19.2.2	Read SFR	182
2.19.2.3	Set IData	182
2.19.2.4	Read IData	182
2.19.2.5	Set XData	182
2.19.2.6	Read XData	183
2.19.2.7	Set PC	183
2.19.2.8	Read PC	183
2.19.2.9	Single Step	183
2.19.2.10	Run Interruptible	183
2.19.2.11	Run until Breakpoint	184
3	Reference	185
3.1	Electrical Data	185
3.1.1	Absolute Maximum Ratings	185
3.1.2	Operating Range	186
3.1.3	Product Characteristics	186
3.1.3.1	Temperature Sensor	186
3.1.3.2	Battery Sensor	186
3.1.3.3	Supply Currents	187
3.1.3.4	RF-Transmitter	188
3.1.3.5	LF Receiver	189
3.1.3.6	Crystal oscillator	190
3.1.3.6.1	Crystal oscillator recommendation	191
3.1.3.7	12 MHz RC HF oscillator	192
3.1.3.8	2 kHz RC LP oscillator	192

Table of Contents

3.1.3.9	Interval Timer	193
3.1.3.10	Power On Reset	193
3.1.3.11	VMIN Detector	194
3.1.3.12	6k FLASH Code memory data	194
3.1.3.13	2 times 128 byte FLASH Data memory	194
3.1.3.14	ADC Interface	195
3.1.3.15	Digital I/O Pin	195
3.1.4	Matching Network for the Power Amplifier	196
4	Register Overview	197
	References	200
5	Package Outlines	201

List of Figures

Figure 1	Pin-outs of PMA51xx	16
Figure 2	PMA51xx Block Diagram	28
Figure 3	Operating Mode Selection of the PMA51xx after Reset	29
Figure 4	NORMAL mode - State Transition Diagram	30
Figure 5	Power On Reset - Operating Mode Selection	31
Figure 6	Block Diagram of the System Controller	35
Figure 7	Interval Timer Block Diagram	42
Figure 8	Calculation of Interval Timer period	42
Figure 9	PMA5110 Clock Concept	52
Figure 10	Formulas for Crystal selection dependent of RF Bands	53
Figure 11	Crystal Oscillator and FSK-Modulator Block Diagram	53
Figure 12	Memory Map	57
Figure 13	Naming Convention for Register Descriptions	61
Figure 14	RF Transmitter Block Diagram	72
Figure 15	Manchester/BiPhase Encoder	74
Figure 16	Diagram of the Different RF Encoder Modes	75
Figure 17	Calculation of RF bit rate timer value	76
Figure 18	LF Receiver	84
Figure 19	LF Receiver AFE Block Diagram	85
Figure 20	LF Receiver AFE Block Diagram	85
Figure 21	LF Receiver Carrier Detector Hold Time Behavior	86
Figure 22	Carrier Detector Threshold Calibration Timing (with "freeze")	87
Figure 23	LF Receiver Carrier Detector Filtering	88
Figure 24	Calculation of time base for LF Receiver On/Off Timer	88
Figure 25	Calculation of On time for LF Receiver On/Off Timer	89
Figure 26	Calculation of Off time for LF Receiver On/Off Timer	89
Figure 27	LF Receiver Baseband	90
Figure 28	LF Receiver Baseband Configurations	90
Figure 29	Calculation of LF Receiver bit rate	91
Figure 30	LF Receiver Data Decoder schemes	91
Figure 31	Block Diagram of the Sensor Interface	108
Figure 32	Wheatstone Bridge Sensor Connection	110
Figure 33	External Sensor Use Channel 2 as Reference Voltage	111
Figure 34	ADC Timing diagram (standard conversion)	112
Figure 35	ADC frequency calculation	113
Figure 36	ADC sample time delay	113
Figure 37	Generation of ADC clock and the sample time signal	113
Figure 38	Calculation of the ADC conversion time using full conversion	114
Figure 39	Calculation of the ADC conversion time using sub conversion	114
Figure 40	ADC offset voltage calculation	115
Figure 41	Calculation of single ended conversion	115
Figure 42	Calculation of differential conversion	115
Figure 43	CRC (Cyclic Redundancy Check) Generator/Checker	123
Figure 44	CRC (Cyclic Redundancy Check) Generator/Checker example	123
Figure 45	Example of Serial CRC Generation/checking	124
Figure 46	Timer/Counter 0, Mode 0, 13-Bit Timer/Counter	129
Figure 47	Timer/Counter 0, Mode 2: 8-bit Timer/Counter with auto-reload	130
Figure 48	Timer/Counter 0, Mode 3: Two 8-bit Timers/Counters	131
Figure 49	Timer 2/3 - Mode 0	136

List of Figures

Figure 50	Timer 2/3 - Mode 1	137
Figure 51	Timer 2/3 - Mode 2	138
Figure 52	Timer 2/3 - Mode 3	139
Figure 53	Timer 2/3 - Mode 4	139
Figure 54	Timer 2/3 - Mode 5	140
Figure 55	Timer 2/3 - Mode 6	141
Figure 56	Timer 2/3 - Mode 7	141
Figure 57	Logical description of external wake-ups and internal pull-up/pull-down resistors	148
Figure 58	I ² C module structure	156
Figure 59	Calculation of I ² C baud rate	160
Figure 60	SPI principle	165
Figure 61	Full-Duplex configuration	166
Figure 62	Half-Duplex Configuration.	167
Figure 63	SPI data modes	168
Figure 64	SPI module structure	169
Figure 65	Calculation of SPI baud rate.	171
Figure 66	Legend for I ² C-Commands in PROGRAMMING mode	177
Figure 67	FLASH Write Line command	178
Figure 68	FLASH Read Line command	178
Figure 69	FLASH Erase command	178
Figure 70	FLASH Erase: Sector byte	178
Figure 71	FLASH Check Erase Status command.	179
Figure 72	FLASH Check Erase Status: Sector byte	179
Figure 73	FLASH Check Erase Status: Status byte	179
Figure 74	FLASH Set Lockbyte 3 command.	180
Figure 75	Read Status command	180
Figure 76	Read Status: Status byte	180
Figure 77	Legend for I ² C communication in DEBUG	181
Figure 78	Set SFR command	181
Figure 79	Read SFR command	182
Figure 80	Set IData command	182
Figure 81	Read IData command.	182
Figure 82	Set XData command.	182
Figure 83	Read XData command	183
Figure 84	Set PC command	183
Figure 85	Read PC command	183
Figure 86	Single Step	183
Figure 87	Run Interruptible	183
Figure 88	Run until Breakpoint	184
Figure 89	Matching network for the power amplifier	196
Figure 90	Package Outline PG-TSSOP-38.	201

List of Tables

Table 1	PMA51xx and PMA71xx Family	14
Table 2	Abbreviations for Pin Type	17
Table 3	Pin Description	17
Table 4	Operating Mode Selection after Reset	30
Table 5	State Transitions in NORMAL mode	33
Table 6	Status of Important PMA5110 Blocks in Different States	34
Table 7	Registers Overview	37
Table 8	Registers Overview	43
Table 9	Registers Overview	45
Table 10	Registers Overview	54
Table 11	Registers Overview	60
Table 12	Special Function Registers Overview	61
Table 13	Registers Overview	65
Table 14	Interrupt Vector Locations	67
Table 15	Registers Overview	69
Table 16	Registers Overview	76
Table 17	Registers Overview	93
Table 18	Selection of the Gain Factor	109
Table 19	Registers Overview	116
Table 20	Registers Overview	125
Table 21	Registers Overview	131
Table 22	Registers Overview	142
Table 23	GPIO Port Configuration	147
Table 24	I/O Port 1 - Alternative Functionality	148
Table 25	Registers Overview	150
Table 26	Registers Overview	160
Table 27	Registers Overview	170
Table 28	FLASH Erase: Sector byte	178
Table 29	FLASH Check Erase Status: Sector byte	179
Table 30	FLASH Check Erase Status: Status byte	179
Table 31	Read Status: Status byte	180
Table 32	Absolute Maximum Ratings	185
Table 33	Operating Range	186
Table 34	Temperature Sensor Characteristics	186
Table 35	Battery Sensor Characteristics	186
Table 36	Supply Currents	187
Table 37	RF Transmitter	188
Table 38	LF Receiver, $V_{Bat} = 2.1-3.6V$	189
Table 39	Crystal oscillator	190
Table 40	NDK crystal oscillator recommendation for PMA51xx	191
Table 41	12 MHz RC HF oscillator	192
Table 42	2 kHz RC LP oscillator	192
Table 43	Interval Timer	193
Table 44	Power On Reset	193
Table 45	VMIN Detector	194
Table 46	6k FLASH Code memory data	194
Table 47	2 times 128 byte FLASH Data memory	194
Table 48	ADC Interface	195
Table 49	Digital I/O Pin	195

List of Tables

Table 50	Values of the matching network for the power amplifier	196
Table 51	Register Overview	197

1 Product Description

1.1 Overview

The SmartLEWIS™ MCU family comprises an ASK/FSK multiband transmitter for the sub 1GHz ISM frequency bands with an embedded 8051 microcontroller as base functionality. Additionally, the highly integrated single chip family has internal sensors and optional peripheral functions like an analog to digital converter (ADC) and a LF Receiver on chip. The operating voltage range of 1.9 to 3.6 V, the high efficiency Power Amplifier and an advanced power control system make the PMA51xx family ideal for battery operated applications where low current consumption is necessary. The pin-compatible product family requires only a few external components and is the basis for flexible wireless control transmitter platforms enabling applications for different frequency bands, output power levels and feature sets based on only one design - just through different mounting options.

The multiband ASK/FSK transmitter for 315/434/868/915 MHz frequency bands contains a fully integrated VCO, a PLL synthesizer, an ASK/FSK modulator and a high efficiency Power Amplifier with selectable output power. Fine tuning of the center frequency can be done by an on-chip capacitor bank.

The integrated microcontroller is instruction set compatible to the standard 8051 processor. It can be clocked with an internal 12 MHz RC HF or an external oscillator. 6 clock cycles are needed for the execution of one instruction. This results in 2 MIPS¹⁾ when using the 12 MHz RC HF oscillator. The microcontroller is equipped with various peripherals like a hardware Manchester/BiPhase Encoder/Decoder and a CRC Generator/Checker. To store the microcontroller application program code, a 6 kbyte on-chip FLASH memory is integrated. This FLASH memory is also used for saving the unique ID-number of the chip. A comprehensive software function library with high level commands in ROM allows easy and fast time to market development. The library provides many powerful functions like AES-encryption and EEPROM emulation, what helps to reduce the user code size.

Additional peripherals are an integrated temperature sensor and a low battery voltage sensor. Measurements via these internal sensors and reading signals from analog inputs (e.g. from an external analog sensor) are performed under software control.

Depending on the product variant, PMA51xx offers an embedded multi-channel 10-bit analog to digital converter with flexible high-gain settings as interface for a broad variety of analog sensors and an integrated 125 kHz LF Receiver. The LF Receiver enables wireless wake-up in battery operated applications with ultra-long-lifetime or even contactless configuration of the device.

1) MIPS .. Million Instructions Per Second

1.2 PMAx1xx Product Family

The PMAx1xx product family contains various product variants listed in [Table 1 “PMA51xx and PMA71xx Family” on Page 14](#).

Note: This data sheet documents the full feature set of the PMA5110, which has the full feature set of the PMA51xx product family available. When using the PMA51xx family data sheet for product variants other than the PMA5110, please keep in mind that not all of the features and data described are relevant for these other members of the family.

Following table shows the functional differences of the PMA51xx and PMA71xx family members:

Table 1 PMA51xx and PMA71xx Family

Product Name	Ordering Code	RF Transmitter	Embedded 8051 MCU	ADC	125 kHz LF Receiver	Automotive Qualified
PMA7110	SP000430596	X	X	X	X	no
PMA7107	SP000450412	X	X		X	no
PMA7106	SP000450410	X	X	X		no
PMA7105	SP000450408	X	X			no
PMA5110	SP000373573	X	X	X	X	yes
PMA5105	SP000463432	X	X			yes

The PMA51xx products are supporting a temperature range from -40 to +125°C and are full automotive qualified, tailored for automotive applications and industrial applications in harsh environment. Additionally, Infineon offers the PMA71xx product family with a temperature range of -40 to +85°C, tailored for consumer and industrial applications.

1.3 Applications

- Remote Keyless Entry (RKE)
- Security and alarm systems requiring high quality standards
- Industrial controls in harsh environments
- Wireless sensing

1.4 Key Features

General:

- Supply voltage range from 1.9 V up to 3.6 V
- Operating temperature range from -40 to +125°C
- Low power down current consumption < 0.6 µA
- Advanced power control system for lowest system current consumption, switching the microcontroller or transmitter part into POWER DOWN or IDLE state whenever possible
- PG-TSSOP-38 package

Transmitter:

- Multiband RF Transmitter for ISM frequency band 315/434/868/915 MHz
- SW configurable transmit power of 5/8/10 dBm into 50 Ohm load
- Selectable transmit data rates up to 32 kbit/s (64 kchips/s) for the temperature range -40°C to +85°C and 20 kbit/s (40 kchips/s) for temperatures above +85°C
- RF Encoder supporting Manchester-, BiPhase- or NRZ coded data (Chip Mode)

- ASK/FSK modulation capability
- FSK frequency deviation up to 100 kHz
- Fully integrated VCO and PLL synthesizer
- Crystal oscillator tuning on chip

Microcontroller:

- 8051 instruction set compatible microcontroller (cycle-optimized)
- 6 kbyte free programmable FLASH code memory
- 2 blocks of 128 byte FLASH data memory, alternatively usable as 31 byte emulated EEPROM
- ROM embedded software function library with preprogrammed functions and high level commands for easy programming
- 128 bit AES (Advanced Encryption Standard) embedded as software function
- 256 bytes RAM (128 bytes configurable to keep content in POWER DOWN state)
- 16 bytes XData memory (supplied in POWER DOWN state)
- 2 MIPS when using internal 12 MHz RC HF oscillator

Peripherals:

- 125 kHz ASK LF Receiver
- LF Receiver data rate for typical 3.9 kbit/s (Manchester/BiPhase coded)
- 10 bit ADC with 3 pair differential channels and flexible high-gain settings (e.g. as inputs for external sensors)
- 10 free programmable bidirectional General Purpose Input Output pins (GPIO) with on-chip pull-up/pull-down resistors. 8 of them have wake-up functionality
- On-chip temperature sensor
- On-chip voltage sensor for low battery voltage measurement
- Brownout Detector
- Manchester/BiPhase Encoder and Decoder
- 16 bit hardware CRC Generator
- 8 bit Pseudo Random Number Generator
- I²C bus interface
- SPI bus interface

Miscellaneous:

- Watchdog Timer
- 4 independent 16 bit timers
- Wake-up from POWER DOWN state possible by different sources: Interval Timer, Watchdog Timer, LF Receiver or external wake-up sources connected to GPIOs
- On-chip debugging via I²C interface
- 48 bit unique-ID on chip

1.5 Pin Diagram

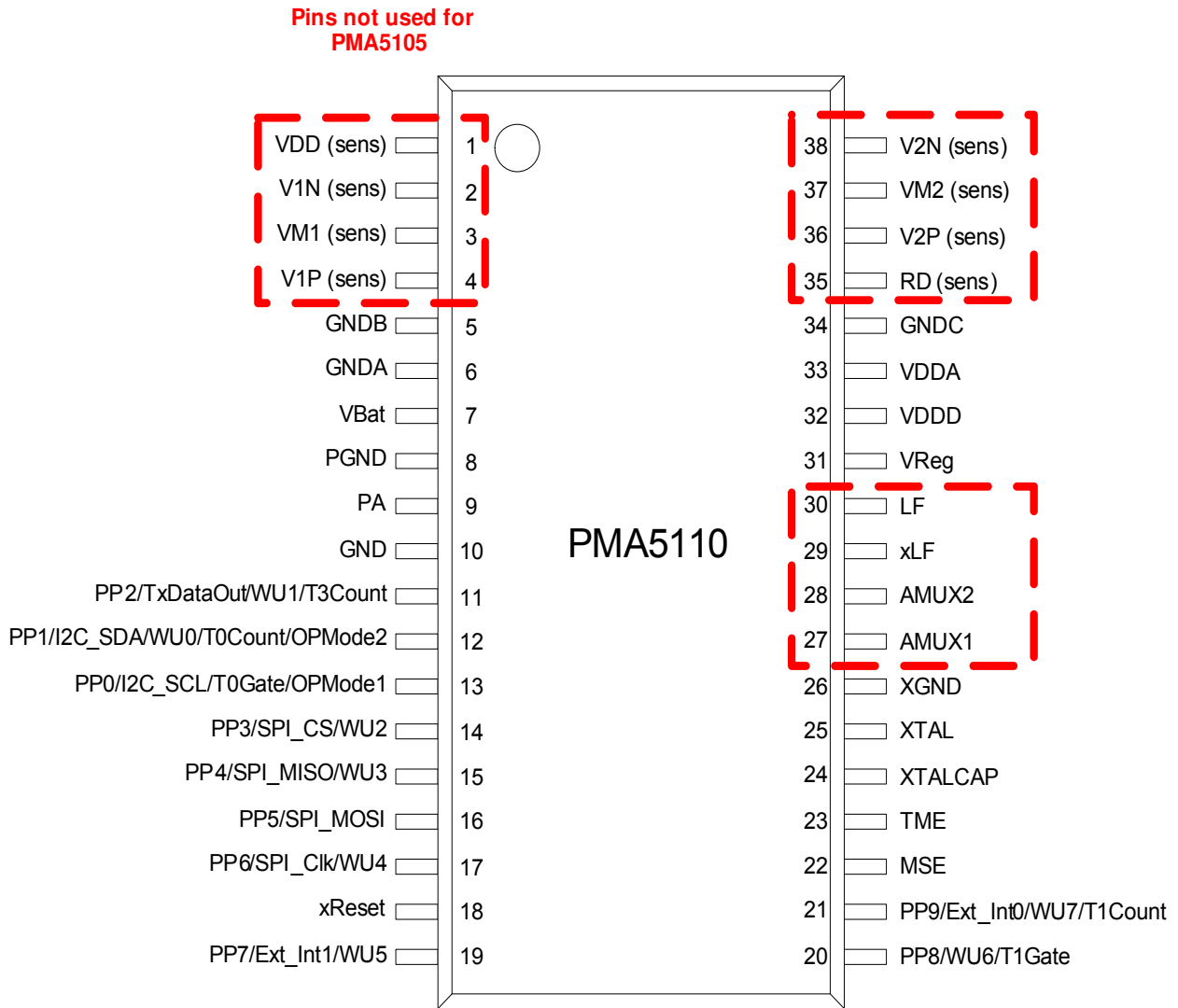

Figure 1 Pin-outs of PMA51xx

1.6 Pin Description

Abbreviations

Standard abbreviations for I/O are shown in [Table 2](#).

Table 2 Abbreviations for Pin Type

Abbreviations	Description
I	Standard input-only pin. Digital levels.
I/O	I/O is a bidirectional input/output signal.
AI	Input. Analog levels.
AO	Output. Analog levels.
AI/O	Input or Output. Analog levels.
PWR	Power
GND	Ground

Table 3 Pin Description

Pin No.	Name	Pin Type	Buffer Type	Function
1	VDD_sens	AO	Supply_output 	Sensor Bridge Positive Supply Output of V_{Reg} during measurement.
2	V1N_sens	AI	Analog 	Channel 6, High-gain ADC Input Negative input connect to sensor bridge. Output of wheatstone bridge sensor

Table 3 Pin Description (cont'd)

Pin No.	Name	Pin Type	Buffer Type	Function
3	VM1_sens	GND	Supply	Channel 6, High-gain ADC Input Sensor bridge negative supply. Same voltage as chip GND.
4	V1P_sens	AI	Analog	Channel 6, High-gain ADC Input Positive input connect to sensor bridge. Output of wheatstone bridge sensor
5	GNDB	GND	Supply	Ground
6	GNDA	GND	Supply	Ground

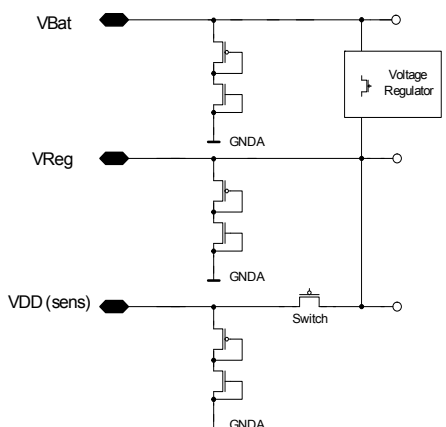
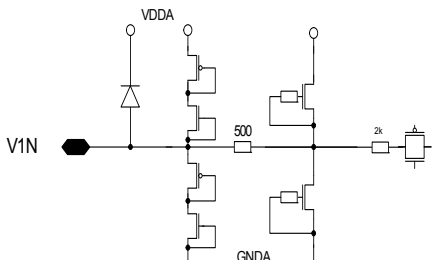
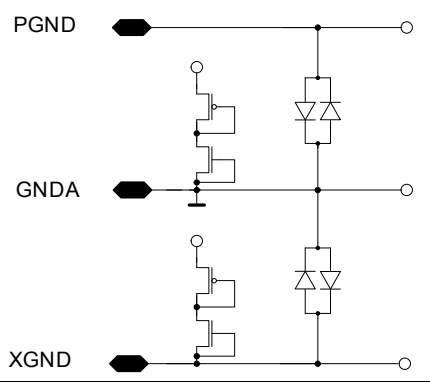
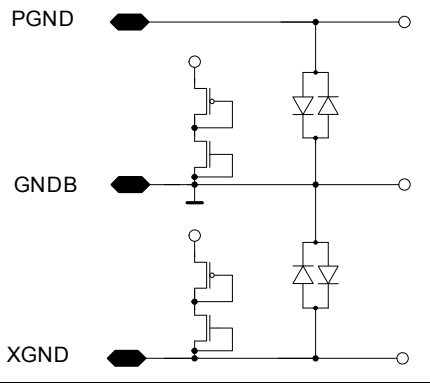
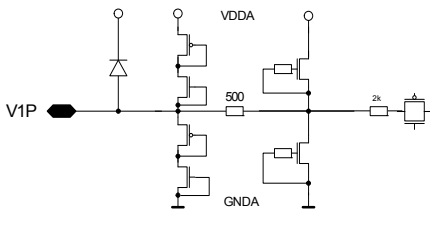
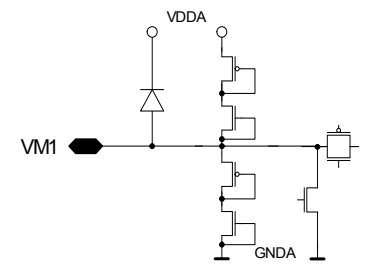

Table 3 Pin Description (cont'd)

Pin No.	Name	Pin Type	Buffer Type	Function
7	VBat	PWR	Supply 	Battery Supply Voltage Regulators
8	PGND	GND	Supply 	Power Amplifier Ground Double bond
9	PA	AO	Analog 	Power Amplifier Output Stage
10	GND	GND	Supply(Analog) 	Ground

Table 3 Pin Description (cont'd)

Pin No.	Name	Pin Type	Buffer Type	Function
11	PP2/TxDataOut/ WU1/T3Count/	I/O	Digital	<p>PP2</p> <ul style="list-style-type: none"> -) Serial output of Manchester / Biphase encoded data. -) GPIO -) External wake-up source 1 -) Clock source for Timer 3 -) Internal, switchable pull-up/pull-down.
12	PP1/I2C_SDA/ WU0/T0Count/ OPMode2	I/O	Digital	<p>PP1</p> <ul style="list-style-type: none"> -) I2C bus interface data -) GPIO -) External wake-up source 0 -) Clock source for Timer 0 -) Select operation mode -) Internal, switchable pull-up/pull-down.
13	PP0/I2C_SCL/ T0Gate/OPMode1	I/O	Digital	<p>PP0</p> <ul style="list-style-type: none"> -) I2C bus interface clock -) GPIO -) External enable for Timer 0 -) Select operation mode -) Internal, switchable pull-up/pull-down.

Table 3 Pin Description (cont'd)

Pin No.	Name	Pin Type	Buffer Type	Function
14	PP3/SPI_CS/WU2	I/O	Digital	<p>PP3</p> <ul style="list-style-type: none"> -) SPI bus interface chip select -) GPIO -) External wake-up source 2 -) Internal, switchable pull-up/pull-down.
			<p>The diagram shows a bidirectional digital buffer for Pin 14. The pin is connected to a data bus. It features a pull-up resistor of 250k to VBat and a pull-down resistor of 500 to GND. The buffer includes a Pullup/Pulldown/Tristate driver and a Combinational Logic block. The logic block is connected to PPS3, PPO3, PPD3, SPIEn, and PPI3/SPI_CS.</p>	
15	PP4/SPI_MISO/WU3	I/O	Digital	<p>PP4</p> <ul style="list-style-type: none"> -) SPI bus interface master in slave out -) GPIO -) External wake-up source 3 -) Internal, switchable pull-up/pull-down.
			<p>The diagram shows a bidirectional digital buffer for Pin 15. The pin is connected to a data bus. It features a pull-up resistor of 250k to VBat and a pull-down resistor of 500 to GND. The buffer includes a Pullup/Pulldown/Tristate driver and a Combinational Logic block. The logic block is connected to PPS4, PPO4, PPD4, SPI_MISO, SPIEn, and PPI4.</p>	
16	PP5/SPI_MOSI	I/O	Digital	<p>PP5</p> <ul style="list-style-type: none"> -) SPI bus interface master out slave in -) GPIO -) Internal, switchable pull-up/pull-down.
			<p>The diagram shows a bidirectional digital buffer for Pin 16. The pin is connected to a data bus. It features a pull-up resistor of 250k to VBat and a pull-down resistor of 500 to GND. The buffer includes a Pullup/Pulldown/Tristate driver and a Combinational Logic block. The logic block is connected to PPS5, PPO5, PPD5, SPI_MOSI, SPIEn, and PPI5.</p>	

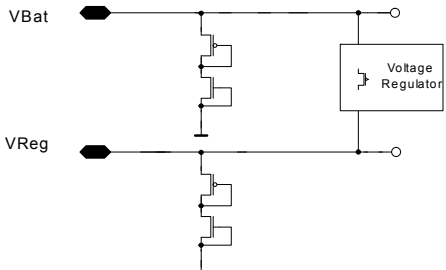
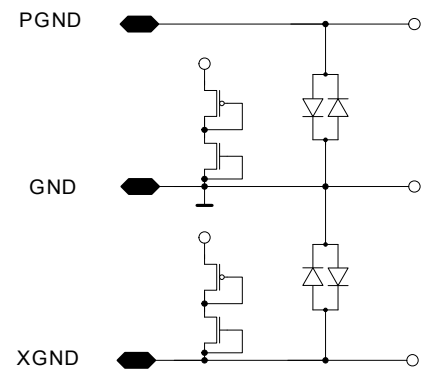
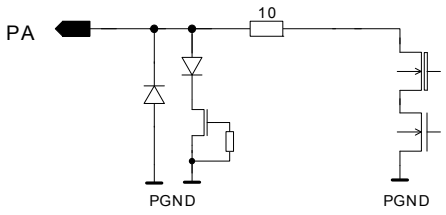
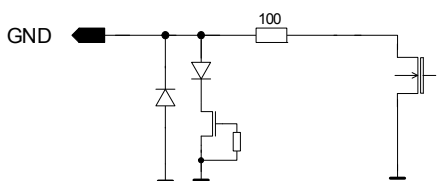
Table 3 Pin Description (cont'd)

Pin No.	Name	Pin Type	Buffer Type	Function
17	PP6/SPI_Clk/WU4	I/O	Digital	<p>PP6</p> <ul style="list-style-type: none"> -) SPI bus interface clock -) GPIO -) External wake-up source 4 -) Internal, switchable pull-up/pull-down.
18	xReset	I	Digital	<p>External Reset Low active</p>
19	PP7/Ext_Int1/WU5	I/O	Digital	<p>PP7</p> <ul style="list-style-type: none"> -) GPIO -) External interrupt source 1 -) External wake-up source 5 -) Internal, switchable pull-up/pull-down.

Table 3 Pin Description (cont'd)

Pin No.	Name	Pin Type	Buffer Type	Function
20	PP8/WU6/T1Gate	I/O	Digital	<p>PP8</p> <ul style="list-style-type: none"> -) GPIO -) External wake-up source 6 -) External enable for Timer 1 -) Internal, switchable pull-up/pull-down.
21	PP9/Ext_Int0/WU7/T1Count	I/O	Digital	<p>PP9</p> <ul style="list-style-type: none"> -) GPIO -) External interrupt source 0 -) External wake-up source 7 -) Clock source for Timer 1 -) Internal, switchable pull-up/pull-down.
22	MSE	I	Digital	<p>Mode Select Enable</p> <p>High active, set to GND in NORMAL Mode.</p>

Table 3 Pin Description (cont'd)

Pin No.	Name	Pin Type	Buffer Type	Function
23	TME	I	Digital	<p>Test Mode Enable, n.a. for Normal Application Has to be set to GND in NORMAL Mode</p>
24	XTALCAP	AI	Analog	<p>Crystal Oscillator Load Capacitance</p>
25	XTAL	AI	Analog	<p>Crystal Oscillator Input</p>
26	XGND	GND	Supply	<p>Crystal Oscillator Ground</p>

Table 3 Pin Description (cont'd)

Pin No.	Name	Pin Type	Buffer Type	Function
27	AMUX1	AI	Analog 	Additional Differential ADC Standard Input1 for External Sensor Connect to GND if not use.
28	AMUX2	AI	Analog 	Additional Differential ADC Standard Input2 for External Sensor Connect to GND if not use.
29	xLF	AI	Analog 	Differential LF Receiver Input2 125kHz Input.
30	LF	AI	Analog 	Differential LF Receiver Input1
31	VReg	AO	Supply 	Internal Voltage Regulator Output Connect to decoupling capacitor ($C_{BCAP}=100\text{ nF}$) Regulated Power supply.

Table 3 Pin Description (cont'd)

Pin No.	Name	Pin Type	Buffer Type	Function
32	VDDD	PWR	Supply 	Digital Supply
33	VDDA	PWR	Supply 	Analog Supply
34	GNDC	GND	Supply 	Ground
35	RD_sens	AI	Analog 	Diagnostic Resistor Use only by having diagnostic resistor on sensor bridge for high-gain ADC input, otherwise no connection
36	V2P_sens	AI	Analog 	Channel 7, High-gain ADC Input Positive input connect to sensor bridge. Output of Wheatstone bridge sensor.

Table 3 Pin Description (cont'd)

Pin No.	Name	Pin Type	Buffer Type	Function
37	VM2_sens	GND	Supply 	Channel 7, High-gain ADC Input Sensor bridge negative supply. Same voltage as chip GND.
38	V2N_sens	AI	Analog 	Channel 7, High-gain ADC Input Negative input connect to sensor bridge. Output of Wheatstone bridge sensor.

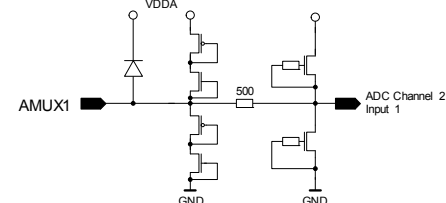
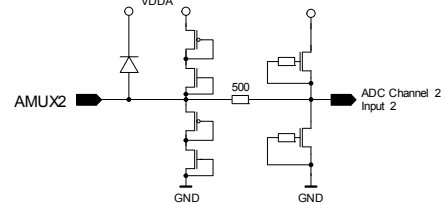
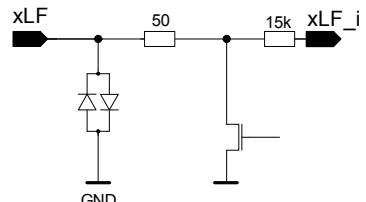
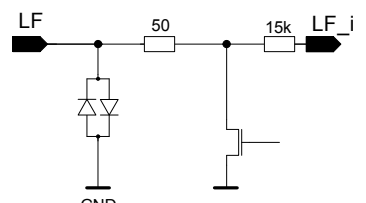
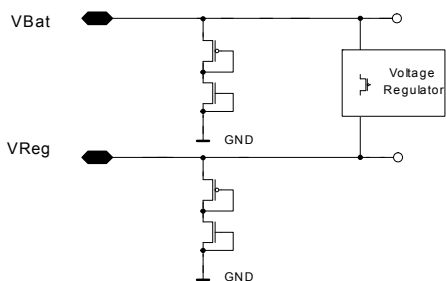
1.7 Functional Block Diagram

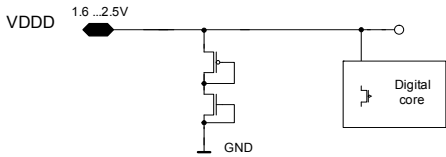
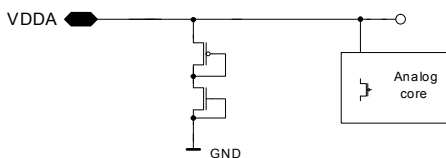
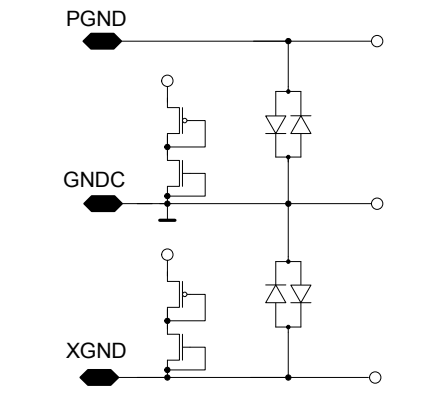
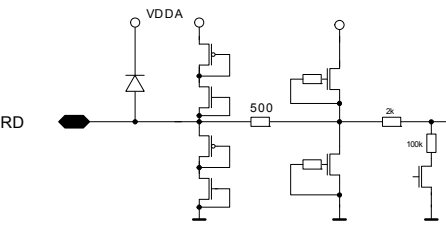
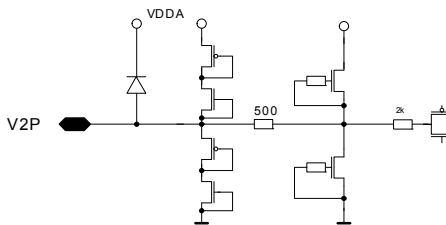
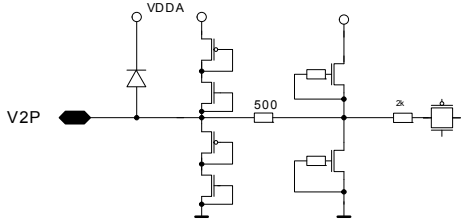
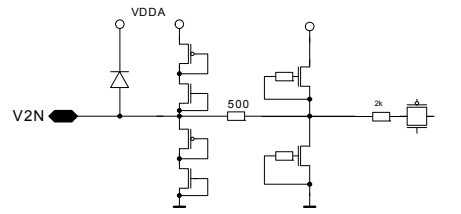
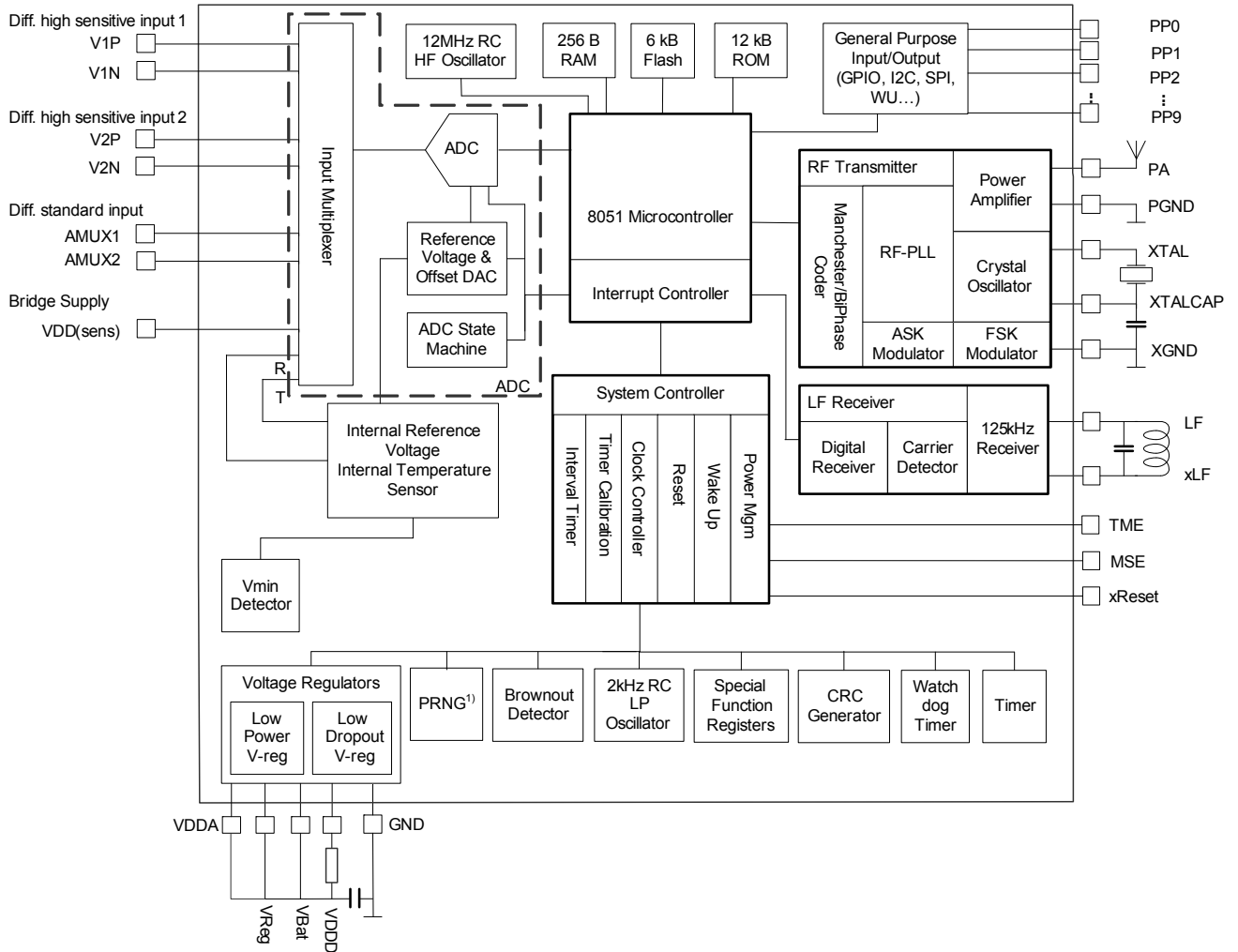

1) PRNG.. Pseudo Random Number Generator

Figure 2 PMA51xx Block Diagram

2 Functional Description

2.1 Operating Modes and States

The PMA51xx can be operated in three different operating modes.

- NORMAL mode
- PROGRAMMING mode
- DEBUG mode

2.1.1 Operating Mode Selection

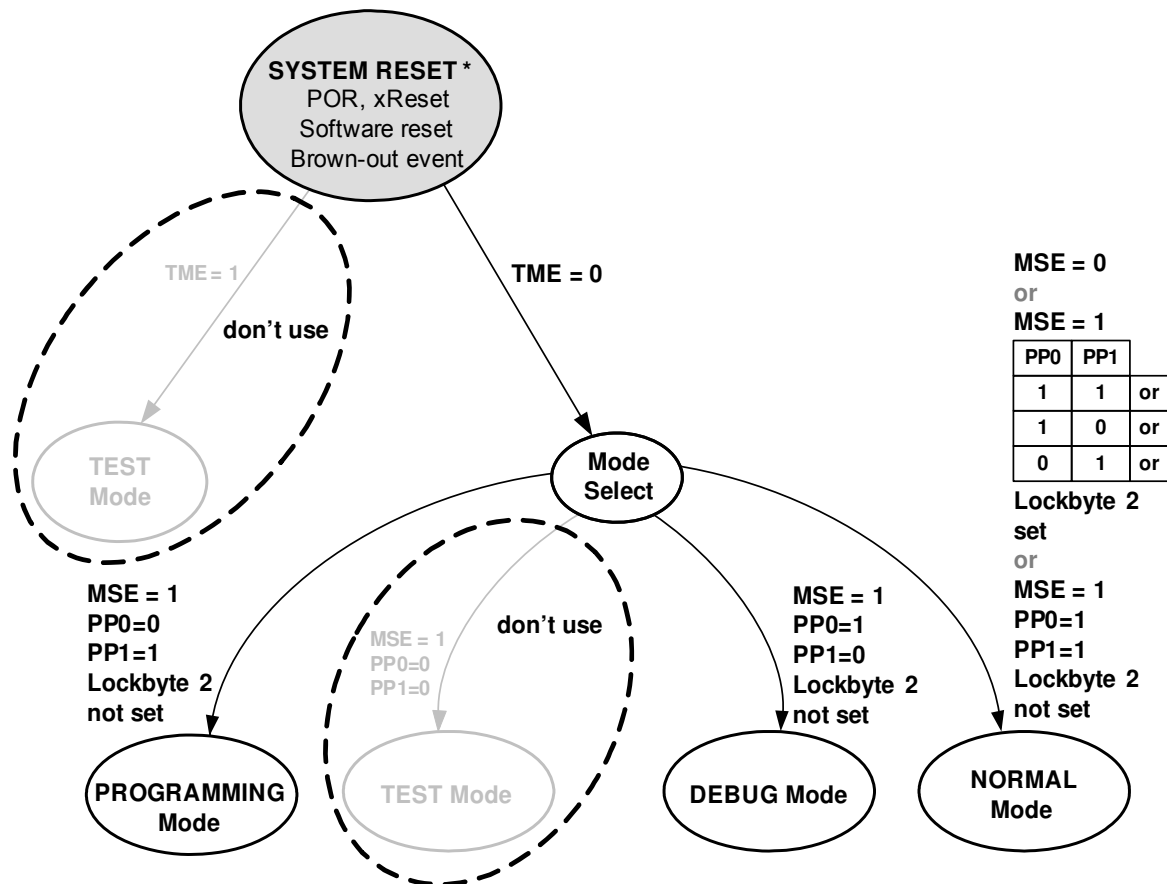

*Note: Whenever TME is set to high the current operation mode is left and TEST Mode is entered, regardless if there was a reset event or not !

Figure 3 Operating Mode Selection of the PMA51xx after Reset

The Mode Select is entered after the System Reset expires. The levels on the I/O pins PP0 and PP1 are latched by the System Controller and read by the operating system to determine the mode of operation of the device according to [Table 4 “Operating Mode Selection after Reset” on Page 30](#). [Figure 3 “Operating Mode Selection of the PMA51xx after Reset” on Page 29](#) shows how the MSE and Lockbyte 2 are also checked to determine the operating mode. The MSE, PP0, and PP1 levels must not change after reset release during the whole t_{MODE} period (see [Figure 5 “Power On Reset - Operating Mode Selection” on Page 31](#)).

Table 4 Operating Mode Selection after Reset

TME	MSE	Lockbyte 2	PP0	PP1	Operating Mode	Device Control	Hardware Restrictions
0	0	x	x	x	NORMAL	CPU executing from 4000 _H	FLASH write access depends on Lockbyte setting
0	1	x	0	0	TEST ¹⁾		
0	1	Not set	0	1	PROGRAMMING	PROGRAMMING mode handler	None
0	1	Set	0	1	NORMAL	CPU executing from 4000 _H	FLASH write restriction ²⁾
0	1	Not set	1	0	DEBUG	DEBUG mode handler	FLASH write disabled
0	1	Set	1	0	NORMAL	CPU executing from 4000 _H	FLASH write restriction ²⁾
0	1	x	1	1	NORMAL	CPU executing from 4000 _H	FLASH write restriction ²⁾

- 1) Do not use
- 2) FLASH programming and erasing is possible via Library functions

Note: FLASH protection is done by hardware.

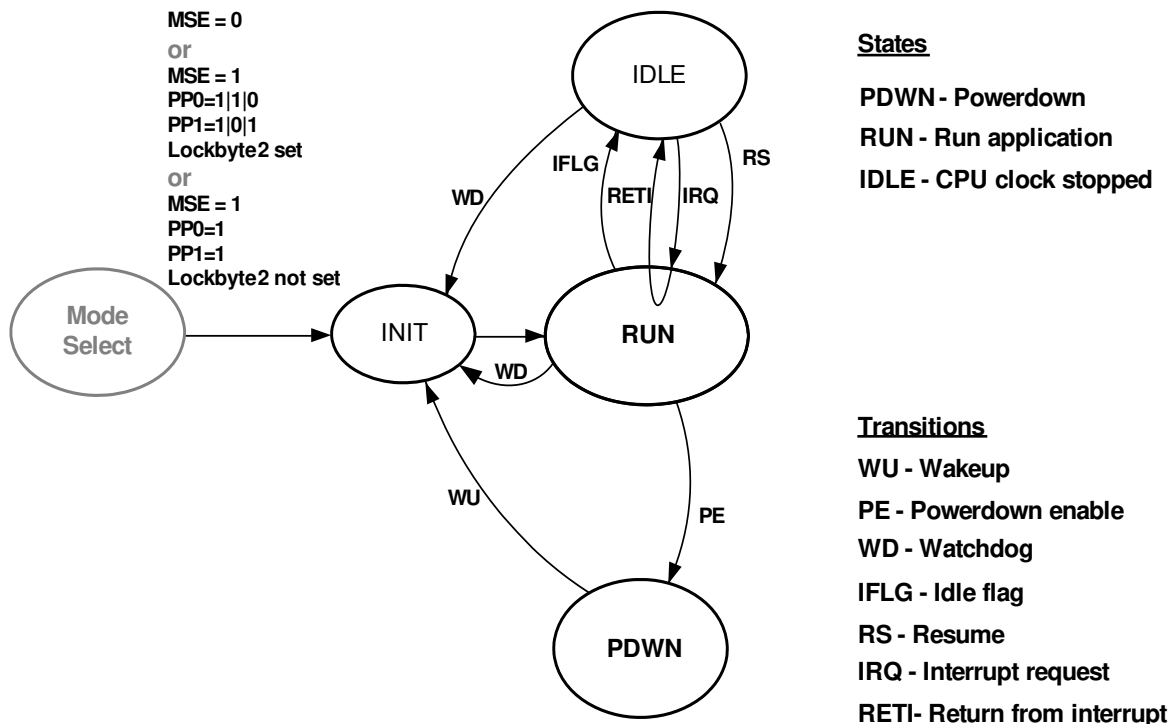

Figure 4 NORMAL mode - State Transition Diagram

For low power consumption the PMA51xx supports different operating states - RUN state, IDLE state and POWER DOWN state. The device operation in these states is as described below.

Transitions between these states are either controlled by application software or managed automatically by the System Controller.

- PDWN: Power down (CPU and peripherals are not supplied)
- IDLE: CPU clock stopped, peripherals are still running

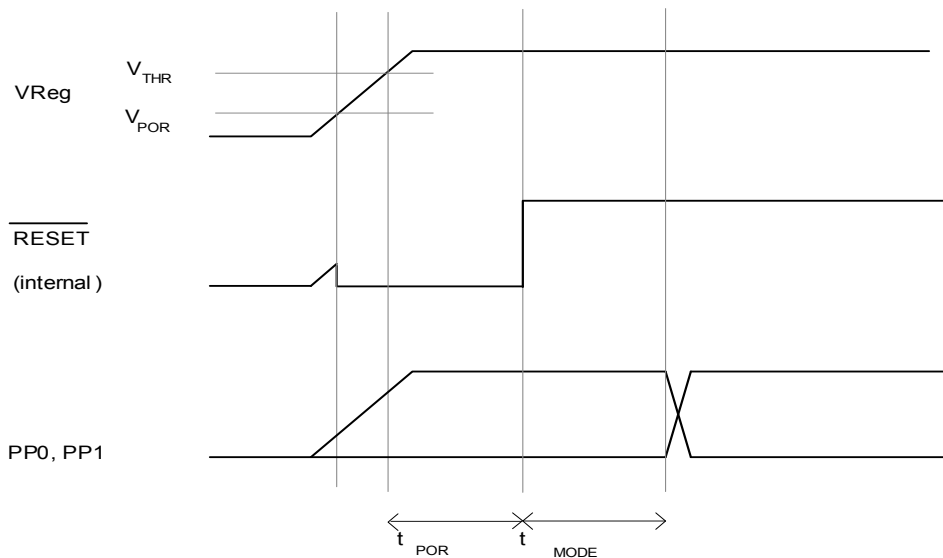

Figure 5 Power On Reset - Operating Mode Selection

During the time interval t_{MODE} , the levels of PP0, PP1 and MSE are read, and the operation mode of the device determined according to [Table 4 “Operating Mode Selection after Reset” on Page 30](#). The levels on these pins must be stable during the whole t_{MODE} period.

The PMA51xx's Power-On Reset circuit is activated if V_{reg} rises above V_{POR} . The internal blocks are held in Reset state until V_{reg} exceeds the level of V_{THR} .

When this Reset state is released, a further time of t_{MODE} is needed for reading the levels on PP0, PP1, and MSE. After t_{MODE} has elapsed, the device starts operation in the selected mode.

Note: See [Table 44 “Power On Reset” on Page 193](#) for details on Power-On Reset characteristics.

2.1.2 State Description

2.1.2.1 INIT state

This is a transient state after the System Reset, which is entered when the settings of PP0, PP1, MSE, TSE, and the Lockbyte 2 lead to NORMAL mode (please refer to [Table 4 “Operating Mode Selection after Reset” on Page 30](#)). It is also a transient state in NORMAL mode before the state change between PDWN and RUN or when a watchdog reset occurs in IDLE or RUN state. In INIT state, the relevant SFRs get reset to their default values. Then the application program in FLASH is started at 4000_H and the device enters RUN state.

2.1.2.2 RUN state

In the RUN state, the CPU executes the FLASH code. Peripherals are on or off according to the application program and the Watchdog Timer is active. All wake-up events except in ExtWUFs are ignored in the RUN state but the corresponding wake-up flags get set and can be read and cleared. Activity on the external wake-up pins can be monitored in the corresponding SFR P1In or P3In.

2.1.2.3 IDLE state

In the IDLE state, the CPU clock is disabled but peripherals (Timers, ADC, RF-TX, LF-RX, SPI and I²C interface) continue normal operation. If a resume event occurs, the RUN state is reentered immediately. The Watchdog Timer is active and reset automatically when entering IDLE state. All wake-up events are ignored in IDLE state, but the corresponding flags are set if a wake-up occurs and can be evaluated once the device returns to the RUN state.

If a peripheral requests an interrupt or an external interrupt occurs, the IDLE state is left for RUN state, the interrupt service routine is executed, and on the next RETI (return from interrupt) instruction the IDLE state is re-entered in case no resume event has occurred in between.

Resume events

The resume source can be identified by reading the Resume Event Flag, REF. Resume events may occur on the following events:

- RF Transmitter buffer empty
- RF transmission finished
- LF Receiver buffer full
- Timer 2 underflow
- A/D conversion finished
- 2 kHz RC LP oscillator calibration finished
- Clock change from 12 MHz RC HF oscillator to crystal oscillator finished

Interrupt requests

Interrupts during IDLE state may be requested by embedded peripherals or external events.

- External (pin) interrupt 0/1
- Timer 0/1/2/3
- I2C interface
- SPI interface
- LF Receiver
- Manchester/Biphase Encoder

2.1.2.4 POWER DOWN state (PDWN)

In the POWER DOWN state, the CPU and its peripherals are powered down. The System Controller, the XData memory, and optionally the lower 128-byte internal RAM are kept powered. Furthermore some SFRs are kept powered in the POWER DOWN state (see [Table 12 “Special Function Registers Overview” on Page 61](#)). The LF Receiver will be switched on periodically if the LF On/Off Timer is enabled. Wake-up flags are cleared automatically when going to POWER DOWN.

Wake-up Events

A wake-up event occurs when a peripheral or external source causes the system to power up again. The wake-up source can be identified by reading SFRs WUF and ExtWUF. Wake-up Events may occur on following events:

- At least one of the External wake-up pins changed its state to the configured one
- Interval Timer underflow occurred
- LF Receiver carrier detected
- LF Receiver pattern matched
- LF Receiver sync matched

2.1.2.5 State Transitions

With reference to [Figure 4 “NORMAL mode - State Transition Diagram” on Page 30](#), the following state transitions can occur:

Table 5 State Transitions in NORMAL mode

State Transition	Description
RUN state => IDLE state (IFLG)	The application program sets SFR bit CFG0.5[IDLE] ¹⁾ to enter IDLE state. (see Configuration Register 0 on page 46) <i>Note: If no peripheral that can create a RESUME event is active, IDLE state will not be entered and the application will continue operation.</i>
IDLE state => RUN state (RS, IRQ)	RS: A peripheral unit (Timer 2, ADC, RF Transmitter, LF Receiver, system clock source switch) creates a resume event. The application continues with the instruction after the Idle bit setting (see Resume Event Flag Register on page 39). IRQ: An interrupt occurs. This interrupt allows the immediate execution of the interrupt service routine. With the return from interrupt instruction, the device returns to IDLE state if no resume event has been generated in between.
IDLE state => INIT state (WD ²⁾) RUN state => INIT state (WD)	If the Watchdog Timer elapsed, the application will restart by initialization of some SFRs. Only the SFRs which are not supplied in POWER DOWN state are initialized after the Watchdog Timer elapsed (see Table 12 “Special Function Registers Overview” on Page 61). The Watchdog Timer wake-up may be identified by Wake-up Flag Register on page 40
RUN state => POWER DOWN state (PDWN)	Entering this state is always software-controlled by setting CFG0.7[PDWN]. The application program calls a Library function to enter POWER DOWN state whenever needed.
POWER DOWN state => INIT state	A wake-up event will restart the application and set the SFR WUF resp. ExtWUF accordingly. The Watchdog Timer is re-initialized (see External Wake-up Flag Register on page 37).
INIT state => RUN state	This state change is initiated automatically by the System Controller as soon as INIT state is finished.

1) It is mandatory that the instruction setting the CFG0.5[IDLE] is followed by a NOP instruction.

2) WD .. Watchdog Timer

Wake-up duration from POWER DOWN state through INIT state to RUN state typically lasts 1410 μ s. The time is the sum of the time for the power supply to get stable (100 μ s), the startup time of the oscillator (1150 μ s) and the time for the operating system to get initialized (160 μ s @ 12-MHz CPU clock).

2.1.2.6 Status of PMA5110 Blocks in Different States

Depending of the actual state in NORMAL mode, the internal blocks of the PMA5110 are active, inactive or have no supply to reduce power consumption. The next table gives an overview of the various blocks in the different device states.

Table 6 Status of Important PMA5110 Blocks in Different States

Peripheral Unit	RUN state	IDLE state	POWER DOWN state
Power-On Reset	Active	Active	Active
Brown-Out Detector	Active	Active	Inactive; power down
Low-Power voltage supply	Active	Active	Active
System Controller	Active	Active	Active
Wake-up Logic	Active	Active	Active
CPU	Active	Inactive	No supply
Non-volatile SFRs (System Controller)	Active	Inactive; content not lost	Inactive; content not lost
Manchester/Biphase Coder, Timer	Software selectable	Software selectable	No supply
Peripheral modules: CRC, MLFSR	Software selectable	Inactive	No supply
Peripheral modules: I2C, SPI, ADC	Software selectable	Software selectable	No supply
Watchdog Timer	Active	Active	No supply
RAM Lower 128 byte	Active	Inactive; content not lost	Selectable power down (content lost) or inactive (content not lost)
RAM Upper 128 byte	Active	Inactive; content not lost	No supply; content lost
XData 16 byte	Active	Inactive; content not lost	Inactive; content not lost
FLASH memory	Active	Inactive; content not lost	No supply; content not lost
crystal oscillator	Software selectable	Software selectable	No supply
2 kHz RC oscillator	Active	Active	Active
12 MHz RC HF oscillator	Software selectable	Software selectable	Power down (Remark: automatically enabled after Carrier Detect WU)
Interval Timer	Active	Active	Active
LF Receiver	Software selectable	Software selectable	Software selectable
RF Transmitter	Software selectable	Software selectable	No supply
Vmin Detector	Software selectable	Software selectable	No supply

Note: Active: Block is powered, is active and keeps its register contents. Power consumption is high

Inactive: Block is powered, cannot be used, but keeps its register contents. Power consumption is low

No supply: Block is not powered, power consumption is very low.

2.2 System Controller

While the microcontroller controls PMA51xx in the RUN state, the System Controller takes over control in the POWER DOWN state and the IDLE state.

The System Controller handles the system clock, wake-up events, and system resets.

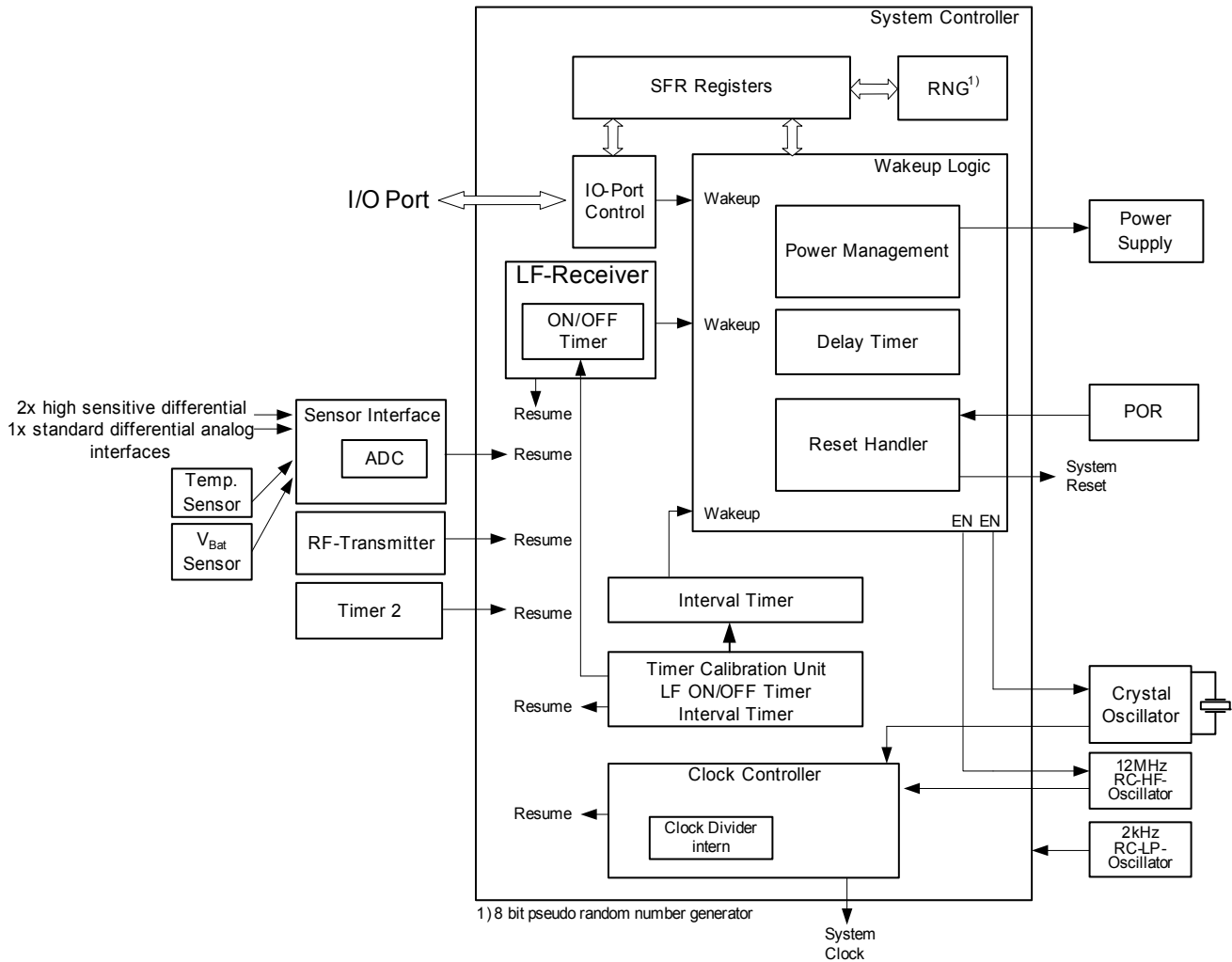

Figure 6 Block Diagram of the System Controller

2.2.1 Wake-up Logic

One of the key elements within the System Controller is the Wake-up Logic, which is responsible for transitions from the POWER DOWN state to the RUN state via the INIT state.

The difference between Reset and Wake-up

- **Reset** - Either via Software Reset, Brownout Reset, Power-On Reset or Reset pin, the digital circuit is reset. Program execution starts at address 0000_H to perform reset initialization routines (including operation mode selection), and will jump to the FLASH at address 4000_H in NORMAL mode to execute the application program.
- **Wake-up** - Only the microcontroller and its peripheral units are reset. Program execution starts at address 0000_H to perform wake-up initialization routines (for evaluating the wake-up source), and jumps to the FLASH at 4000_H to execute the application program.

Wake-up Event Handling

Whenever a wake-up event occurs, the PMA51xx leaves the POWER DOWN state and enters the RUN state to execute the application code. This transition can be initiated by various sources. The wake-up source can be identified by reading SFR WUF and SFR ExtWUF, which are cleared on read out. On every wake-up SFR bit DSR.1[WUP] is set to 1_B.

A wake-up source can be enabled or disabled by setting the appropriate bits in SFR WUM and SFR ExtWUM. For security reasons, the Interval Timer wake-up cannot be masked and the Interval Timer cannot be disabled in NORMAL mode.

The wake-up source (except the Watchdog Timer) is available during the whole RUN state. If an additional wake-up event occurs during the RUN state, the appropriate flag will be set, but the device won't be forced through INIT state.

Watchdog Timer Event

A Watchdog Timer event occurs after the Watchdog Timer has elapsed. The Watchdog Timer, which is only active in RUN and IDLE state cannot be masked.

See [Chapter 2.4.1](#) for details about the Watchdog Timer.

LF Receiver Wake-up Event

The LF Receiver wake-up can be enabled by setting one of these bits:

- SFR bit WUM.5 [LFCD] or
- SFR bit WUM.4 [LFSY] or
- SFR bit WUM.3 [LFPM1] and/or SFR bit WUM.2 [LFPM0]

The wake-up source can be read in the SFR WUF.

Note: The LF Receiver has to be configured appropriately for the particular wake-up modes. See [Chapter 2.10.4](#) for details.

External Wake-up Event

I/O Port PP1-PP4 and PP6-PP9 can be configured to wake up the PMA51xx from the POWER DOWN state by an external source.

Note: PP1-PP4 and PP6-PP9 have to be configured according to [Chapter 2.15.3](#) for this feature. The appropriate bits in SFR ExtWUF are only set when the PMA51xx leaves the POWER DOWN state. In RUN state and IDLE state these bits are not set.

Interval Timer Wake-up Event

When the Interval Timer elapses, a wake-up event is generated and the POWER DOWN state is left. The wake-up can be identified by the application software reading SFR bit WUF.0 [ITIM].

The Interval Timer is reloaded automatically with actual values from register ITPR and immediately restarted, so the Interval Timer is even working in the RUN state.

Note: The Interval Timer is not maskable in NORMAL mode, so the application will get Interval Timer wake-up events periodically. If these wake-up events occur during the RUN state, they will set the appropriate flag but not force the device through the INIT state.

IDLE state and Resume Event Handling

If switched to the IDLE state by setting SFR bit CFG0.5 [IDLE], the system clock to the microcontroller is gated off. This reduces the chip current consumption and simultaneously improves ADC resolution due to the lower noise level during the time that microcontroller is not clocked.

Note: The IDLE state will only be entered if one of the units providing a resume event is enabled and active. Otherwise, the system will continue executing code in the RUN state without entering the IDLE state.

Only few peripheral components are still active in the IDLE state. The Watchdog Timer is active and will be initialized automatically before entering the IDLE state; thus the IDLE state has a maximum duration of approx. 1 second before a Watchdog Timer wake-up occurs.

The system clock to the microcontroller is re-enabled when a resume event occurs.

The program code continues working where it was suspended. SFR bit CFG0.5 [IDLE] is automatically cleared after a resume event. The resume event source is available in SFR REF.

The IDLE state will be left in case an interrupt event occurs. After completion of the Interrupt service, the IDLE state will be re-entered in case no resume event is pending.

2.2.1.1 Register Description

Table 7 Registers Overview

Register Short Name	Register Long Name	Offset Address	Wakeup Value	Page Number
WUF	Wake-up Flag Register	C0 _H	XXXXXX0X _B	40
WUM	Wake-up Mask Register	C1 _H	UUUUUUUU _B	41
REF	Resume Event Flag Register	D1 _H	00 _H	39
ExtWUF	External Wake-up Flag Register	F1 _H	XXXXXXXX _B	37
ExtWUM	External Wake-up Mask Register	F2 _H	UUUUUUUU _B	38

External Wake-up Flag Register

ExtWUF	Offset	Wakeup Value	Reset Value
External Wake-up Flag Register	F1_H	XXXXXXXX_B	00_H

7	6	5	4	3	2	1	0
EXTWU7	EXTWU6	EXTWU5	EXTWU4	EXTWU3	EXTWU2	EXTWU1	EXTWU0
rc	rc	rc	rc	rc	rc	rc	rc

Field	Bits	Type	Description
EXTWU7	7	rc	External Wake-up event on PP9
EXTWU6	6	rc	External Wake-up event on PP8
EXTWU5	5	rc	External Wake-up event on PP7
EXTWU4	4	rc	External Wake-up event on PP6
EXTWU3	3	rc	External Wake-up event on PP4

Functional Description

Field	Bits	Type	Description
EXTWU2	2	rc	External Wake-up event on PP3
EXTWU1	1	rc	External Wake-up event on PP2
EXTWU0	0	rc	External Wake-up event on PP1

External Wake-up Mask Register

ExtWUM External Wake-up Mask Register		Offset F2 _H	Wakeup Value UUUUUUUU _B	Reset Value FF _H			
7	6	5	4	3	2	1	0
MEXTWU7	MEXTWU6	MEXTWU5	MEXTWU4	MEXTWU3	MEXTWU2	MEXTWU1	MEXTWU0
rw	rw	rw	rw	rw	rw	rw	rw

Field	Bits	Type	Description
MEXTWU7	7	rw	Mask External Wake-up 7 (on PP9) 0 _B External wake-up 7 allowed 1 _B External wake-up 7 disabled
MEXTWU6	6	rw	Mask External Wake-up 6 (on PP8) 0 _B External wake-up 6 allowed 1 _B External wake-up 6 disabled
MEXTWU5	5	rw	Mask External Wake-up 5 (on PP7) 0 _B External wake-up 5 allowed 1 _B External wake-up 5 disabled
MEXTWU4	4	rw	Mask External Wake-up 4 (on PP6) 0 _B External wake-up 4 allowed 1 _B External wake-up 4 disabled
MEXTWU3	3	rw	Mask External Wake-up 3 (on PP4) 0 _B External wake-up 3 allowed 1 _B External wake-up 3 disabled
MEXTWU2	2	rw	Mask External Wake-up 2 (on PP3) 0 _B External wake-up 2 allowed 1 _B External wake-up 2 disabled
MEXTWU1	1	rw	Mask External Wake-up 1 (on PP2) 0 _B External wake-up 1 allowed 1 _B External wake-up 1 disabled
MEXTWU0	0	rw	Mask External Wake-up 0 (on PP1) 0 _B External wake-up 0 allowed 1 _B External wake-up 0 disabled

Wake-up Flag Register

WUF		Offset	Wakeup Value	Reset Value			
Wake-up Flag Register		C0 _H	XXXXXX0X _B	00 _H			
7	6	5	4	3	2	1	0
WDOG	Res	LFCD	LFSY	LFPM1	LFPM0	Res	ITIM
rc		rc	rc	rc	rc		rc

Field	Bits	Type	Description
WDOG	7	rc	Watchdog Timer Event
Res	6		Reserved
LFCD	5	rc	LF RX carrier-detect Wake-up
LFSY	4	rc	LF RX sync-match Wake-up
LFPM1	3	rc	LF RX pattern 1-match Wake-up
LFPM0	2	rc	LF RX pattern 0-match Wake-up
Res	1		Reserved
ITIM	0	rc	Interval Timer Wake-up

Wake-up Mask Register

WUM
Wake-up Mask Register

Offset **Wakeup Value** **Reset Value**
C_{1H} **UUUUUUU_B** **FF_H**

7	6	5	4	3	2	1	0
MWDOG	Res	MLFCD	MLFSY	MLFPM1	MLFPM0	Res	MITIM
rw		rw	rw	rw	rw	r	rw

Field	Bits	Type	Description
MWDOG	7	rw	Mask Watchdog Timer This bit does only have effect in TEST -, DEBUG - and PROGRAMMING mode. 0 _B Watchdog Timer event allowed. Always allowed in NORMAL mode! 1 _B Watchdog Timer event disabled
Res	6		Reserved
MLFCD	5	rw	Mask LF RX carrier detected 0 _B LF RX carrier wake-up allowed 1 _B LF RX carrier wake-up disabled
MLFSY	4	rw	Mask LF RX sync match 0 _B LF RX sync match wake-up allowed 1 _B LF RX sync match wake-up disabled
MLFPM1	3	rw	Mask LF RX pattern 1 match 0 _B LF RX pattern 1 match wake-up allowed 1 _B LF RX pattern 1 match wake-up disabled
MLFPM0	2	rw	Mask LF RX pattern 0 match 0 _B LF RX pattern 0 match wake-up allowed 1 _B LF RX pattern 0 match wake-up disabled
Res	1	r	For future use
MITIM	0	rw	Mask Interval Timer Wake-up This bit does only have effect in TEST -, DEBUG - and PROGRAMMING mode. 0 _B Interval Timer wake-up allowed. Always allowed in NORMAL mode! 1 _B Interval Timer wake-up disabled

2.2.2 Interval Timer

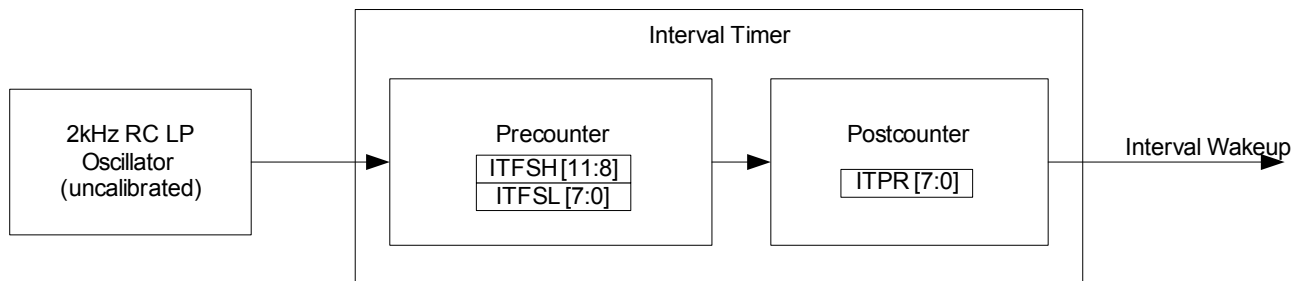

Figure 7 Interval Timer Block Diagram

The Interval Timer is responsible for waking up the PMA51xx from the POWER DOWN state after a predefined time interval. It is clocked by the 2 kHz RC LP oscillator and incorporates two dividers:

- Precounter: Can be calibrated to the system clock and represents the time base.
- Postcounter: Configures the Interval Timer duration. It can be set from 1-256_{dec}.

Timing accuracy can be ensured by using a Library function that calibrates the precounter with the accurate system clock (see [1]).

The Interval Timer duration is determined by the SFR ITPR. This value is calculated by using the following equation:

$$Interval\ Timer\ period[s] = \frac{precounter}{f_{2kHz\ RC\ LP\ Oscillator} \left[\frac{1}{s} \right]} \cdot postcounter$$

Figure 8 Calculation of Interval Timer period

The Postcounter (ITPR) is an 8-bit register. The maximum interval duration corresponds to 00_H (multiplication with 256_{dec}). 01_H up to FF_H corresponds to a multiplication with 1_{dec} up to 255_{dec}.

Note: After writing SFR ITPR, some clock cycles are needed to activate the new setting. SFR bit CFG1.1 [ITInit] is cleared automatically when the new setting is activated.

Interval Timer calibration

Due to the deviation of the 2 kHz RC LP oscillator frequency calibration is necessary and done by counting clock cycles from the crystal oscillator or the 12 MHz RC HF oscillator (depending on the current system clock) during one 2 kHz RC LP oscillator period. The counted clock cycles are used to calculate the appropriate configuration values. The calibration is performed automatically by a Library function (see [1]).

2.2.3 Register Description

Table 8 Registers Overview

Register Short Name	Register Long Name	Offset Address	Wakeup Value	Page Number
ITPL	Interval Timer Precounter Register Low Byte	BA _H	UUUUUUUU _B	44
ITPH	Interval Timer Precounter Register High Byte	BB _H	0000UUUU _B	43
ITPR	Interval Timer Period Register	BC _H	UUUUUUUU _B	44

Interval Timer Precounter Register High Byte

ITPH	Offset	Wakeup Value	Reset Value
Interval Timer Precounter Register High Byte	BB_H	0000UUUU_B	03_H

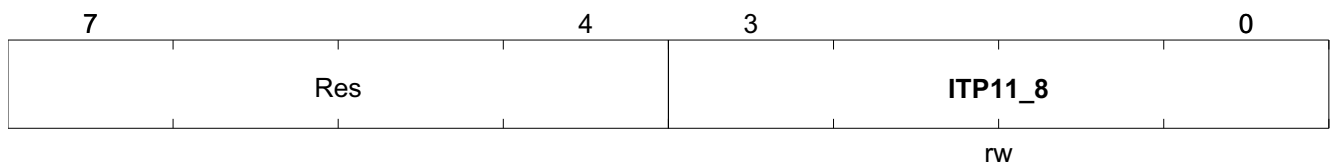

Field	Bits	Type	Description
Res	7:4		Reserved
ITP11_8	3:0	rw	Interval Timer Precounter Register bit 11 down to bit 8

Interval Timer Precounter Register Low Byte

ITPL	Offset	Wakeup Value	Reset Value
Interval Timer Precounter Register Low Byte	BA _H	UUUUUUUU _B	E8 _H

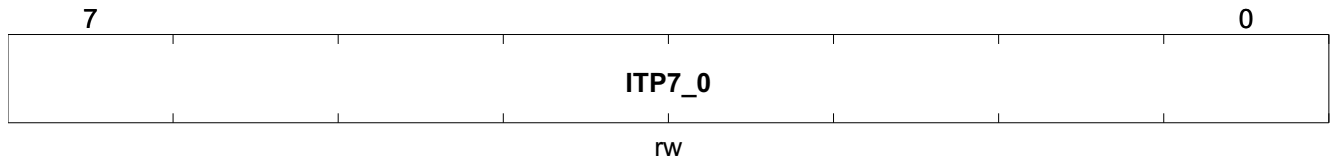

Field	Bits	Type	Description
ITP7_0	7:0	rw	Interval Timer Precounter Register bit 7 down to bit 0

Interval Timer Period Register

ITPR	Offset	Wakeup Value	Reset Value
Interval Timer Period Register	BC _H	UUUUUUUU _B	01 _H

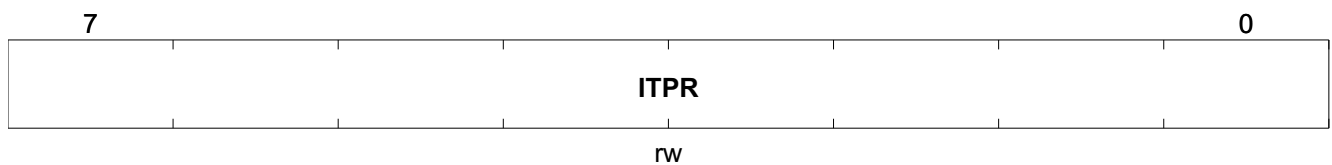

Field	Bits	Type	Description
ITPR	7:0	rw	Interval Timer Period Register

Note: These SFRs can be modified manually as well for using other (uncalibrated) precounter values. If the Interval Timer function is not needed for the application, it is recommended to set the registers ITPR, ITPL, ITPH to their maximal value of FF_H to save power. In this case, the wake-up interval will be extended to maximal interval.

2.3 System Configuration Registers

The system configuration registers are used for:

- Initiating state transitions
- System software reset
- Enabling or disabling peripherals
- Monitoring the operation mode, the system state, and peripherals

2.3.1 Register Description

Table 9 Registers Overview

Register Short Name	Register Long Name	Offset Address	Wakeup Value	Page Number
CFG2	Configuration Register 2	D8 _H	000U1000 _B	48
DSR	Diagnosis and Status Register	D9 _H	0XUU00XU _B	49
CFG1	Configuration Register 1	E8 _H	000U000U _B	47
CFG0	Configuration Register 0	F8 _H	0000U000 _B	46

Configuration Register 0

CFG0 Offset Wakeup Value Reset Value
 Configuration Register 0 F8_H 0000U000_B 00_H

7	6	5	4	1	0
PDWN	Res	IDLE		Res	CLKSel0
rw		rw			rw

Field	Bits	Type	Description
PDWN	7	rw	POWER DOWN state Enable POWER DOWN state is entered, if this bit is set to 1 _B . This bit is automatically reset to 0 _B by the system controller after wake-up from POWER DOWN state. 0 _B RUN state 1 _B POWER DOWN state
Res	6		Reserved Must be set to 0 _B .
IDLE	5	rw	IDLE state Enable IDLE state is entered, if this bit is set to 1 _B . This bit is automatically reset to 0 _B by the system controller after a resume event occurred. 0 _B RUN state 1 _B IDLE state
Res	4:1		Reserved
CLKSel0	0	rw	Clock Source Select 0 _B 12 MHz RC HF oscillator (internal) 1 _B Crystal oscillator is selected (external)

Configuration Register 1

CFG1 Offset Wakeup Value Reset Value
 Configuration Register 1 E8_H 000U000U_B 01_H

7	6	5	4	3	2	1	0
PMWEn	I2CEn	Res	RfTXPEn	ADCEn	SPIEn	ITInit	ITEn
rw	rw		rw	rw	rw	r	r

Field	Bits	Type	Description
PMWEn	7	rw	Program Memory Write Enable 0 _B Write access to Flash program memory not allowed 1 _B Write access to Flash program memory allowed Note: Write operation to program memory is not feasible on standard 8051 microcontroller, thus write access has to be allowed explicitly
I2CEn	6	rw	I2C Enable 0 _B I ² C-Interface disabled. Port Pins PP0 and PP1 are used as GPIOs 1 _B I ² C-Interface enabled. Port Pins PP0 and PP1 are used for I ² C communication
Res	5		Reserved
RfTXPEn	4	rw	RF TX Port Out Enable 0 _B PP2 is used as GPIO 1 _B PP2 is used for serial output of Manchester/BiPhase coded RF TX data
ADCEn	3	rw	ADC Enable 0 _B ADC disabled 1 _B ADC enabled
SPIEn	2	rw	SPI Enable 0 _B SPI-Interface disabled. Port Pins PP3 to PP6 are used as GPIOs 1 _B SPI-Interface enabled. Port pins PP3 to PP6 are used for SPI communication
ITInit	1	r	Interval Timer Initialization active 0 _B No reload 1 _B (Re)loads the Interval Timer with content of ITPR/ITPH/ITPL. This bit is automatically cleared after initialization completes
ITEn	0	r	Interval Timer Enable¹⁾ 0 _B Interval Timer is deactivated (not possible in NORMAL mode) 1 _B Enables Interval Timer countdown

1) Interval Timer is always enabled in NORMAL mode

Configuration Register 2

CFG2	Offset	Wakeup Value	Reset Value
Configuration Register 2	D8_H	000U1000_B	18_H

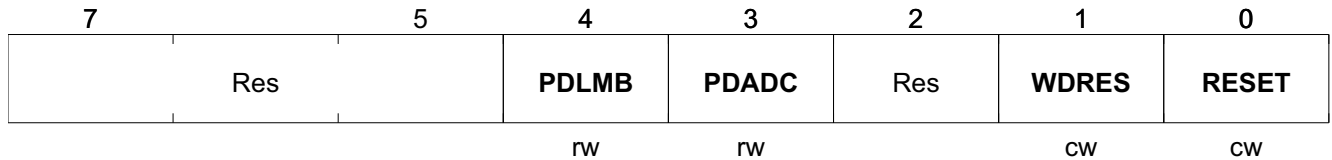

Field	Bits	Type	Description
Res	7:5		Reserved
PDLMB	4	rw	Power Down iRAM lower memory block 0 _B Contents of lower 128 byte of data memory (00 _H -7F _H) are kept active also in POWER DOWN state 1 _B Contents of lower 128 byte of data memory (00 _H -7F _H) are lost in POWER DOWN state
PDADC	3	rw	Power Down ADC 0 _B ADC analog circuit is supplied 1 _B ADC power down (ADC analog circuit not supplied)
Res	2		Reserved
WDRES	1	cw	Reset Watchdog Timer 0 _B Default 1 _B Watchdog Timer is reset and restarts counting from zero Note: WDRES is cleared automatically
RESET	0	cw	Reset System 0 _B Default 1 _B A software-assigned system reset is done. Note: Bit RESET is cleared automatically.

Diagnosis and Status Register

DSR	Offset	Wakeup Value	Reset Value
Diagnosis and Status Register	D9 _H	0XUU00XU _B	0XXX0000 _B

7	6	5	4	3	2	1	0
SCLK	Res	OpMODE		Res		WUP	FlashLCK
r		r		r		r	w

Field	Bits	Type	Description
SCLK	7	r	Currently selected system clock 0 _B 12 MHz RC HF oscillator clock selected 1 _B Crystal oscillator clock selected
Res	6		Reserved
OpMODE	5:4	r	Operation Mode Operation Mode applied at chip startup. 00 _B TEST mode 01 _B PROGRAMMING mode 10 _B DEBUG mode 11 _B NORMAL mode
Res	3:2	r	Reserved
WUP	1	r	Wake-up Pending This bit can be used for decision reset / wake-up. 0 _B No wake-up pending 1 _B Wake-up is pending (read detailed information from WUF/ExtWUF)
FlashLCK	0	w	FLASH Lock Is set to 1 _B by SW if Lockbyte 3 is set (D1 _H is detected at FLASH address 57FF _H). If Lockbyte 3 is set without setting Lockbyte 2, this byte has no effect and will result a unlocked FLASH. 0 _B Full FLASH access (FLASH related SFRs) 1 _B Restricted write access

2.4 Fault Protection

The PMA5110 features multiple fault protections that prevent the application from incurring unexpected behavior and deadlocks. This chapter gives a brief overview of the available fault protections.

2.4.1 Watchdog Timer

For operation security, a Watchdog Timer is available to avoid application deadlocks. The Watchdog Timer must be reset periodically by the microcontroller, otherwise the timer generates a reset and forces a restart of PMA5110 program execution. The SFRs which are not supplied in POWER DOWN state are initialized after a reset generated by the Watchdog Timer.

The Watchdog Timer is automatically reset by a Power On reset, Brown Out reset, xReset, software reset (CFG2.0[RESET]) or when the IDLE state is entered.

The Watchdog Timer duration is fixed to a nominal period of 1 s. The accuracy depends on the accuracy of the 2 kHz RC LP oscillator that is used to clock the Watchdog Timer.

Setting SFR bit CFG2.1 [WDRES] resets the Watchdog Timer (see [Configuration Register 0](#)). If a Watchdog Timer overflow occurred SFR bit WUF.7 [WDOG] is set to 1_B.

2.4.2 Vmin Detector

This circuit will detect if the supply voltage is below the minimum value required to guarantee correct chip operation. The Library functions that perform measurements will return the Vmin status in a status byte with the measurement result. The Vmin Detector can be used to either monitor the internal regulated supply voltage or the external supply voltage V_{Bat} . The selection of the supply voltage to monitor is done with bit LBD.3 [LBD2V1].

If enabled by LBD.1[LBDEn] and LBD.0[LBDMEn], the power supply voltage is sensed and bit LBD.2 [LBDF] is set to 1_B, if the supply voltage drops below threshold during measurement time.

2.4.2.1 Register Description

Low Battery Detector Control

LBD	Offset	Wakeup Value	Reset Value
Low Battery Detector Control	EF _H	0B _H	0B _H
7	4	3	2
1	0		
Res	LBD2V1	LBDF	LBDEn
	LBDMen		
	rw	rc	rw
			rw

Field	Bits	Type	Description
Res	7:4		Reserved

Functional Description

Field	Bits	Type	Description
LBD2V1	3	rw	Low Battery Voltage Switch 0 _B VDDD (internal voltage) 1 _B V _{Bat} (external voltage)
LBDF	2	rc	Low Battery Detector Flag 0 _B Supply voltage is higher then threshold voltage 1 _B Supply voltage is lower then threshold voltage
LBDEn	1	rw	Low Battery Detector enable 0 _B Low Battery Detector disabled 1 _B Low Battery Detector enabled
LBDMEn	0	rw	Low Battery Detector measurement enable <i>Note: LBDEn must be enabled at least 10us before LBDMEn can be set in order to start the measurement</i> 0 _B Stop measurement 1 _B Start measurement

2.4.3 Brownout Detector

The Brownout Detector resets the PMA when the supply voltage drops below VBRD in RUN state and below VPDBR in POWER DOWN state (see [Table 44 “Power On Reset” on Page 193](#)).

2.4.4 FLASH Memory Checksum

A CRC checksum is stored in the FLASH memory. After Lockbyte 2 is written, the CRC checksum can be recalculated and checked by the application program for verification of program code if needed.

If a single bit error in the FLASH memory occurs, it is corrected by the FLASH internal Error Correction Coder, as an indication the FCSP.7 [ECCErr] bit is set. (see [FLASH Control Register - Sector Protection Control on page 59](#))

2.4.5 ADC Measurement Overflow and Underflow

The Library functions that perform measurements will return the over/underflow status in a status byte with the measurement result.

2.5 Clock Controller

The Clock Controller for internal clock management is part of the System Controller.

The PMA51xx always starts up using the 12 MHz RC HF oscillator to provide minimum startup time and minimum current consumption. Changing the system clock from the 12 MHz RC HF oscillator to the crystal (e.g. for RF transmission) is performed automatically by calling a Library function (see [1]). If the crystal is selected as system clock, the 12 MHz RC HF oscillator is automatically powered down.

Note: Since the external crystal needs some startup time, a 3-bit delay timer is integrated to delay the clock switching. Depending on the crystal used, the SFR bits XTCFG.2-0 [XTDLY2-0] can be set to delay from typ. 0 μs up to 1750 μs in 250 μs steps (see XTAL Configuration Register).

The following figure shows which clocks are used for which PMA5110 blocks. Details about the individual blocks can be found in the appropriate chapters of this document

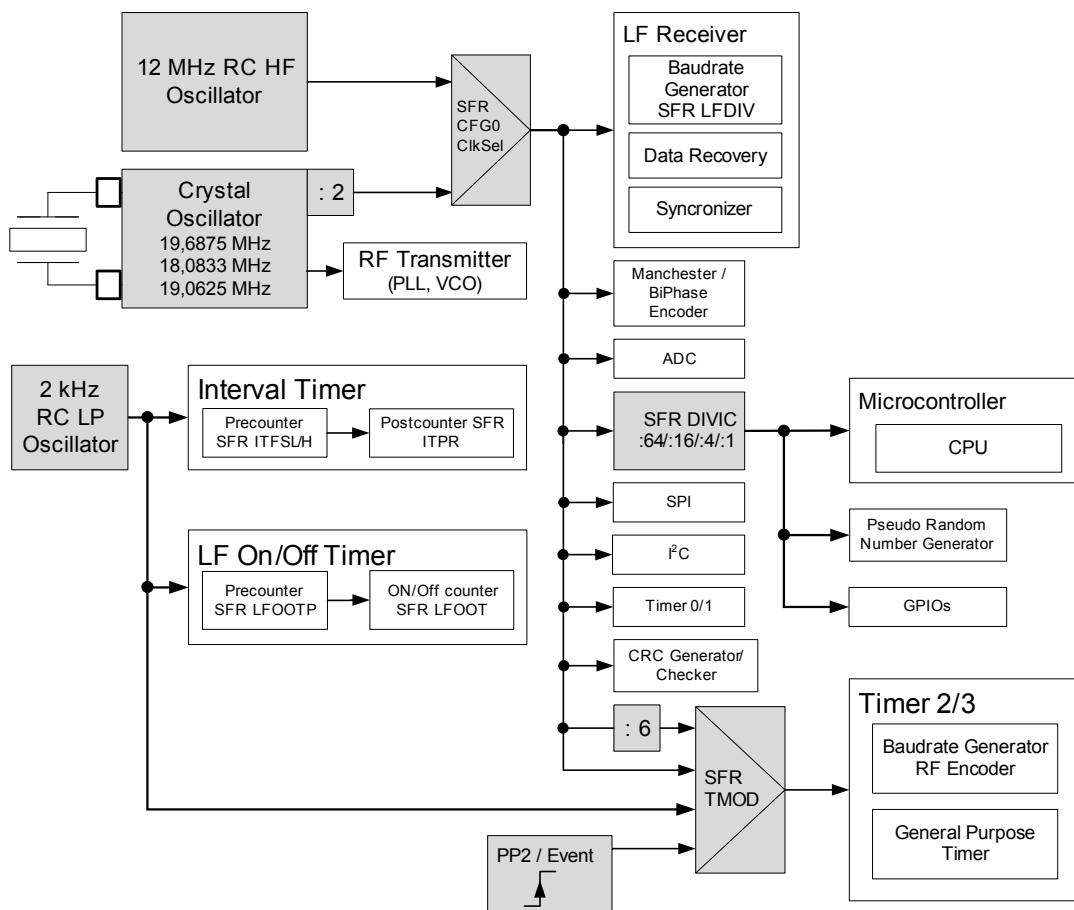

Figure 9 PMA5110 Clock Concept

2.5.1 Internal Clock Divider

To save power, it is possible to enable the internal clock divider to reduce the system clock by a prescaled factor. If SFR DIVIC is set to 00_H (default), the divider is disabled. For a description of the SFR DIVIC see [Internal Clock Divider on page 54](#).

2.5.2 2 kHz RC LP Oscillator (Low Power)

The 2 kHz RC LP oscillator stays always active.

2.5.3 12 MHz RC HF Oscillator (High Frequency)

The 12 MHz RC HF oscillator typically runs at 12 MHz. It is used as the default clock source for the PMA51xx in RUN state.

2.5.4 Crystal Oscillator

The nominal crystal operating frequencies are between 18 MHz and 20 MHz depending on the RF band used.

$$868 \text{ MHz} / 915 \text{ MHz} : f_{XTAL} [\text{Hz}] = f_{RF} [\text{Hz}] \cdot \frac{1}{48}$$

$$434 \text{ MHz} : f_{XTAL} [\text{Hz}] = f_{RF} [\text{Hz}] \cdot \frac{2}{48}$$

$$315 \text{ MHz} : f_{XTAL} [\text{Hz}] = f_{RF} [\text{Hz}] \cdot \frac{3}{48}$$

Figure 10 Formulas for Crystal selection dependent of RF Bands

Frequency pulling from the nominal crystal frequency is achieved by the internal capacitor banks. This is used for fine-tuning the ASK carrier frequency and the lower and upper modulation frequencies for FSK modulation. Thus, frequency differences due to crystals that are not exactly matched or differences in component tolerances can be trimmed device internal.

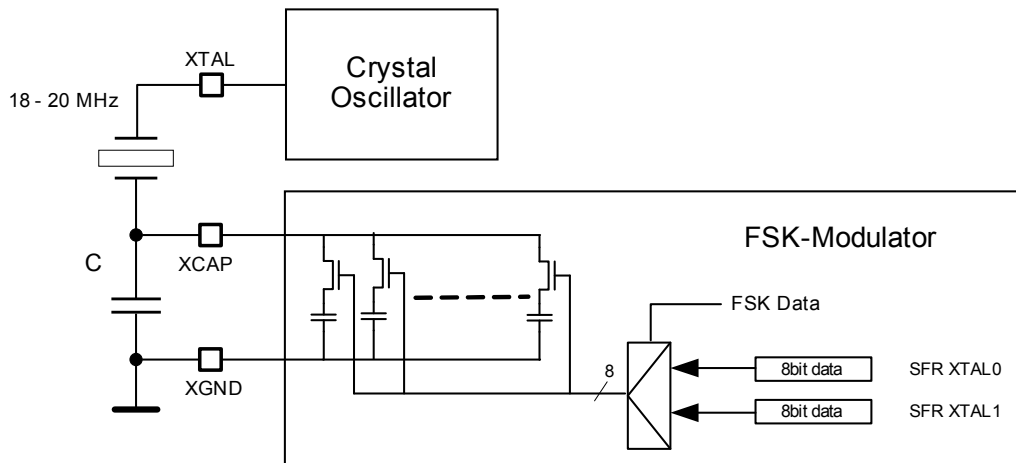

Figure 11 Crystal Oscillator and FSK-Modulator Block Diagram

Trimming of the Crystal Oscillator

The crystal oscillator can be trimmed using the internal capacitor array or externally. To use the internal capacitor array SFR bit RFTX.7 [XCapSH] has to be set to 0_B. The SFRs SFR XTAL0 and SFR XTAL1 allow the trimming of the crystal frequency in a broad range using the internal capacitor array. Setting SFR bit RFTX.7 [XCapSH] to 1_B shorts the internal capacitor array and the crystal oscillator can be trimmed externally.

2.5.5 Register Description

Table 10 Registers Overview

Register Short Name	Register Long Name	Offset Address	Wakeup Value	Page Number
DIVIC	Internal Clock Divider	B9 _H	000000UU _B	54
XTCFG	XTAL Configuration Register	C2 _H	00000UUU _B	56
XTAL1	XTAL Frequency Register FSKHIGH/ASK	C3 _H	UUUUUUUU _B	55
XTAL0	XTAL Frequency Register FSKLOW	C4 _H	UUUUUUUU _B	55

Internal Clock Divider



Field	Bits	Type	Description
Res	7:2		Reserved
DIVIC	1:0	rw	System Clock Divider Factor System clock, selected with CFG0.0[CLKSel0], is divided by 00 _B 1 01 _B 4 10 _B 16 11 _B 64

XTAL Frequency Register FSKLOW

XTAL0	Offset	Wakeup Value	Reset Value
XTAL Frequency Register FSKLOW	C4 _H	UUUUUUUU _B	FF _H

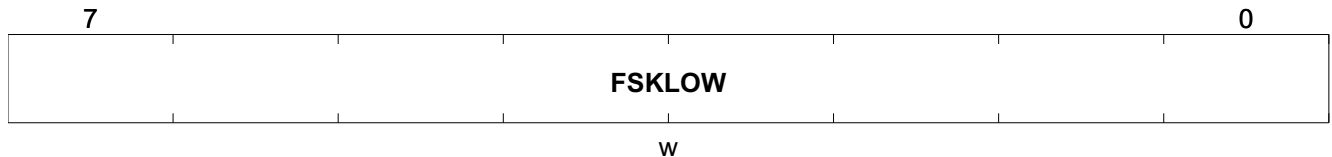

Field	Bits	Type	Description
FSKLOW	7:0	w	<p>FSK Low Frequency Capacitor select for lower FSK modulation frequency if RFENC.3[TXDD] = 0_B and RFTX.5[ASKFSK] = 0_B.</p> <p>The capacitor array is binary weighted from FSKLOW.7 = 20pF (MSB) down to FSKLOW.0 = 156fF (LSB)</p>

XTAL Frequency Register FSKHIGH/ASK

XTAL1	Offset	Wakeup Value	Reset Value
XTAL Frequency Register FSKHIGH/ASK	C3 _H	UUUUUUUU _B	FF _H



Field	Bits	Type	Description
FSKHASK	7:0	w	<p>FSK High Frequency Capacitor select for upper FSK modulation frequency if RFENC.3[TXDD] = 1_B and RFTX.5[ASKFSK] = 0_B</p> <p>ASK Center Frequency Capacitor select for ASK center frequency fine tuning if RFENC.3[TXDD] = 1_B and RFTX.5[ASKFSK] = 1_B</p> <p>The capacitor array is binary weighted from FSKHASK.7 = 20pF (MSB) down to FSKHASK.0 = 156fF (LSB)</p>

XTAL Configuration Register

XTCFG	Offset	Wakeup Value	Reset Value
XTAL Configuration Register	C2_H	0000UUU_B	03_H

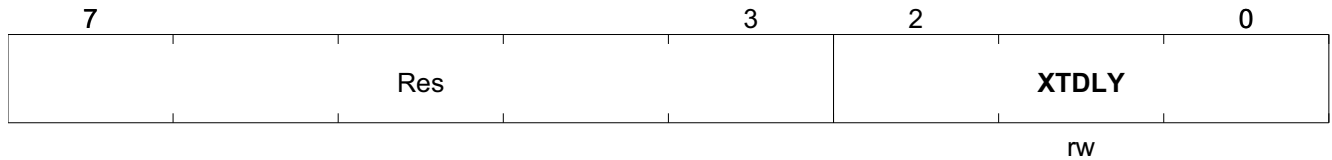

Field	Bits	Type	Description
Res	7:3		Reserved
XTDLY	2:0	rw	XTAL Startup Delay Time Delay time in steps of 250µs @ typ. 2 kHz RC LP oscillator clock = 2 kHz 000 _B typ. 0µs 001 _B typ. 250µs 010 _B typ. 500µs 011 _B typ. 750µs 100 _B typ. 1000µs 101 _B typ. 1250µs 110 _B typ. 1500µs 111 _B typ. 1750µs

2.6 Memory Organization

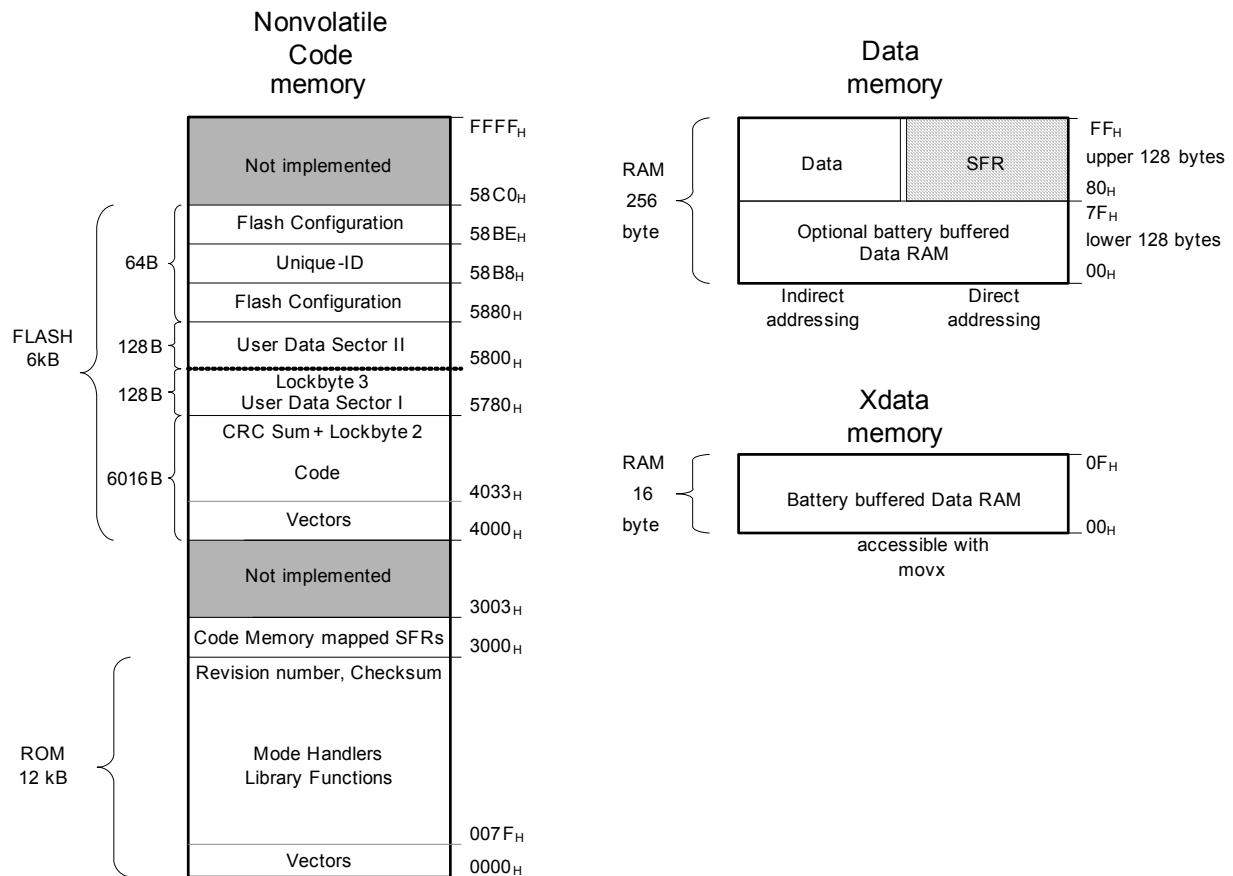

Figure 12 Memory Map

The Following Memory Blocks are implemented

- 12 kbyte ROM
- 6 kbyte FLASH code memory
- 2x128 byte User FLASH code/data memory
- 64 byte read-only FLASH configuration and unique-ID
- 2x128 byte data RAM, of which 128 bytes may be battery buffered
- 16 byte battery-buffered XData RAM

2.6.1 ROM

A 12 kbyte ROM is located in the address range 0000_H to 2FFF_H.

Function Library and Reset/Wake-up Handlers

The ROM contains the reset handler, the wake-up handler, and the Function Library (see [1]).

A hardware mechanism is implemented to prevent direct jumping into the ROM area. Access to the Library functions is granted via a vector table at the bottom of the ROM address space.

ROM protection

A hardware mechanism protects the ROM code against readout, so a read operation from the ROM in the protected address area returns zero.

2.6.2 FLASH

2.6.2.1 FLASH Organization

The FLASH is divided into four sectors. Each sector can be erased and written individually (byte wise erasing and writing is not possible).

- **4000_H -- 577F_H (6016 byte) code sector (sector 0):** This sector contains the code sector for the application program.
- **5780_H -- 587F_H (2x128 byte) User Data sector I + User Data sector II (sector 1 + sector 2):** These two sectors contain the user data sector, which can store individual device configuration data. The crystal frequency that is needed for the Library functions could also be saved here.
- **5880_H -- 58BF_H (64 byte) configuration sector (sector 3):** This sector contains the FLASH configuration sector for FLASH driver parameters and is write protected.

2.6.2.2 FLASH Protection

Write and erase operations on the FLASH code sector are only allowed in PROGRAMMING mode. To protect the FLASH against unauthorized access, three Lockbytes can be set:

- **Lockbyte 1:** This is written at the end of production test. The FLASH configuration sector is irreversibly switched to read-only.
- **Lockbyte 2:** Address 577F_H (Top address of the code sector).
This byte (as well as a ROM CRC) is optionally written by the programmer together with the code download. When the reset handler detects this byte, it sets the FCSP.1[CodeLCK]. When this bit is set, the DEBUG mode and PROGRAMMING mode are no longer accessible. Their pin settings lead to NORMAL mode wherein the CRC can be checked. This Lockbyte has to be set while programming the code sector to protect application code against undesired read-out.
- **Lockbyte 3:** Address 57FF_H (Top of User Data Sector I).
Lockbyte 3 can be set by the programmer during program download or by the application. After Lockbyte 3 has been set, a reset is necessary to get the User Data Sectors locked. Write accesses to the FLASH registers are blocked after Lockbyte 3 has been set.
If Lockbyte 3 is set without setting Lockbyte 2, this byte has no effect and will result in an unlocked FLASH. How to set Lockbyte 3 is described in [Chapter 2.18.6](#).

2.6.2.3 Register Description

FLASH Control Register - Sector Protection Control

FCSP
FLASH Control Register - Sector Protection Control

	Offset	Wakeup Value	Reset Value
	E9 _H	000000UU _B	00 _H



Field	Bits	Type	Description
ECCErr	7	rc	ECC Error Detected Bit 0 _B No Error Detected 1 _B Error Detected
Res	6:2		Reserved
CodeLCK	1	rw	Code Sector Lock Bit Is set to 1 _B by SW if Lockbyte 2 is set (D1 _H is detected at FLASH address 577F _H). 0 _B programmable & erasable 1 _B Read only
ConfLCK	0	rw	Config Sector Lock Bit Is set to 1 _B by SW if FLASH configuration sector has been locked (switched to read only). 0 _B programmable & erasable 1 _B Read only

2.6.3 RAM

The RAM is available as data storage for the application program. Library functions may use some RAM locations for passing parameters and internal calculations. The RAM area that is used for the Library functions is specified in [1].

The RAM is always powered in RUN state and IDLE state.

The upper 128 bytes of RAM are always switched off in POWER DOWN state and lose their contents in these states. SFR bit CFG2.4[PDLMB] determines if the lower 128 byte of RAM are powered during POWER DOWN state.

If not powered in these states, this RAM loses the content, otherwise it can be used as battery-buffered storage after a POWER DOWN period.

Note: The RAM is not reset during a System Reset. After a Brown Out Reset, this feature can be used to try to recover data from RAM.

After Power On Reset, the RAM is not initialized, and thus contains random data. The application has to initialize the RAM if needed.

2.6.4 Code Memory mapped SFRs

The code memory mapped SFRs can be used to implement an opcode which can be modified in runtime, for example to access SFRs or to implement variable jump addresses.

The registers MMR0, MMR1, and MMR2 - additionally mapped to address 3000_H - 3002_H may contain up to 3-byte opcode. Code address 3003_H contains a hard coded return statement (RET).

2.6.4.1 Register Description

Table 11 Registers Overview

Register Short Name	Register Long Name	Offset Address	Wakeup Value	Reset Value
MMR0	Memory Mapped Register 0	84 _H	00 _H	00 _H
MMR1	Memory Mapped Register 1	85 _H	00 _H	00 _H
MMR2	Memory Mapped Register 2	86 _H	00 _H	00 _H

2.6.5 Battery buffered data RAM

There are 16 bytes of battery buffered data RAM available that can be used by the application to store data during a POWER DOWN state period. This memory consumes relatively little leakage current compared to the whole lower memory block by storing small amount of data.

Note: The battery buffered data RAM is located in the xdata area and therefore not reset by a System Reset. After a Brownout Reset, this feature can be used to possibly recover data from RAM.

After a Power-On Reset, this memory is not initialized, and thus contain random data. The application has to initialize the battery buffered data RAM.

2.6.6 Special Function Registers

Special Function Registers (SFRs) are used to control and monitor the status of the PMA51xx and its peripherals. The following table shows the naming convention for the SFR descriptions that are used throughout this document.

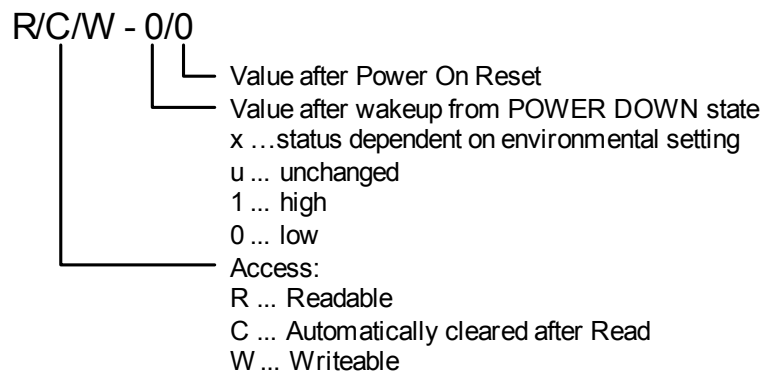

Figure 13 Naming Convention for Register Descriptions

Note: If a single bit or the whole byte value is declared as unchanged, it keeps its state even during POWER DOWN state.

Table 12 “Special Function Registers Overview” on Page 61 shows the power supply of each SFR and gives a reference to the page within this document where a detailed description can be found.

Table 12 Special Function Registers Overview

Register Short Name	Register Long Name	Register Address	Supplied in PDWN	Description
ACC	Accumulator	E0 _H	No	Page 65
ADCC0	ADC Configuration Register 0	DB _H	No	Page 116
ADCC1	ADC Configuration Register 1	DC _H	No	Page 118
ADCDL	ADC Result Register (low byte)	D4 _H	No	Page 119
ADCDH	ADC Result Register (high byte)	D5 _H	No	Page 119
ADCM	ADC Mode Register	D2 _H	No	Page 120
ADCOFF	ADC Input Offset c-network configuration	DA _H	No	Page 121
ADCS	ADC Status Register	D3 _H	No	Page 122
B	Register B	F0 _H	No	Page 65
CFG0	Configuration Register 0	F8 _H	Yes	Page 46

Table 12 Special Function Registers Overview

Register Short Name	Register Long Name	Register Address	Supplied in PDWN	Description
CFG1	Configuration Register 1	E8 _H	Yes	Page 47
CFG2	Configuration Register 2	D8 _H	Yes	Page 48
CRCC	CRC Control Register	A9 _H	No	Page 125
CRCD	CRC Data Register	AA _H	No	Page 126
CRC0	CRC Shift Register (low byte)	AC _H	No	Page 126
CRC1	CRC Shift Register (high byte)	AD _H	No	Page 127
DIVIC	Internal Clock Divider	B9 _H	Yes	Page 54
DPL	Data Pointer (low byte)	82 _H	No	Page 65
DPH	Data Pointer (high byte)	83 _H	No	Page 65
DSR	Diagnosis and Status Register	D9 _H	No	Page 49
ExtWUF	External Wake-up Flag Register	F1 _H	Yes	Page 37
ExtWUM	External Wake-up Mask Register	F2 _H	Yes	Page 38
FCSP	FLASH Control Register - Sector Protection Control	E9 _H	No	Page 59
I2CB	I ² C Baud rate Register	B1 _H	No	Page 160
I2CC	I ² C Control Register	A2 _H	No	Page 161
I2CD	I ² C Data Register	9A _H	No	Page 162
I2CM	I ² C Mode Register	A3 _H	No	Page 162
I2CS	I ² C Status Register	9B _H	No	Page 163
IE	Interrupt Enable Register	A8 _H	No	Page 69
IP	Interrupt Priority Register	B8 _H	No	Page 70
IRQRF	Interrupt Request Flag Register (for extended interrupts)	8F _H	No	Page 71
ITPL	Interval Timer Precounter Register (low byte)	BA _H	Yes	Page 44
ITPH	Interval Timer Precounter Register (high byte)	BB _H	Yes	Page 43
ITPR	Interval Timer Period Register	BC _H	Yes	Page 44
LBD	Low Battery Detector Control	EF _H	No	Page 50
LFCDFit	LF Carrier Detect Filtering	B2 _H	Yes	Page 94
LFCDM	LF Carrier Detector Mode	B5 _H	Yes	Page 95
LFDIV0	LF Division Factor (low byte)	B3 _H	Yes	Page 96
LFDIV1	LF Division Factor (high byte)	B4 _H	Yes	Page 96
LFOOT	LF On/Off Timer Configuration Register	C6 _H	Yes	Page 97
LFOOTP	LF On/Off Timer Precounter Register	C5 _H	Yes	Page 98
LFPCFG	LF Pattern Detection Configuration Register	C7 _H	Yes	Page 100

Table 12 Special Function Registers Overview

Register Short Name	Register Long Name	Register Address	Supplied in PDWN	Description
LFP0L	LF Pattern 0 Detector Sequence Data LSB	BE _H	Yes	Page 99
LFP0H	LF Pattern 0 Detector Sequence Data MSB	BF _H	Yes	Page 98
LFP1L	LF Pattern 1 Detector Sequence Data LSB	CE _H	Yes	Page 100
LFP1H	LF Pattern 1 Detector Sequence Data MSB	CF _H	Yes	Page 99
LFRX0	LF Receiver Configuration Register 0	B7 _H	Yes	Page 101
LFRX1	LF Receiver Configuration Register 1	B6 _H	Yes	Page 102
LFRXC	LF Receiver Control Register	F9 _H	Yes	Page 103
LFRXD	LF Receiver Data Register	A5 _H	Yes	Page 104
LFRXS	LF Receiver Status Register	A4 _H	Yes	Page 105
LFSYCNCFG	LF SYNC Matching Configuration Register	AF _H	Yes	Page 107
LFSYN0	LF Sync Pattern (low byte)	A6 _H	Yes	Page 106
LFSYN1	LF Sync Pattern (high byte)	A7 _H	Yes	Page 106
MMR0	Memory Mapped Register 0	84 _H	No	Page 60
MMR1	Memory Mapped Register 1	85 _H	No	Page 60
MMR2	Memory Mapped Register 2	86 _H	No	Page 60
P1DIR	IO-Port 1 Direction Register	91 _H	Yes	Page 150
P1IN	IO-Port 1 Data IN Register	92 _H	Yes	Page 152
P1OUT	IO-Port 1 Data OUT Register	90 _H	Yes	Page 153
P1SENS	IO-Port 1 Sensitivity Register	93 _H	Yes	Page 154
P3DIR	IO-Port 3 Direction Register	EB _H	Yes	Page 151
P3IN	IO-Port 3 Data IN Register	EC _H	Yes	Page 152
P3OUT	IO-Port 3 Data OUT Register	B0 _H	Yes	Page 153
P3SENS	IO-Port 3 Sensitivity Register	ED _H	Yes	Page 155
PSW	Program Status Word	D0 _H	No	Page 66
REF	Resume Event Flag Register	D1 _H	No	Page 39
RFC	RF Transmitter Control Register	EE _H	No	Page 77
RFD	RF Encoder Tx Data Register	8E _H	No	Page 77
RFENC	RF Encoder Tx Control Register	E7 _H	No	Page 78
RFFSPLL	RF Frequency Synthesizer PLL Configuration	D7 _H	No	Page 80
RFS	RF Encoder Tx Status Register	E6 _H	No	Page 81
RFFSLD	RF Frequency Synthesizer Lock Detector Configuration	DF _H	Yes	Page 79

Table 12 Special Function Registers Overview

Register Short Name	Register Long Name	Register Address	Supplied in PDWN	Description
RFTX	RF Transmitter Configuration Register	AE _H	Yes	Page 82
RFVCO	RF Frequency Synthesizer VCO Configuration	DE _H	Yes	Page 83
RNGD	RNG Data Register	AB _H	Yes	Page 128
SP	Stack Pointer	81 _H	No	Page 65
SPIB	SPI Baud rate Register (11 bit cascaded register)	F3 _H	No	Page 171
SPIC	SPI Control Register	F4 _H	No	Page 172
SPID	SPI Data Register	F5 _H	No	Page 173
SPIM	SPI Mode Register	F6 _H	No	Page 173
SPIS	SPI Status Register	F7 _H	No	Page 175
TCON	Timer Control Register (Timer 0/1)	88 _H	No	Page 132
TCON2	Timer Control Register 2 (Timer 2/3)	C8 _H	No	Page 143
TH0	Timer 0 Register (high byte)	8C _H	No	Page 133
TH1	Timer 1 Register (high byte)	8D _H	No	Page 133
TH2	Timer 2 Register (high byte)	CD _H	No	Page 144
TH3	Timer 3 Register (high byte)	CB _H	No	Page 144
TL0	Timer 0 Register (low byte)	8A _H	No	Page 134
TL1	Timer 1 Register (low byte)	8B _H	No	Page 134
TL2	Timer 2 Register (low byte)	CC _H	No	Page 145
TL3	Timer 3 Register (low byte)	CA _H	No	Page 145
TMOD	Timer Mode Register (Timer 0/1)	89 _H	No	Page 135
TMOD2	Timer Mode Register 2 (Timer 2/3)	C9 _H	No	Page 146
WUF	Wake-up Flag Register	C0 _H	Yes	Page 40
WUM	Wake-up Mask Register	C1 _H	Yes	Page 41
XTAL0	XTAL Frequency Register (FSKLOW)	C4 _H	Yes	Page 55
XTAL1	XTAL Frequency Register (FSKHIGH/ASK)	C3 _H	Yes	Page 55
XTCFG	XTAL Configuration Register	C2 _H	Yes	Page 56

2.7 Microcontroller

Central part of the PMA51xx is an 8051 instruction set compatible microcontroller. The CPU offers an 8 bit data path, an interrupt controller, several addressing modes (direct, register, register indirect, bit direct), and accesses peripheral components using Special Function Registers (SFR). The architecture of the CPU is well known and not part of this description. However some of the features are not needed or adapted to special product requirements. These features are described herein in detail.

The CPU incorporates basic core internal registers. Accumulator (ACC), Register B (B) and Program Status Word (PSW) are bit addressable registers used to perform arithmetical and logical operations. Stack Pointer (SP) and Data Pointer (DPL/DPH) are included to allow basic programming structures.

2.7.1 Register Description

Table 13 Registers Overview

Register Short Name	Register Long Name	Offset Address	Wakeup Value	Reset Value
SP	Stack Pointer	81 _H	07 _H	07 _H
DPL	Data Pointer (low byte)	82 _H	00 _H	00 _H
DPH	Data Pointer (high byte)	83 _H	00 _H	00 _H
PSW	Program Status Word	D0 _H	00 _H	00 _H
ACC	Accumulator	E0 _H	00 _H	00 _H
B	Register B	F0 _H	00 _H	00 _H

Program Status Word

SFR PSW holds the result of basic arithmetic operations.

PSW	Offset		Wakeup Value		Reset Value			
Program Status Word	D0 _H		00 _H		00 _H			
	7	6	5	4	3	2	1	0
	CY	AC	F0	RS1	RS0	OV	F1	P
	rw	rw	rw	rw	rw	rw	rw	r

Field	Bits	Type	Description
CY	7	rw	Carry Bit Set to 1 _B if ACC changes signed number range through 00 _H /FF _H (unsigned range overflow).
AC	6	rw	Auxiliary Carry Bit Carry-out for BCD operations.
F0	5	rw	General Purpose Bit 0 May be freely used by software.
RS1	4	rw	Register Select Bit 1 Register bank select bit 1.
RS0	3	rw	Register Select Bit 0 Register bank select bit 2.
OV	2	rw	Overflow Bit Set to 1 _B if ACC changes signed number range through 80 _H /7F _H with arithmetic operations (signed range overflow).
F1	1	rw	General Purpose Bit 1 May be freely used by software.
P	0	r	Parity Bit Reflects the number of 1s in the ACC (set to 1 _B if ACC contains an odd number of 1s)

2.8 Interrupt Sources

As in the integrated CPU, the rest of PMA5110 supports interrupt events from several sources which are listed in [Table 14](#).

When an unmasked interrupt occurs, the Program Counter (PC) is automatically set to the vector assigned to the interrupt source. From there, the vector is forwarded via LJMP instruction into the FLASH area and the offset of 4000_H is added.

When an unmasked interrupt occurs while the device is in IDLE state, this state is immediately left and the PC continues operation on the appropriate interrupt vector. After the processing of the Interrupt Service Routine (ISR) (RETI instruction), the device automatically returns to the IDLE state in case no Resume Event has occurred in between. If a Resume Event has been detected during the ISR, the RETI instruction returns the PC to the location after the Idle instruction. It is highly recommended that this instruction to be a NOP.

The priority of the interrupts can be configured using the IP register. Setting a bit in IP to one assigns higher priority to the linked interrupt. A high-priority interrupt can then interrupt a service routine from a low-priority interrupt.

Table 14 Interrupt Vector Locations

Interrupt Vector	Vector Address	Forwarded Address	Interrupt Source
Reset Vector	00 _H	4000 _H	
Vector 0	03 _H	4003 _H	External Interrupt 0 (PP9)
Vector 1	0B _H	400B _H	Timer 0 Interrupt
Vector 2	13 _H	4013 _H	External Interrupt 1 (PP7)
Vector 3	1B _H	401B _H	Timer 1 Interrupt
Vector 4	23 _H	4023 _H	I ² C Interface Interrupt
Vector 5	2B _H	402B _H	SPI Interface Interrupt
Vector 6	33 _H	4033 _H	Extended Interrupt: The FLASH software has to detect the interrupt source peripheral from this Vector by reading IRQFR and the appropriate source within the peripheral from the various flag registers. <ul style="list-style-type: none"> • Timer 2 Interrupt • Timer 3 Interrupt • LF Receiver Interrupt • RF Encoder Interrupt

2.8.1 External Interrupts 0 and 1

The PMA51xx has two external interrupt sources, Ext_Int0 on PP9 and Ext_Int1 on PP7. According to the 8051 standard implementation, the control bits and interrupt flags can be found in the TCON register (please refer to [Timer Control Register Timer 0/1 on page 132](#)).

When enabled by setting IE.0 [EX0] for External Interrupt 0 (resp. IE.2 [EX1] for External Interrupt 1), interrupts can be generated from PP9 (resp. PP7).

External Interrupts 0 and 1 can be programmed to be level-activated or negative-transition activated by clearing or setting bit TCON.0 [IT0], respectively TCON.2 [IT1]. If bit ITx=0, the corresponding external interrupt is triggered by a detected low-level at the pin. If ITx=1, the corresponding external interrupt is negative edge-triggered. In this mode, if successive samples of the pin show a high in one cycle and a low in the next cycle, interrupt request flag IEx in TCON is set. Flag bit IEx=1 then requests the interrupt.

If the external interrupt is level-activated, the external source has to hold the request active until the requested interrupt is actually generated. Then it has to deactivate the request before the ISR is completed, or else another interrupt will be generated.

Each of the external interrupts has its own interrupt vector.

2.8.2 Timer Interrupts

All four timers on the PMA51xx can be used as interrupt sources.

While Timer 0 and Timer 1 are fully compatible with the original 8051 CPU (for a description please refer to "Timer/Counter interrupts" on Page 76), Timer 2 and Timer 3 interrupts are treated as extended interrupts.

2.8.3 I²C Interface Interrupts

The data transfer on the I²C interface can be controlled via interrupts. This module has a separate interrupt vector (vector address 4023_H) where the PC is automatically set whenever one of the I²C interrupt flags is active and the interrupt source is unmasked.

2.8.4 SPI Interface Interrupts

The data transfer on the SPI interface can be controlled via interrupts. This module has a separate interrupt vector (vector address 402B_H) where the PC is automatically set whenever one of the SPI interrupt flags is active and the interrupt source is unmasked.

2.8.5 LF Receiver Interrupts

While one feature of the LF Receiver is to wake up the device, it is also possible to receive data via the LF interface in RUN mode by selecting the 12 MHz RC oscillator as the system clock. The wake-up flags are used as interrupt event flags, and wake-up mask bits are used as interrupt mask bits as well.

Interrupt Flags

- WUF.5 [LFCD]: Carrier detected
- WUF.4 [LFSY]: Sync match detected
- WUF.3 [LFPM1]: Pattern match pattern 1
- WUF.2 [LFPM0]: Pattern match pattern 0

Interrupt Mask bits

- WUM.5 [LFCD]: If set to 1 the carrier detector interrupt is masked (disabled)
- WUM.4 [LFSY]: If set to 1 the sync match interrupt is masked (disabled)
- WUM.3 [LFPM1]: If set to 1 the pattern match interrupt for pattern 1 is masked (disabled)
- WUM.2 [LFPM0]: If set to 1 the pattern match interrupt for pattern 0 is masked (disabled)

In addition the extended interrupt sources have to be enabled by setting IE.6 [EID] to 1.

2.8.6 RF Encoder Interrupts

The CPU should be kept in the IDLE state during RF transmission, this leads to a better emission spectrum. Nevertheless, it is possible to coordinate the data transfer interrupt driven. Therefore, two interrupt sources are available for RF transmission:

RF Encoder interrupt source flags:

- RFS.0 [RFBF] RF Encoder Buffer Full
- RFS.1 [RFSE] RF Encoder Shift Register Empty

2.8.7 Register Description

Table 15 Registers Overview

Register Short Name	Register Long Name	Offset Address	Wakeup Value	Page Number
IRQFR	Interrupt Request Flag Register for extended interrupts	8F _H	00 _H	71
IE	Interrupt Enable Register	A8 _H	00 _H	69
IP	Interrupt Priority Register	B8 _H	00 _H	70

Interrupt Enable Register

IE								Offset	Wakeup Value	Reset Value
Interrupt Enable Register								A8 _H	00 _H	00 _H
7	6	5	4	3	2	1	0			
EA	EID	ESPI	EI2C	ET1	EX1	ET0	EX0			
rw	rw	rw	rw	rw	rw	rw	rw			

Field	Bits	Type	Description
EA	7	rw	Global interrupt enable 0 _B All interrupts are disabled 1 _B Interrupts enabled according to their enable bits
EID	6	rw	Enable extended interrupts Timer 2/3, LF Receiver, RF Encoder 0 _B Interrupts disabled 1 _B Interrupts enabled according to their enable bits
ESPI	5	rw	Enable interrupts from SPI 0 _B Interrupts disabled 1 _B Interrupts enabled
EI2C	4	rw	Enable interrupts from I2C 0 _B Interrupts disabled 1 _B Interrupts enabled according to their enable bits
ET1	3	rw	Enable interrupts from Timer 1 0 _B Interrupts disabled 1 _B Interrupts enabled according to their enable bits
EX1	2	rw	Enable external interrupts from PP7 0 _B Interrupts disabled 1 _B Interrupts enabled

Functional Description

Field	Bits	Type	Description
ET0	1	rw	Enable interrupts from Timer 0 0 _B Interrupts disabled 1 _B Interrupts enabled according to their enable bits
EX0	0	rw	Enable external interrupts from PP9 0 _B Interrupts disabled 1 _B Interrupts enabled

Interrupt Priority Register

IP	Offset	Wakeup Value	Reset Value					
Interrupt Priority Register	B8 _H	00 _H	00 _H					
	7	6	5	4	3	2	1	0
Res	PID	PSPI	PI2C	PT1	PX1	PT0	PX0	
	rw	rw	rw	rw	rw	rw	rw	rw

Field	Bits	Type	Description
Res	7		Reserved
PID	6	rw	Priority level for extended interrupts Timer 2/3, LF Receiver, RF Encoder 0 _B Low priority 1 _B High priority
PSPI	5	rw	Priority level for SPI interrupts 0 _B Low priority 1 _B High priority
PI2C	4	rw	Priority level for I2C interrupts 0 _B Low priority 1 _B High priority
PT1	3	rw	Priority level for Timer 1 interrupts 0 _B Low priority 1 _B High priority
PX1	2	rw	Priority level for external interrupts from PP7 0 _B Low priority 1 _B High priority
PT0	1	rw	Priority level for Timer 0 interrupts 0 _B Low priority 1 _B High priority

Functional Description

Field	Bits	Type	Description
PX0	0	rw	Priority level for external interrupts from PP9 0 _B Low priority 1 _B High priority

Interrupt Request Flag Register for extended interrupts

IRQFR	Offset	Wakeup Value	Reset Value
Interrupt Request Flag Register for extended interrupts	8F _H	00 _H	00 _H

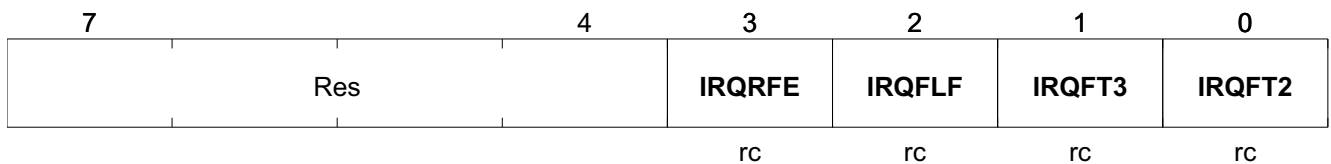

Field	Bits	Type	Description
Res	7:4		Reserved
IRQRFE	3	rc	Interrupt Request Flag RF Encoder 0 _B No interrupt occurred or flag cleared by readout 1 _B RF Encoder interrupt occurred
IRQFLF	2	rc	Interrupt Request Flag LF Receiver 0 _B No interrupt occurred or flag cleared by readout 1 _B LF Receiver interrupt occurred
IRQFT3	1	rc	Interrupt Request Flag Timer 3 0 _B No interrupt occurred or flag cleared by readout 1 _B Timer 3 interrupt occurred
IRQFT2	0	rc	Interrupt Request Flag Timer 2 0 _B No interrupt occurred or flag cleared by readout 1 _B Timer 2 interrupt occurred

2.9 RF Transmitter

The RF Transmitter consists of a PLL Frequency Synthesizer that is contained fully on chip, a Lock Detector, and a Power Amplifier.

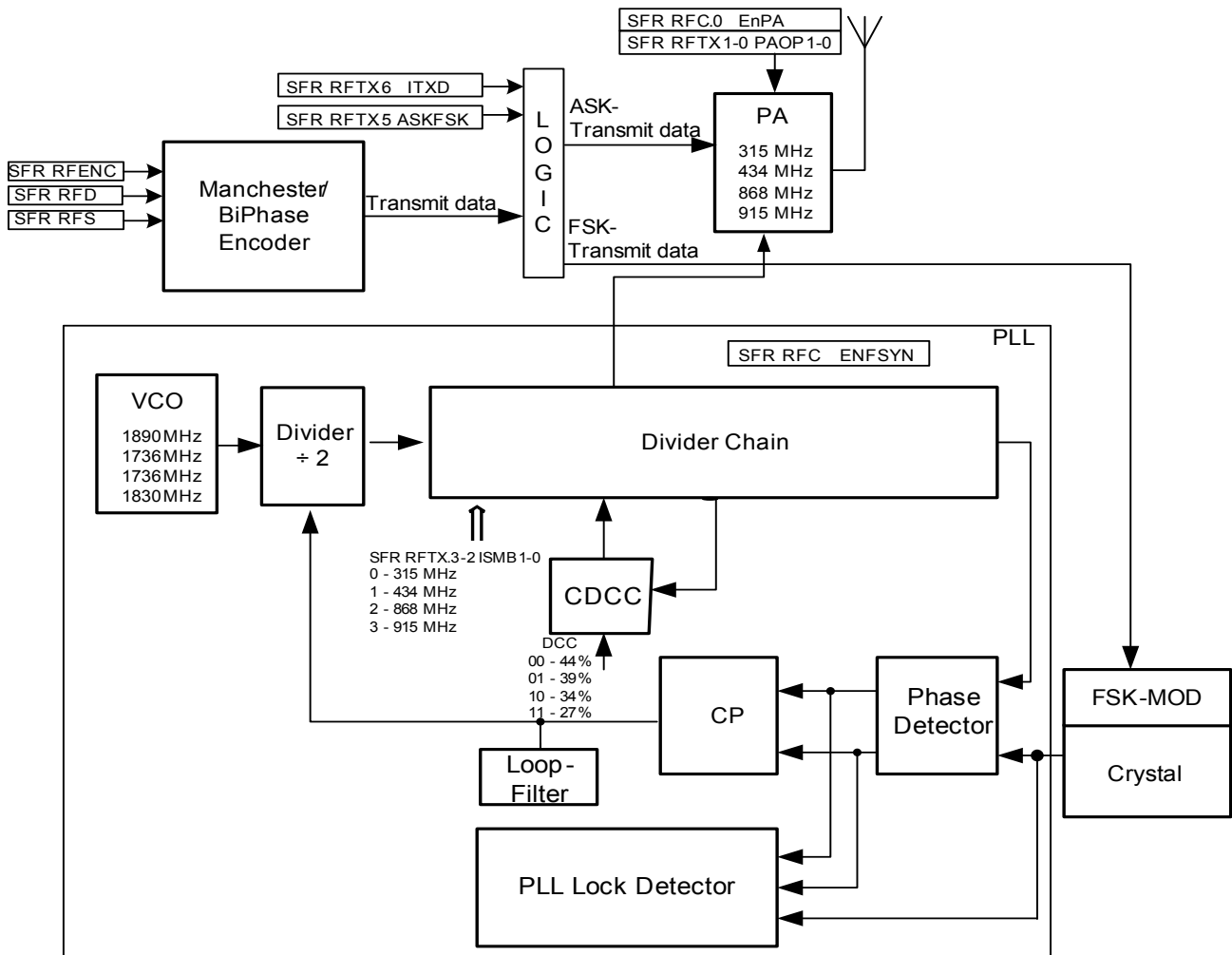

Figure 14 RF Transmitter Block Diagram

The RF Transmitter can be configured for the 315/434/868/915 MHz ISM-Band frequencies by setting SFR bits RFTX.3-2 [ISMB1-0] and choosing the proper crystal. Manchester/BiPhase/NRZ coded data with a bit rate up to 32 kbit/s (64 kchips/s) for the temperature range -40°C to +85°C and 20 kbit/s (40 kchips/s) for temperatures above +85°C can be transmitted using ASK or FSK modulation.

The PLL Synthesizer and the Power Amplifier can be enabled separately by using the SFR RFC control register. The Power Amplifier should be switched on with a delay of at least 100 µs after enabling the Frequency Synthesizer. This delay is needed for PLL locking.

2.9.1 Phase-Locked Loop (PLL)

The PLL consists of an on-chip VCO, an asynchronous divider chain with selectable overall division ratio, a phase detector with charge pump, and an internal loop filter. (see [RF Frequency Synthesizer PLL Configuration on page 80](#))

The PLL can be enabled manually by setting SFR bit RFC.1 [ENFSYN]. The PLL lock frequency is determined by the crystal used (see [Figure 10 “Formulas for Crystal selection dependent of RF Bands” on Page 53](#)) and the appropriate configuration in the SFR bits RFTX.3-2 [ISMB1-0].

2.9.2 Voltage-Controlled Oscillator (VCO)

16 frequency tuning curves are available to tune the VCO. The Library Function *VCOTuning()* can be used to select the appropriate tuning curve for the VCO depending on environmental conditions (temperature, V_{Bat}) and to enable the PLL (please refer to [\[1\]](#)).

Selection of the tuning curve can also be done using RRVCO.3-0 [VCOF3-0]. This is done automatically by the Reset Handler after power up or a system reset by using the PLL Lock Detector and the PLL lock-detection routine. Additionally, the PLL Lock Detector for VCO tuning curve selection may be used by the user program code before RF data transmission.

Note: Recalibration of the tuning curve is typically necessary when the supply voltage changes by more than 800 mV or the temperature changes by more than 70 degrees.

2.9.3 Power Amplifier (PA)

The highly efficient Power Amplifier is enabled automatically if a byte is transmitted (RFS.1 [RFSE] is set to 0_B). Alternatively, the Power Amplifier is enabled immediately by using RFC.0 [ENPA]. RFENC.3 [TXDD] is used to define the quiescent state (symbol that is sent when no data is available in RFD). The nominal transmit power levels are +5/8/10 dBm into a 50 Ω load at a supply voltage of 3.0 V. The Power Amplifier operating point must be optimized to the output power +5/8/10 dBm regarding current consumption by properly setting the RFTX.1-0 [PAOP1-0], RFFSPLL.3-2 [DCC1-0] and using an optimal-sized matching circuit. The Power Amplifier should be enabled at least 100 μs after enabling the RF Frequency Synthesizer because of the PLL lock-in time.

2.9.4 ASK Modulator

ASK modulation is done by turning on and off the Power Amplifier, depending on the baseband data to be transmitted (On/Off-Keying) by using RFENC.3 [TXDD] or the Manchester/Biphase Encoder (see also [Manchester/BiPhase Encoder with Bit Rate Generator](#)). For information about FSK modulation, please see [Crystal Oscillator](#).

2.9.5 Manchester/BiPhase Encoder with Bit Rate Generator

A Manchester/BiPhase encoder controlled by the CPU is available as source for the RF Transmitter. The encoding bit rate can be set with Timer 3 (see [Chapter 2.14.2.3](#)). The application software needs to configure the timer and can subsequently send the raw uncoded data to the Manchester/BiPhase Encoder which takes care about encoding and the RF transmission itself (controlling the Power Amplifier). Using the hardware encoder allows the CPU to be operated at a reduced clock rate thereby reducing the peak current consumption during RF transmission. The reduced CPU clock rate also reduces the possibility of clock noise artifacts in the RF signal (see [Chapter 2.5.1](#)). Furthermore, the encoder creates a resume event after sending each byte therefore the application can enter IDLE state while sending each databyte (see [Chapter 2.1.2.3](#)). It is recommended to use both reduced clock rate and IDLE mode for best performance during RF transmission. A library function is available for comfortable configuration of the Manchester/BiPhase Encoder.

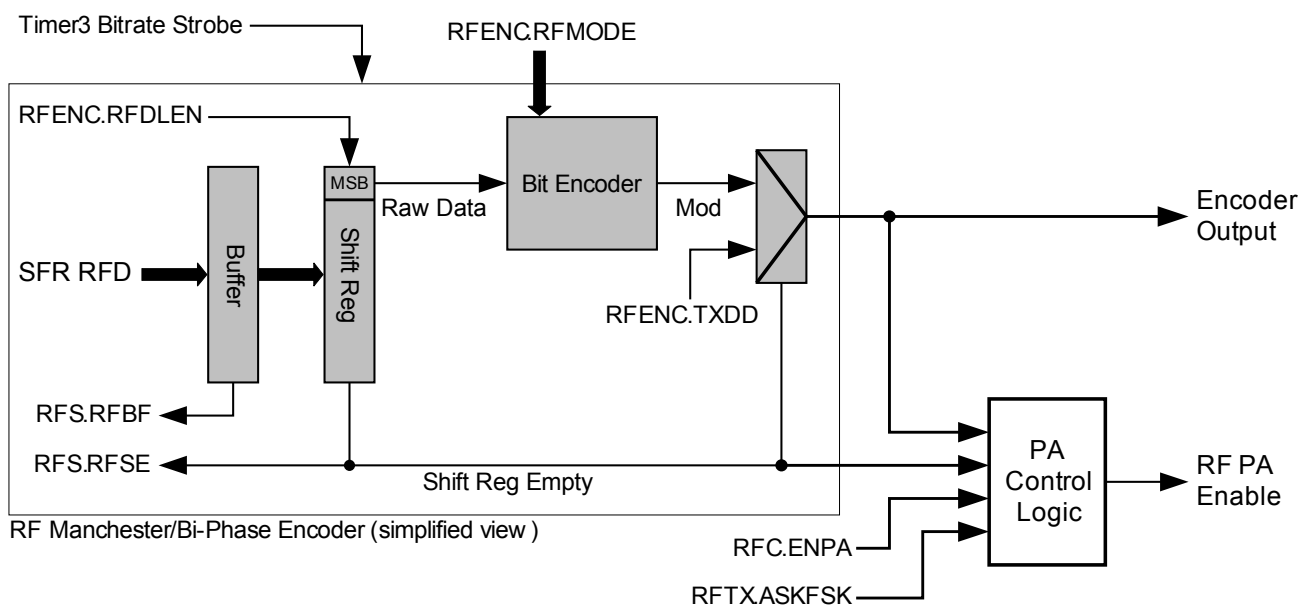

Figure 15 Manchester/BiPhase Encoder

For a transmission using Manchester, BiPhase or Chip coding data is written to SFR RFD. The Manchester/BiPhase Encoder automatically enables the Power Amplifier when a new data byte is written to SFR RFD and disables the Power Amplifier after transmitting the last data bit automatically as well.

The encoding selection can be changed every time before a data byte is written to the SFR RFD by adjusting SFR bits RFENC.2-0 [RFMode2-0].

The Chip coding mode (SFR bits RFENC.2-0 [RFMode2-0] = 101b) can be used to send data with a user-defined encoding scheme, e.g. for sending a preamble. The Chip mode sends each bit without encoding, but at twice the data rate.

For full flexibility in terms of timing and protocol the RF PA can be controlled without using the Bit Encoder. If the shift register is empty, the data value defined by SFR bit RFENC.3 [TXDD] is assigned to the Encoder Output after the RF PA has been enabled by setting SFR bit RFC.1 [ENFSYN] and SFR bit RFC.0 [EnPA]. If any byte is written into SFR RFD the Bit Encoder takes over control of the RF PA until the last bit has been transmitted and the shift register is empty again.

The RF Encoder Output can be connected to PP2, if enabled via CFG1.4[RfTXPEn]. When this alternate port functionality is enabled, the SFR bit RFC.1 [ENFSYN] and SFR bit RFC.0 [EnPA] must be set in order to allow the RF Encoder output to properly modulate the RF PA.

Note: The Power Amplifier should be switched on using SFR bit RFC.0 [EnPA] with a delay of at least 100 μs after enabling the Frequency Synthesizer using SFR bit RFC.1 [ENFSYN]. This delay is needed for PLL locking.

The following figure shows the different timing diagrams for the various encoding schemes:

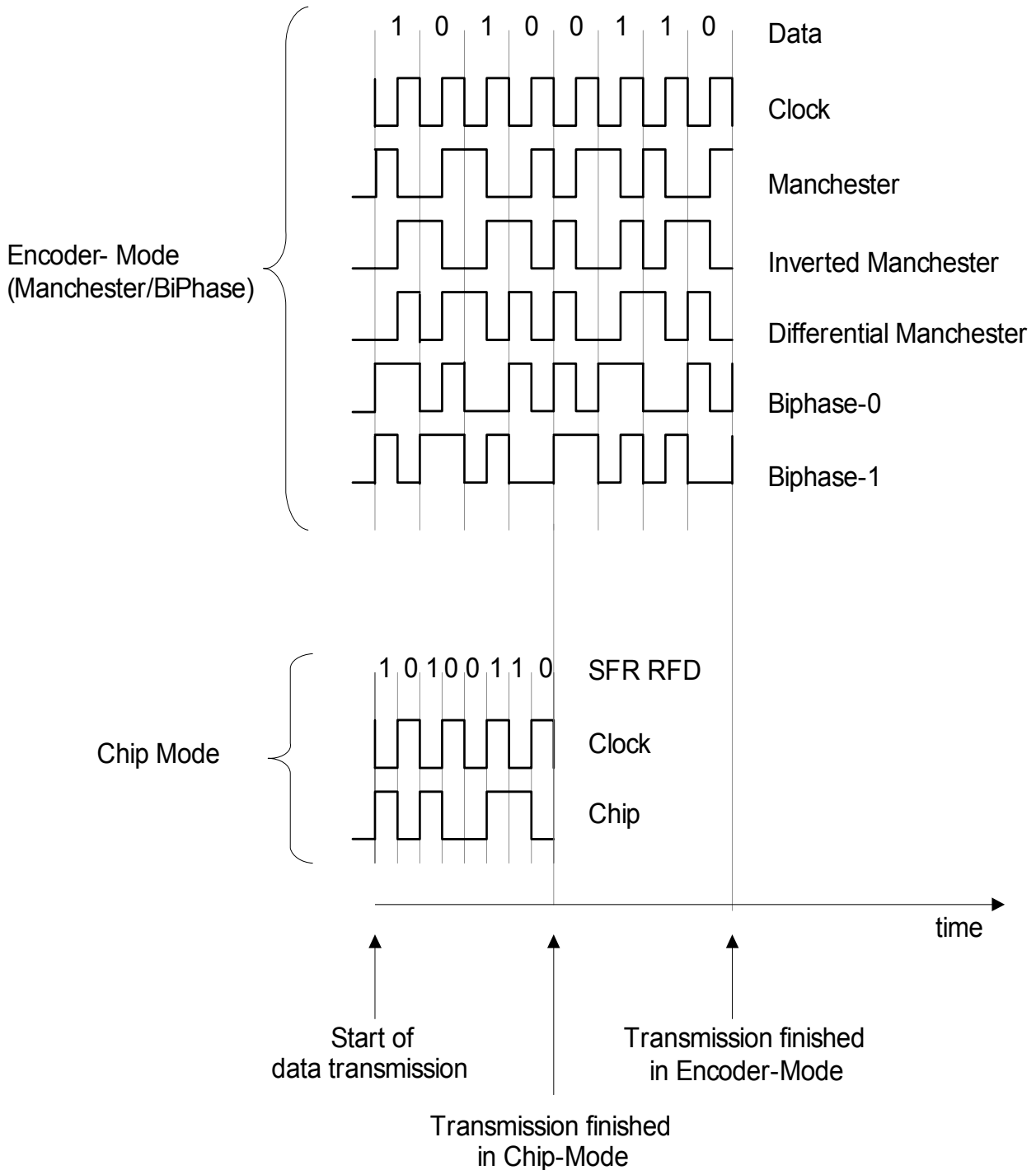

Figure 16 Diagram of the Different RF Encoder Modes

Timer 3 (see [Chapter 2.14.2.3](#)) provides the bit rate clock and has to be set according to the desired bit rate. The bit rate timer value can be calculated with the following formula:

$$Timer\ value = \frac{f_{Timer\ clock\ source} [Hz]}{8 \cdot Bitrate \left[\frac{1}{s} \right]} - 1$$

Figure 17 Calculation of RF bit rate timer value

Timer 3 has to be configured properly using timer registers (see Registers [TL2](#), [TH2](#), [TL3](#), [TH3](#), [TMOD2](#), [TCON2](#)). The SFR RFS represents the status of the RF Encoder.

After writing a data byte to SFR RFD, the SFR bit RFS.0 [RFBF] is set. It is cleared automatically when the data byte in SFR RFD is transferred to the shift register.

The application should poll SFR bit RFS.0 [RFBF] to determine when the data is transferred to the shift register and SFR RFD can take the next data byte for processing.

It is necessary to provide the transmitter with a continuous data stream. If no data is available, the transmitter falls back to quiescent state (see SFR bit RFENC.3 [TXDD]), if the Power Amplifier has been enabled by SFR bit RFC.1 [ENFSYN] and SFR bit RFC.0 [EnPA], otherwise the Power Amplifier is turned off automatically.

SFR bit RFS.1 [RFSE] is set when the last data bit has been transmitted. If this bit is set, the Power Amplifier and the PLL can be disabled. If there are any data in the shift register this bit is cleared.

2.9.6 Register Description

Table 16 Registers Overview

Register Short Name	Register Long Name	Offset Address	Wakeup Value	Page Number
RFD	RF Encoder TX Data Register	8E _H	00 _H	77
RFTX	RF Transmitter Configuration Register	AE _H	UUUUUUUU _B	82
RFFSPLL	RF Frequency Synthesizer PLL Configuration	D7 _H	82 _H	80
RFVCO	RF Frequency Synthesizer VCO Configuration	DE _H	UUUUUUUU _B	83
RFFSLD	RF Frequency Synthesizer Lock Detector Configuration	DF _H	000UUUUU _B	79
RFS	RF Encoder Tx Status Register	E6 _H	02 _H	81
RFENC	RF Encoder Tx Control Register	E7 _H	E0 _H	78
RFC	RF Transmitter Control Register	EE _H	00 _H	77

RF Transmitter Control Register

RFC	Offset	Wakeup Value	Reset Value
RF Transmitter Control Register	EE_H	00_H	00_H

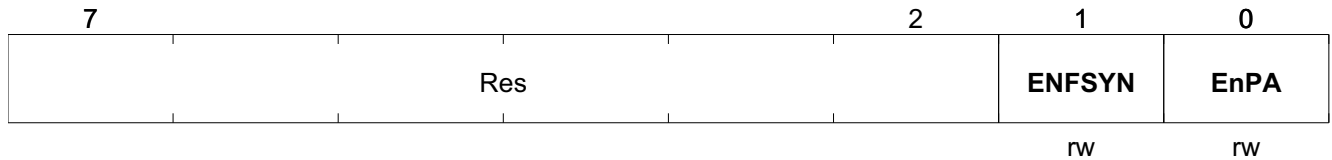

Field	Bits	Type	Description
Res	7:2		Reserved
ENFSYN	1	rw	Enable RF Frequency Synthesizer 0 _B RF Frequency Synthesizer disabled 1 _B RF Frequency Synthesizer enabled
EnPA	0	rw	Enable RF Power Amplifier 0 _B RF Power Amplifier disabled 1 _B RF Power Amplifier enabled

RF Encoder TX Data Register

By writing a data byte to the SFR RFD, the data transmission is invoked automatically. By default, the transmission takes place byte-aligned. If fewer than 8 bits are to be transmitted, SFR bits RFENC.7-5 [RFDLen2-0] can be set to determine the number of bits that should be transmitted with MSB first. In this case the unused LSBs are disregarded.

RFD	Offset	Wakeup Value	Reset Value
RF Encoder TX Data Register	8E_H	00_H	00_H

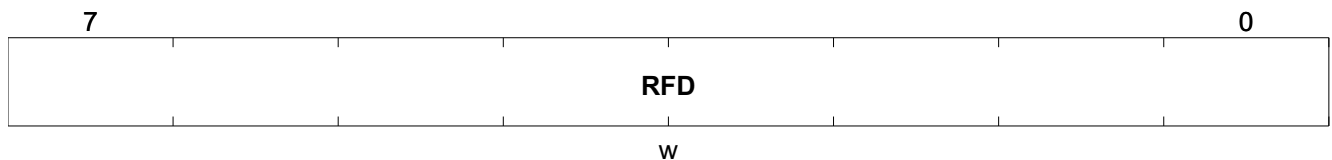

Field	Bits	Type	Description
RFD	7:0	w	RF Encoder TX Data Register

RF Encoder Tx Control Register

RFENC	Offset	Wakeup Value	Reset Value
RF Encoder Tx Control Register	E7_H	E0_H	E0_H

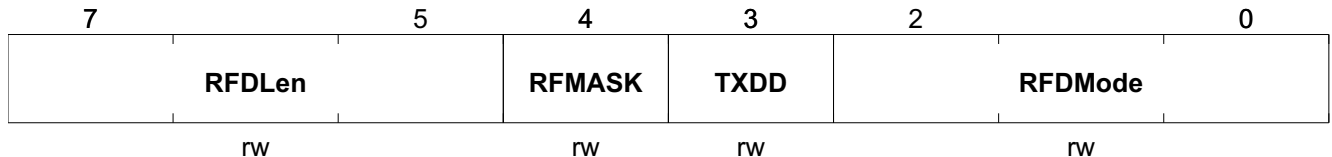

Field	Bits	Type	Description
RFDLen	7:5	rw	RF Data Length Number of bits to be transmitted from SFR RFD with MSB first. If fewer than 8 bits are transmitted, the unused LSBs are disregarded. 000 _B 1 bit 001 _B 2 bits 010 _B 3 bits 011 _B 4 bits 100 _B 5 bits 101 _B 6 bits 110 _B 7 bits 111 _B 8 bits
RFMASK	4	rw	RF Interrupt Mask Flag 0 _B Interrupt enabled 1 _B Interrupt disabled (masked)
TXDD	3	rw	Transmit data If SFR bit RFC.1-0 [ENFSYN-EnPA] is set. Defines quiescent state on RF TX. Symbol that is sent when no data is available in RFD. 0 _B RF TX transmits symbol for 0 _B 1 _B RF TX transmits symbol for 1 _B
RFDMode	2:0	rw	RF Encoder Mode A diagram of the different RF Encoder Modes can be found in Figure 16 . 000 _B Manchester 001 _B Inverted Manchester 010 _B Differential Manchester 011 _B BiPhase-0 100 _B BiPhase-1 101 _B Chips: Data bits are interpreted as chips 110 _B Reserved 111 _B Reserved

RF Frequency Synthesizer Lock Detector Configuration

RFFSLD	Offset	Wakeup Value	Reset Value
RF Frequency Synthesizer Lock Detector Configuration	DF_H	000UUUU_B	08_H

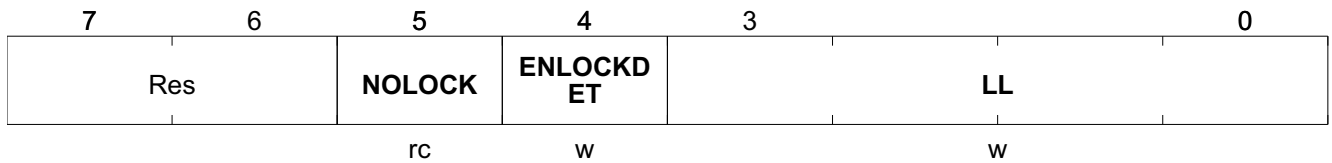

Field	Bits	Type	Description
Res	7:6		Reserved
NOLOCK	5	rc	PLL Lock Indicator 0 _B PLL has locked or bit cleared by read out 1 _B PLL has not locked while ENLOCKDET=1 _B
ENLOCKDET	4	w	Enable Lock Detector 0 _B Lock Detector disabled 1 _B Lock Detector enabled
LL	3:0	w	Lock Limit Selection Sets the number of phase synchronization violation. LL3-0 count value is reset to zero when the ENLOCKDET bit is reset. 0000 _B First violation will trigger NOLOCK 0001 _B Second violation will trigger NOLOCK ... 1110 _B 15 th violation will trigger NOLOCK 1111 _B 16 th violation will trigger NOLOCK

RF Frequency Synthesizer PLL Configuration

RFFSPLL Offset Wakeup Value Reset Value
RF Frequency Synthesizer PLL D7_H 82_H 82_H
Configuration

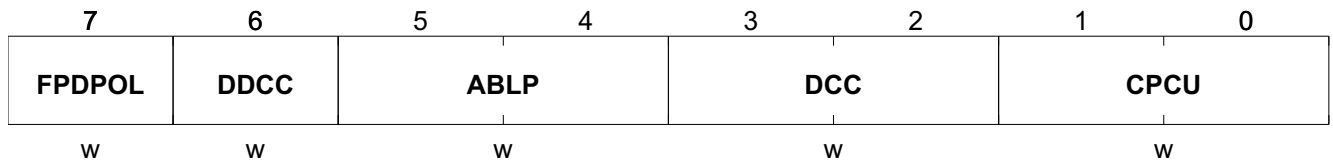

Field	Bits	Type	Description
FPDPOL	7	w	Frequency-Phase-Detector polarity Must be 1 _B
DDCC	6	w	Disable RF divider duty cycle control 0 _B RF divider duty cycle control enabled 1 _B RF divider duty cycle control disabled
ABLP	5:4	w	Antibacklash pulse width selection 00 _D 1.2ns (default value, do not change)
DCC	3:2	w	RF divider duty cycle control (high/low ratio) The RF divider duty cycle control can be used to increase the Power Amplifier output power at low supply voltages. 00 _B 44% 01 _B 39% 10 _B 34% 11 _B 27%
CPCU	1:0	w	Charge pump current selection 10 _B 20μA (default value, do not change)

RF Encoder Tx Status Register

RFS	Offset	Wakeup Value	Reset Value
RF Encoder Tx Status Register	E6 _H	02 _H	02 _H

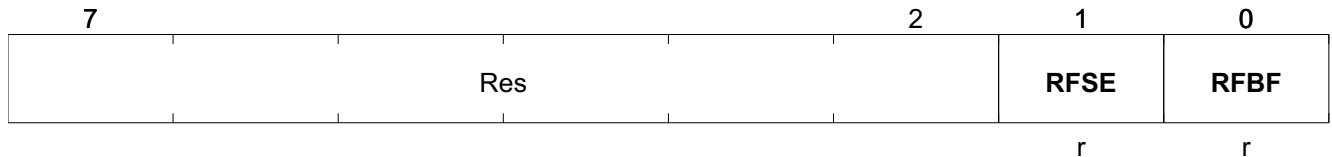

Field	Bits	Type	Description
Res	7:2		Reserved
RFSE	1	r	<p>RF Encoder Shift Register Empty</p> <p>This bit is automatically set by hardware if no further bits are available in the shift register.</p> <p>0_B RF Encoder shift register is not empty 1_B RF Encoder shift register is empty</p>
RFBF	0	r	<p>RF Encoder Buffer Full</p> <p>This bit is automatically set by hardware on write access to register RFD or cleared if data in register RFD is transferred to shift register respectively.</p> <p>0_B RF Encoder buffer empty 1_B RF Encoder buffer full</p>

RF Transmitter Configuration Register

RFTX Offset Wakeup Value Reset Value
RF Transmitter Configuration Register AE_H UUUUUUUU_B 07_H

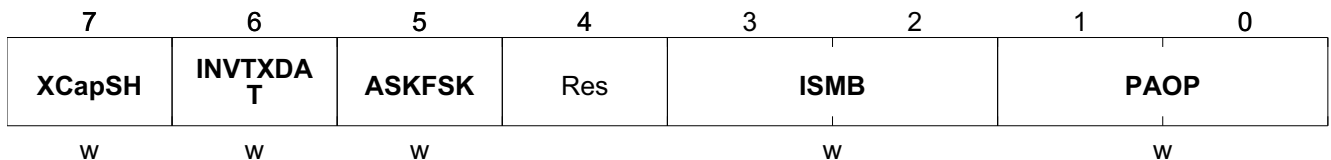

Field	Bits	Type	Description
XCapSH	7	w	Enable XCAP short More information about this bit can be found in Chapter 2.5.4 . 0 _B XCAP short disabled 1 _B XCAP short enabled
INVTXDAT	6	w	Invert TX Data 0 _B TX data not inverted 1 _B TX data inverted
ASKFSK	5	w	TX Mode 0 _B FSK 1 _B ASK
Res	4		Reserved
ISMB	3:2	w	RF Frequency Select ISMB 00 _B 315MHz frequency range 01 _B 434MHz frequency range 10 _B 868MHz frequency range 11 _B 915MHz frequency range
PAOP	1:0	w	RF Power Amplifier Output Power Selection 00 _B 5dBm 01 _B 8dBm 10 _B 8dBm 11 _B 10dBm

RF Frequency Synthesizer VCO Configuration

RFVCO	Offset	Wakeup Value	Reset Value
RF Frequency Synthesizer VCO Configuration	DE _H	UUUUUUUU _B	90 _H

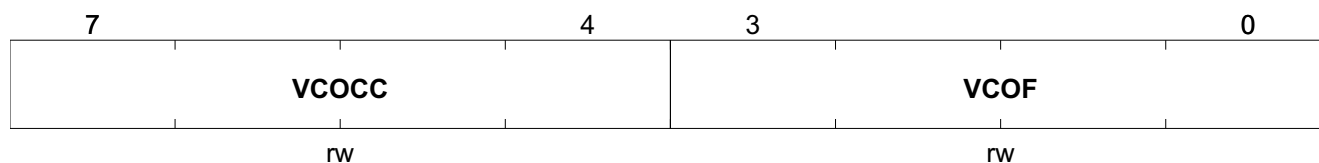

Field	Bits	Type	Description
VCOCC	7:4	rw	VCO Core Current Selection 0000 _B 0µA 0001 _B 200µA 0010 _B 400µA 0011 _B 600µA 0100 _B 800µA 0101 _B 1000µA 0110 _B 1200µA 0111 _B 1400µA 1000 _B 1600µA 1001 _B 1800µA 1010 _B 2000µA 1011 _B 2200µA 1100 _B 2400µA 1101 _B 2600µA 1110 _B 2800µA 1111 _B 3000µA
VCOF	3:0	rw	VCO Tuning Curve Selection 0000 _B Tuning Curve 0 0001 _B Tuning Curve 0 ... 1110 _B Tuning Curve 14 1111 _B Tuning Curve 15

2.10 LF Receiver

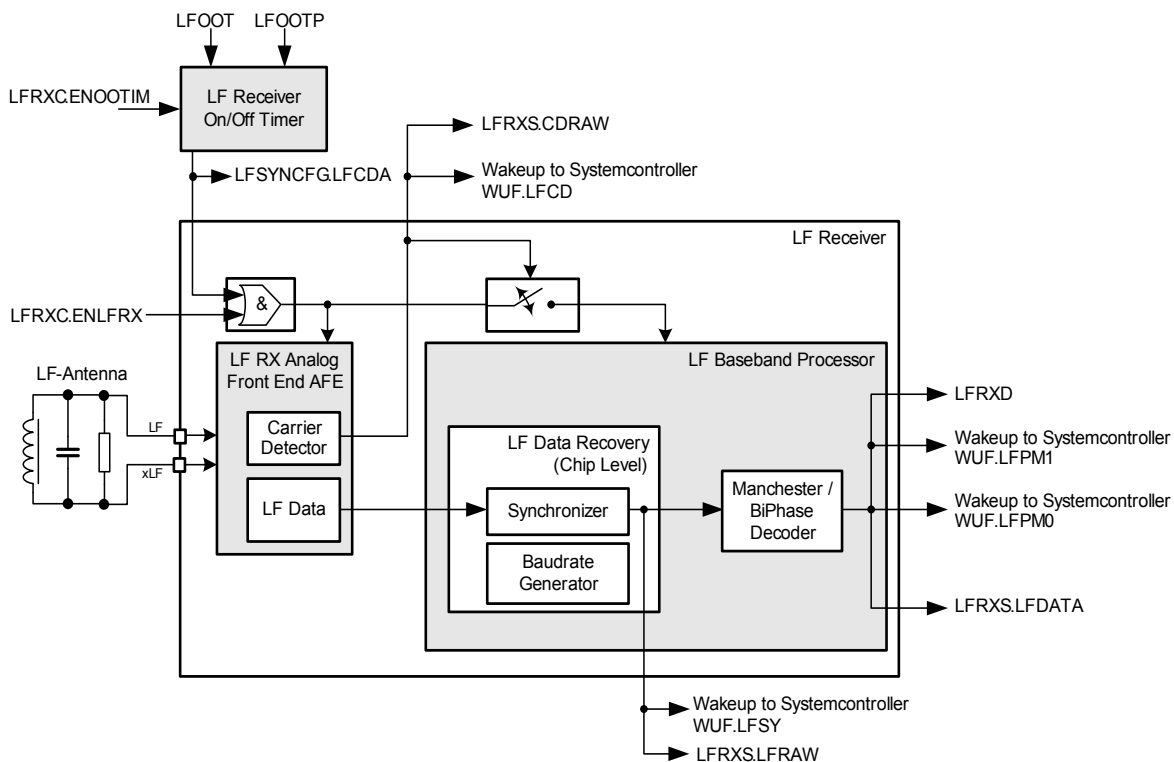

Figure 18 LF Receiver

The LF Receiver is used for wireless data transmission towards the PMA5110 and for waking up the device from POWER DOWN state.

It can generate a wake-up directly by the Carrier Detector if the carrier amplitude is above a preset threshold, or it can decode the received data and not wake up the microcontroller until a predefined sync match pattern or wake-up pattern is detected in the data stream.

Data recovery using a synchronizer and a decoder is available for Manchester and BiPhase coded data. The synchronizer can also handle Manchester/BiPhase code violations. Any other coding scheme can be handled directly by the microcontroller on the chip level without using the decoder.

An LF On/Off Timer is implemented to generate periodic on/off switching of the LF Receiver in the POWER DOWN state. This can be done to reduce the current consumption.

2.10.1 LF Receiver Analog Front End Configuration

The LF Receiver Analog Front End (AFE) consists of an input attenuator with an Automatic Gain Control (AGC), an amplifier with selectable gain, an ASK demodulator, a Data Filter and Data Slicer with adjustable filter bandwidth for different data rate. Additionally, a Carrier Detector with adjustable threshold is implemented. A LF Carrier Detector Filter can be enabled to avoid wake-up by interferers.

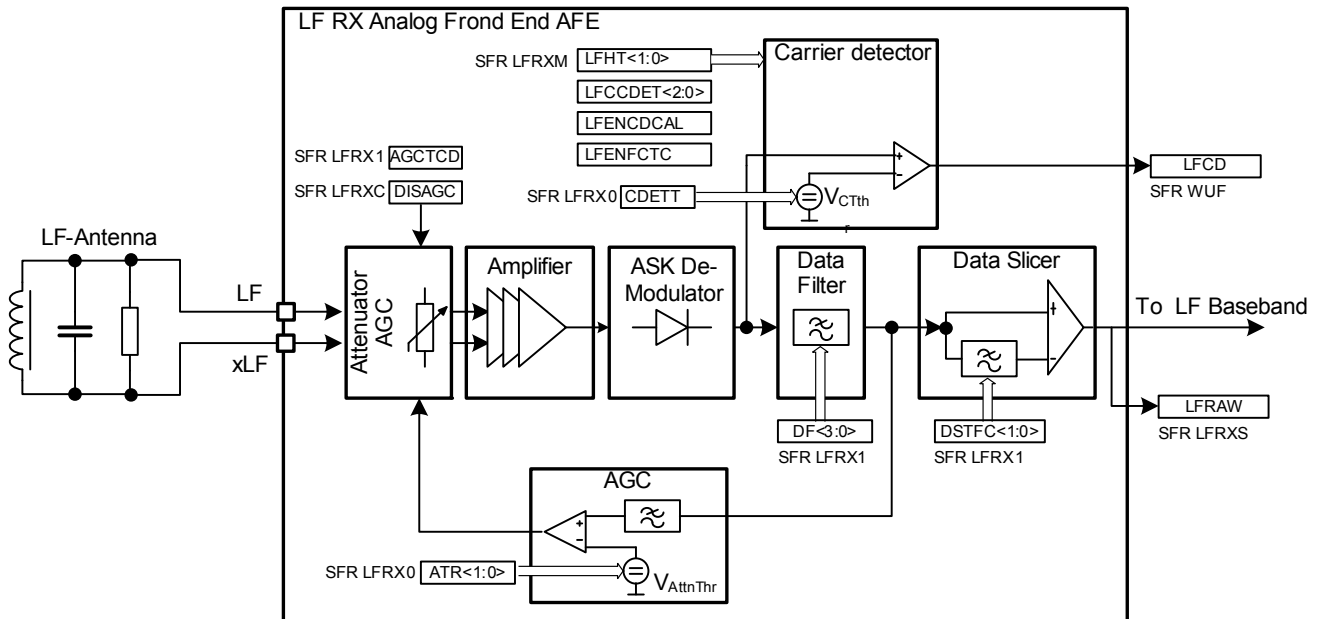

Figure 19 LF Receiver AFE Block Diagram

2.10.1.1 Attenuator (AGC) and Data Filter / Data Slicer

An input attenuator is provided to limit strong signals and interferers across the differential input. The attenuator detects the receiver input level and acts as an automatic gain control block (fast attack, slow decay). The attenuator decay slew rate can be adjusted by changing the decay slew rate using SFR bits LFRX1.7-6 [AGCTCD1-0].

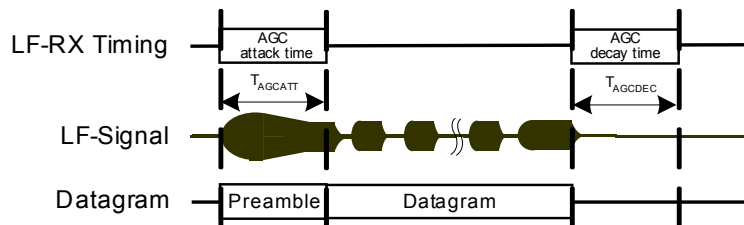

Figure 20 LF Receiver AFE Block Diagram

SFR LFRX1 is as well used to configure the data slicer and data filter according to the desired bit rate.

2.10.1.2 LF Carrier Detector

A level-detection circuit is implemented to determine if the carrier amplitude is above a predetermined level. This can be used to wake up the PMA5110 from the POWER DOWN state by an externally applied LF signal. In the POWER DOWN state, the LF Carrier Detector can either:

- Generate a wake-up and enter the RUN state as soon as an LF carrier is detected (SFR bit WUF.5 [LFCD] = 1_B)
- Enable the LF baseband and the 12 MHz RC HF oscillator in the POWER DOWN state to process the incoming LF signal by looking for a sync match or pattern match (SFR bits WUF.2,3 or 4 = 1_B). If a sync match or pattern match is received, the system controller generates a wake-up and enters the RUN state for further data processing.

Note: In both cases the overall LF sensitivity is determined by the LF Carrier Detector, since it determines if the LF baseband is enabled or disabled.

Since the LF-Signal is ASK modulated a carrier detect hold time is specified to prolong the carrier detect signal. A minimum hold time must be set depending on the data rate using LFCDM.1-0 [LFHT1-0] (The hold time functionality is illustrated in the following figure.

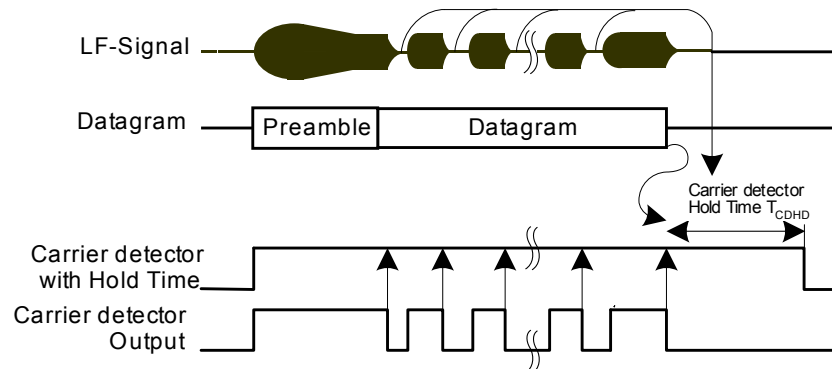

Figure 21 LF Receiver Carrier Detector Hold Time Behavior

2.10.1.2.1 Carrier Detector Threshold Calibration

To achieve high sensitivity, the Carrier Detector has to be calibrated to compensate for possible system noise and production spread. This calibration is enabled by setting SFR bit LFCDM.3 [LFENCDCAL] and is executed every time the LF Receiver is switched on (either manually by SFR bit LFRXC.2 [ENLFRX] or automatically by the LF On/Off Timer). Since this is done during the settling time of the LF Receiver, no extra delay is required for this calibration.

The Carrier Detector Threshold Level which is used for this calibration can be set by SFR bits LFRX0.7-4[CDETT].

Attention: To stabilize the specified sensitivity S_{LF1} (please refer to [Table 38](#)), the Library function *LFsensitivityCalibration()* has to be used (please refer to [\[1\]](#)).

If set, SFR bit LFCDM.2 [LFENFCTC] “freezes” the calibrated threshold level. If this bit is not set, the threshold will follow the mean value of the input signal, resulting in a threshold signal that is dependent on the LF signal strength and length.

If SFR bit LFCDM.2 [LFENFCTC] is set, a periodic recalibration is required, especially at higher temperatures since the “frozen” threshold level might drift after the Carrier Detector Freeze Hold Time (T_{CDCFH}). The recalibration is achieved automatically by the next off/on transition of the LF On/Off Timer or by disabling/enabling the LF Receiver manually by SFR bit LFRXC.2 [ENLFRX].

Note: If the LF Receiver is disabled/enabled manually at least one 2 kHz RC LP oscillator period has to be wait between off and on transition to achieve the automatic recalibration.

The following figure shows the timing behavior of the calibration.

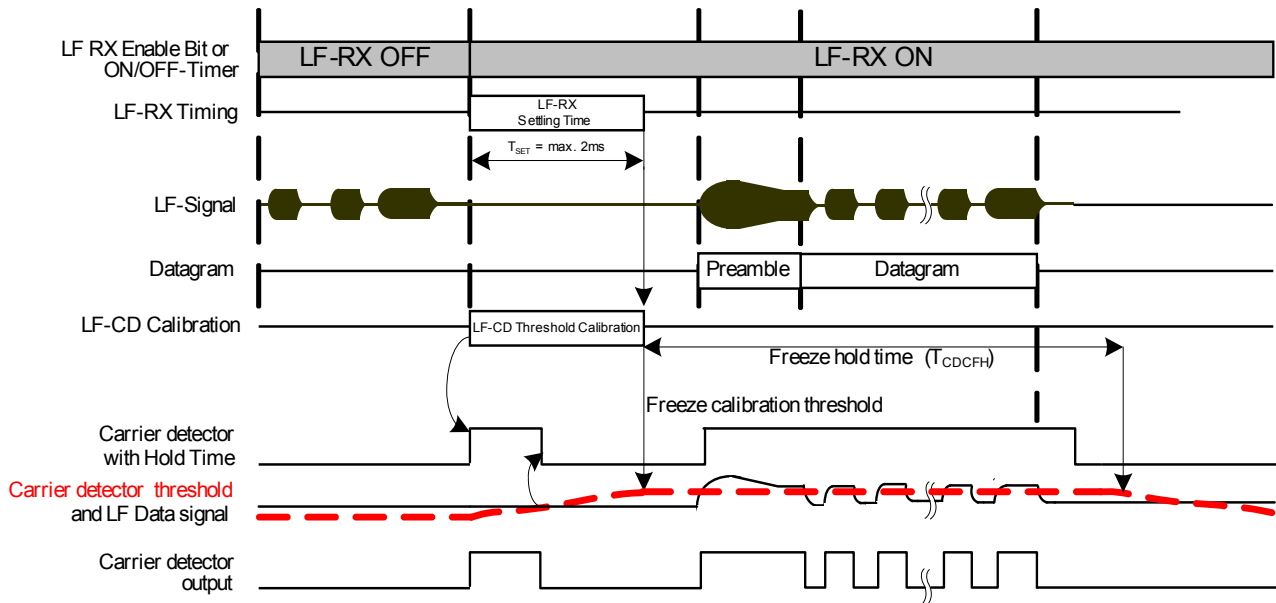

Figure 22 Carrier Detector Threshold Calibration Timing (with “freeze”)

2.10.1.2.2 Carrier Detector Filtering

To prevent the device from undesired carrier-detect wake-ups and to prevent the LF baseband and 12 MHz RC HF oscillator from being enabled due to interference, an LF Carrier Detector Filter is implemented. SFR LFCDFit is used to determine the filtering mode and the filtering time.

Three LF Carrier Detector filtering operation modes are available:

- LFCDFit.1-0 [CDFM] = 00_B
The LF Carrier Detector Filter is switched off so the wake-up functionality will remain without any filtering
- LFCDFit.1-0 [CDFM] = 10_B
The LF Carrier Detector Filter is always active - This mode is suitable for applications that use a carrier wake-up without any data transmission
- LFCDFit.1-0 [CDFM] = 01_B
The LF Carrier Detector Filter is deactivated when an ON pulse is received. The Preamble must contain an ON pulse (LF carrier active) longer than the selected filter time to enable the LF baseband and the 12 MHz RC HF oscillator. After the ON-pulse is received, the filter is disabled until no more data is received. Depending on the selected hold time (SFR bits LFCDM.1-0 [LFHT1-0]), the filter will be re-enabled after the last received bit.

The following figure shows the behavior of the various modes.

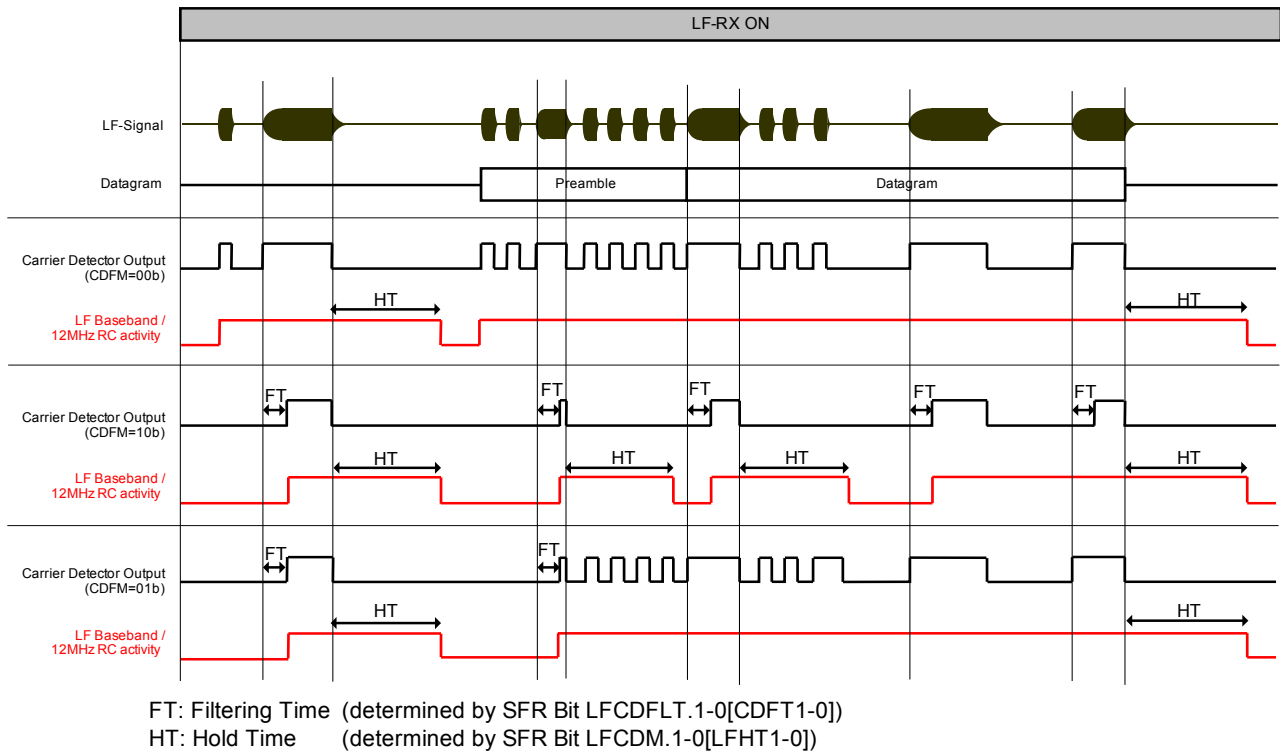

Figure 23 LF Receiver Carrier Detector Filtering

2.10.2 LF Receiver On/Off Timer

An On/Off Timer is implemented to reduce the LF Receiver current consumption in POWER DOWN state. It can be enabled by SFR bit LFRXC.3 [ENOOTIM].

The LF Receiver Analog Frontend will be periodically switched on or off corresponding to the timer settings. The current state of the LF Receiver (on or off) is available in SFR bit LFSYNCFG.7[LFCD A].

The LF Receiver On/Off Timer incorporates a precounter (SFR LFOOTP) as time base and a post counter for independently setting the On time and the Off time (SFR LFOOT).

2.10.2.1 LF Receiver On/Off Timer Calibration

The calibration process is done automatically by a Library function (see [1]). The time base is automatically calibrated to 50 ms by this function. If another (uncalibrated) time base is needed, SFR LFOOTP can be configured manually by using the equation shown in Figure 24.

$$timebase[s] = \frac{LFOOTP + 1}{f_{2\text{ kHz RC LP Oscillator}} [Hz]}$$

Figure 24 Calculation of time base for LF Receiver On/Off Timer

The On time and the Off time can be configured individually using SFR LFOOT. They can be calculated using the equations shown in **Figure 25** and **Figure 26**.

$$ontime[s] = \frac{(ONTIM + 1) \cdot \left(\text{Integer} \left(\frac{LFOOTP}{4} \right) + 1 \right)}{f_{2kHzRC\ LP\ Oscillator} [Hz]} = \frac{(ONTIM + 1) \cdot \left(\text{Integer} \left(\frac{LFOOTP}{4} \right) + 1 \right) \cdot timebase [s]}{LFOOTP + 1}$$

Figure 25 Calculation of On time for LF Receiver On/Off Timer

$$offtime[s] = \frac{(OFFTIM + 1) \cdot (LFOOTP + 1) \cdot 4}{f_{2kHzRC\ LP\ Oscillator} [Hz]} = (OFFTIM + 1) \cdot timebase [s] \cdot 4$$

Figure 26 Calculation of Off time for LF Receiver On/Off Timer

2.10.3 LF Receiver Baseband Processor

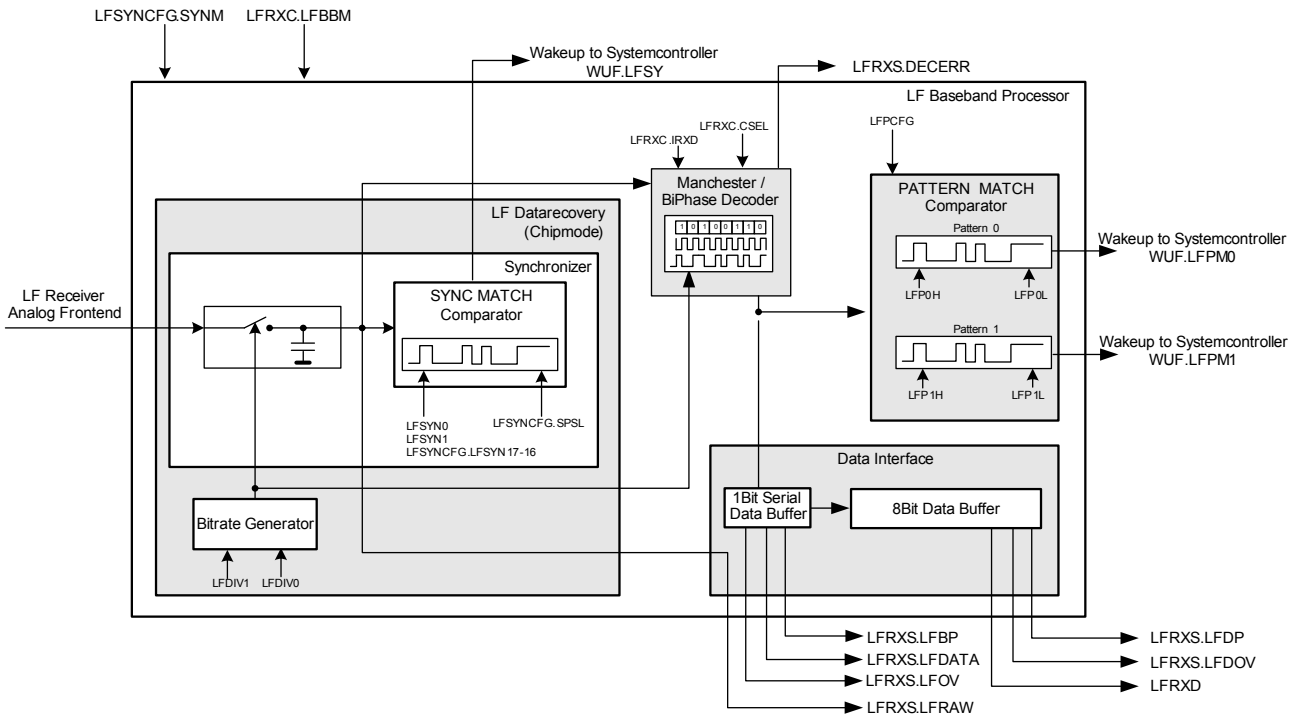

Figure 27 LF Receiver Baseband

The LF Receiver Baseband Processor can be configured to receive the following datagram formats by using the SFR bits LFSYNCFG.1-0 [SYNM1-0].

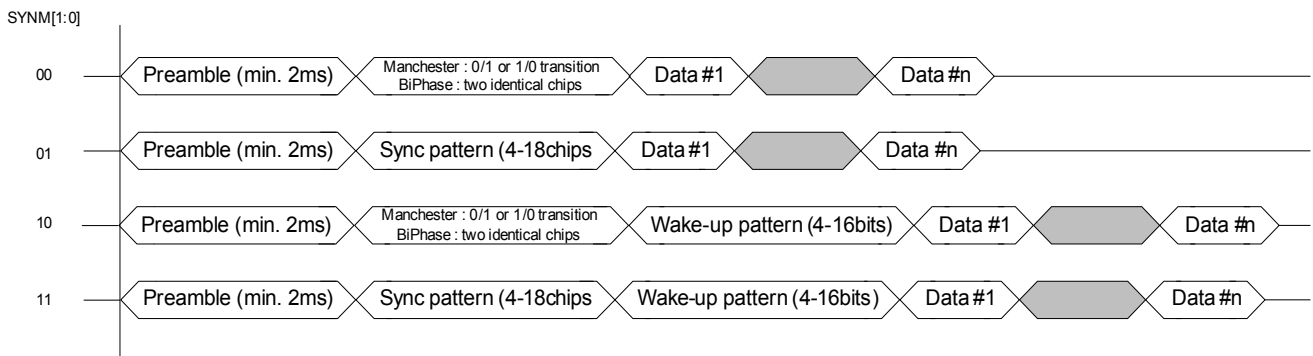

Figure 28 LF Receiver Baseband Configurations

2.10.3.1 Synchronizer

A sync pattern of up to 18 chips can be specified (SFR LFSYN1, SFR LFSYN0 and SFR bits LFSYNCFG.5-4 [LFSYN17-16]) and compared to the synchronized received bit stream. The comparison takes place before decoding, so sync patterns with code violations can also be detected. Code violations are defined to have at least three consecutive chips without level transitions.

Note: The sync pattern should maintain a 50/50 ratio of LOW / HIGH chips to preserve a DC Level of 50% and must not contain more than 3 consecutive chips at the same level.

2.10.3.2 Bit rate Generator

The SFR LFDIV1 and SFR LFDIV0 define the LF Receiver bit rate. Depending on the selected system clock, either the left or the right formula has to be used.

$$\left(LFDIV1/0 = \frac{f_{12MHzRC\ HF\ Oscillator} [Hz]}{16 \cdot baudrate \left[\frac{1}{s} \right]} \right) \text{ or } \left(LFDIV1/0 = \frac{f_{Crystal} [Hz]}{32 \cdot baudrate \left[\frac{1}{s} \right]} \right)$$

Figure 29 Calculation of LF Receiver bit rate

For sync match and pattern match, the bit rate generator is needed in POWER DOWN state. The only available system clock in POWER DOWN state is the 12 MHz RC HF oscillator.

To avoid switching bit rates, the system clock should never be changed during LF reception is running.

Due to the drift of the 12 MHz RC HF oscillator, a calibration mechanism is provided as a Library function and is described in [1]. This Library function automatically configures SFR LFDIV0 and SFR LFDIV1.

2.10.3.3 LF Data Decoder

The decoder can be used for Manchester or BiPhase encoded data. If a code violation is detected SFR bit LFRXS.6 [DECERR] is set to 1_B. **Figure 30** shows a summary of the available coding schemes and the appropriate register settings.

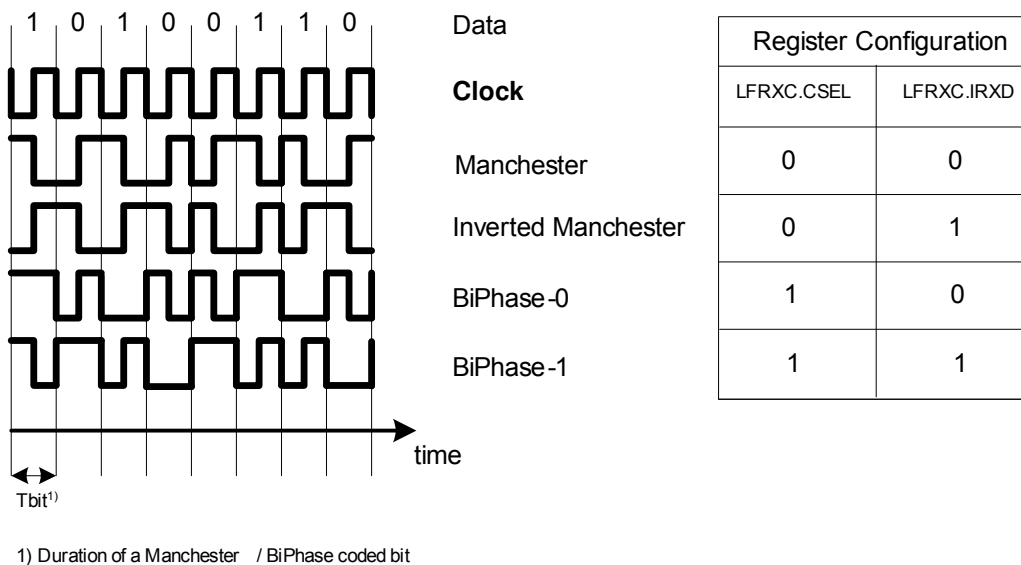

Figure 30 LF Receiver Data Decoder schemes

2.10.3.4 Wake-up Pattern Detector

Two different wake-up patterns with a length of 4, 8 or 18 bits can be stored by using SFRs LFP0H, LFP0L, LFP1H and LFP1L.

SFR WUM determines on which pattern (pattern 0, pattern 1, or both) a wake-up occurs.

2.10.3.5 LF Receiver Data Interface

The received data can be read by the microcontroller using the following different interfaces:

- 8 bit data byte (synchronized, Manchester/BiPhase decoded)
- Serial bit stream data (synchronized, Manchester/BiPhase decoded)

- RAW data (synchronized, chip level)
- RAW Carrier Detect (not synchronized)

2.10.3.5.1 8 bit data byte

Synchronized and decoded data bytes are received using SFR LFRXD. Decoded bits are shifted into an 8 bit receive buffer, until a byte boundary is reached. The received byte is then shifted into the SFR LFRXD, and a flag SFR bit LFRXS.3 [LFDP] is set, while the following byte starts shifting into the receive buffer. If the SFR LFRXD is not read before the following byte is received, it will be overwritten and an overflow flag SFR bit LFRXS.4 [LFDOV] is set.

2.10.3.5.2 Serial bit stream data

Synchronized and decoded serial data is received in the SFR bit LFRXS.0 [LFDATA]. A flag SFR bit LFRXS.1 [LFBP] is set if data is pending, while the following bit is buffered. If the SFR bit LFRXS.0 [LFDATA] is not read before the following bit is received, it will be overwritten, and an overflow flag SFR bit LFRXS.2 [LFOV] is set.

2.10.3.5.3 RAW data

Synchronized and not decoded serial data (on the chip level) can be read by the microcontroller using SFR bit LFRXS.5 [LFRRAW]. This can be used for any coding scheme.

2.10.3.5.4 RAW Carrier Detect

Not synchronized and not decoded serial data can be read by the microcontroller using SFR bit LFRXS.7 [CDRAW]. This indicates if a carrier signal is currently present (SFR bit LFRXS.7[CDRAW] = 1_B) or not (SFR bit LFRXS.7 [CDRAW] = 0_B).

2.10.4 Register Description

Table 17 Registers Overview

Register Short Name	Register Long Name	Offset Address	Wakeup Value	Page Number
LFRXS	LF Receiver Status Register	A4 _H	00 _H	105
LFRXD	LF Receiver Data Register	A5 _H	00 _H	104
LFSYN0	LF Sync Pattern 0	A6 _H	UUUUUUUU _B	106
LFSYN1	LF Sync Pattern 1	A7 _H	UUUUUUUU _B	106
LFSYNCFG	LF SYNC Matching Configuration Register	AF _H	XUUUUUUUB	107
LFCDFit	LF Carrier Detect Filtering	B2 _H	00UU00UU _B	94
LFDIV0	LF Division Factor low byte	B3 _H	UUUUUUUU _B	96
LFDIV1	LF Division Factor high byte	B4 _H	0000UUU _B	96
LFCDM	LF Carrier Detector Mode	B5 _H	UUUUUUUU _B	95
LFRX1	LF Receiver Configuration Register 1	B6 _H	UUUUU0UU _B	102
LFRX0	LF Receiver Configuration Register 0	B7 _H	UUUUUUUU _B	101
LFP0L	LF Pattern 0 Detector Sequence Data LSB	BE _H	UUUUUUUU _B	99
LFP0H	LF Pattern 0 Detector Sequence Data MSB	BF _H	UUUUUUUU _B	98
LFOOTP	LF On/Off Timer Precounter	C5 _H	UUUUUUUU _B	98
LFOOT	LF On/Off Timer Configuration Register	C6 _H	UUUUUUUU _B	97
LFPCFG	LF Pattern Detection Configuration Register	C7 _H	0000UUU _B	100
LFP1L	LF Pattern 1 Detector Sequence Data LSB	CE _H	UUUUUUUU _B	100
LFP1H	LF Pattern 1 Detector Sequence Data MSB	CF _H	UUUUUUUU _B	99
LFRXC	LF Receiver Control Register	F9 _H	UUUUUUUU _B	103

LF Division Factor low byte

LFDIV0	Offset	Wakeup Value	Reset Value
LF Division Factor low byte	B3 _H	UUUUUUUU _B	00 _H

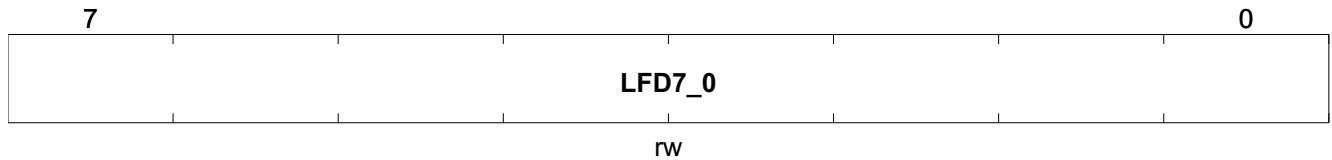

Field	Bits	Type	Description
LFD7_0	7:0	rw	LF bit rate generator division factor bit 7 down to bit 0

LF Division Factor high byte

LFDIV1	Offset	Wakeup Value	Reset Value
LF Division Factor high byte	B4 _H	0000UUU _B	00 _H

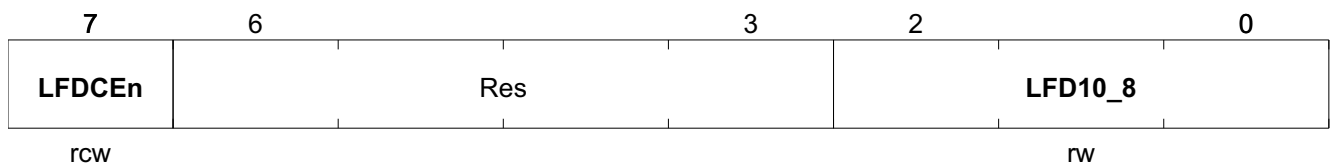

Field	Bits	Type	Description
LFDCEn	7	rcw	LF Division Calibration Enable <i>Note: Under control of Library functions</i>
Res	6:3		Reserved
LFD10_8	2:0	rw	LF bit rate generator division factor bit 10 down to bit 8

Note: These SFRs can be modified manually as well for using other (uncalibrated) bit rates.

LF On/Off Timer Configuration Register

LFOOT	Offset	Wakeup Value	Reset Value
LF On/Off Timer Configuration Register	C6_H	UUUUUUUU_B	00_H

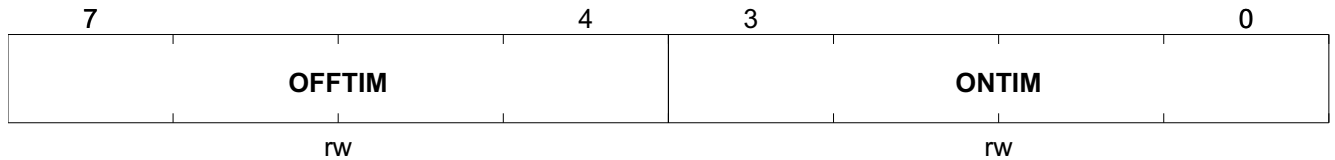

Field	Bits	Type	Description
OFFTIM	7:4	rw	<p>Off time (MSB-LSB) Binary weighted Off time.</p> <p>Example: If time base is set to 50ms in LFOOTP the following value range is available (please refer to Figure 26 “Calculation of Off time for LF Receiver On/Off Timer” on Page 89): 0000_B 200ms ... 1111_B 3.2s</p>
ONTIM	3:0	rw	<p>On time (MSB-LSB) Binary weighted On time.</p> <p>Example: If time base is set to 50ms in LFOOTP the following value range is available (please refer to Figure 25 “Calculation of On time for LF Receiver On/Off Timer” on Page 89): 0000_B 12.5ms ... 1111_B 200ms</p>

LF On/Off Timer Precounter

LFOOTP	Offset	Wakeup Value	Reset Value
LF On/Off Timer Precounter	C5 _H	UUUUUUUU _B	64 _H

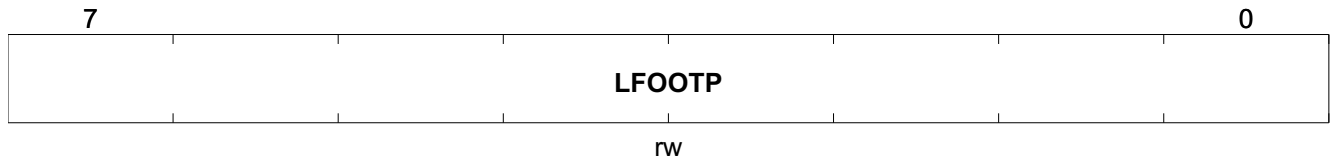

Field	Bits	Type	Description
LFOOTP	7:0	rw	LF Receiver On/Off Timer Precounter setting

LF Pattern 0 Detector Sequence Data MSB

LFP0H	Offset	Wakeup Value	Reset Value
LF Pattern 0 Detector Sequence Data MSB	BF _H	UUUUUUUU _B	FF _H

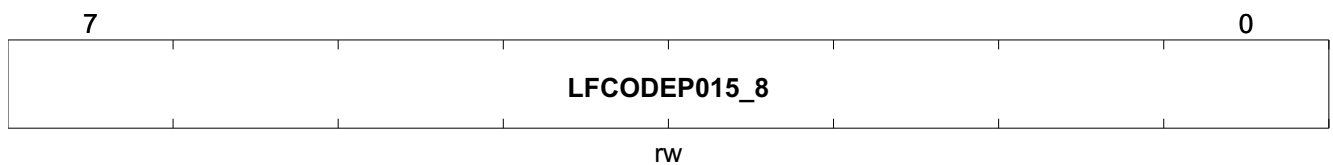

Field	Bits	Type	Description
LFCODEP015_8	7:0	rw	Code pattern 0 sequence bit 15 down to bit 8

LF Pattern 0 Detector Sequence Data LSB

LFP0L	Offset	Wakeup Value	Reset Value
LF Pattern 0 Detector Sequence Data LSB	BE _H	UUUUUUUU _B	FF _H

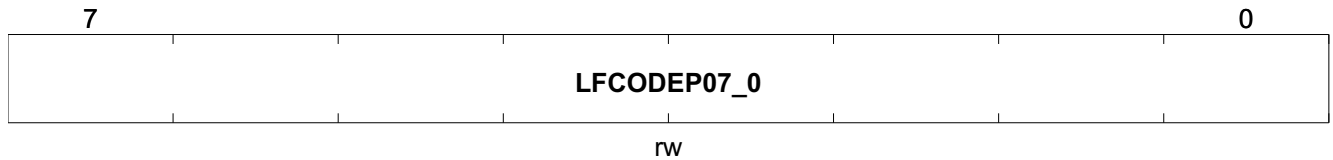

Field	Bits	Type	Description
LFCODEP07_0	7:0	rw	Code pattern 0 sequence bit 7 down to bit 0

LF Pattern 1 Detector Sequence Data MSB

LFP1H	Offset	Wakeup Value	Reset Value
LF Pattern 1 Detector Sequence Data MSB	CF _H	UUUUUUUU _B	FF _H

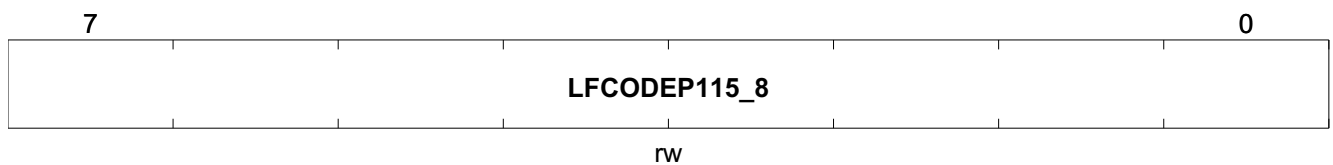

Field	Bits	Type	Description
LFCODEP115_8	7:0	rw	Code pattern 1 sequence bit 15 down to bit 8

LF Pattern 1 Detector Sequence Data LSB

LFP1L	Offset	Wakeup Value	Reset Value
LF Pattern 1 Detector Sequence Data LSB	CE_H	UUUUUUUU_B	FF_H

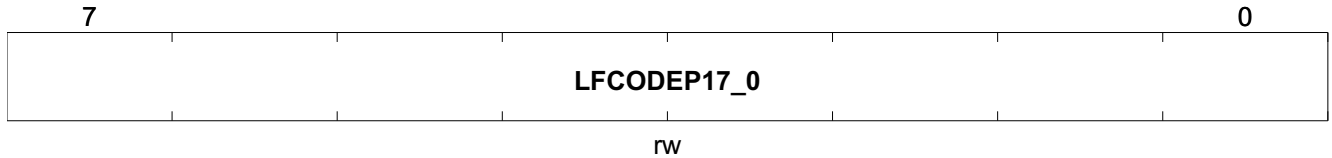

Field	Bits	Type	Description
LFCODEP17_0	7:0	rw	Code pattern 1 sequence bit 7 down to bit 0

LF Pattern Detection Configuration Register

LFPCFG	Offset	Wakeup Value	Reset Value
LF Pattern Detection Configuration Register	C7_H	0000UUU_B	00_H

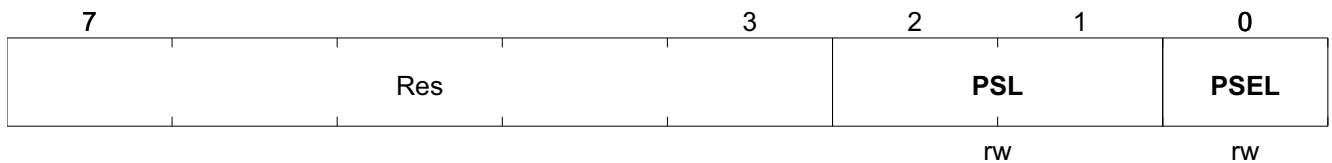

Field	Bits	Type	Description
Res	7:3		Reserved
PSL	2:1	rw	Pattern sequence length (MSB-LSB) 00 _B 4 bit pattern length (LFP0L.[3:0] or LFP1L.[3:0]) 01 _B 8 bit pattern length (LFP0L.[7:0] or LFP1L.[7:0]) 10 _B 16 bit pattern length (LFP1H.[15:8] / LFP1L.[7:0] or LFP0H.[15:8] / LFP0L.[7:0]) 11 _B Reserved
PSEL	0	rw	Pattern select 0 _B Only wake-up pattern 0 (LFP0L and LFP0H) can generate a pattern match wake-up. 1 _B Both, wake-up pattern 0 (LFP0L and LFP0H) and wake-up pattern 1 (LFP1L and LFP1H) can generate a pattern match wake-up.

LF Receiver Configuration Register 0

The SFR LFRX0 determines the attenuation of the LF input signal (SFR bit LFRX0.0 [VDIV1-0]) and the threshold for the Carrier Detector (SFR bits LFRX0.7-4 [CDETT3-0]). Please refer to [Product Characteristics](#) for proper setting of these bits.

LFRX0	Offset	Wakeup Value	Reset Value
LF Receiver Configuration Register 0	B7_H	UUUUUUUU_B	39_H

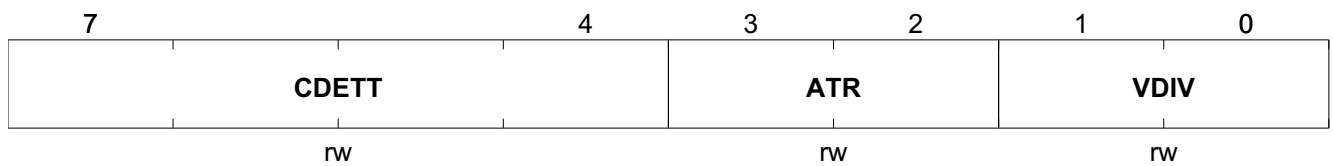

Field	Bits	Type	Description
CDETT	7:4	rw	Carrier Detector Threshold Level Selection Use PMA Library function <code>LFSensitivityCalibration()</code> to automatically configure these bits. Please refer to [1] .
ATR	3:2	rw	Attenuator Threshold Selection <i>Note: Must be set to 10_B</i>
VDIV	1:0	rw	Antenna Voltage Divider Factor Selection 00 _B Divided by 9 01 _B Divided by 1 10 _B Divided by 29 11 _B Reserved

LF Receiver Configuration Register 1

LFRX1 Offset Wakeup Value Reset Value
LF Receiver Configuration Register 1 B_{6H} UUUUU0UU_B 31_H

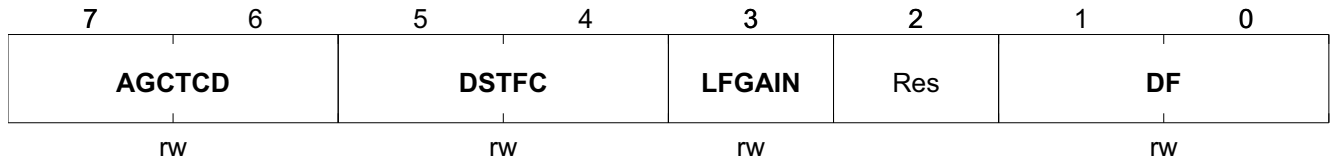

Field	Bits	Type	Description
AGCTCD	7:6	rw	AGC Time Constant Decay Slew Rate Selection <i>Note: Must be set to 00_B</i>
DSTFC	5:4	rw	Data Slicer Threshold Filter Corner Frequency Selection <i>Note: Must be set to 00_B</i>
LFGAIN	3	rw	LF Receiver Front End Gain Select <i>Note: Must be set to 1_B</i>
Res	2		Reserved
DF	1:0	rw	Data Filter Corner Frequency Selection 00 _B Reserved 01 _B Recommended for a data rate of 2000/3900/4000 bit/s 10 _B Reserved 11 _B Reserved

LF Receiver Control Register

LFRXC	Offset	Wakeup Value	Reset Value
LF Receiver Control Register	F9_H	UUUUUUUU_B	00_H

7	6	5	4	3	2	1	0
CDRECAL	DISAGC	LFBBM		ENOOTIM	ENLFRX	IRXD	CSEL
rw	rw	rw		rw	rw	rw	rw

Field	Bits	Type	Description
CDRECAL	7	rw	Carrier Detector Threshold re-calibration <i>Note: This bit must be set to 0_B</i>
DISAGC	6	rw	Disable Automatic Gain Control (AGC) 0 _B AGC is enabled 1 _B AGC is disabled
LFBBM	5:4	rw	LF Baseband Processor Mode Selection 00 _B Disabled: The entire digital part of the receiver is disabled. The LF Analog Frontend including Carrier Detector is still active (if enabled by ENLFRX) 01 _B Raw data recovery: The digital frontend and the synchronizer are active. Data is recovered at chip level and can be handled by the microcontroller. This mode can be used for the implementation of custom coding and synchronization schemes. 10 _B Raw/decoded data recovery: The full LF baseband functionality including the decoding of Manchester/BiPhase coded data is available. 11 _B Reserved
ENOOTIM	3	rw	Enable On/Off Timer 0 _B LF Receiver is always on (if also enabled by ENLFRX) 1 _B LF Receiver is controlled by On/Off Timer (if also enabled by ENLFRX)
ENLFRX	2	rw	Enable LF Receiver 0 _B LF Receiver disabled 1 _B LF Receiver enabled (Controlled by ENOOTIM)
IRXD	1	rw	Invert LF Receiver data 0 _B Data not inverted 1 _B Data inverted

Functional Description

Field	Bits	Type	Description
CSEL	0	rw	Decoder Code Select IRXD=0 _B 0 _B Manchester coded data 1 _B BiPhase 0 coded data IRXD=1 _B 0 _B Inverted Manchester coded data 1 _B BiPhase 1 coded data

LF Receiver Data Register

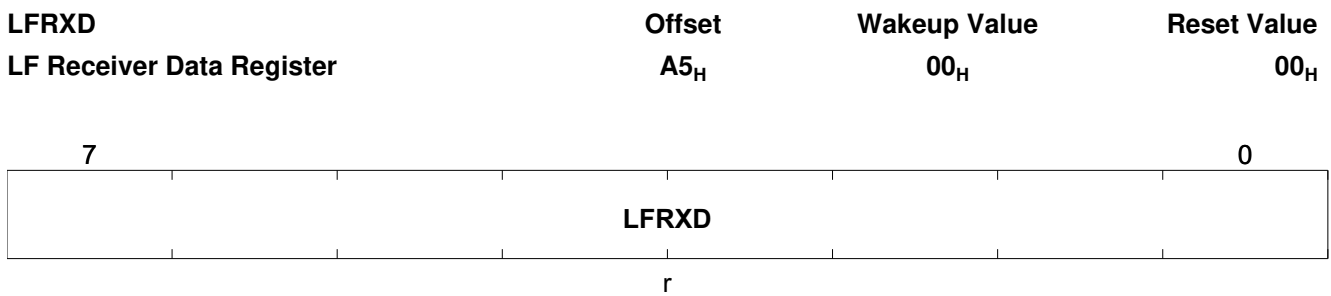

Field	Bits	Type	Description
LFRXD	7:0	r	LF Receiver data register

LF Receiver Status Register

LFRXS	Offset	Wakeup Value	Reset Value
LF Receiver Status Register	A4_H	00_H	00_H

7	6	5	4	3	2	1	0
CDRAW	DECERR	LFRAW	LFDOV	LFDP	LFOV	LFBP	LFDATA
r	rc	r	rc	rc	rc	rc	r

Field	Bits	Type	Description
CDRAW	7	r	LF Carrier detect raw data
DECERR	6	rc	Manchester/Biphase decode error 0 _B No error detected 1 _B Decode error detected
LFRAW	5	r	LF Receiver raw data
LFDOV	4	rc	LF data byte overwritten 0 _B No error detected 1 _B LF data byte overwritten
LFDP	3	rc	LF data byte pending If this bit is set LF data can be read from LFRXD
LFOV	2	rc	LF serial decoded data overwritten 0 _B No error detected 1 _B LF serial decoded data overwritten
LFBP	1	rc	LF serial decoded data pending If this bit is set new LF serial decoded data is available at LFDATA since the last read access to LFRXS
LFDATA	0	r	LF serial decoded data

LF Sync Pattern 0

LFSYN0	Offset	Wakeup Value	Reset Value
LF Sync Pattern 0	A6 _H	UUUUUUUU _B	FF _H

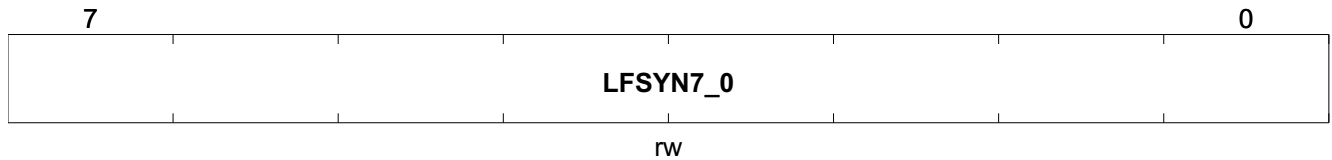

Field	Bits	Type	Description
LFSYN7_0	7:0	rw	LF Sync Pattern Chip 7 - Chip 0

LF Sync Pattern 1

LFSYN1	Offset	Wakeup Value	Reset Value
LF Sync Pattern 1	A7 _H	UUUUUUUU _B	FF _H

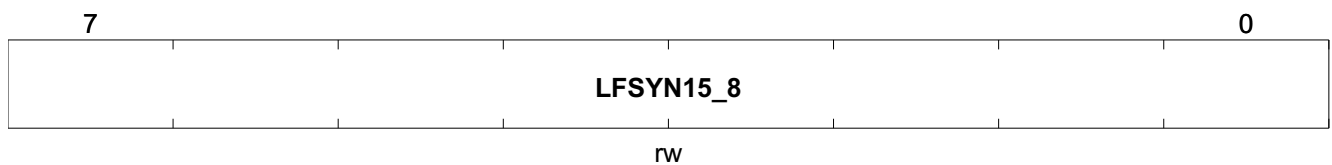

Field	Bits	Type	Description
LFSYN15_8	7:0	rw	LF Sync Pattern Chip 15 - Chip 8

2.11 Sensor Interfaces and Data Acquisition

The PMA5110 has two internal sensors to acquire environmental data, two highly sensitive differential analog interfaces with 4 programmable gain factors (from 76 +20 %, 60 +20 %, 50 +20 % and 38 +20 %), and one standard differential analog interface (gain factor 1):

- Temperature sensor
- Battery voltage monitoring
- External data through analog interface

The analog data is acquired and digitalized by the internal 10-bit ADC. Measurement routines for acquiring temperature and battery voltage data are available within the Function Library that is described in [1].

2.11.1 Sensor Interface

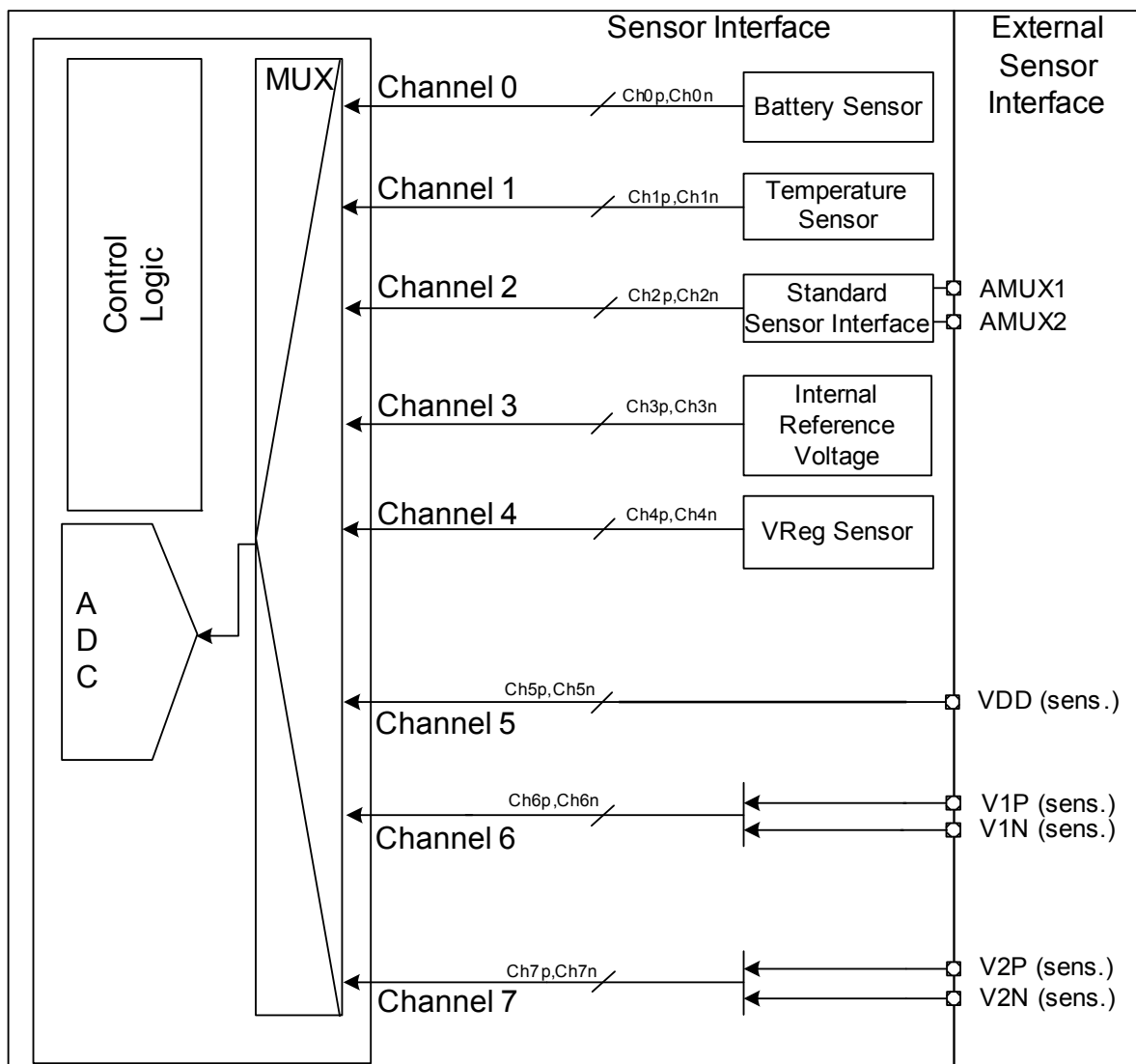

Figure 31 Block Diagram of the Sensor Interface

The sensor interface connects to the external sensors and to the internal (on-chip) temperature and battery-voltage sensors.

All signal channels can be configured for differential or single-ended operation. Differential operation is only recommended for signals in which the common-mode voltage is stable, while the positive and negative signal voltages vary symmetrically around the common-mode voltage.

The input multiplexer selects one channel for the input signal and one channel for the reference voltage to the ADC. Any channel can be selected as the reference except channels 6 and 7, which are specially adapted to the low-level signals from external sensors.

2.11.1.1 Two Differential Highly Sensitive Interfaces to External Sensors

Differential highly sensitive sensor interface 1 (Channel 6)

V1P/V1N are the positive/negative differential voltage inputs.

Differential highly sensitive sensor interface 2 (Channel 7)

V2P/V2N are the positive/negative differential voltage inputs.

Channel gain selection

The SFR bit ADCC1.5-4 [GAIN1-0] gain factor selection allows the selection of the sensitivity of the analog input channels 6 and 7. The gain factor is one for all other input channels (see [Table 18 “Selection of the Gain Factor” on Page 109](#)).

Table 18 Selection of the Gain Factor

Gain factor (gain)	Channel ADCM.CS2-0	GAIN1	GAIN0
76 +/- 20%	11X	0	0
60 +/- 20%	11X	0	1
50 +/- 20%	11X	1	0
38 +/- 20%	11X	1	1
1	Others	0	0
1	Others	0	1
1	Others	1	0
1	Others	1	1

Sensor Excitation

Sensors connected to channel 6 or 7 can have their supply voltages provided by the PMA5110. For channel 6, connect the supply terminals of the sensor between VDD(sens) and VM1 (pin 3). For channel 7, use VDD(sens) and VM2. The supply is switched on only when a measurement of the corresponding channel is done. A settling time delay between sensor power-on and measurement can be programmed, refer to [Chapter 2.11.4.1.2](#).

Wheatstone Bridge Sensor Connection

Wheatstone bridges can be used to set the operating point of external sensors, if needed. [Figure 32 “Wheatstone Bridge Sensor Connection” on Page 110](#) shows the connection of two wheatstone bridges to the differential high sensitivity sensor interfaces 1 and 2 (channel 6 and channel 7).

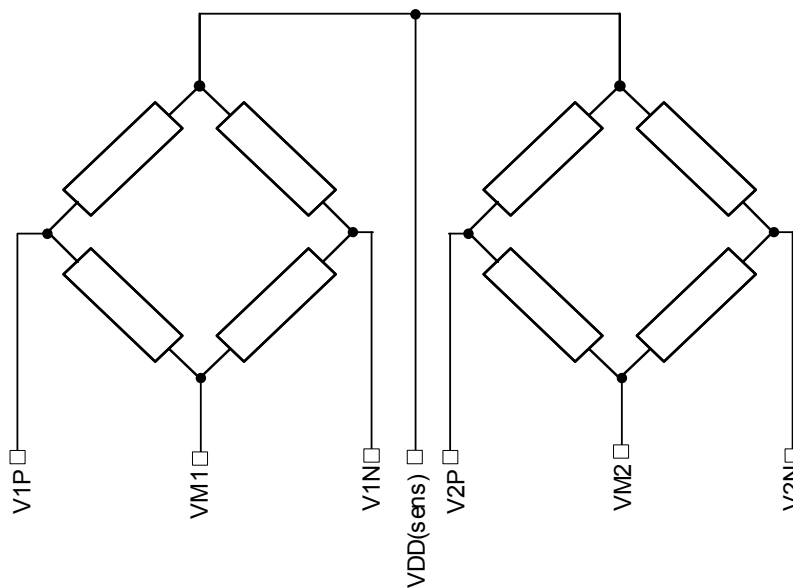

Figure 32 Wheatstone Bridge Sensor Connection

2.11.1.2 Interface to Other Signals

Battery-voltage Interface (Channel 0)

The positive input to the battery-voltage signal is derived by dividing voltage V_{Bat} by 3.5. The negative input is connected to GND. The battery voltage is converted with a resolution of approximately 4.1 mV, using an internal reference voltage of 1210 mV (channel 3) as a reference.

Temperature-sensor Interface (Channel 1)

The temperature signal to the ADC is a single-ended signal, with a temperature-sensitive voltage between 500 and 1100 mV. The temperature-sensor signal is digitized with a resolution of approximately 0.5°C, using an internal reference voltage of 1210 mV (channel 3) as a reference.

Standard-sensor Interface (Channel 2)

The positive input signal must be applied at AMUX1, and the negative input at AMUX2.

2.11.1.3 Reference Voltages

When channel 6 or 7 is selected as input to the ADC, the reference voltage should be identical to the supply voltage of the sensor bridge, in order to get correct ratiometric operation. If the sensor bridge is connected between the VDD(sens) and VM1 (or VM2) pins of the PMA5110, channel 5 will provide the correct reference voltage.

If the sensor is supplied by external power, the positive and negative supply voltages of the sensor bridge should be connected to channel 2, and this channel should be used as a reference (see [Figure 33](#)). The supply voltage of the sensor must always be within the range GND to V_{REG} .

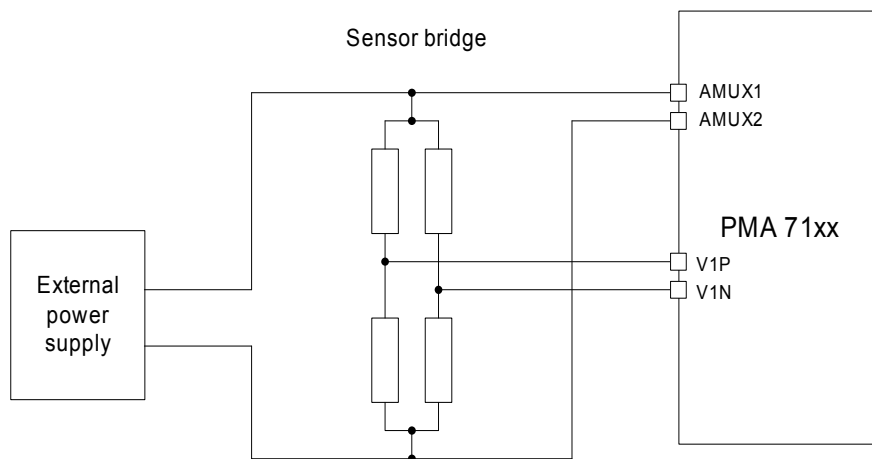

Figure 33 External Sensor Use Channel 2 as Reference Voltage

3 channels on the ADC input multiplexer carry voltages that are intended as reference voltages for the converter:

Internal Reference Voltage (Channel 3)

This reference is a nominal voltage of 1210 mV. It is intended as a reference for the temperature and V_{Bat} measurements.

VREG Reference (Channel 4)

This reference is the V_{REG} voltage. This is the highest allowable input voltage to the ADC, and is meant as a reference for the test signal, to allow as large a test signal as possible.

BRIDGE SUPPLY Reference (Channel 5)

When channel 6 or 7 is selected as the input to the ADC, the reference voltage is the bridge supply voltage. A multiplexer selects the appropriate negative bridge supply. This reference must be used with the ratiometric sensors in order to achieve an accuracy that is independent of the battery voltage.

2.11.2 Temperature Sensor

Temperature measurement is performed by a dedicated Library function.

See [Temperature Sensor Characteristics](#) for the sensor specification.

2.11.3 Battery Voltage Monitor

Battery voltage measurement is performed by a dedicated Library function.

See [Battery Sensor Characteristics](#) for the sensor specification.

2.11.4 Analog to Digital Converter (ADC)

The ADC is a fully differential charge-balancing 10-bit converter. It uses a technique known as redundant successive approximation, which requires 12 decisions to arrive at a 10-bit result. The redundancy means that the ranges of the successive approximation partially overlap, making the conversion more robust to noise.

The ADC can perform sub conversions with any number of bits. This means that the charge redistribution is done with the result of the previous conversion as a starting point, and doing the comparator decisions only for the selected number of less significant bit positions.

A digitally controlled attenuator allows the gain setting of the highly sensitive ADC inputs. At ADC inputs, inverters are used to perform two identical conversions with inverted comparator input signals to compensate comparator offset digitally. They are controlled by the SFR bit ADCC1.6 [CSI] (see [ADC Configuration Register 1](#)). If the average of the 2 measurements is taken, the offset of the comparator is canceled.

2.11.4.1 ADC Timing

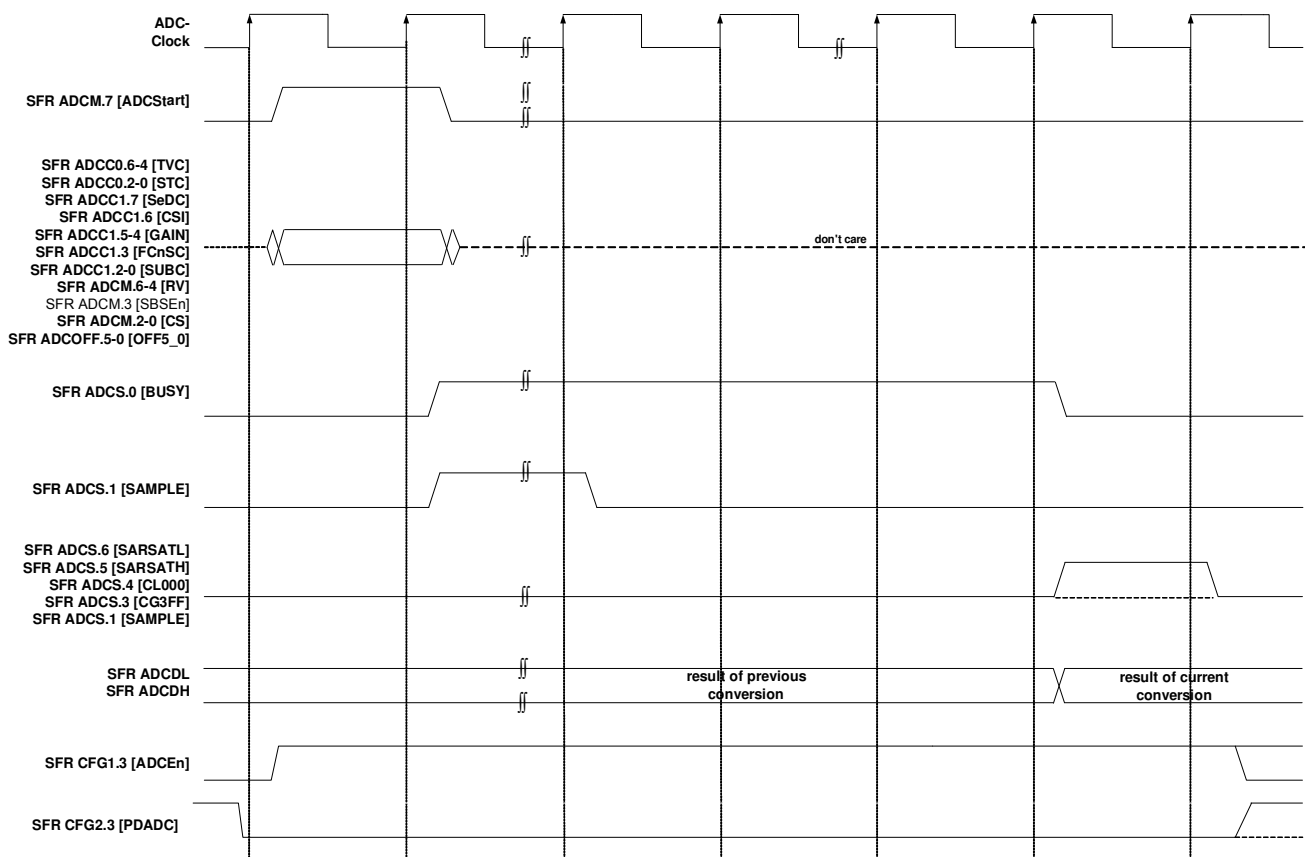

Figure 34 ADC Timing diagram (standard conversion)

ADC power (VADC) must be turned on (using CFG2.3 [PDADC]) before the ADC is enabled (using CFG1.3 [ADCEn]). AD conversions can then be started by setting ADCM.7 [ADCStart] to 1_B. ADCM.3 [SBSEn] can be used to enable the Wheatstone Bridge supply if needed. The timing diagram of a conversion is shown above. ADC-Start and all other control signals are latched with the following rising edge of the ADC-Clock. This generates the status bits ADCS.0 [BUSY] as well as ADCS.1 [SAMPLE] which indicates the sample and hold activity of the channel input signals. The result registers ADCDH and ADCDL are written at the same time. With the next rising edge of the ADC-Clock the result bits are stable. ADC power (VADC) can then be turned off again

by setting CFG2.3 [PDADC]. Only the analog part of the ADC is powered off, thus the result register will not be affected thereby.

2.11.4.1.1 Clock Divider

An ADC clock divider allows the adaption of the ADC speed to the CPU8051 and peripheral units clock f_{CPU} . The clock divider factor settings are selected by ADCC0.6-4 [TVC]. The ADC clock frequency is calculated with equation shown in [Figure 35](#).

$$f_{ADC} [Hz] = \frac{f_{CPU} [Hz]}{TVC}$$

TVC .. ADCC0.6-4 [TVC]

Figure 35 ADC frequency calculation

2.11.4.1.2 Sample Time Delay

The sample time delay (Sample time adjustment factor STC) of the analog input channel is selected by the bits ADCC0.2-0 [STC2-0]. The sample time t_{sample} of the analog input channels can be calculated using the formula shown in [Figure 36 “ADC sample time delay” on Page 113](#).

$$t_{sample} [s] = \frac{1}{f_{CPU} [Hz]} \cdot TVC \cdot STC$$

TVC .. ADCC0.6-4 [TVC]
STC .. ADCC0.2-0 [STC]

Figure 36 ADC sample time delay

The scheme of sample time generation is drawn in [Figure 37 “Generation of ADC clock and the sample time signal” on Page 113](#).

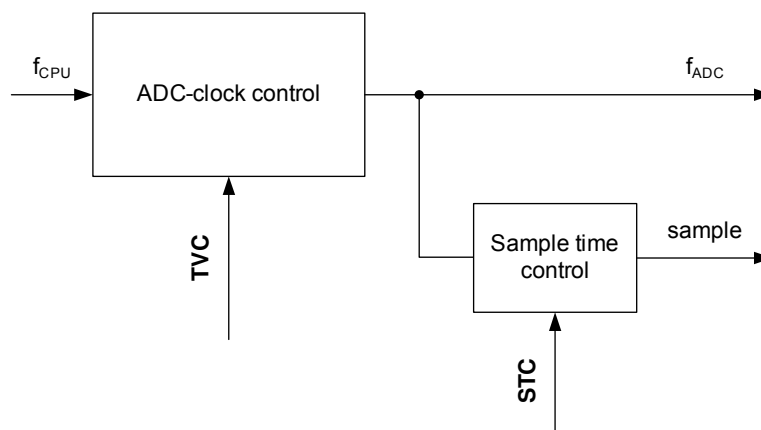

Figure 37 Generation of ADC clock and the sample time signal

2.11.4.1.3 Conversion Time

The ADC conversion time has three contributors. First, the sample time where the input signal voltage level is stored in the sampling capacitors. Second, the successive approximation to determine the output code. A full conversion needs 12 ADC clock cycles to produce a 10 bit conversion result. Third, 2 CPU clock cycles f_{CPU} to synchronize all input and output signals to the interface. The conversion time is calculated with the formula shown in [Figure 38 “Calculation of the ADC conversion time using full conversion” on Page 114](#).

$$t_{conv}[s] = \frac{1}{f_{CPU}[Hz]} \cdot (TVC \cdot (STC + 12) + 2)$$

TVC .. ADCC0.6-4 [TVC]
STC .. ADCC0.2-0 [STC]

Figure 38 Calculation of the ADC conversion time using full conversion

Sub conversions with reduced length need less ADC clock cycles. The conversion time for sub conversions is calculated with the formula shown in [Figure 39 “Calculation of the ADC conversion time using sub conversion” on Page 114](#).

$$t_{conv}[s] = \frac{1}{f_{CPU}[Hz]} \cdot (TVC \cdot (STC + SUBC) + 2)$$

TVC .. ADCC0.6-4 [TVC]
STC .. ADCC0.2-0 [STC]
SUBC .. ADCC1.2-0 [SUBC]

Figure 39 Calculation of the ADC conversion time using sub conversion

2.11.4.2 ADC Configuration

2.11.4.2.1 Reference- and Signal Voltage Selection

The input multiplexer of the ADC is used for selection of both reference voltage (see SFR bit ADCM.6-4 [RV2-0]) and signal voltage (see SFR bit ADCM.2-0 [CS2-0]).

2.11.4.2.2 Single ended / Differential Conversion

In order to obtain the highest accuracy, single-ended conversion must be used for channels 0 - 2. In single-ended conversion, only the positive input of the selected channel is used, the negative input is connected to GND internally. The high sensitivity inputs (channel 6 and 7) must be used in the differential mode.

2.11.4.2.3 Comparator Signal Inversion

The ADCC1.6 [CSI] inverts the polarity of the comparator with respect to the signal. By averaging two conversions with opposite polarity, the comparator offset is eliminated.

2.11.4.2.4 Channel Gain Selection

The ADCC1.5-4 [GAIN1-0] gain factor selection allows the selection of the sensitivity of the analog input channels 6 and 7. The gain is one for all other input channels

2.11.4.2.5 Full Conversion or Sub Conversion

The ADCC1.3 [FCnSC] allows the selection of a conversion of all bits of the code range (10 bits, full conversion) or of a reduced number of bits (sub conversion). The number of bits is chosen by the bits ADCC1.2-0 [SUBC]. All higher bits are taken from the result of the previous conversion. The ADC state machine automatically subtracts half of the sub conversion range from the result of the previous conversion. Therefore the signal values can vary between the value of the previous conversion minus half of the weight of the sub conversion range to the value of the previous conversion plus half of the weight of the sub conversion range.

2.11.4.2.6 Analog Offset Correction of the Wheatstone Bridge Signals

In order to use the full ADC input range to convert the sensor signals, it is desirable to perform a correction of the output voltage from the connected wheatstone bridge. The correction can be viewed as a constant voltage which is added to the wheatstone bridge output. The implementation takes advantage of the differential charge

redistribution structure of the ADC, by adding additional capacitor arrays for the offset correction. The analog offset correction performs two functions

1. Cancel the major part of the sensor's offset voltage.
2. Position the sensor signal so that it utilizes the full input range of the ADC.

It is also possible to operate the ADC with zero offset correction.

The bits ADCOFF.5-0 [OFF5-0] allow the selection of an analog offset correction to the analog input voltage. The offset is a function of the reference voltage, the bits ADCOFF.5-0 [OFF5-0] parameter and a fixed gain factor of 1/50. The number format is 2's complement.

The offset value can be calculated with the formula shown in [Figure 40 “ADC offset voltage calculation” on Page 115](#).

$$U_{offset} = \frac{U_{ref}}{32} \cdot \frac{goff}{50} \cdot \left(\sum_{i=0}^4 2^i \cdot OFF(i) - (2^5 \cdot OFF(5)) \right)$$

OFF ..ADCOFF.5-0

Figure 40 ADC offset voltage calculation

The offset gain factor (goff) is determined by the selection of input channel (ADCM.2-0[CS]) and input gain (ADCC1.5-4[GAIN]) as described in [Table 18 “Selection of the Gain Factor” on Page 109](#). The reference voltage U_{ref} is the input voltage of the selected reference voltage source (ADCM.6-4[RV2-0]).

2.11.4.3 ADC Conversion Result

The ADC conversion result ($result_{code}$) data format is binary unsigned and stored in ADCH and ADCL.

The type of single ended/differential conversion is selected with bit ADCC1.7[SeDC]. The result of a single ended/differential conversion can be calculated with the formulas shown in [Figure 41 “Calculation of single ended conversion” on Page 115](#) and [Figure 42 “Calculation of differential conversion” on Page 115](#). The truncation function takes the integer value of the calculation. The gain factor is obtained from [Table 18 “Selection of the Gain Factor” on Page 109](#). $U_{channel}$ is the voltage at the selected input channel. For U_{offset} voltage calculation see [Figure 40 “ADC offset voltage calculation” on Page 115](#).

$$result_{code} = trunc \left(2^{10} \cdot gain \cdot \frac{U_{channel} + U_{offset}}{U_{ref}} \right)$$

Figure 41 Calculation of single ended conversion

$$result_{code} = 2^9 + trunc \left(2^9 \cdot gain \cdot \frac{U_{channel} + U_{offset}}{U_{ref}} \right)$$

Figure 42 Calculation of differential conversion

Output Status Bits

The ADC provides separate status bits for underflow and overflow after the conversion. The output value remains at the maximum value in case of an overflow, and at the minimum value in case of an underflow. All status bits are defined in ADCS and are active high.

2.11.5 Register Description

Table 19 Registers Overview

Register Short Name	Register Long Name	Offset Address	Wakeup Value	Page Number
ADCM	ADC Mode Register	D2 _H	77 _H	120
ADCS	ADC Status Register	D3 _H	00 _H	122
ADCDL	ADC Result Register low byte	D4 _H	00 _H	119
ADCDH	ADC Result Register high byte	D5 _H	00 _H	119
ADCOFF	ADC Input Offset c-network configuration	DA _H	00 _H	121
ADCC0	ADC Configuration Register 0	DB _H	00 _H	116
ADCC1	ADC Configuration Register 1	DC _H	00 _H	118

ADC Configuration Register 0

ADCC0	Offset	Wakeup Value	Reset Value
ADC Configuration Register 0	DB _H	00 _H	00 _H

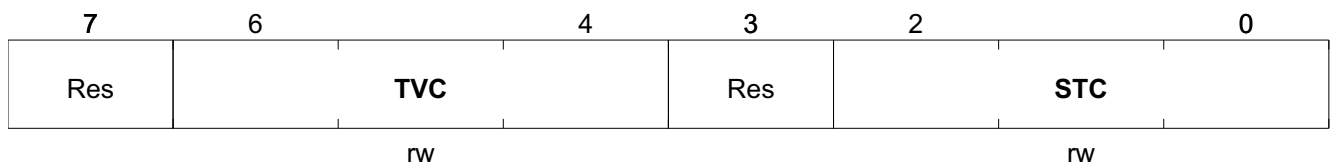

Field	Bits	Type	Description
Res	7		Reserved
TVC	6:4	rw	Internal Clock Divider 000 _B Divider factor 8 001 _B Divider factor 10 010 _B Divider factor 12 011 _B Divider factor 14 100 _B Divider factor 16 101 _B Divider factor 18 110 _B Divider factor 20 111 _B Divider factor 1
Res	3		Reserved

Functional Description

Field	Bits	Type	Description
STC	2:0	rw	Sample Time Adjustment 000 _B 2 periods of ADC clock 001 _B 4 periods of ADC clock 010 _B 5 periods of ADC clock 011 _B 6 periods of ADC clock 100 _B 7 periods of ADC clock 101 _B 8 periods of ADC clock 110 _B 12 periods of ADC clock 111 _B 16 periods of ADC clock

ADC Result Register High Byte

ADCDH	Offset	Wakeup Value	Reset Value
ADC Result Register high byte	D5 _H	00 _H	00 _H

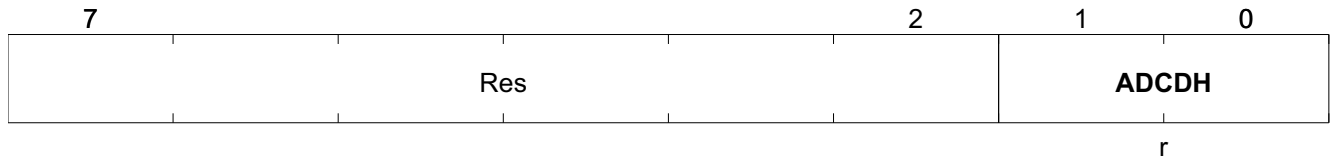

Field	Bits	Type	Description
Res	7:2		Reserved
ADCDH	1:0	r	ADC conversion data bit 9 - bit 8

ADC Result Register Low Byte

ADC DL	Offset	Wakeup Value	Reset Value
ADC Result Register low byte	D4 _H	00 _H	00 _H

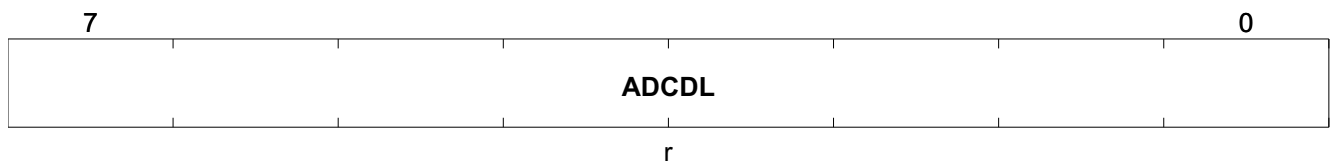

Field	Bits	Type	Description
ADC DL	7:0	r	ADC conversion data bit 7 - bit 0

ADC Mode Register

ADCM	Offset	Wakeup Value	Reset Value
ADC Mode Register	D2 _H	77 _H	77 _H

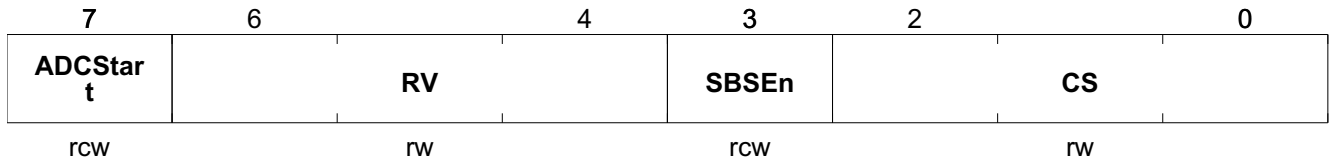

Field	Bits	Type	Description
ADCStart	7	rcw	ADC conversion start 0 _B Idle 1 _B ADC starts conversion. Bit is cleared automatically
RV	6:4	rw	Reference voltage selection 000 _B Battery sensor signal (channel 0) 001 _B Temperature sensor signal (channel 1) 010 _B Standard differential analog interface AMUX1, AMUX2 (channel 2) 011 _B Internal reference voltage (channel 3) 100 _B V _{reg} Sensor signal (channel 4) 101 _B Wheatstone bridge supply - VDD _{sens} (channel 5) 110 _B Reserved 111 _B Reserved
SBSEn	3	rcw	Sensor bridge supply enable 0 _B Sensor bridge supply disabled 1 _B Sensor bridge supply enabled. Bit is cleared automatically
CS	2:0	rw	Analog channel selection 000 _B Battery sensor signal (channel 0) 001 _B Temperature sensor signal (channel 1) 010 _B Standard differential analog interface AMUX1, AMUX2 (channel 2) 011 _B Internal reference voltage (channel 3) 100 _B V _{reg} Sensor signal (channel 4) 101 _B Wheatstone bridge supply - VDD _{sens} (channel 5) 110 _B Differential high sensitivity input 1 (channel 6) 111 _B Differential high sensitivity input 2 (channel 7)

ADC Input Offset c-Network Configuration

ADCOFF	Offset	Wakeup Value	Reset Value
ADC Input Offset c-network configuration	DA _H	00 _H	00 _H

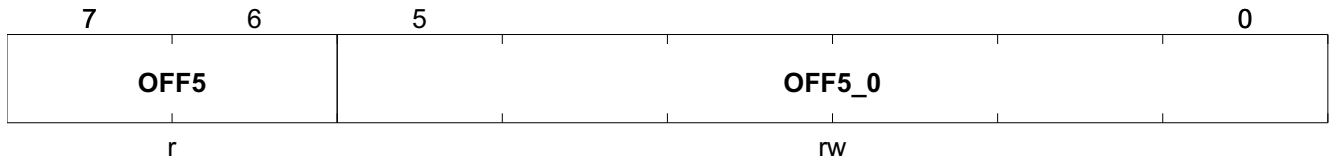

Field	Bits	Type	Description
OFF5	7:6	r	ADC Input offset compensation copy of bit 5 These two bits are set automatically by hardware and always have the same value as OFF.5. This is needed for correct representation of 2's complement for all 8 bits of this register.
OFF5_0	5:0	rw	ADC Input offset compensation network selection The offset voltage can be calculated with the offset value (OFF) using formula Figure 40 "ADC offset voltage calculation" on Page 115 . The number format of the offset value (OFF) is 2's complement. 000000 _B 00 _H 000001 _B 01 _H 000010 _B 02 _H ... 011110 _B 1E _H 011111 _B 1F _H 100000 _B -20 _H 100001 _B -1F _H 100010 _B -1E _H ... 111110 _B -02 _H 111111 _B -01 _H

ADC Status Register

ADCS	Offset	Wakeup Value	Reset Value
ADC Status Register	D3_H	00_H	00_H

7	6	5	4	3	2	1	0
Res	SARSATL	SARSATH	CL000	CG3FF	Res	SAMPLE	BUSY
	r	r	r	r		r	r

Field	Bits	Type	Description
Res	7		Reserved
SARSATL	6	r	Negative saturation of SAR
SARSATH	5	r	Positive saturation of SAR
CL000	4	r	Saturation of c-net control word 000 _H saturation of c-net control word
CG3FF	3	r	Saturation of c-net control word 3FF _H saturation of c-net control word
Res	2		Reserved
SAMPLE	1	r	Sample/Hold 0 _B hold 1 _B sample
BUSY	0	r	Busy 0 _B Conversion finished 1 _B Conversion running

2.12 16 bit CRC (Cyclic Redundancy Check) Generator/Checker

CRC is a powerful method to detect errors in data packets that have been transmitted over a distorted connection. The CRC Generator/Checker divides each byte of a transmitted/received data packet by a polynomial, leaving the remainder, which represents the checksum. The CRC Generator/Checker uses the 16-bit CCITT polynomial $1021_H (x^{16}+x^{12}+x^5+1)$. The 16-bit start value is determined by SFR CRC0 and SFR CRC1.

The CRC Generator/Checker can process 8-bit parallel and/or serial data. **Figure 43** gives an overview over the CRC Generator/Checker. A CRC generation and CRC checking example can be found in **Figure 44**.

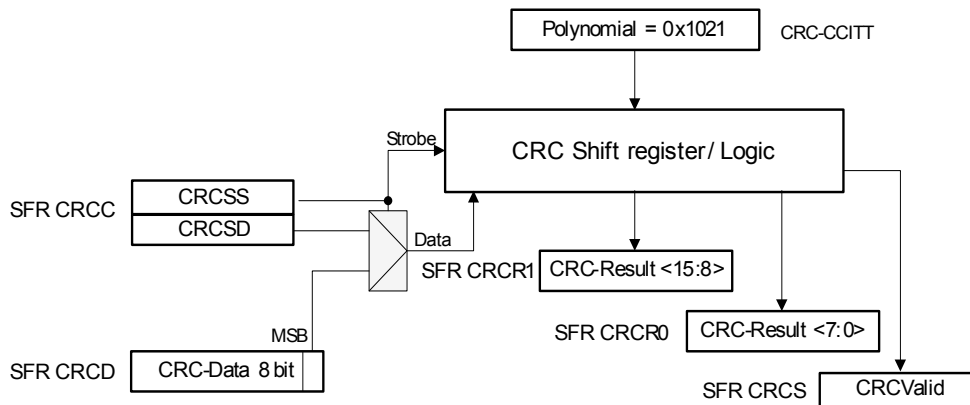

Figure 43 CRC (Cyclic Redundancy Check) Generator/Checker

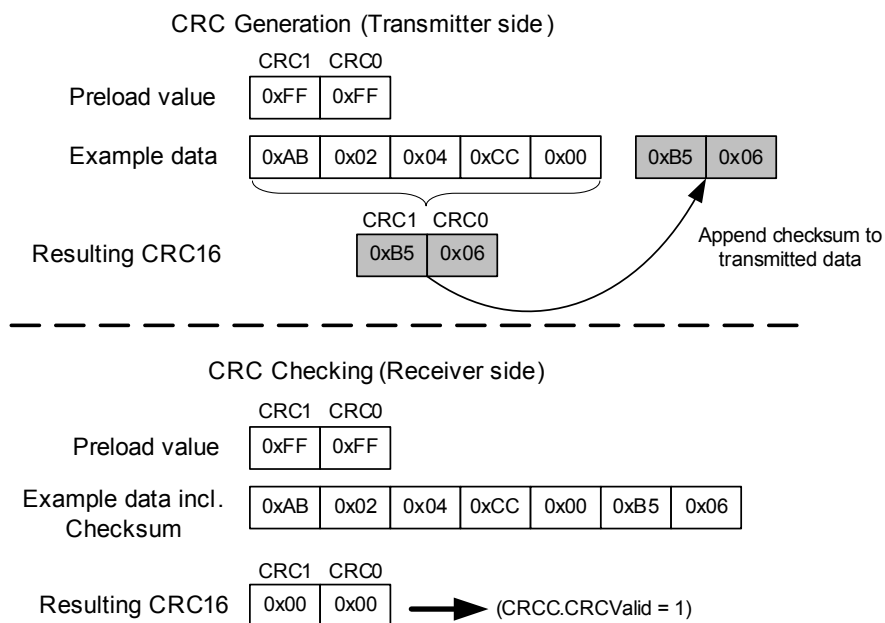

Figure 44 CRC (Cyclic Redundancy Check) Generator/Checker example

2.12.1 Byte-aligned CRC Generation

CRC generation is done by executing the following steps:

- The CRC shift register has to be initialized by writing a start value to both SFR CRC0 and SFR CRC1. If the CRC shift register is not initialized, the default value is 00_H .
- The data bytes which are used for the CRC generation have to be shifted one after the other into the SFR CRCD. The process of CRC generation is automatically invoked when data bytes are written to the SFR CRCD.

- The resulting checksum is available in the CRC result register SFR CRC0 and SFR CRC1 after the last data byte has been processed.

2.12.2 Byte-aligned CRC Checking

CRC checking is done by executing the following steps:

- The CRC shift register has to be initialized by writing the initialization value of the CRC generation process to both SFR CRC0 and SFR CRC1.
- The data bytes which should be checked have to be shifted one after the other into the SFR CRCD. It is important that the order (MSB-LSB) is the same as it was during CRC generation. The process of CRC checking is automatically invoked when data bytes are written to the SFR CRCD.
- The 16-bit CRC value is written to the SFR CRCD beginning with the high byte after processing all user data.
- The SFR Bit CRCC.1[CRCCValid] indicates the correctness of the CRC calculation after the last data byte has been processed and both SFR CRC0 and SFR CRC1 are 0.

2.12.3 Serial bit stream CRC Generation/Checking

The CRC Generator/Checker features an additional serial mechanism to perform CRC generation and checking of non-byte-aligned data streams. In this case SFR Bit CRCC.5[CRCSS] and SFR Bit CRCC.6[CRCS D] are used instead of SFR CRCD.

The data stream is written bit-by-bit into SFR Bit CRCC.6[CRCS D]. Each bit is processed by forcing the flag SFR Bit CRCC.5[CRCSS] to 1_B.

The following figure shows an example of the usage of SFR Bit CRCC.5[CRCSS] and SFR Bit CRCC.6[CRCS D].

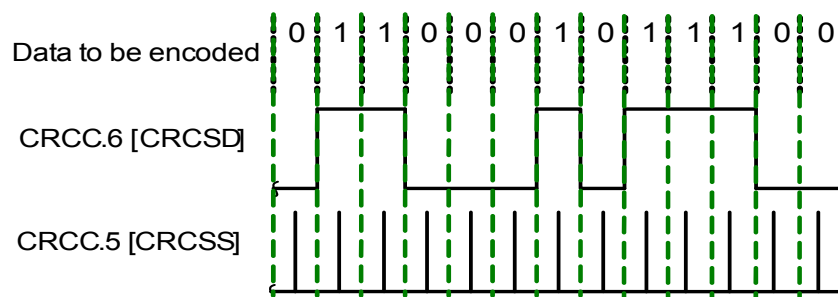

Figure 45 Example of Serial CRC Generation/checking

Note: The serial and byte-aligned generation/checking mechanism is interchangeable within the same generation/checking process. For example, if a data packet consists of 18 bits, then 16 bits can be processed byte-aligned via SFR CRCD and the two remaining bits can be processed bit-aligned by using SFR Bit CRCC.5[CRCSS] and SFR Bit CRCC.6[CRCS D].

2.12.4 Register Description

Table 20 Registers Overview

Register Short Name	Register Long Name	Offset Address	Wakeup Value	Page Number
CRCC	CRC Control Register	A9 _H	02 _H	125
CRCD	CRC Data Register	AA _H	00 _H	126
CRC0	CRC Shift Register low byte	AC _H	00 _H	126
CRC1	CRC Shift Register high byte	AD _H	00 _H	127

CRC Control Register

CRCC	Offset	Wakeup Value	Reset Value
CRC Control Register	A9 _H	02 _H	02 _H

7	6	5	4	2	1	0
Res	CRCS rw	CRCD rw	Res	Res	CRCValid r	Res

Field	Bits	Type	Description
Res	7		Reserved
CRCS	6	rw	CRC Serial Data
CRCD	5	rw	CRC Serial Data Strobe Use CRCD to serial strobe data bit CRCS into CRC encoding/decoding procedure. 0 _B No calculation cycle is done 1 _B One calculation cycle is done with every write access to CRCS or CRCD
Res	4:2		Reserved
CRCValid	1	r	CRC Valid Is set by hardware on valid CRC results, that means all CRC-bits are 0 0 _B CRC result invalid (at least one bit in CRC0 or CRC1 is 1 _B) 1 _B CRC result valid (all bits in CRC0 and CRC1 are 0 _B)
Res	0		Reserved

CRC Data Register

CRC0 CRC Data Register	Offset AA _H	Wakeup Value 00 _H	Reset Value 00 _H
----------------------------------	----------------------------------	--	---------------------------------------

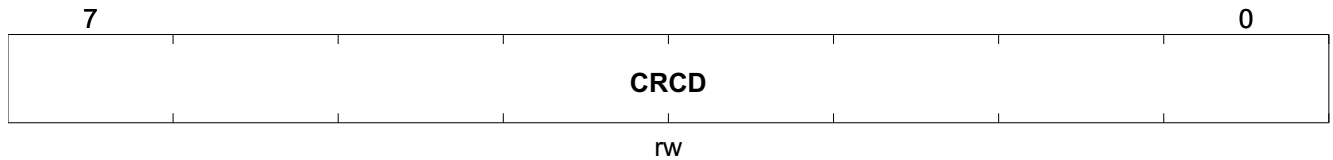

Field	Bits	Type	Description
CRC0	7:0	rw	CRC Data Register

CRC Shift Register low byte

CRC0 CRC Shift Register low byte	Offset AC _H	Wakeup Value 00 _H	Reset Value 00 _H
--	----------------------------------	--	---------------------------------------

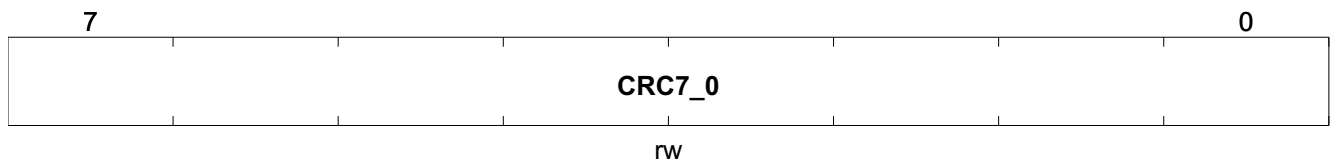

Field	Bits	Type	Description
CRC7_0	7:0	rw	CRC Shift Register bit 7 down to bit 0

CRC Shift Register high byte

CRC1	Offset	Wakeup Value	Reset Value
CRC Shift Register high byte	AD _H	00 _H	00 _H

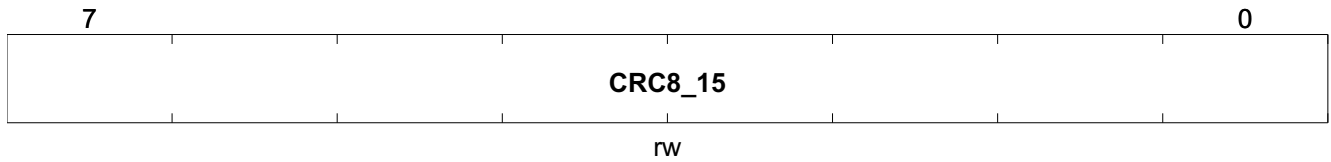

Field	Bits	Type	Description
CRC8_15	7:0	rw	CRC Shift Register bit 15 down to bit 8

2.13 8 bit Pseudo Random Number Generator

For many applications, a pseudo-random number generator is needed, e.g. to vary the interval period between transmissions. For this purpose, a Maximum Length linear Feedback Shift Register (MLFSR) is available as a hardware unit. A user-defined start value (except 00_H) can be written to SFR RNGD. The default value after startup is 55_H. With every read access to SFR RNGD a new pseudo-random number is generated.

2.13.1 Register Description

Random Number Generator Data Register

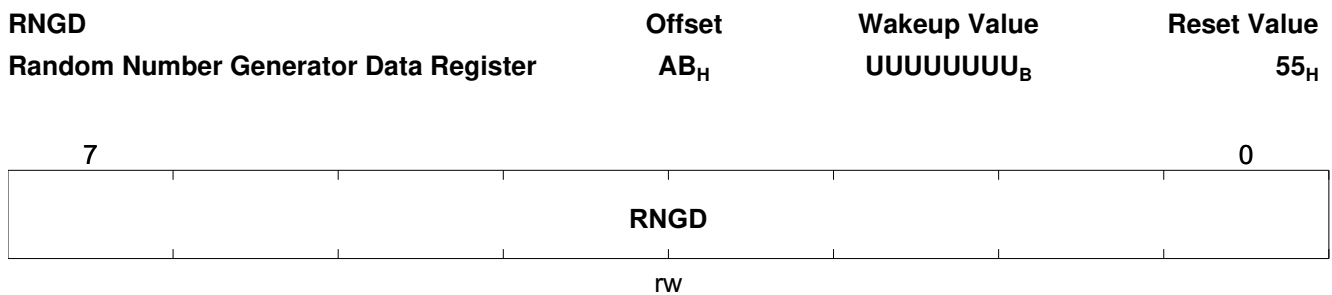

Field	Bits	Type	Description
RNGD	7:0	rw	Random Number Generator Data Register

2.14 Timers

The PMA51xx comprises four independent 16-bit timers. Timers 0/1 operate as up-counters, and Timers 2/3 operate as down-counters.

2.14.1 Timer 0 and Timer 1

Timer/Counter 0 and 1 are fully compatible with Timer/Counter 0 and 1 of the Standard 8051 microcontroller. Timer 0/1 operate as up-counters and use the selected system clock divided by 6.

2.14.1.1 Basic Timer Operations

The external inputs PP1 and PP9 can be programmed to function as a gate for Timer/Counters 0 and 1 to facilitate pulse-width measurements. Each timer consists of two 8-bit registers (TH0 and TL0 for Timer/Counter 0, TH1 and TL1 for Timer/Counter 1) that may be combined to one timer configuration depending on the mode that is established. The functions of the timers are controlled by two SFRs, TCON and TMOD. The operating modes are described and shown for Timer 0. If not explicitly noted, this applies also to Timer 1.

Setting the SFR bit TCON.4[TR0] (respectively SFR bit TCON.6[TR1]) starts Timer 0 (resp. Timer 1). It counts using the selected clock (see SFR TMOD) until the timer has an overflow. SFR bit TCON.5[TF0] (resp. SFR bit TCON.7[TF1]) is set.

If the selected timer mode uses timer reload, then the timer is automatically reloaded and restarted.

If the selected timer mode does not use timer reload, the timer is stopped and SFR bit TCON.4[TR0] (resp. SFR bit TCON.6[TR1]) is cleared.

2.14.1.2 Timer Modes

Timer/Counter 0 and 1 can be used in the following four operating modes:

- Mode 0: 8 bit timer/counter with a divide-by-32 prescaler (13 bit timer register: 8 bit + 5 bit prescaler)
- Mode 1: 16 bit timer/counter
- Mode 2: 8 bit timer/counter with 8 bit auto-reload
- Mode 3: Timer/Counter 0 is configured as one 8 bit timer/counter and one 8 bit counter counting machine cycles. Timer/counter 1 in this mode holds its count. The effect is the same as setting TR1 = 0.

2.14.1.2.1 Timer/Counter 0/1 - Mode 0

Figure 46 “Timer/Counter 0, Mode 0, 13-Bit Timer/Counter” on Page 129 shows the Mode 0 operation.

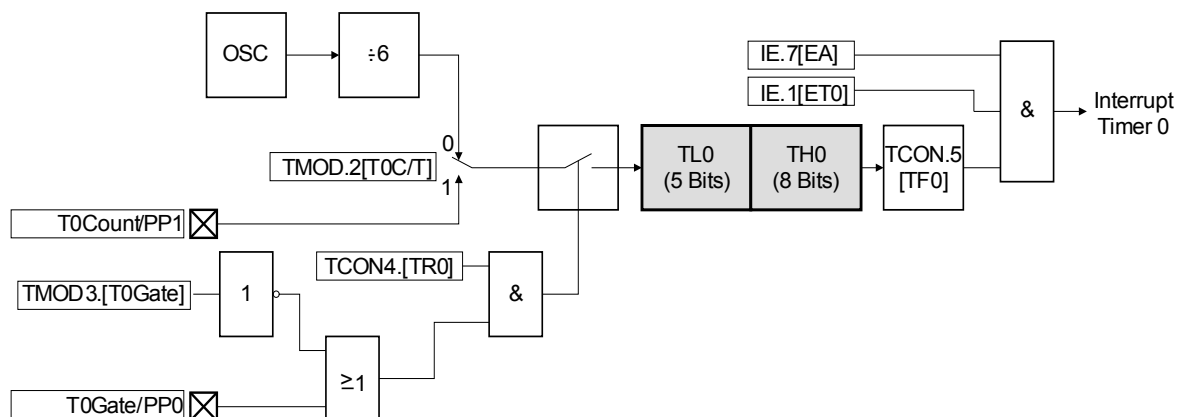

Figure 46 Timer/Counter 0, Mode 0, 13-Bit Timer/Counter

2.14.1.2.2 Timer/Counter 0/1 - Mode 1

Mode 1 is equal to Mode 0 but in Mode 1, the timer register is running with all 16 bits.

2.14.1.2.3 Timer/Counter 0/1 - Mode 2

Mode 2 configures the Timer register as an 8-bit counter in TL0 (resp. TL1) with automatic reload, as shown in [Figure 47 “Timer/Counter 0, Mode 2: 8-bit Timer/Counter with auto-reload” on Page 130](#). Overflow from TL0 (resp. TL1) not only sets TCON.5 [TF0] (resp. TCON.7 [TF1]), but also reloads TL0 (resp. TL1) with the contents of TH0 (resp. TH1), which is preset by software. The reload leaves TH0 (resp. TH1) unchanged.

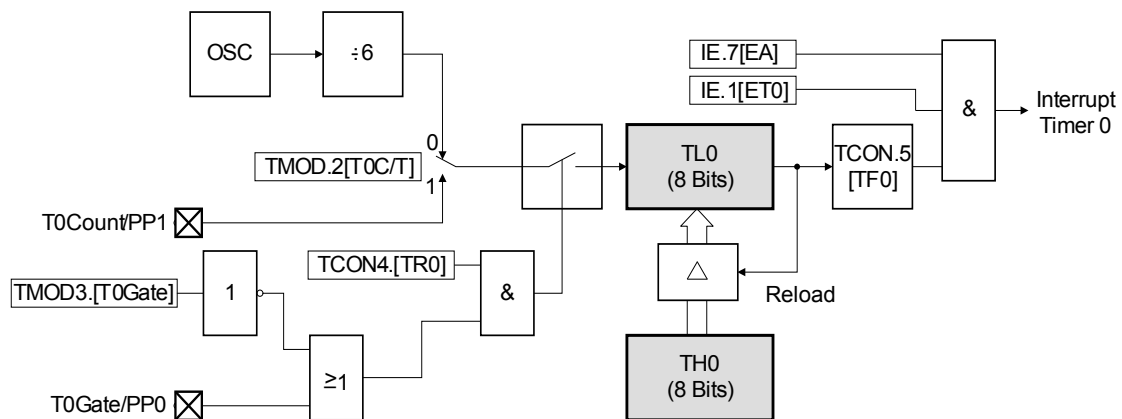

Figure 47 Timer/Counter 0, Mode 2: 8-bit Timer/Counter with auto-reload

2.14.1.2.4 Timer/Counter 0/1 - Mode 3

Mode 3 has different effects on Timer 0 and Timer 1. Timer 1 in Mode 3 simply holds its count. The effect is the same as setting TCON.6 [TR1]=0. Timer 0 establishes TL0 and TH0 as two separate counters ([Figure 48 “Timer/Counter 0, Mode 3: Two 8-bit Timers/Counters” on Page 131](#)). TL0 uses the Timer 0 control bits: TMOD.2 [T0C/T], TMOD.3 [T0Gate], TCON.4 [TR0], TCON.5 [TF0] and the pin status of PP0. TH0 is locked into a timer function (counting machine cycles) and takes over the use of TCON.6 [TR1] and TCON.7 [TF1] from Timer 1. Thus, TH0 now controls the Timer 1 interrupt. Mode 3 is provided for applications requiring an extra 8-bit timer or counter. When Timer 0 is in Mode 3, Timer 1 can be turned on and off by switching it out of and into its own Mode 3, or in fact, in any application not requiring an interrupt from Timer 1 itself.

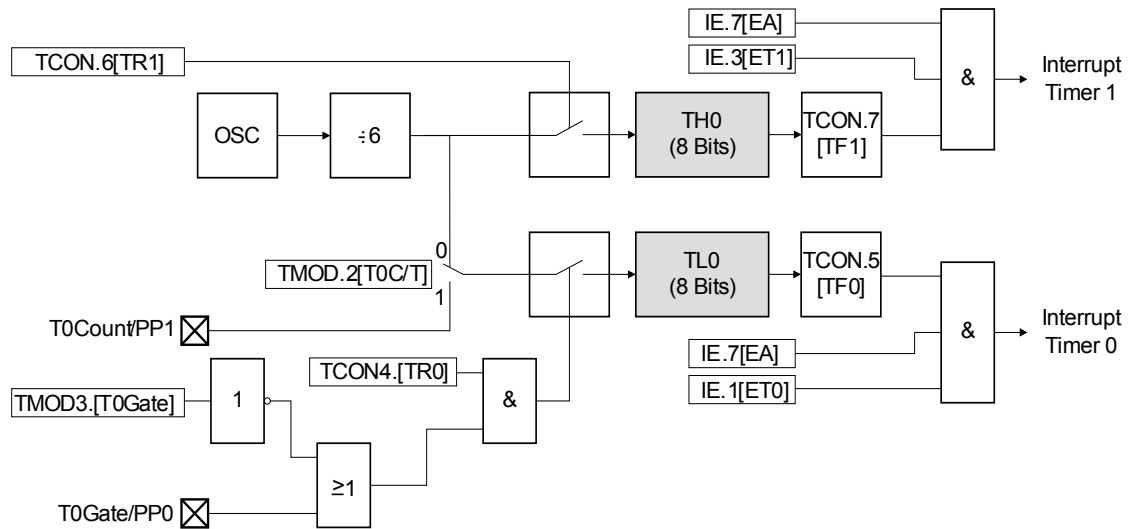

Figure 48 Timer/Counter 0, Mode 3: Two 8-bit Timers/Counters

2.14.1.3 Timer/Counter 0/1 Interrupt support

This module supports interrupt generation on overflow of Timer/Counter 0 as well as Timer/Counter 1. In addition to these timer/counter interrupts, two external interrupts are handled by this unit (ref. to standard 8051).

On overflow of the up counting timer/counter from all 1_B to all 0_B, the flag TCON.5 [TF0] or TCON.7 [TF1] is set by hardware. These flags acts as interrupt request flags. A 1_B indicates a pending interrupt request. These flags are cleared by hardware as on standard 8051 when the corresponding interrupt vector has been fetched by the CPU.

2.14.1.4 Register Description

Table 21 Registers Overview

Register Short Name	Register Long Name	Offset Address	Wakeup Value	Page Number
TCON	Timer Control Register Timer 0/1	88 _H	00 _H	132
TMOD	Timer Mode Register Timer 0/1	89 _H	00 _H	135
TL0	Timer 0 Register low byte	8A _H	00 _H	134
TL1	Timer 1 Register low byte	8B _H	00 _H	134
TH0	Timer 0 Register high byte	8C _H	00 _H	133
TH1	Timer 1 Register high byte	8D _H	00 _H	133

Timer Control Register Timer 0/1

TCON							
Timer Control Register Timer 0/1							
				Offset	Wakeup Value		Reset Value
				88 _H	00 _H		00 _H
7	6	5	4	3	2	1	0
TF1	TR1	TF0	TR0	IE1	IT1	IE0	IT0
rw	rw	rw	rw	rw	rw	rw	rw

Field	Bits	Type	Description
TF1	7	rw	Timer 1 Overflow Flag This flag is set on timer overflow and automatically cleared by hardware if the interrupt service routine is entered. In polling mode this bit has to be cleared by software.
TR1	6	rw	Timer 1 Run Control Bit 0 _B Stop Timer 1 / Timer 1 does not run 1 _B Start Timer 1 / Timer 1 runs
TF0	5	rw	Timer 0 Overflow Flag This flag is set on timer overflow and automatically cleared by hardware if the interrupt service routine is entered. In polling mode this bit has to be cleared by software.
TR0	4	rw	Timer 0 Run Control Bit 0 _B Stop Timer 0 / Timer 0 does not run 1 _B Start Timer 0 / Timer 0 runs
IE1	3	rw	Interrupt 1 Request Flag This is the interrupt request flag for external interrupt 1 (PP7) 0 _B Interrupt 1 has not been triggered 1 _B Interrupt 1 has been triggered
IT1	2	rw	Interrupt 1 Type Control bit 0 _B Interrupt 1 is triggered by a low level on PP7 1 _B Interrupt 1 is triggered by a falling edge on PP7
IE0	1	rw	Interrupt 0 Request Flag This is the interrupt request flag for external interrupt 0 (PP9) 0 _B Interrupt 0 has not been triggered 1 _B Interrupt 0 has been triggered
IT0	0	rw	Interrupt 0 Type Control bit 0 _B Interrupt 0 is triggered by a low level on PP9 1 _B Interrupt 0 is triggered by a falling edge on PP9

Timer 0 Register high byte

TH0	Offset	Wakeup Value	Reset Value
Timer 0 Register high byte	8C _H	00 _H	00 _H

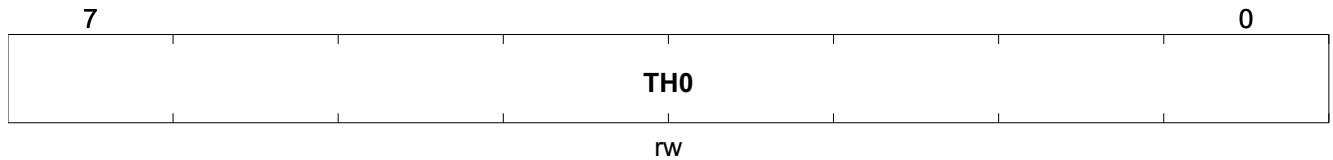

Field	Bits	Type	Description
TH0	7:0	rw	Timer 0 Register high byte

Timer 1 Register high byte

TH1	Offset	Wakeup Value	Reset Value
Timer 1 Register high byte	8D _H	00 _H	00 _H

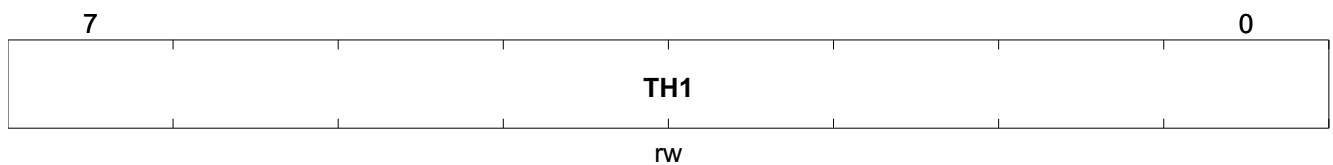

Field	Bits	Type	Description
TH1	7:0	rw	Timer 1 Register high byte

Timer 0 Register low byte

TL0	Offset	Wakeup Value	Reset Value
Timer 0 Register low byte	8A _H	00 _H	00 _H

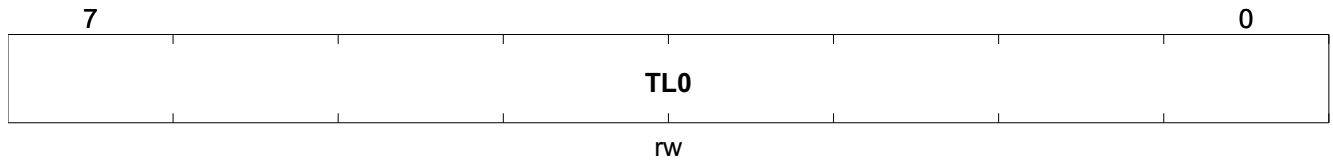

Field	Bits	Type	Description
TL0	7:0	rw	Timer 0 Register low byte

Timer 1 Register low byte

TL1	Offset	Wakeup Value	Reset Value
Timer 1 Register low byte	8B _H	00 _H	00 _H

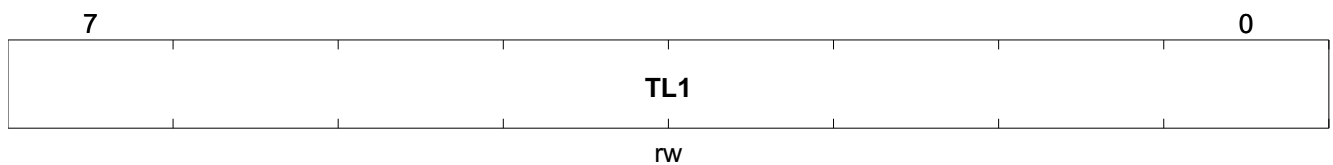

Field	Bits	Type	Description
TL1	7:0	rw	Timer 1 Register low byte

2.14.2 Timer 2 and Timer 3

Timer 2 and Timer 3 operate as down-counters. The clock source and the timer mode can be selected using SFR TMOD2.

2.14.2.1 Basic Timer Operations

Setting the SFR Bit TCON2.0[T2Run] (respectively SFR Bit TCON2.4[T3Run]) starts Timer 2 (resp. Timer 3). It counts using the selected clock (see SFR TMOD2) until the timer is elapsed. SFR Bit TCON2.1[T2Full] (resp. SFR Bit TCON2.5[T3Full]) is set.

If the selected timer mode used timer reload, then the timer is automatically reloaded and restarted on underrun. If the selected timer mode didn't use timer reload, the timer is stopped on underrun and SFR Bit TCON2.0[T2Run] (resp. SFR Bit TCON2.4[T3Run]) is cleared.

2.14.2.2 Timer Modes

Depending on the setting of the 3 bits of SFR Bit TMOD2.2 0[TM2-0], there are 8 timer modes selectable with Timer 2 and Timer 3.

2.14.2.2.1 Timer 2/3 - Mode 0

Comprises:

- 16-bit timer with reload

The timer unit is configured as a 16-bit reloadable timer. SFR TL2 and SFR TH2 hold the start value. If SFR Bit TCON2.0[T2Run] is set, the timer starts counting down. SFR Bit TCON2.1[T2Full] is set when the timer is elapsed (underflow from 00_H to FF_H). The timer value is reloaded from SFR TL3 and SFR TH3, and the timer is restarted automatically. SFR Bit TCON2.1[T2Full] has to be reset by software. It is not cleared on read access.

Note: In this mode, both SFR Bit TCON2.4[T3Run] and SFR Bit TCON2.5[T3Full] are not used.

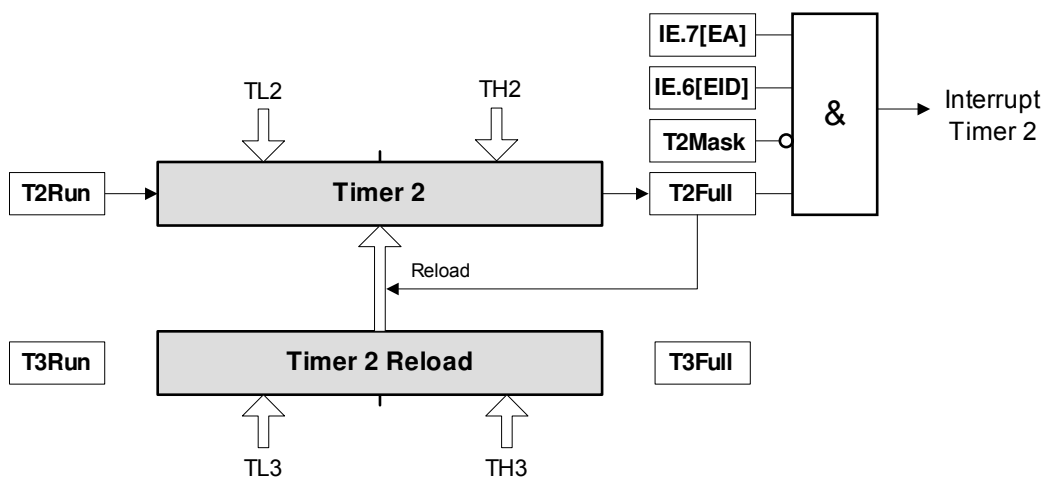

Figure 49 Timer 2/3 - Mode 0

2.14.2.2.2 Timer 2/3 - Mode 1

Comprises:

- 16-bit timer without reload
- 8-bit timer with reload and bit rate strobe signal for RF Transmitter

Timer 2 operates as a 16-bit timer with start value in SFR TL2 and SFR TH2, timer run bit SFR Bit TCON2.0[T2Run] and timer elapsed indicator SFR Bit TCON2.1[T2Full]. If the timer elapses, it stops, sets SFR Bit TCON2.1[T2Full], and resets the timer run bit SFR Bit TCON2.0[T2Run].

Timer 3 sets up a reloadable 8-bit timer holding the startup value in SFR TL3, timer reload value in SFR TH3, timer run bit in SFR Bit TCON2.4[T3Run], and timer elapsed indicator in SFR Bit TCON2.5[T3Full].

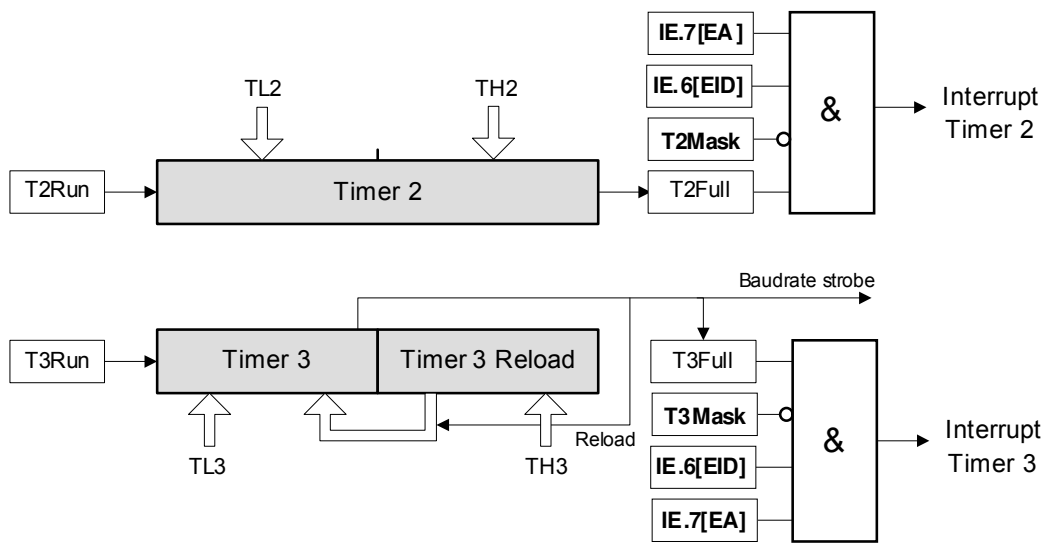

Figure 50 Timer 2/3 - Mode 1

2.14.2.2.3 Timer 2/3 - Mode 2

Comprises:

- 8-bit timer with reload
- 8-bit timer with reload and bit rate strobe signal for RF Transmitter

Timer 2 sets up a reloadable 8-bit timer holding the start value SFR TL2, timer reload value SFR TH2, timer run bit SFR Bit TCON2.0[T2Run], and timer elapsed indicator SFR Bit TCON2.1[T2Full].

Timer 3 sets up a reloadable 8-bit timer holding the start value SFR TL3, timer reload value SFR TH3, timer run bit SFR Bit TCON2.4[T3Run], and timer elapsed indicator SFR Bit TCON2.5[T3Full].

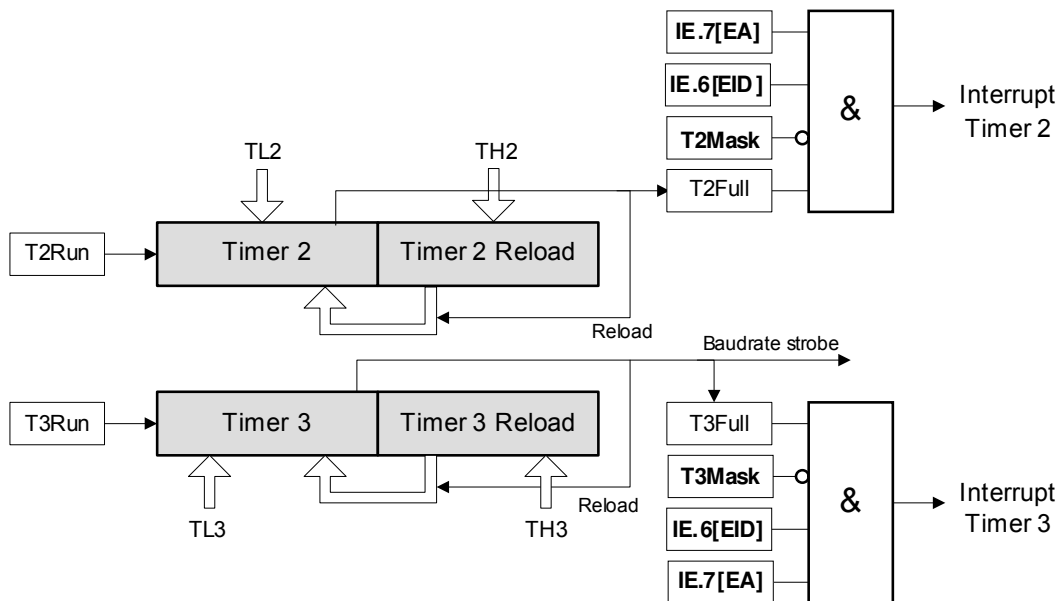

Figure 51 Timer 2/3 - Mode 2

2.14.2.2.4 Timer 2/3 - Mode 3

Comprises:

- 8-bit timer without reload (1)
- 8-bit timer without reload (2)
- 8-bit timer with reload and bit rate strobe signal for RF Transmitter

Timer 2 (1) utilizes SFR TL2 as starting value and T2Full as timer elapsed flag. Setting SFR Bit TCON2.0[T2Run] starts the timer, and SFR Bit TCON2.1[T2Full] is set when the timer is elapsed. SFR Bit TCON2.0[T2Run] is reset automatically if the timer elapses.

Timer 2 (2) utilizes SFR TH2 as starting value and SFR Bit TCON2.5[T3Full] as timer elapsed flag. Setting SFR Bit TCON2.4[T3Run] starts the timer, and SFR Bit TCON2.5[T3Full] is set when the timer is elapsed. SFR Bit TCON2.4[T3Run] is reset automatically if the timer elapses.

Timer 3 operates exclusively as an 8-bit bit rate timer for Manchester coding. Therefore the timer needs neither a run nor an elapsed bit. It is started automatically when the timer mode is set.

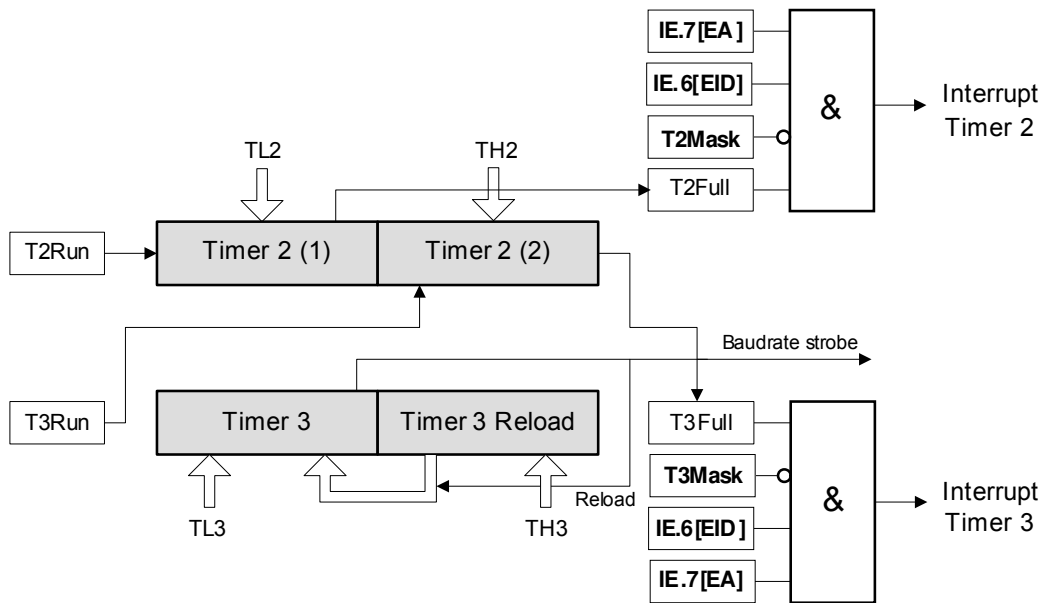

Figure 52 Timer 2/3 - Mode 3

2.14.2.2.5 Timer 2/3 - Mode 4

Comprises:

- 16-bit timer with reload and bit rate strobe signal for RF Transmitter

The timer unit is configured as a 16-bit reloadable timer. SFR TL3 and SFR TH3 hold the start value. As soon as SFR Bit TCON2.4[T3Run] is set, the timer starts counting. SFR Bit TCON2.5[T3Full] is set when the timer is elapsed. The timer value is reloaded from SFR TL2 and SFR TH2 and the timer is restarted automatically. SFR Bit TCON2.5[T3Full] has to be reset by software. It is not cleared on read-access.

Note: In this mode, both SFR Bit TCON2.0[T2Run] and SFR Bit TCON2.1[T2Full] are not used.

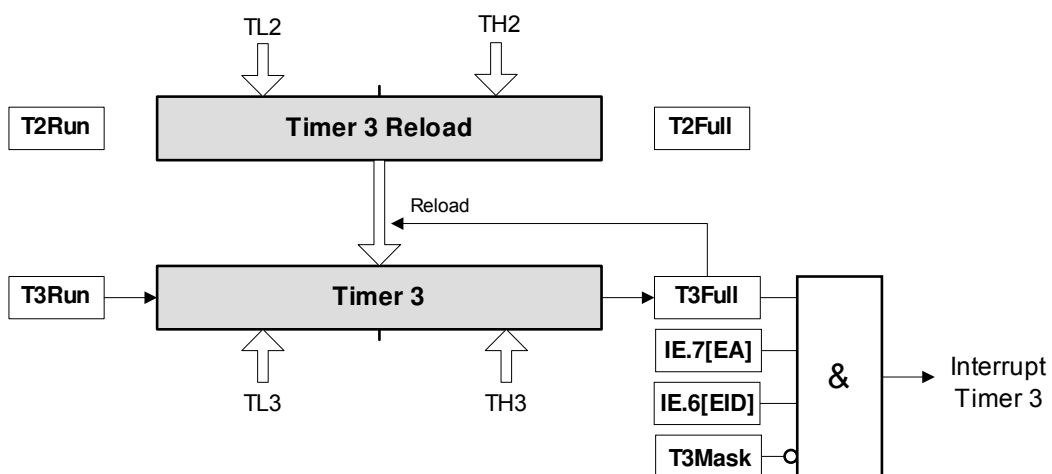

Figure 53 Timer 2/3 - Mode 4

2.14.2.2.6 Timer 2/3 - Mode 5

Comprises:

- 8-bit timer with reload
- 16-bit timer without reload and bit rate strobe signal for RF Transmitter

Timer 2 sets up a reloadable 8-bit timer holding the start value in SFR TL2, timer reload value in SFR TH2, timer run bit SFR Bit TCON2.0[T2Run], and timer elapsed indicator in SFR Bit TCON2.1[T2Full].

Timer 3 operates as a 16-bit timer with the start value in SFR TL3 and SFR TH3, timer run bit SFR Bit TCON2.4[T3Run], and timer elapsed indicator SFR Bit TCON2.5[T3Full]. If the timer elapses, the timer stops SFR Bit TCON2.5[T3Full] is set, and the timer run bit SFR Bit TCON2.4[T3Run] is reset.

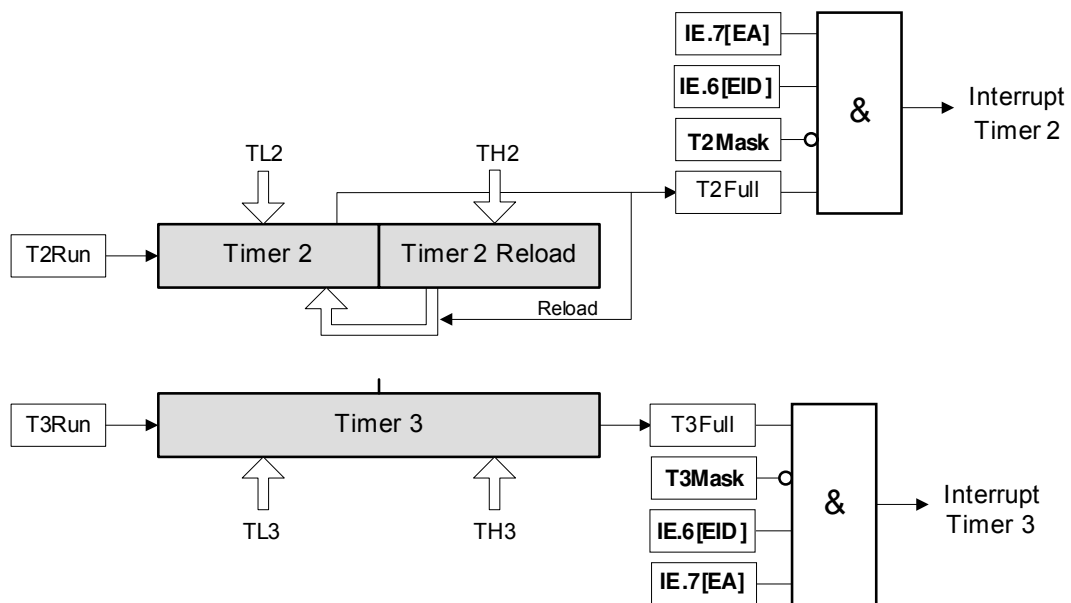

Figure 54 Timer 2/3 - Mode 5

2.14.2.2.7 Timer 2/3 - Mode 6

Comprises:

- 16-bit timer without reload
- 16-bit timer without reload and bit rate strobe signal for RF Transmitter

Timer 2 operates as a 16-bit timer with the start value in SFR TL2 and SFR TH2, timer run bit SFR Bit TCON2.0[T2Run], and timer elapsed indicator SFR Bit TCON2.1[T2Full]. If the timer is elapsed the timer is stopped, SFR Bit TCON2.1[T2Full] is set, and the timer run bit SFR Bit TCON2.0[T2Run] is reset.

Timer 3 operates as a 16-bit timer with the start value in SFR TL3 and SFR TH3, timer run bit SFR Bit TCON2.4[T3Run], and timer elapsed indicator SFR Bit TCON2.5[T3Full]. If the timer elapses, the timer stops, SFR Bit TCON2.5[T3Full] is set, and the timer run bit SFR Bit TCON2.4[T3Run] is reset.

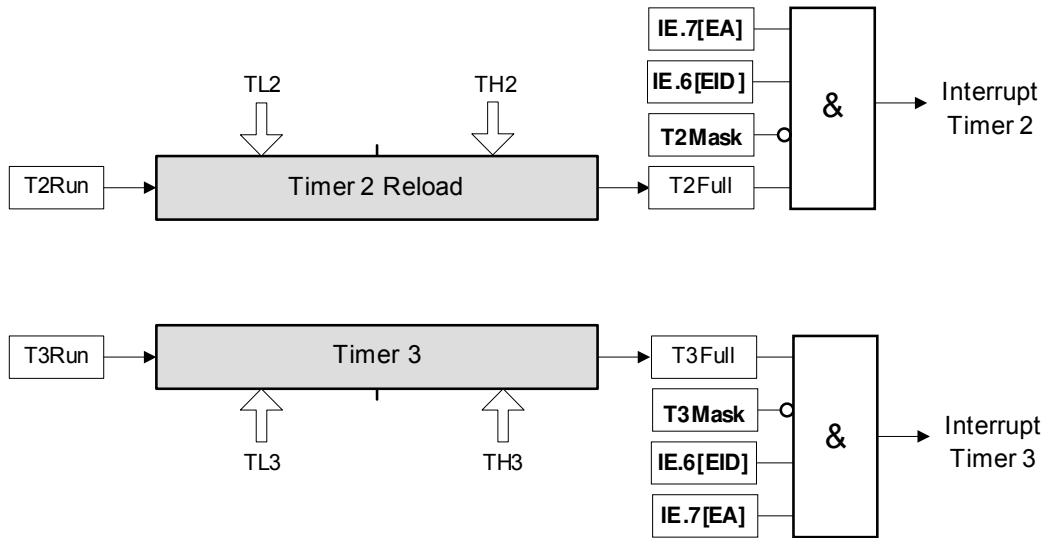

Figure 55 Timer 2/3 - Mode 6

2.14.2.2.8 Timer 2/3 - Mode 7

Comprises:

- 16-bit timer for Interval Timer calibration
- 8-bit timer with reload and bit rate strobe signal for RF Transmitter

Timer 2 operates as a 16-bit clock counter during one 2 kHz RC LP oscillator period with the counting value provided in SFR TL2 and SFR TH2, a timer run bit SFR Bit TCON2.0[T2Run], and timer overflow indicator SFR Bit TCON2.1[T2Full]. When SFR Bit TCON2.0[T2Run] is set, the counter starts counting on the next rising edge of the 2 kHz RC LP oscillator, and is stopped at the subsequent rising edge. This timer mode is used for Interval Timer Calibration by the Library functions, for example (see [1]).

Timer 3 sets up a reloadable 8-bit timer holding the startup value in SFR TL3, timer reload value in SFR TH3, timer run bit in SFR bit TCON2.4[T3Run], and timer elapsed indicator in SFR Bit TCON2.5[T3Full].

Note: This timer mode is not recommended for application usage. It is used by the Library functions for calibration.

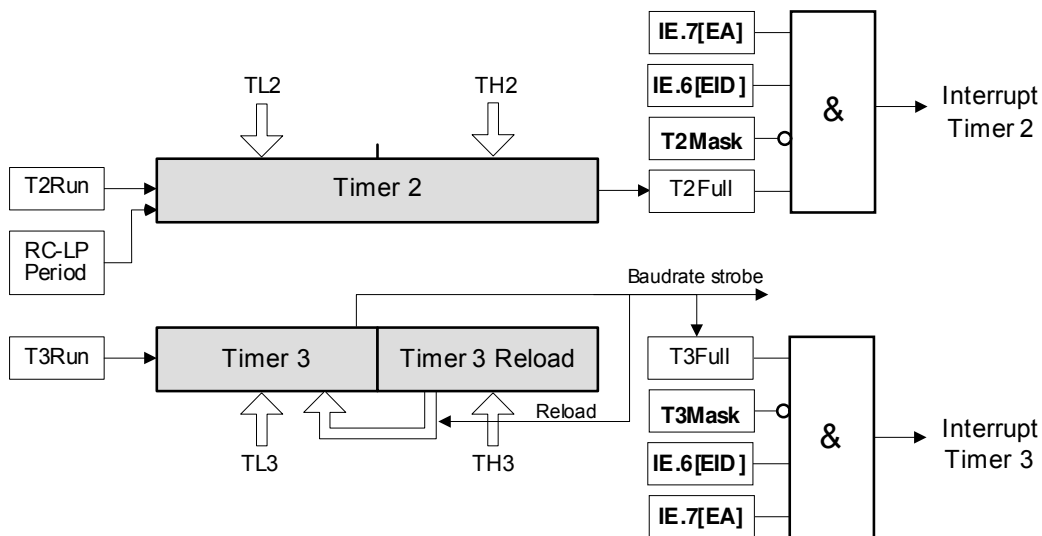

Figure 56 Timer 2/3 - Mode 7

2.14.2.3 Register Description

Table 22 Registers Overview

Register Short Name	Register Long Name	Offset Address	Wakeup Value	Page Number
TCON2	Timer Control Register Timer 2/3	C8 _H	00 _H	143
TMOD2	Timer Mode Register 2 Timer 2/3	C9 _H	00 _H	146
TL3	Timer 3 Register low byte	CA _H	00 _H	145
TH3	Timer 3 Register high byte	CB _H	00 _H	144
TL2	Timer 2 Register low byte	CC _H	00 _H	145
TH2	Timer 2 Register high byte	CD _H	00 _H	144

Timer 2 Register high byte

TH2	Offset	Wakeup Value	Reset Value
Timer 2 Register high byte	CD _H	00 _H	00 _H

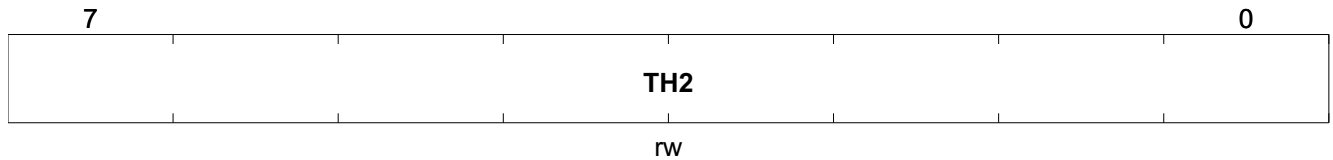

Field	Bits	Type	Description
TH2	7:0	rw	Timer 2 Register high byte

Timer 3 Register high byte

TH3	Offset	Wakeup Value	Reset Value
Timer 3 Register high byte	CB _H	00 _H	00 _H

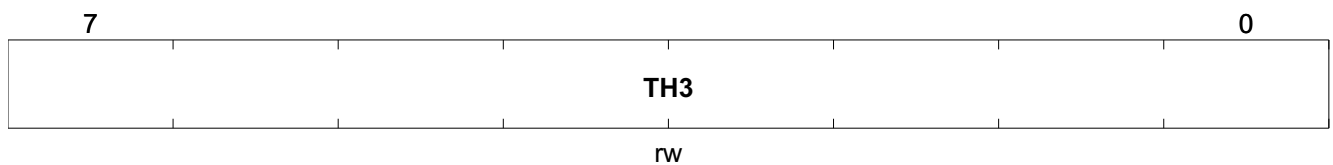

Field	Bits	Type	Description
TH3	7:0	rw	Timer 3 Register high byte

Timer 2 Register low byte

TL2	Offset	Wakeup Value	Reset Value
Timer 2 Register low byte	CC _H	00 _H	00 _H

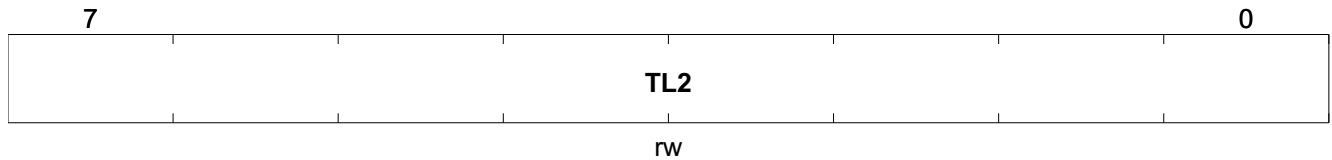

Field	Bits	Type	Description
TL2	7:0	rw	Timer 2 Register low byte

Timer 3 Register low byte

TL3	Offset	Wakeup Value	Reset Value
Timer 3 Register low byte	CA _H	00 _H	00 _H

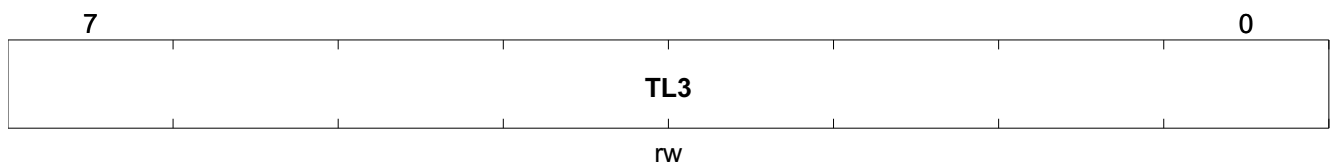

Field	Bits	Type	Description
TL3	7:0	rw	Timer 3 Register low byte

Timer Mode Register 2 Timer 2/3

TMOD2 Offset Wakeup Value Reset Value
Timer Mode Register 2 Timer 2/3 C9_H 00_H 00_H

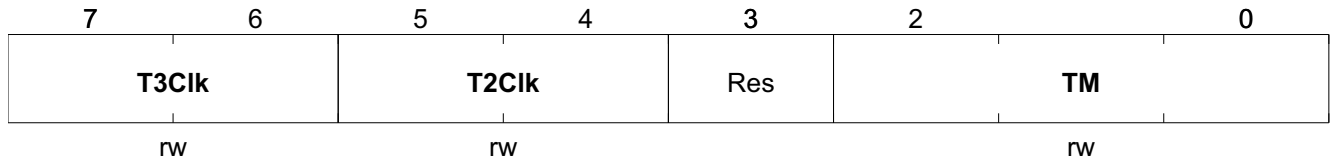

Field	Bits	Type	Description
T3Clk	7:6	rw	Timer 3 Clock Source Select (see Figure 9 “PMA5110 Clock Concept” on Page 52) 00 _B undivided system clock 01 _B system clock divided by 6 10 _B 2 kHz LP RC oscillator clock 11 _B PP2 event count (rising edge)
T2Clk	5:4	rw	Timer 2 Clock Source Select (see Figure 9 “PMA5110 Clock Concept” on Page 52) 00 _B undivided system clock 01 _B system clock divided by 6 10 _B 2 kHz LP RC oscillator clock 11 _B Timer 3 overflow event count
Res	3		Reserved
TM	2:0	rw	Timer Mode 000 _B Mode 0 001 _B Mode 1 010 _B Mode 2 011 _B Mode 3 100 _B Mode 4 101 _B Mode 5 110 _B Mode 6 111 _B Mode 7

2.15 General Purpose Input/Output (GPIO)

Ten GPIO pins are available and can either be used by the application for general purposes, or are assigned to a peripheral (**Alternative Port Functionality**). When used as GPIO pins, they can be accessed directly by the processor. Pull-up and pull-down resistors are configurable on demand to allow wired-AND and wired-OR functions. All peripheral port pins are configured as input with the pull-up resistor, which is enabled after a Power On Reset. Pin status will be kept during POWER DOWN state.

2.15.1 GPIO Port Configuration

The following table shows the different possible configurations for the GPIO Port.

Table 23 GPIO Port Configuration

PPDx	PPOx	PPSx	I/O	Pull-up/ Pull-down	Comment
0	0	-	Output	No	LOW (sink)
0	1	-	Output	No	HIGH (source)
1	0	-	Input	No	High-Z (Tri-State Bidirectional)
1	1	0	Input	Pull-up	Weak-High (Quasi Bidirectional)
1	1	1	Input	Pull-down	Weak-Low (Quasi Bidirectional)

*Note: In addition, SFR Bit PPSx defines the wake-up sensitivity for the external wake-up source (see **External Wake-up on PP1-PP4 and PP6-PP9**).*

The x in the table above has to be replaced by 0 to 9 (PP0 - PP9).

2.15.2 Spike Suppression on Input Pins

To avoid metastability when reading the GPIO pins, a synchronization stage is included and a two-stage spike filter suppresses spikes; thus data is available to be read after a delay no greater than 2 system clock periods.

Due to the synchronization stage, the following might occur:

- Signal duration (T_{SIGNAL}) < 1 system clock period ($1 T_{\text{CLK}}$): Signal is suppressed
- $1 T_{\text{CLK}} < T_{\text{SIGNAL}} < 2 T_{\text{CLK}}$: Undefined if suppressed or passed
- $T_{\text{SIGNAL}} > 2 T_{\text{CLK}}$: Signal is available in P1In or P3In register

2.15.3 External Wake-up on PP1-PP4 and PP6-PP9

PP1-PP4 and PP6-PP9 can additionally be used as external wake-up sources. To enable the external wake-ups the appropriate bit in the SFR ExtWUM must be set to 0_B and the pin must be configured as input by setting the appropriate bits in P1DIR respectively P3DIR to 1_B .

The internal pull-up/pull-down resistor is enabled if the appropriate bits in SFR P1OUT respectively in SFR P3OUT are set. SFR P1SENS respectively SFR P3SENS selects the sensitivity (active high/active low). For the settings where the internal pull-up resistor is enabled, a LOW on the appropriate PPx causes a wake-up. When the pull-down resistor is enabled with the appropriate setting a HIGH on PPx causes a wake-up. A logical description of the external wake-ups and the internal pull-up/pull-down resistors is show in **Figure 57 “Logical description of external wake-ups and internal pull-up/pull-down resistors” on Page 148**.

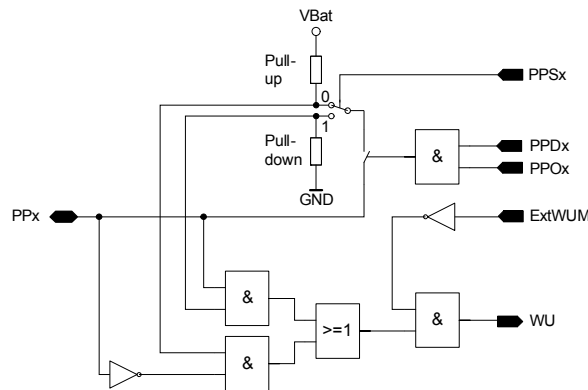

Figure 57 Logical description of external wake-ups and internal pull-up/pull-down resistors

2.15.4 Alternative Port Functionality

In the following table, the alternative port functionality is shown - which has higher priority than standard I/O port functionality.

Table 24 I/O Port 1 - Alternative Functionality

Pin	Function	I/O	Description
PP0	I2C-SCL	I	I2C Serial Clock Line Configured to I2C clock pin if SFR Bit CFG1.6 [I2CEn] is set. Weak-High has to be provided either by the internal pull-up resistor, by an external pull-up resistor or by the I2C master device.
	Port Pin I/O	I/O	Standard I/O port functionality controlled by P1Dir.0, P1Out.0, P1In.0.
	T0Gate	I/O	Can be used (alternative to the TMOD.3 [T0Gate]) as enable function for Timer 0
	OPMode1	I/O	Select operation mode (NORMAL-, DEBUG-, PROGRAMMING MODE)
PP1	I2C-SDA	I/O	I2C Serial Data Configured to I2C data pin if bit CFG1.6 [I2CEn] is set. Weak-High has to be provided either by the internal pull-up resistor, by an external pull-up resistor, or by the I2C master device.
	Port Pin I/O	I/O	Standard I/O port functionality controlled by P1Dir.1, P1Out.1, P1In.1, P1Sens.1.
	WU0	I/O	Wake-up by external wake-up source. Wake-up functionality in POWER DOWN state when enabled by setting ExtWUM.0 to zero. Wake-up level sensitivity dependent on P1Sens.1 (if set to 0, sensitive on low-level).
	T0Count	I/O	Can be used (alternative to CPU clock, TMOD.2[T0C/T]) as source for Timer 0 in counter mode.
	OPMode2	I/O	Select operation mode (NORMAL-, DEBUG-, PROGRAMMING MODE)
PP2	TxDataOut	I/O	RF Encoder data output: If bit CFG1.4[RFTXPEN] is set to one, the Manchester/BiPhase encoded data is delivered serially to PP2.
	Port Pin I/O	I/O	Standard I/O port functionality controlled by P1Dir.2, P1Out.2, P1In.2, P1Sens.2.
	WU1	I/O	Wake-up by external wake up source. Wake-up functionality in POWER DOWN state when enabled by setting ExtWUM.1 to zero. Wake-up level sensitivity dependent on P1Sens.2 (if set to 0, sensitive on low-level).
	T3Count	I/O	Can be used as clock source for Timer 3 when selected via TMOD2.7 - 6 [T3Clk.x].

Table 24 I/O Port 1 - Alternative Functionality (cont'd)

Pin	Function	I/O	Description
PP3	SPI_CS	I/O	SPI bus interface chip select
	Port Pin I/O	I/O	Standard I/O port functionality controlled by P1Dir.3, P1Out.3, P1In.3, P1Sens.3
	WU2	I/O	Wake-up by external wake-up source. Wake-up functionality in POWER DOWN state when enabled by setting ExtWUM.2 to zero. Wake-up level sensitivity dependent on P1Sens.3 (if set to 0, sensitive on low-level).
PP4	SPI_MISO	I/O	SPI bus interface master in slave out
	Port Pin I/O	I/O	Standard I/O port functionality controlled by P1Dir.4, P1Out.4, P1In.4, P1Sens.4
	WU3	I/O	Wake-up by external wake-up source. Wake-up functionality in POWER DOWN state when enabled by setting ExtWUM.3 to zero. Wake-up level sensitivity dependent on P1Sens.4 (if set to 0 sensitive on low-level).
PP5	SPI_MOSI	I/O	SPI bus interface master out slave in
	Port Pin I/O	I/O	Standard I/O port functionality controlled by P1Dir.5, P1Out.5, P1In.5, P1Sens.5
PP6	SPI_Clk	I/O	SPI bus interface clock
	Port Pin I/O	I/O	Standard I/O port functionality controlled by P1Dir.6, P1Out.6, P1In.6, P1Sens.6
	WU4	I/O	Wake-up by external wake-up source. Wake-up functionality in POWER DOWN state when enabled by setting ExtWUM.4 to zero. Wake-up level sensitivity dependent on P1Sens.6 (if set to 0, sensitive on low-level).
PP7	Port Pin I/O	I/O	Standard I/O port functionality controlled by P1Dir.7, P1Out.7, P1In.7, P1Sens.7
	ExtInt1	I/O	When enabled by setting IE.2 [EX1], this pin can generate an interrupt event that is sensitive to pin level or falling edge. The separation by level or edge is done via TCON.2 [IT1]. The interrupt flag is TCON3.[IE1].
	WU5	I/O	Wake-up by external wake-up source. Wake-up functionality in POWER DOWN state when enabled by setting ExtWUM.5 to zero. Wake-up level sensitivity dependent on P1Sens.7 (if set to 0, sensitive on low-level).
PP8	Port Pin I/O	I/O	Standard I/O port functionality controlled by P3Dir.0, P3Out.0, P3In.0, P3Sens.0
	WU6	I/O	Wake-up by external wake-up source. Wake-up functionality in POWER DOWN state when enabled by setting ExtWUM.6 to zero. Wake-up level sensitivity dependent on P3Sens.0 (if set to 0, sensitive on low-level).
	T1Gate	I/O	Can be used (alternative to the TMOD.7 [T1Gate]) as enable function for Timer 1
PP9	Port Pin I/O	I/O	Standard I/O port functionality controlled by P3Dir.1, P3Out.1, P3In.1, P3Sens.1
	Ext_Int0	I/O	When enabled by setting IE.0 [EX0] this pin can generate an interrupt event sensitive on pin level or falling edge. The separation by level or edge is done via TCON.0 [IT0]. The interrupt flag is TCON1.[IE0].
	WU7	I/O	Wake-up by external wake up source. Wake-up functionality in POWER DOWN state when enabled by setting ExtWUM.7 to zero. Wake-up level sensitivity dependent on P3Sens.1 (if set to 0, sensitive on low-level).
	T1Count	I/O	Can be used (alternative to CPU clock, TMOD.6[T1C/T]) as source for Timer 1 in counter mode.

2.15.5 Register Description

Table 25 Registers Overview

Register Short Name	Register Long Name	Offset Address	Wakeup Value	Page Number
P1Out	IO-Port 1 Data OUT Register	90 _H	UUUUUUUU _B	153
P1Dir	IO-Port 1 Direction Register	91 _H	UUUUUUUU _B	150
P1In	IO-Port 1 Data IN Register	92 _H	XXXXXXXX _B	152
P1SENS	IO-Port 1 Sensitivity Register	93 _H	UUUUUUUU _B	154
P3Out	IO-Port 3 Data OUT Register	B0 _H	000000UU _B	153
P3Dir	IO-Port 3 Direction Register	EB _H	000000UU _B	151
P3In	IO-Port 3 Data IN Register	EC _H	000000XX _B	152
P3SENS	IO-Port 3 Sensitivity Register	ED _H	000000UU _B	155

IO-Port 1 Direction Register

P1Dir IO-Port 1 Direction Register	Offset 91 _H	Wakeup Value UUUUUUUU _B	Reset Value FF _H				
7	6	5	4	3	2	1	0
PD1_7	PD1_6	PD1_5	PD1_4	PD1_3	PD1_2	PD1_1	PD1_0
rw	rw	rw	rw	rw	rw	rw	rw

Field	Bits	Type	Description
PD1_7	7	rw	PP7 direction 0 _B output 1 _B input
PD1_6	6	rw	PP6 direction 0 _B output 1 _B input
PD1_5	5	rw	PP5 direction 0 _B output 1 _B input
PD1_4	4	rw	PP4 direction 0 _B output 1 _B input
PD1_3	3	rw	PP3 direction 0 _B output 1 _B input

Functional Description

Field	Bits	Type	Description
PD1_2	2	rw	PP2 direction 0 _B output 1 _B input
PD1_1	1	rw	PP1 direction 0 _B output 1 _B input
PD1_0	0	rw	PP0 direction 0 _B output 1 _B input

IO-Port 3 Direction Register



Field	Bits	Type	Description
Res	7:2		Reserved
PP9D	1	rw	PP9 direction 0 _B output 1 _B input
PP8D	0	rw	PP8 direction 0 _B output 1 _B input

IO-Port 1 Data In Register

P1In	Offset	Wakeup Value	Reset Value				
IO-Port 1 Data IN Register	92_H	XXXXXXXX_B	XXXXXXXX_B				
7	6	5	4	3	2	1	0
PI1_7	PI1_6	PI1_5	PI1_4	PI1_3	PI1_2	PI1_1	PI1_0
r	r	r	r	r	r	r	r

Field	Bits	Type	Description
PI1_7	7	r	PP7 Data In
PI1_6	6	r	PP6 Data In
PI1_5	5	r	PP5 Data In
PI1_4	4	r	PP4 Data In
PI1_3	3	r	PP3 Data In
PI1_2	2	r	PP2 Data In
PI1_1	1	r	PP1 Data In
PI1_0	0	r	PP0 Data In

IO-Port 3 Data In Register

P3In	Offset	Wakeup Value	Reset Value
IO-Port 3 Data IN Register	EC_H	000000XX_B	000000XX_B
7	2	1	0
Res		PI3_1	PI3_0
		r	r

Field	Bits	Type	Description
Res	7:2		Reserved
PI3_1	1	r	PP9 Data In
PI3_0	0	r	PP8 Data In

IO-Port 1 Data Out Register

P1Out				Offset	Wakeup Value	Reset Value	
IO-Port 1 Data OUT Register				90 _H	UUUUUUUU _B	FF _H	
7	6	5	4	3	2	1	0
P1_7	P1_6	P1_5	P1_4	P1_3	P1_2	P1_1	P1_0
rw	rw	rw	rw	rw	rw	rw	rw

Field	Bits	Type	Description
P1_7	7	rw	PP7 Data Out
P1_6	6	rw	PP6 Data Out
P1_5	5	rw	PP5 Data Out
P1_4	4	rw	PP4 Data Out
P1_3	3	rw	PP3 Data Out
P1_2	2	rw	PP2 Data Out
P1_1	1	rw	PP1 Data Out
P1_0	0	rw	PP0 Data Out

IO-Port 3 Data Out Register

P3Out				Offset	Wakeup Value	Reset Value	
IO-Port 3 Data OUT Register				B0 _H	00000UU _B	03 _H	
7					2	1	0
Res						P3_1	P3_0
						rw	rw

Field	Bits	Type	Description
Res	7:2		Reserved
P3_1	1	rw	PP9 Data Out
P3_0	0	rw	PP8 Data Out

IO-Port 3 Sensitivity Register

This register is used select the pull-up / pull-down functionality of the GPIOs. For proper usage of the pull-up / pull-down functionality check the settings of registers P3DIR and P3OUT and see [Table 23 “GPIO Port Configuration” on Page 147](#).

P3SENS	Offset	Wakeup Value	Reset Value
IO-Port 3 Sensitivity Register	ED_H	000000UU_B	00_H

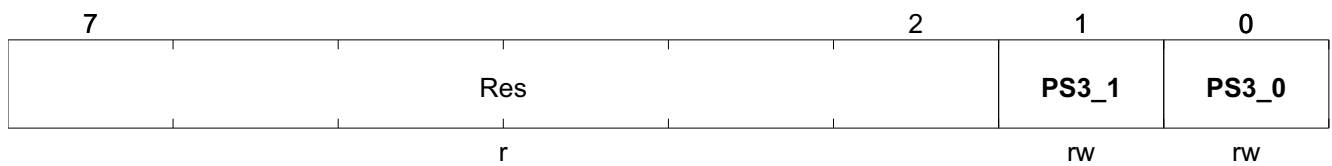

Field	Bits	Type	Description
Res	7:2	r	For future use
PS3_1	1	rw	PP9 sensitivity 0 _B Pull-up 1 _B Pull-down
PS3_0	0	rw	PP8 sensitivity 0 _B Pull-up 1 _B Pull-down

2.16 I²C Interface

For communication between external hardware (like EEPROMs, remote I/O ports, LCD drivers, RAMs...) and the PMA51xx, an I²C master/slave interface is implemented. This interface is compatible to the I²C specification.

- PP1 is used as a Serial Data line (SDA)
- PP0 is used as a Serial Clock Line (SCL)
- In Idle Mode the I²C lines are weak high
- PMA51xx responds to the I²C- Address defined in SFR I2CM (reset value is 6C_H) or to a general call if enabled by addressing slave address 00_H. General call is enabled by setting SFR bit I2CC.6[GCEn].
- The following data transfer rates according to I²C specification can be achieved
 - Slave Mode: Normal Mode (up to 100kbit/s) and Fast Mode (up to 400 kbit/s)
 - Master Mode: Normal Mode (up to 100 kbit/s)

Note: The I²C interface is used in DEBUG Mode, therefore it must not be reconfigured in DEBUG Mode. Furthermore debugging of the I²C interface itself is not possible and will lead to debugging errors.

2.16.1 Module Structure

Figure 58 points out the internal structure of the I²C-module. All activities are controlled by the Control Logic internal Control Finite State Machine (FSM). Control over the I²C bus pins is implemented in block Pin Control, responsible for start and stop bit detection and pin timing.

Besides the Control FSM the block Control Logic in addition comprises the communications timing (Timing & Delay) using the Baud rate Counter, the Bit Counter for counting incoming data bits and the Arbitration Logic for multi master operation.

The control logic internal FSM is controlled by the control register I2CC. Configuration information is given by the mode register I2CM (device address) and the baud rate register I2CB (determining the working speed of the I²C-bus). To provide information about appearing events and status information the status register I2CS is used.

The virtual register I2CD is used to store incoming and outgoing data bytes. Outgoing data bytes are moved from the internal register TX-Buffer to the Shift Register, incoming data bits are collected in the Shift Register and moved to RX-Buffer if a full byte has been received. If an address is received, this byte is compared to the device address in mode register I2CM.

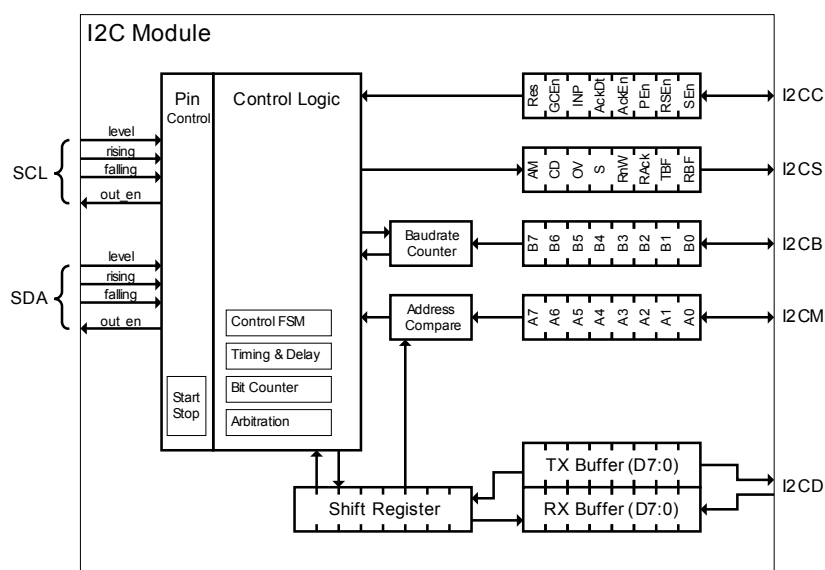

Figure 58 I²C module structure

2.16.2 I²C Programming Instructions

To enable the I²C-bus interface SFR bit CFG1.6 [I2CEn] has to be set. Further settings has to be done to prepare the I²C-module for master or slave operation.

- Configure the device by setting register I2CC. General calls can be enabled by setting bit I2CC.6[GCEn], the service request mechanism (polling/interrupt mode) has to be decided via bit I2CC.5[INP].
- Enter the device address in mode register I2CM. If no changes are done the I²C-bus matches to the predefined address 6C_H.
- The baud rate register I2CB has to be set according to the used mode and to the demands of transmission speed. In master mode the register has to be set to a maximum transfer rate proportional value.

According to the settings and according to the sequence handling mode (polling or interrupt mode) differing programming instructions have to be executed.

2.16.2.1 Slave Mode Sequence (Polling Mode)

Once the I²C-bus module has been enabled and configured to polling mode by setting bit I2CC.5[INP] to 0_B, the I²C interface waits for a start condition to occur. Subsequently the following 8 bits (7 bits address, 1 bit RnW) are shifted into an internal shift register and compared to the internal device address. When the address matches the hardware automatically generates an acknowledge and bit I2CS.7[AM] is set. Together with the address the direction bit RnW is transferred. According to its value (stored in bit I2CS.3[RnW]) different actions has to be set:

Receive I²C-data

- If bit I2CS.0[RBF] is set a data byte has been shifted in and transferred to the internal RX-Data register. The received byte is ready to be read out. An acknowledge is automatically set by hardware as long as no receive buffer overflow (bit I2CS.5[OV] in status register) has occurred.
- If bit I2CS.4[S] is set a stop condition has occurred and the transmission is closed.
- If bit I2CS.7[AM] is set a restart condition has been set on I²C-bus and a matching address has been transmitted. In case of a write access a branch to the transmit data subroutine has to be performed.

Transmit I²C-data

- In the transmit data subroutine the data to be transmitted first has to be written to register I2CD. I2CS.1[TBF] is set until the byte is transferred to the shift register and transmission is started physically - I2CS.1[TBF] is cleared again and new data can be written to I2CD. If no data byte is provided, the I²C clock line SCL is held low by the slave (the bus is blocked).
- If bit I2CS.4[S] is set, the transmission process has been terminated by the master and the transmission subroutine may be left.

2.16.2.2 Slave Mode Sequence (Interrupt Mode)

Interrupt handling is enabled by setting bit I2CC.5[INP] to 1_B. With every interrupt event the software routine restarts at the entry point of the I²C interrupt service routine, so the actual state and the cause for this interrupt has to be identified before continuing with the next step. Compared to the polling mode differing status information are needed for this non sequential handling and should be handled the following way:

- If I2CS.4[S] is set to 1_B the transfer is still active, otherwise it has been terminated.
- If I2CS.7[AM] is set, the I²C interface has been addressed as slave device (slave interrupt), otherwise a master interrupt request is pending.
- If I2CS.6[CD] is set an unexpected start or stop condition has been detected if the device has been addressed as slave device - or if acting as master device a collision has been detected on I²C bus (arbitration).
- If I2CS.3[RnW] is set, a read sequence is executed and the I²C slave device has to provide data by writing to register I2CD, otherwise a write sequence is executed and data are provided within register I2CD.

- If a write sequence is executed and I2CS.0[RBF] is set, then the received data can be read from I2CD - otherwise the address byte can be read from I2CD to decide whether to handle a general call (if enabled with I2CC.6[GCEn]) or a slave transfer.

I²C slave interrupts are generated on following events:

- If a general call has been received
- If data are received and ready to be read out from I2CD.
- If data have to be transmitted and are required in I2CD.
- If the transfer has been stopped by a stop condition or by an unexpected start or stop condition.

2.16.2.3 General Call Sequence

If a general call address is sent and bit I2CM.6[GCEn] is set the I²C bus behaves like a slave receiver, i.e. a slave mode sequence procedures may be taken. The general call protocol handling has to be done by software.

2.16.2.4 Master Mode Sequence (Polling Mode)

After enabling the I²C-bus module the I²C device behaves like a slave. If I²C bus is free of communication a master transfer can be initiated by writing an address byte (including the access direction bit RnW) to I2CD and setting a start condition with bit I2CC.0[SEn]. The start condition and the following address byte is transmitted immediately on SCL and SDA. An existing I²C device with fitting device address will then respond with an acknowledge. If the polling mode was enabled by setting bit I2CC.5[INP] to 0_B bit I2CS.3[RAck] will then be set accordingly. Consecutively the master may transmit (write data to I2CD) or receive data (read data from I2CD after reception) according to the transmitted RnW bit.

Receive I²C-data

After data reception (I2CS.0[RBF] is set) the master has to set an acknowledge. This is done by setting bit I2CC.4[AckEn] and bit I2CC.5[AckDt].

Transmit I²C-data

After writing data to register I2CD they are transmitted. If finished the master will be informed with I2CS.3[RAck] if the data have been acknowledged.

If no more data are needed to be transmitted/received the master can stop the transfer by setting a stop condition with bit I2CC.3[PEn] - or continue with a new transfer by setting a restart condition with bit I2CC.2[RSEn]. If a stop condition is issued bit I2CS.4[S] is set again. In multi master mode also pay attention to collision detection indicated by bit I2CS.6[CD].

2.16.2.5 Master Mode Sequence (Interrupt Mode)

Contrary to the master mode sequence in polling mode the I²C bus handling in interrupt mode has to be included in the slave mode interrupt sequence due to the non sequential interrupt handling. Nevertheless the master mode sequence has to be started by providing address information in I2CD and a start condition enable by setting bit I2CC.0[SEn]. Handling of the I²C transfer is then done in the interrupt service routine doing the following checks:

- If I2CS.4[S] is set to 1_B the transfer is still active, otherwise the stop condition has terminated the transfer.
- If I2CS.7[AM] is set, the I²C interface has been addressed as slave device (slave interrupt), otherwise a master interrupt request is pending.
- If I2CS.6[CD] is set a collision has been detected on I²C bus (arbitration) and an other master device took over the control.
- If I2CS.3[RnW] is set, a read sequence has been started and the I²C master device has to read the received data from register I2CD and provide acknowledge information writing I2CC.4[AckDt] and I2CC.3[AckEn].

Functional Description

- If I2CS.3[RnW] is not set, a write sequence has been started. According to the received acknowledge information provided by I2CS.2[RAck] data have to be provided by writing register I2CD or transfer has to be terminated generating a stop condition with I2CC.2[PEn] or a restart condition with I2CC.1[RSEn].

I²C master interrupts are generated on following events:

- If the I²C device has been addressed a slave interrupt is received (master acting as slave).
- If a bus collision has occurred.
- If data (or slave address) has been transmitted. Received acknowledge information can be read and further steps can be decided writing to I2CC. New data to transmit can be provided by writing to I2CD.
- If data have been received. Acknowledge information should be provided by the master interface and further steps can be decided by writing to I2CC. Data can be read from register I2CD.

2.16.3 Register Description

Table 26 Registers Overview

Register Short Name	Register Long Name	Offset Address	Wakeup Value	Page Number
I2CD	I2C Data Register	9A _H	00 _H	162
I2CS	I2C Status Register	9B _H	00 _H	163
I2CC	I2C Control Register	A2 _H	00 _H	161
I2CM	I2C Mode Register	A3 _H	6C _H	162
I2CB	I2C Baud rate Register	B1 _H	00 _H	160

I²C Baud rate Register

This register is used to control the I²C-bus transmission speed in master mode. In slave mode this register is used to determine the data setup time after SCL hold (delay by slave). The value can be calculated by the equation shown in [Figure 59](#).

$$I2CB = SCL_{high}[s] \cdot \left(\frac{f_{sys}[Hz]}{2}\right) - 1$$

Figure 59 Calculation of I²C baud rate

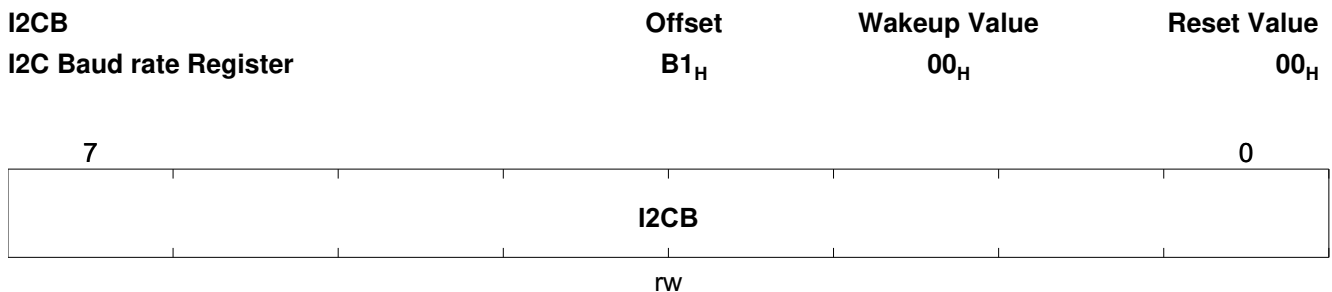

Field	Bits	Type	Description
I2CB	7:0	rw	I2C Baud rate Register Data transfer rate compliant value for SCL hold time (master behavior) or data setup time after SCL hold (slave behavior).

Functional Description

Field	Bits	Type	Description
SEn	0	rw	Start condition enable Initiates a start condition on the correct position in the transmission frame in master mode. This bit is automatically reset by hardware afterwards. 0 _B Idle 1 _B Set start condition

I²C Data Register

RX-Buffer and TX-Buffer are two data transmission registers that are accessible by the virtual register I2CD. If read, the content of the RX-Buffer is provided, if written the TX-Buffer is filled.

I2CD	Offset	Wakeup Value	Reset Value
I2C Data Register	9A _H	00 _H	00 _H

7	I2CD				0
rw					

Field	Bits	Type	Description
I2CD	7:0	rw	I2C Data Register Provide access to TX-Buffer if written and RX-Buffer if read.

I²C Mode Register

This register is used to set the I²C address of the PMA51xx.

I2CM	Offset	Wakeup Value	Reset Value
I2C Mode Register	A3 _H	6C _H	6C _H

7	A7_1		1	0
rw				Res
rw				r

Field	Bits	Type	Description
A7_1	7:1	rw	I2C Address bit 7 down to bit_1
Res	0	r	I2C Address Bit 0 This bit is fixed to 0 _B

I²C Status Register

I2CS	Offset							Wakeup Value	Reset Value
I2C Status Register	9B _H							00 _H	00 _H
	7	6	5	4	3	2	1	0	
	AM	CD	OV	S	RnW	RAck	TBF	RBF	
	rc	rc	rc	rc	r	r	r	r	

Field	Bits	Type	Description
AM	7	rc	<p>Address matched / Slave transfer Polling mode (I2CC.5[INP] is set to 0_B): Set if received device address matches with received address byte (corresponding to 7-bit or 10-bit addressing mode). Interrupt mode (I2CC.5[INP] is set to 1_B): Set while PMA51xx has been addressed as slave device. This bit is automatically reset by hardware when the transfer is stopped.</p> <p>0_B Idle 1_B Address matched (polling) / Slave transfer (interrupt)</p>
CD	6	rc	<p>Collision detected If master transfer is executed, this bit is set if a collision was detected. If a slave transfer is executed, this bit is set if an unexpected start/stop condition occurs during address/data transfer.</p> <p>0_B Idle 1_B Collision detected</p>
OV	5	rc	<p>Overflow Set if new data have been received and old data in the RX-Buffer (I2CD register) were not read. Set if data are still pending in the TX-Buffer when new data are written into I2CD.</p> <p>0_B Idle 1_B Buffer overflow detected</p>
S	4	rc	<p>Stop bit detected / Transfer active Polling mode (I2CC.5[INP] is set to 0_B): Set if stop condition has been detected. Interrupt mode (I2CC.5[INP] is set to 1_B): Set as long as an ongoing transfer is detected.</p> <p>0_B Idle 1_B Stop bit detected (polling) / ongoing transfer (interrupt)</p>
RnW	3	r	<p>Read / not write bit information Contains the type of transfer. If master transfer is executed this bit is automatically captured on sending the address. If a slave transfer is executed this bit is captured on receiving the address.</p> <p>0_B Write transfer (slave-receiver / master-transmitter) 1_B Read transfer (slave-transmitter / master-receiver)</p>

Functional Description

Field	Bits	Type	Description
RAck	2	r	<p>Received acknowledge level Contains the level of the received acknowledge.</p> <p>0_B Received NOT acknowledge (nACK) 1_B Received acknowledge (ACK)</p>
TBF	1	r	<p>Transmit buffer full Set if register I2CD is written. Cleared by hardware if the TX-Buffer is moved to the shift register, thus the data byte is transmitted.</p> <p>0_B Transmit buffer empty 1_B Transmit buffer full</p>
RBF	0	r	<p>Receive buffer full Set if the content from the shift register is moved to the RX-Buffer, thus data byte is received. Cleared by hardware if register I2CD is read.</p> <p>0_B Receive buffer empty 1_B Receive buffer full</p>

2.17 SPI Interface

The Serial Peripheral Interface (SPI) is a very simple synchronous interface to transfer data on a serial bus, connecting an intelligent master controller with general-purpose slave circuits such as slave controller, RAMs, memories, and so on. A simple 2-wire (half-duplex mode) or 3-wire (full-duplex mode) bus is used for communication.

- High-speed synchronous data transfer
- Four programmable bit rates through prescaler
- 2-wire bus for half-duplex transmission; a serial clock line (SPI_Clk) and concatenated data line (SPI_MISO, SPI_MOSI)
- 3-wire bus for full-duplex transmission; a serial clock line (SPI_Clk) and two serial data lines (SPI_MISO, SPI_MOSI)
- A 4-wire bus for full-duplex transmission plus handshaking can be implemented by also utilizing the Chip Select (SPI_CS). This pin can be used for indicating the beginning of a new byte sequence.
- Master or Slave Operation
- Clock Control - Polarity (idle low/high) and phase (sample data with rising/falling clock edge) are programmable
- Bit Width (1 to 8 bits) and Bit Order (MSB or LSB first) are configurable
- Compatible with SSC (High-Speed Synchronous Serial Interface) and standard SPI interfaces
- Protocol is defined by software

2.17.1 SPI Functionality

The basic interaction principle between master and slave SPI devices is shown in [Figure 60](#). Writing to the SPI shift register of the master SPI device starts the SPI clock generation (line SCK). The two 8 bit shift registers in master and slave device can be considered as one distributed circular shift register (including line MISO and MOSI). When data is shifted from the master to the slave with the generated clock, data is also shifted in the opposite direction simultaneously. During one shift cycle, data in the master and the slave is interchanged resulting a full duplex transmission.

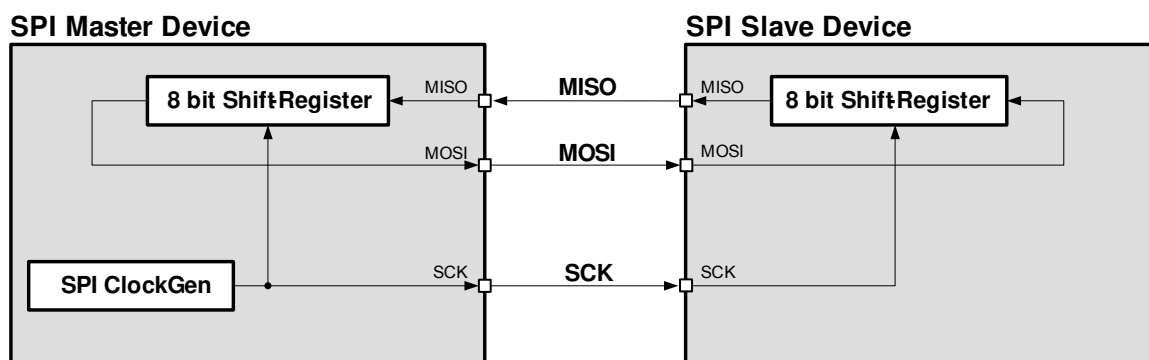

Figure 60 SPI principle

Different SPI devices are connected through three lines. The definition of these lines is always determined by the master. The line connected to the master's data output is the transmit line MOSI¹⁾, the receive line is connected to its data input line MISO²⁾. The serial clock is distributed over line SCK³⁾. Only the device selected for master operation generates and outputs the serial clock. All slaves receive and react to this clock.

1) MOSI = Master Out Slave In
 2) MISO = Master In Slave Out
 3) SCK = Serial clock

The output of the master's shift register is connected to the external transmit line, which in turn is connected to the slaves' shift register input (MOSI). The output of the slaves' shift register is connected to the external receive line in order to enable the master to receive the data shifted out of one slave (MISO). The external connections are hard-wired, the function and direction of the pins are determined by configuration as master- or slave device.

When initializing the devices select only one device for master operation, all others must be programmed for slave operation. Initialization includes the operating mode (clock phase, clock polarity, data byte order, bit width and transfer rate). To deselect the actual master (slave-select functionality) and re-establish connection with another master, a corresponding protocol has to be fulfilled by software using an additional free port pin.

To avoid collisions on line MISO due to several slave devices, only one slave is allowed to pull the line to low (wired AND connection), i.e. enables the driver of its pin. Only this slave can put its data onto the master's receive line and only receiving of data from the master is possible. The master selects the slave device from which it expects data either by separate select lines (free port lines), or by using a suitable protocol to tell all the other slave devices to only output state high on line MISO.

According to the hard-wired connection, two different operation modes are possible - Full-Duplex and Half-Duplex operation.

2.17.1.1 Full-Duplex Operation

The master device line MOSI (master out) is connected to line MOSI of all slave devices (slave in). Accordingly line MISO is connected between master and slave devices. Additionally to this two data lines the clock line SCK has to be wired respectively. This way data are transmitted across a 3-wire bus in full duplex mode (refer to [Figure 61](#)). Data bytes are transmitted from master to slave and simultaneously from slave to master.

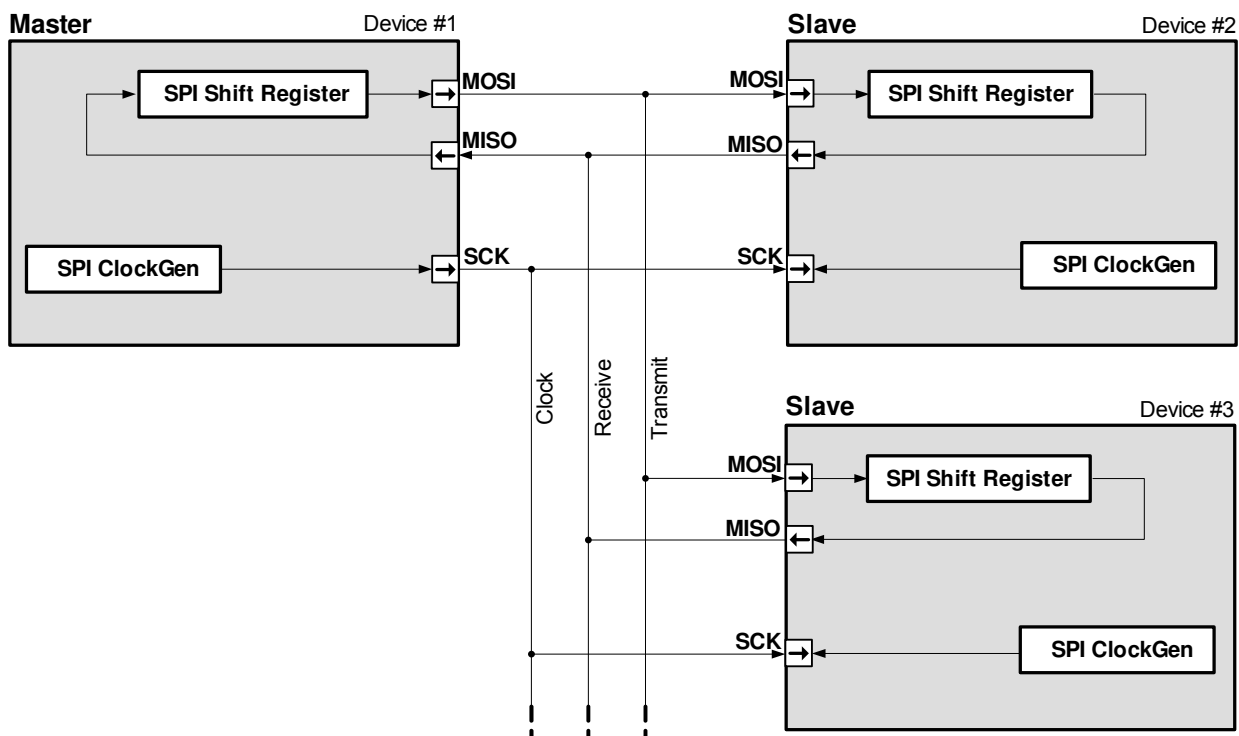

Figure 61 Full-Duplex configuration

2.17.1.2 Half-Duplex Operation

In a Half-Duplex configuration only one data line is necessary for both receiving and transmitting data. **Figure 62** shows, that line MISO and MOSI of each master and slave device is shortened to one data line. The clock line SCK is connected exclusively. The master device controls the data transfer by generating the shift clock, while the slave device receives it.

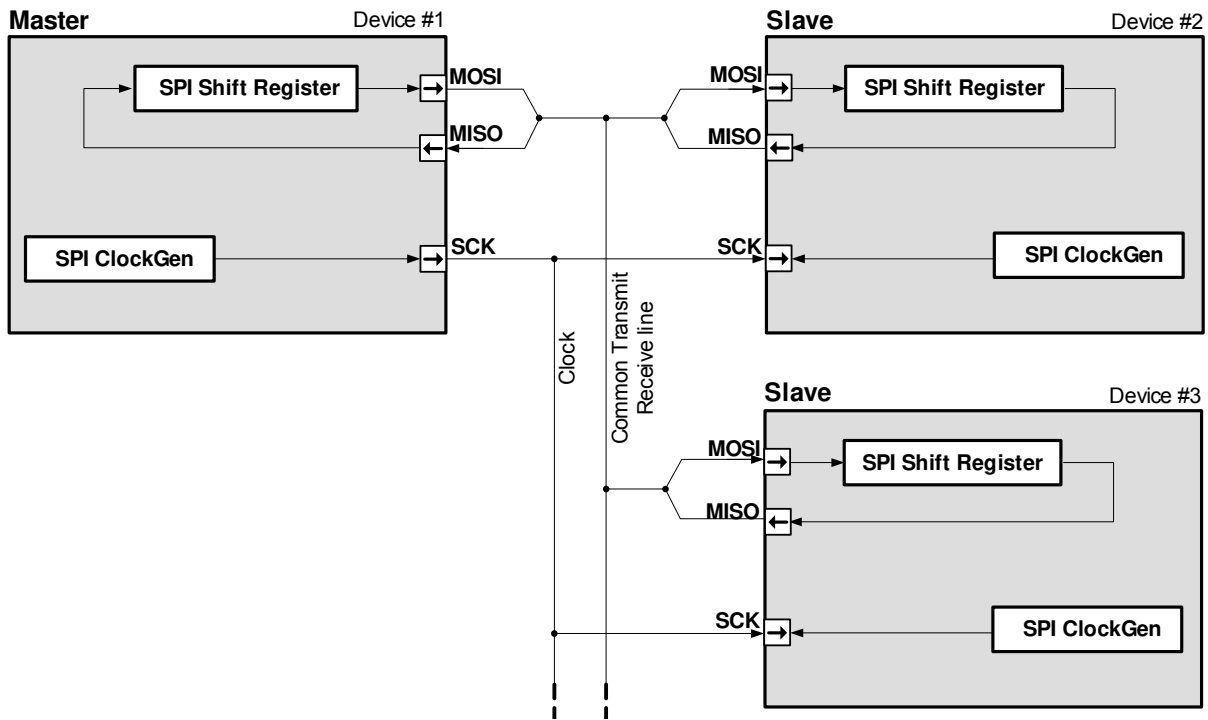

Figure 62 Half-Duplex Configuration

Due to the fact that all transmit and receive pins are connected to one data line, an appropriate protocol has to be used to avoid collisions, i.e. only one device (master or slave) may transmit data unidirectional, all other (arbitrary) devices are only allowed to receive these data (therefore the shift register has to contain FF_H). Because line MISO and MOSI of each device is shortened, the transmitting device will clock its own data at the input pin. By these means any corruptions on the common data exchange line are detected.

2.17.1.3 Data Modes

There are four combinations of SCK phase and polarity with respect to serial data, which is determined by control bits SPIC.2[CPHA] and SPIC.3[CPOL] (refer to [Figure 63](#)). Additionally the data order (bit SPIC.5[DORD]) (MSB-first or LSB-first) and the data width (bit SPIM.2:0[DWS]) (variable from 1 to 8 bits) may be changed.

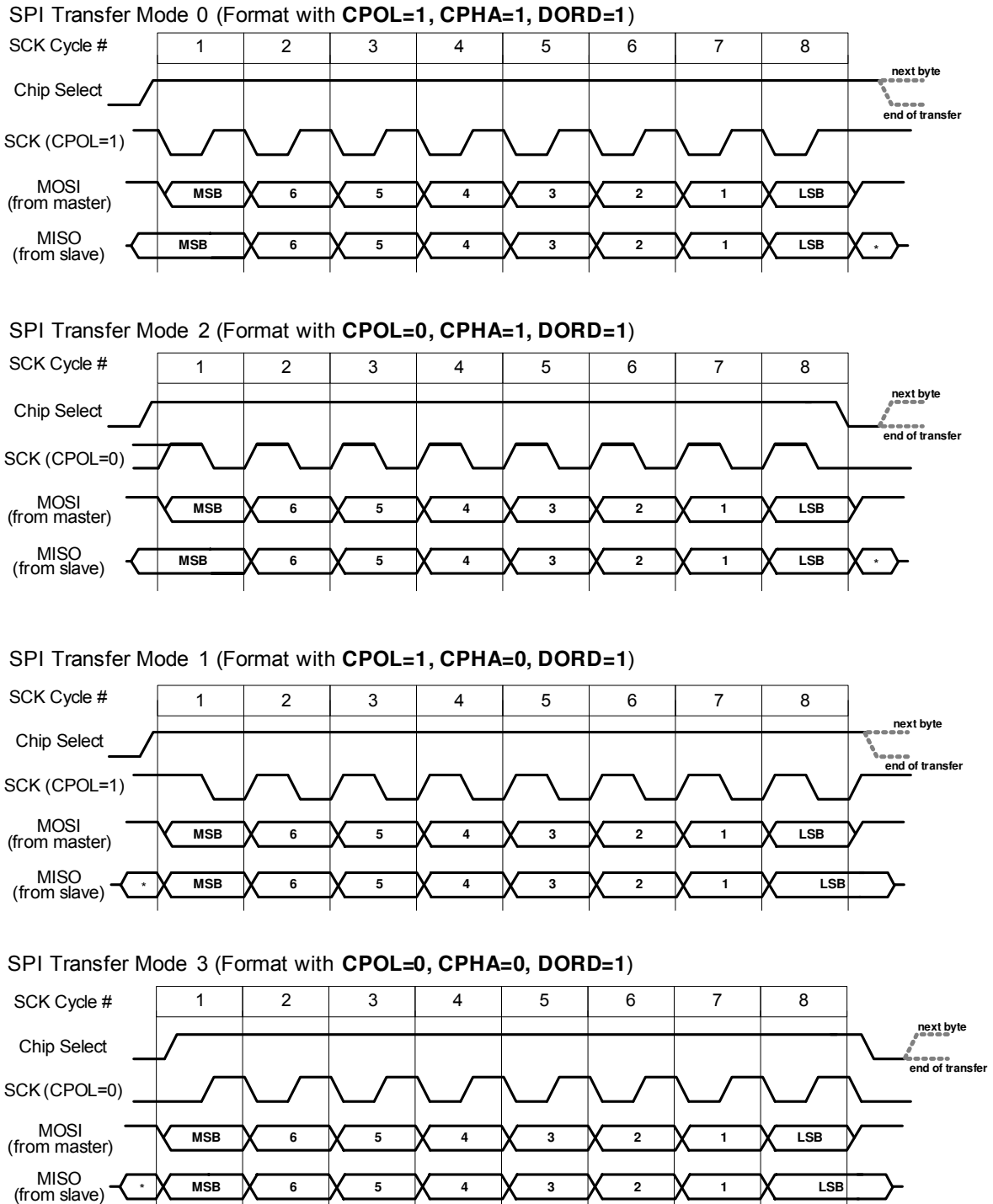

Figure 63 SPI data modes

2.17.2 Module Structure

Figure 64 points out the main blocks inside the SPI module. The Pin Control block separates and assigns incoming and outgoing SPI signals. According to this signals and the configurations done in SPI control register (SPIC) and SPI mode register (SPIM) the SPI Control block coordinates Shift Register shift-in and shift-out.

The Clock Control block is only relevant in SPI master mode: the SPI clock is generated by the internal baud rate timer. The baud rate timer is a 8 bit down counter, its overrun toggles the SPI clock.

Transmit Buffer and Receive Buffer are used to store incoming and outgoing data bytes. Outgoing data bytes are first transferred from Transmit Buffer to the Shift Register that dispenses bit by bit in compliance to the data order (MSB or LSB first) set by bit SPIC.5[DORD]. At start of a frame 2 bytes can be written into the TX buffer. First is moved through TX buffer into Shift register. Second byte is hold in TX buffer until first byte was sent.

Incoming data bits are collected in the Shift Register. If all bits are received - the exact amount is defined by SPIM.2-0[DWS2-0] - the whole byte is moved to Receive Buffer.

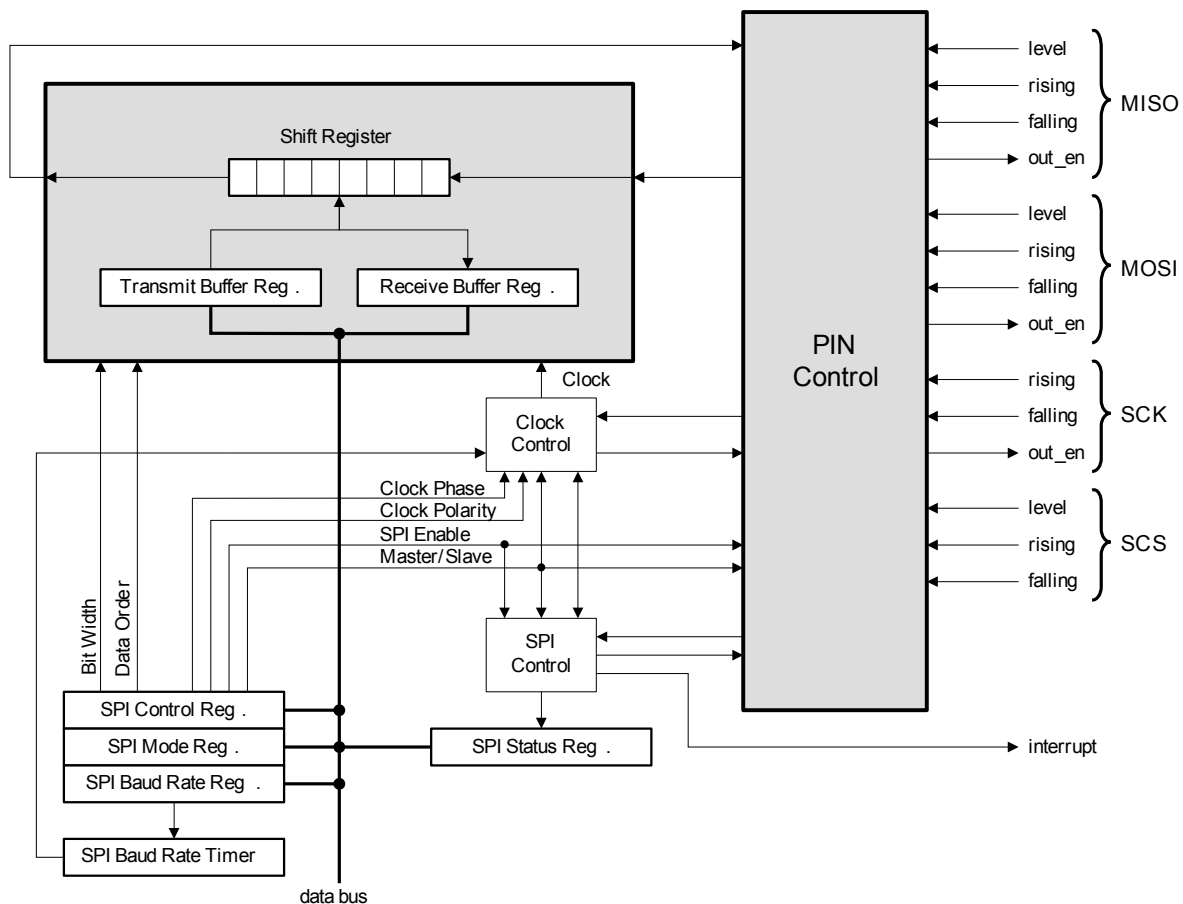

Figure 64 SPI module structure

2.17.3 Interrupt Support

Six events generates an interrupt. First three sources are normal operating interrupts, last three are failures:

- Receive Buffer Full (SPIS.1[SRBF]) and Reload TX buffer as one single event because of SPI behavioral.
- Chip select (SPI_CS) detected (SPIS.3[SCSD]) (Slave Mode only).
- Chip select (SPI_CS) lost and the last word was transferred completely (Slave Mode only).
- Receive Buffer Overrun (SPIS.7[SRE]) (data lost) detected.
- Phase Error detected (SPIS.5[SPE]).

- Slave Communication Corrupt detected (SPIS.4[SSCC]). In this case the Slave Select was lost within a word (Slave Mode only).

All these interrupt source bits are located in the status register (SPIS) and will be cleared on read access. A read access to status register acknowledges the interrupt.

It is not possible to mask one or more of these interrupt sources individually, only all SPI interrupts can be masked by setting SFR bit IE.5 [ESPI] to 0_B.

2.17.4 SPI Programming Instructions

To enable the SPI-bus interface bit CFG1.2[SPIEn] has to be set. Resume with setting correct configuration in control and mode register (SPIC and SPIM).

2.17.4.1 Slave Mode Sequence

Once the SPI interface has been enabled, configured as slave, and selected via chip select (SPI_CS/PP3), it waits for incoming data, which are shifted-in synchronously to the delivered SPI clock. There are two possibilities to select the slave:

1. The SPI slave is selected by the master via an hard-wired signal connected to SPI_CS/PP3.
2. The SPI slave sets the chip select to 0_B by setting PP3 direction to output and PP3 to 0_B.

After all bits has been transmitted, bit SPIS.1[SRBF] is set and the data can be read out from register SPID. If data should be (according to the realized protocol) transmitted simultaneously to the next incoming data byte, simply write the desired byte to the SPI data register SPID.

2.17.4.2 Master Mode Sequence

After enabling the SPI interface and configuration as master device it waits for further actions. Data are transmitted/received as soon as the SPI data register SPID is written. If more than one data byte has to be transmitted keep in mind to check bit SPIS.0[STBF] to not overwrite the old data byte. In full duplex mode data bytes are simultaneously received from slave devices. If a byte has to be read according to the implemented protocol simply check bit SPIS.1 [SRBF] in status register and read out the received value from register SPID.

2.17.5 Register Description

Table 27 Registers Overview

Register Short Name	Register Long Name	Offset Address	Wakeup Value	Page Number
SPIB	SPI Baud rate Register	F3 _H	00 _H	171
SPIC	SPI Control Register	F4 _H	00 _H	172
SPID	SPI Data Register	F5 _H	00 _H	173
SPIM	SPI Mode Register	F6 _H	00 _H	173
SPIS	SPI Status Register	F7 _H	41 _H	175

SPI Baud rate Register

The internal baud rate timer is needed only in master mode. It is implemented as 8-bit down counter. The Register SPIB holds counter's reload value. A underrun from 00_H to FF_H initiates both timer reload and a SPI clock event. This SPI clock event generates either a rising or falling edge on the SPI clock line. For a full SPI clock cycle two SPI clock events are necessary.

The baud rate can be calculated by the formula shown in [Figure 65](#).

$$f_{SPI}[Hz] = \left(\frac{f_{SYS}[Hz]}{(SPIB + 1) \cdot 2} \right)$$

Figure 65 Calculation of SPI baud rate

All reload values for SPIB from 00_H to FF_H are valid.

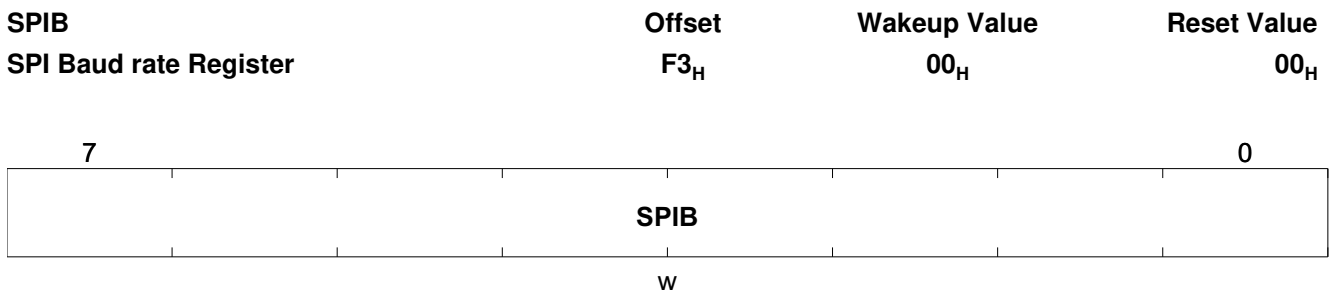

Field	Bits	Type	Description
SPIB	7:0	w	SPI Baud rate Register Reload value for baud rate timer

SPI Control Register

SPIC Offset Wakeup Value Reset Value
 SPI Control Register F4_H 00_H 00_H

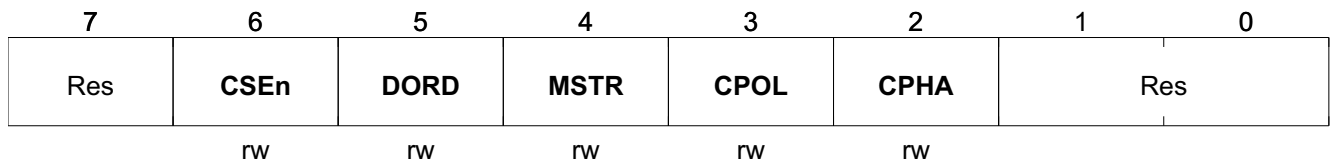

Field	Bits	Type	Description
Res	7		Reserved
CSEn	6	rw	Chip select enable (slave mode only) Resets the internal FSM if CS is lost during transmission in slave mode. 0 _B Disable SPI chip select 1 _B Enable SPI chip select
DORD	5	rw	Data order Defines the bit order for transmission. 0 _B LSB is transmitted first 1 _B MSB is transmitted first
MSTR	4	rw	Master/Slave select Defines if the module operates as master or slave device. 0 _B Slave (controls SPI_MISO) 1 _B Master (controls SPI_MOSI, SPI_Clk)
CPOL	3	rw	Clock polarity selection Defines the initial state of SPI clock line. 0 _B Idle clock line is low and leading clock edge is a low to high transition. 1 _B Idle clock line is high and leading clock edge is a high to low transition.
CPHA	2	rw	Clock phase selection Determines whether data are active with rising or falling edge of SPI clock line. 0 _B Transmission starts without a rising or falling edge on SPI clock. With first edge detected the first data bit is latched, with the following edge data are shifted. 1 _B A rising or falling edge is generated on SPI clock line before data are set. With the following clock edge data are latched before shifted on with consecutive one.
Res	1:0		Reserved

SPI Data Register

SPID	Offset	Wakeup Value	Reset Value
SPI Data Register	F5 _H	00 _H	00 _H

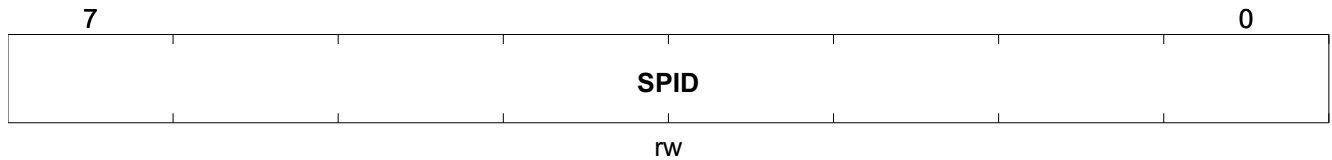

Field	Bits	Type	Description
SPID	7:0	rw	SPI Data Register Read from RX buffer and write to TX buffer

SPI Mode Register

SPIM	Offset	Wakeup Value	Reset Value
SPI Mode Register	F6 _H	00 _H	00 _H

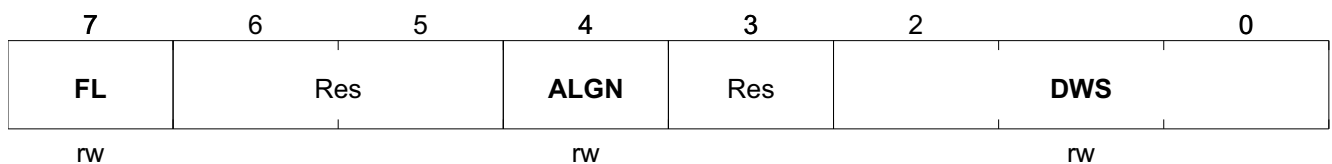

Field	Bits	Type	Description
FL	7	rw	SPI force level Select output mode for SPI lines SPI_MISO, SPI_MOSI and SPI_Clk. 0 _B SPI lines are pull-up driven weak high level 1 _B SPI lines are active driven high level
Res	6:5		Reserved
ALGN	4	rw	Data alignment Defines the bit alignment for SPI transmission. This is only relevant in case, data width selection is not 8 bits (see DWS). 0 _B Right align 1 _B Left align
Res	3		Reserved

Functional Description

Field	Bits	Type	Description
DWS	2:0	rw	Data width selection Defines the number of transmitted bits per byte. 000 _B 8 bits 001 _B 1 bit 010 _B 2 bits 011 _B 3 bits 100 _B 4 bits 101 _B 5 bits 110 _B 6 bits 111 _B 7 bits

SPI Status Register

SPIS SPI Status Register	Offset F7 _H	Wakeup Value 41 _H	Reset Value 41 _H
-----------------------------	---------------------------	---------------------------------	--------------------------------

7	6	5	4	3	2	1	0
SRE	STE	SPE	SSCC	SCSD	SCSL	SRBF	STBE
rc	r	rc	rc	rc	rc	rc	r

Field	Bits	Type	Description
SRE	7	rc	SPI receive error Is set by hardware if a new data frame is completely received but the previous data was not read out from the receive data buffer SPID (data will be overwritten). This bit acts as interrupt request flag. It is cleared by hardware on read access. 0 _B Normal state 1 _B Error occurred
STE	6	r	SPI transmission completed This bit is set if the SPI transmission has been completed. 0 _B Transmission running 1 _B Transmission completed
SPE	5	rc	SPI phase error Is set by hardware if the incoming data at pin MISO (master mode) respectively MOSI (slave mode) sampled with CPU clock, changes between 1 sample before and 2 samples after latching edge of the clock signal. This bit acts as interrupt request flag. It is cleared by hardware on read access. 0 _B Normal state 1 _B Phase error detected
SSCC	4	rc	SPI Slave communication corrupted Set by hardware if the chip select is lost during transmission (in slave mode only). This bit acts as interrupt request flag. It is cleared by hardware on read access. 0 _B Normal state 1 _B Transmission corrupted
SCSD	3	rc	SPI chip select detected Set by hardware in slave mode only if an falling edge is detected on SPI-CS pin (SPI transmission start). This bit acts as interrupt request flag. It is cleared by hardware on read access. 0 _B Inactive 1 _B Chip select detected (falling edge on chip select detected)

Functional Description

Field	Bits	Type	Description
SCSL	2	rc	<p>SPI chip select lost Set by hardware in slave mode if a rising edge is detected on SPI-CS. This bit acts as interrupt request flag. It is cleared by hardware on read access.</p> <p>0_B Inactive 1_B Chip select lost (rising edge on chip select detected)</p>
SRBF	1	rc	<p>SPI receive buffer full Is set by hardware if a data byte is received completely. The receive buffer (SPID) is ready to be read. This bit acts as interrupt request flag. It is cleared by hardware on read access.</p> <p>0_B No new data in receive buffer 1_B New data in receive buffer</p>
STBE	0	r	<p>SPI transmit buffer empty Is reset by hardware if register SPID is written and automatically set if data byte is transferred to SPI internal shift register.</p> <p>0_B There are still data in transmit buffer 1_B Transmit buffer is empty</p>

2.18 PROGRAMMING Mode Operation

In PROGRAMMING mode, the PMA51xx is accessible as a slave using the I²C Interface.

The device uses the internal 12 MHz RC HF oscillator as its clock source.

To avoid programming failures, all PROGRAMMING mode commands are protected by a 16-bit CRC at the end of each command ([Chapter 2.12](#) shows details about the CRC polynomial used).

The checksum has to be calculated over all bytes in the command excluding the PMA51xx I²C device address. [Figure 66 “Legend for I²C-Commands in PROGRAMMING mode” on Page 177](#) shows the legend used for the description of the I²C commands.

PROGRAMMING mode Commands

- FLASH Write Line
- FLASH Erase
- FLASH Check Erase Status
- FLASH Read Line
- FLASH Set Lockbyte 3
- FLASH Read Status



	from programmer to PMA	S	start condition
	from PMA to programmer	P	stop condition
CRCH	MSB of CRC checksum	SR	restart condition or stop / start condition
CRCL	LSB of CRC checksum	A	acknowledge
Data0-31	data which is written into / read from FLASH	nA	not acknowledge
Pause	Time where no communication is allowed	Sector	selection of the sector
Status	Status byte		

Figure 66 Legend for I²C-Commands in PROGRAMMING mode

2.18.1 FLASH Write Line

The FLASH Write Line command writes 32 bytes to the FLASH. The FLASH Code Sector and FLASH User Data Sectors can be written using this command. The start address has to be a multiple of 20_H. As shown in [Figure 12](#) FLASH address range 4000_H to 587F_H is accessible.

This command should only be used if the FLASH line is fully erased. If an already programmed FLASH line gets overwritten (without being erased first) the resulting data is undefined. After the stop condition (P) is received the data is programmed into the FLASH. During the programming time incoming I²C commands are not acknowledged. Programming time is specified in [Table 46](#). [Figure 67](#) shows the structure of the FLASH Write Line command. It is important to note that no type of *verification* is performed after a write. In order to see if this write command was successful, a [Read Status](#) command must be issued, or a [FLASH Read Line](#) command may be used to read back the stored values.

Note:

1. If transferring the start address, the lower 5 bits are cleared automatically.
2. If less than 36 data bytes are received, nothing is written into the FLASH. The Read Status command can be used to check an invalid command length error.
3. If an already written section in the FLASH gets re-written (without being erased before), the resulting data is undefined.

4. After the stop condition (P) is received the data is programmed into the FLASH. During the programming time incoming I²C commands are not acknowledged.

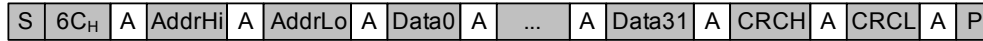

Figure 67 FLASH Write Line command

2.18.2 FLASH Read Line

The contents of the FLASH memory (4000_H to 587F_H) can be read out via the I²C interface. Figure 68 shows the structure of the FLASH read line command.

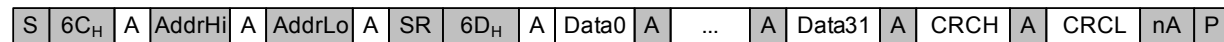

Figure 68 FLASH Read Line command

2.18.3 FLASH Erase

The FLASH Erase command is show in Figure 69 and can be used to erase the Code Sector and the User Data Sectors. The FLASH Erase time is specified in Table 46. Figure 70 and Table 28 describe the bits of the Sector byte.

Note: After the stop condition (P) is received the selected FLASH sectors are being erased. During the erase time incoming I²C commands are not acknowledged.

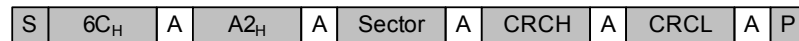

Figure 69 FLASH Erase command



Figure 70 FLASH Erase: Sector byte

Table 28 FLASH Erase: Sector byte

Bits	Field	Description
2	UDSec II	0 _B : don't erase User Data Sector II 1 _B : erase whether User Data Sector II is erased
1	UDSec I	0 _B : don't erase User Data Sector I 1 _B : erase whether User Data Sector I is erased
0	CSec	0 _B : don't erase Code Sector 1 _B : erase whether Code Sector is erased

2.18.4 FLASH Check Erase Status

This function returns the status of the selected FLASH sector(s). The time required for checking the sectors depends on the selected sectors. The structure of the I²C command *FLASH Check Erase Status* is shown in **Figure 71**. **Figure 72** and **Table 29** describe the bits of the Sector byte. The Status byte is illustrated in **Figure 73** and **Table 30**.

Note: After the first stop condition (P) is received the selected FLASH sectors are checked. During this time incoming I²C commands are not acknowledged.

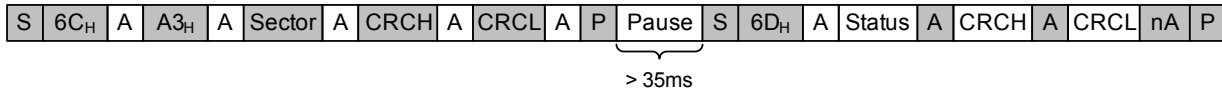

Figure 71 FLASH Check Erase Status command

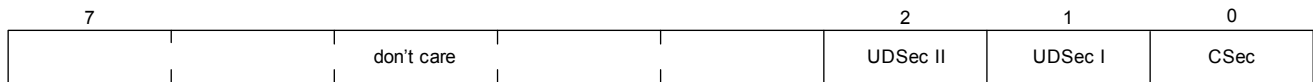

Figure 72 FLASH Check Erase Status: Sector byte

Table 29 FLASH Check Erase Status: Sector byte

Bits	Field	Description
2	UDSec II	0 _B : don't check User Data Sector II 1 _B : check whether User Data Sector II is erased
1	UDSec I	0 _B : don't check User Data Sector I 1 _B : check whether User Data Sector I is erased
0	CSec	0 _B : don't check Code Sector 1 _B : check whether Code Sector is erased

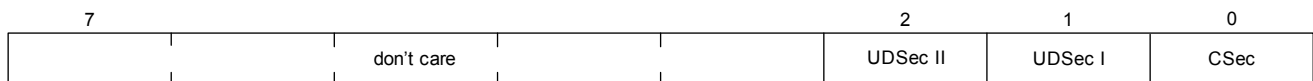

Figure 73 FLASH Check Erase Status: Status byte

Table 30 FLASH Check Erase Status: Status byte

Bits	Field	Description
2	UDSec II	0 _B : User Data Sector II is erased or untested 1 _B : at least one bit is set in User Data Sector II
1	UDSec I	0 _B : User Data Sector I is erased or untested 1 _B : at least one bit is set in User Data Sector I
0	CSec	0 _B : Code Sector is erased or untested 1 _B : at least one bit is set in Code Sector

2.18.5 FLASH Set Code Lock (Lockbyte 2)

To set Lockbyte 2 D1_H has to be written to FLASH address 577F_H (top address of Code Sector). After the Lockbyte 2 is set, a startup in DEBUG or PROGRAMMING mode is not possible any more.

Note: To activate the Code Sector Lock the PMA51xx has to be reset after Lockbyte D1_H has been set.

2.18.6 FLASH Set User Data Sector Lock (Lockbyte 3)

This command sets the Lockbyte for FLASH User Data Sectors I + II.

Note: It is required to set Code Sector Lock (Lockbyte 2) to enable User Data Sector Lock (Lockbyte 3) to become effective.

Note: To activate the User Data Sector Lock (Lockbyte 3) the PMA51xx has to be reset after setting the Lockbytes for User Data Sector and Code Sector.



Figure 74 FLASH Set Lockbyte 3 command

2.18.7 Read Status

This function is intended to read out the status of the previous executed functions (pass/fail). It can be called whenever desired to verify if there were errors since the last *Read status* call. [Figure 76](#) and [Table 31](#) describe the bits of the Status byte.

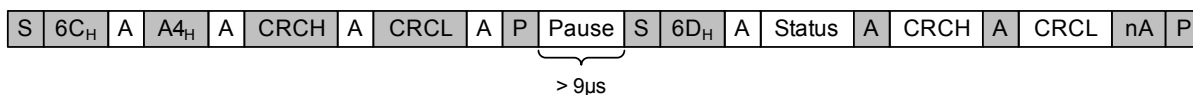

Figure 75 Read Status command

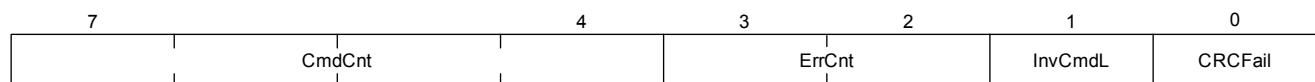

Figure 76 Read Status: Status byte

Table 31 Read Status: Status byte

Bits	Field	Description
7:4	CmdCnt	Number of executed commands since the first detected error. 1111 _B : 15 commands or more 1110 _B : 14 commands ... 0001 _B : 1 command 0000 _B : error occurred in last command
3:2	ErrCnt	Erroneous events since the last Read status call. 11 _B : three or more errors 10 _B : two errors 01 _B : one error 00 _B : no error
1	InvCmdL	1 _B : Invalid command length or execution fail since the last Read status call 0 _B : Command length and execution correct since the last Read status call
0	CRCFail	1 _B : CRC Failure detected since the last Read status call 0 _B : no CRC Error occurred since the last Read status call

2.19 DEBUG Mode Operation

Debugging of the PMA is done via the I²C interface, therefore the I²C interface must not be reconfigured in DEBUG Mode. Furthermore debugging of the I²C interface itself is not possible and will lead to debugging errors.

Note: The FLASH is protected against write access in DEBUG mode. RAM area EB_H - FF_H is used by the Debugger and must not contain any application code when PMA is used in DEBUG mode.

2.19.1 ROM Debug Function

The debug function mainly consists of a debug handler and a single stepper. The debug handler processes the I²C communication and debug command interpretation. The debug commands **SetSFR**, **ReadSFR**, **SetData**, **ReadData** and **SetPC**, **ReadPC** are executed directly by the debug handler.

The debug commands **Single Step**, **Run Interruptible** and **Run until Breakpoint** are executed by the single stepper. The single stepper fetches the current opcode and enables opcode execution depending on the debug command.

2.19.2 DEBUG Mode Commands

In DEBUG mode the PMA51xx is accessible as a slave using the I²C interface.

Figure 77 shows the legend used for the description of the I²C commands.



	from debugger to PMA	S	start condition
	from PMA to debugger	P	stop condition
PCL	Program counter low byte	SR	restart condition or stop / start condition
PCH	Program counter high byte	A	acknowledge
BPL	Break point low byte	nA	not acknowledge
BPH	Break point high byte	Addr	SFR / idata / xdata address
Pause	Time where no communication is allowed	Data	Data byte read from / written to SFR / idata / xdata

Figure 77 Legend for I²C communication in DEBUG

2.19.2.1 Set SFR

Set an SFR to a user-defined value.



Figure 78 Set SFR command

Addr: Address of SFR to be set.

Data: Byte value that is written into the SFR address specified by *Addr*.

2.19.2.2 Read SFR

Read the value of one SFR.

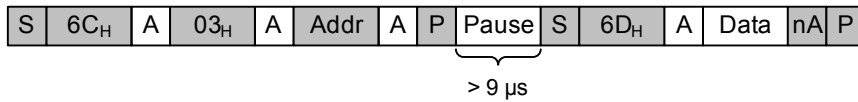

Figure 79 Read SFR command

Addr: Address of SFR to be read.

Data: Byte value that is read from the SFR at address specified by *Addr*.

2.19.2.3 Set IData

Set one byte in the internal data memory (RAM) to a user-defined value.

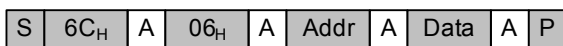

Figure 80 Set IData command

Addr: Address of the internal data memory to be set (Range: 00_H - FF_H).

Data: Byte value that is written into the internal data memory at address specified by *Addr*.

2.19.2.4 Read IData

Read one byte of the internal data memory (RAM).

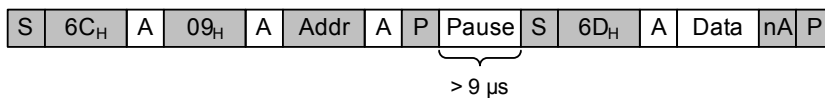

Figure 81 Read IData command

Addr: Address of the internal data memory to be read (Range: 00_H - FF_H).

Data: Byte value that is read from the internal data memory at address specified by *Addr*.

2.19.2.5 Set XData

Set one byte in the external data memory (battery buffered data RAM) to a user-defined value.



Figure 82 Set XData command

Addr: Address of the external data memory to be set (Range: 00_H - 0F_H).

Data: Byte value that is written into the external data memory at address specified by *Addr*.

2.19.2.6 Read XData

Read one byte of the external data memory (battery buffered data RAM).

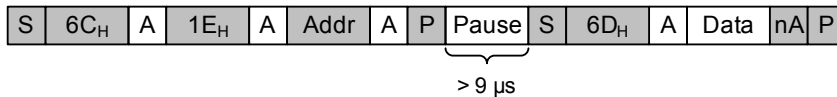

Figure 83 Read XData command

Addr: Address of the external data memory to be read (Range: 00_H - 0F_H).

Data: Byte value that is read from the external data memory at address specified by *Addr*.

2.19.2.7 Set PC

Set the Program Counter to a user-defined value.



Figure 84 Set PC command

PCL: MSB of the new Program Counter.

PCH: LSB of the new Program Counter.

2.19.2.8 Read PC

Reads the Program Counter.

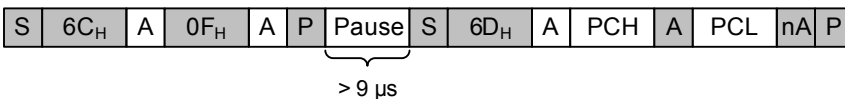

Figure 85 Read PC command

PCL: MSB of the actual Program Counter.

PCH: LSB of the actual Program Counter.

2.19.2.9 Single Step

Execute one opcode instruction and return to the debug handler.

Note: A Library function can not be single stepped and is stepped through automatically until the FLASH is re-entered.



Figure 86 Single Step

2.19.2.10 Run Interruptible

The function consists of device internal consecutive single steps until any I²C command is received on the bus. Compared to running the program in real time this function has a slower execution speed by a factor of about 1/50, dependent on the executed program.

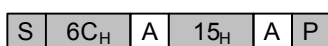

Figure 87 Run Interruptible

2.19.2.11 Run until Breakpoint

The debugged program is executed without single steps in real time. This enables debugging of runtime critical functions like RF-Transmission or LF data receiving. The execution is stopped when the PC matches the defined breakpoint.

Note: If the breakpoint is not hit the communication to the debugger is lost.

S	6C _H	A	18 _H	A	BPH	A	BPL	A	P
---	-----------------	---	-----------------	---	-----	---	-----	---	---

Figure 88 Run until Breakpoint

3 Reference

3.1 Electrical Data

3.1.1 Absolute Maximum Ratings

Attention: Stresses above the max. values listed here may cause permanent damage to the device. Exposure to absolute maximum rating conditions for extended periods may affect device reliability. Maximum ratings are absolute ratings; exceeding only one of these values may cause irreversible damage to the integrated circuit.

Attention: Test ■ means that the parameter is not subject to production test. It was verified by design/characterization.

Table 32 Absolute Maximum Ratings

Parameter	Symbol	Values			Unit	Note / Test Condition	Test	Number
		Min.	Typ.	Max.				
Supply Voltage	V_{Bat}	-0.3		+4.0	V		■	1.1
Operating Temperature	T_j	-40		+125	°C			1.2
ESD HBM integrity	V_{HBM}			2	kV	All pins According to ESD Standard JEDEC EIA / JESD22-A114-B	■	1.3
Latch up	I_{LU}	-100		+100	mA	EIA JESD78A	■	1.4
Input voltage at digital input pins	$V_{InDigital}$	-0.3		$V_{Bat}+0.3$	V			1.5
LF Receiver input voltage	V_{InLF}	-0.3		+0.3	V			1.6
Input and output current for digital I/O pins	I_{IOmax}			4	mA	Less than 10 mA on all digital pins	■	1.7
LF Receiver input current	I_{LFIN}			4	mA		■	1.8
XTAL input voltage	V_{InXT}	-0.3		$V_{REG}+0.3$	V		■	1.9
Storage Temperature	T_s	-40		+150 ¹⁾	°C	1) Max 1000 hours accumulated over lifetime	■	1.10

3.1.2 Operating Range

Within the operational range the IC operates as explained in the circuit description.

Table 33 Operating Range

Parameter	Symbol	Values			Unit	Note / Test Condition	Test	Number
		Min.	Typ.	Max.				
Supply voltage	V_{Bat1}	2.1		3.6	V	Temperature sensor, LF Receiver and FLASH programming		2.1
	V_{Bat2}	1.9		3.6	V	Every module which is not mentioned at 2.1 (V_{Bat1})		2.2
Ambient temperature range	T_{amb}	-40		125	°C	Normal operation		2.4
	T_{FLC}	0		85	°C	FLASH code sector programming		2.5
	T_{FLD}	-40		85	°C	FLASH data sector programming		2.6

3.1.3 Product Characteristics

Product characteristics involve the spread of values guaranteed within the specified voltage and ambient temperature range.

Typical characteristics are the median of the production.

Supply voltage: $V_{bat} = 1.9V \dots 3.6V$, unless otherwise specified

Ambient temperature: $T_{amb} = -40^{\circ}C \dots +125^{\circ}C$, unless otherwise specified

3.1.3.1 Temperature Sensor

Table 34 Temperature Sensor Characteristics

Parameter	Symbol	Values			Unit	Note / Test Condition	Test	Number
		Min.	Typ.	Max.				
Measurement error	T_{Error}	-3		+3	°C	$T = -20 \dots 70^{\circ}C$	■	3.1
Measurement error		-5		+5	°C	$T = T_j$	■	3.2

3.1.3.2 Battery Sensor

Table 35 Battery Sensor Characteristics

Parameter	Symbol	Values			Unit	Note / Test Condition	Test	Number
		Min.	Typ.	Max.				
Measurement error	V_{Error}	-100		100	mV		■	4.1

3.1.3.3 Supply Currents

Table 36 Supply Currents

Parameter	Symbol	Values			Unit	Note / Test Condition	Test	Number
		Min.	Typ.	Max.				
Supply Current RF Transmission FSK modulation	I_{5dBm}		9,7		mA	f = 315 MHz, $V_{Bat} = 3 V$, T = 25°C SFR DIVIC = 03 _H	■	5.1
	I_{8dBm}		12,2		mA		■	5.2
	I_{10dBm}		12,8		mA		■	5.3
Supply Current RF Transmission FSK modulation	I_{5dBm}		9,9		mA	f = 434 MHz, $V_{Bat} = 3 V$, T = 25°C SFR DIVIC = 03 _H	■	5.4
	I_{8dBm}		12,3		mA		■	5.5
	I_{10dBm}		13,8		mA		■	5.6
Supply Current RF Transmission FSK modulation	I_{5dBm}		11,8		mA	f = 868 MHz, $V_{Bat} = 3 V$, T = 25°C SFR DIVIC = 03 _H	■	5.7
	I_{8dBm}		12,9		mA		■	5.8
	I_{10dBm}		16,9		mA		■	5.9
Supply Current RF Transmission FSK modulation	I_{5dBm}		12,6		mA	f = 915 MHz, $V_{Bat} = 3 V$, T = 25°C SFR DIVIC = 03 _H	■	5.10
	I_{8dBm}		15,3		mA		■	5.11
	I_{10dBm}		17,1		mA		■	5.12
Supply Current RF Transmission FSK modulation	I_{5dBm}		8,9		mA	f = 315 MHz, $V_{Bat} = 3 V$, T = -40°C SFR DIVIC = 03 _H	■	5.13
	I_{8dBm}		11		mA		■	5.14
	I_{10dBm}		12		mA		■	5.15
Supply Current RF Transmission FSK modulation	I_{5dBm}		9,2		mA	f = 434 MHz, $V_{Bat} = 3 V$, T = -40°C SFR DIVIC = 03 _H	■	5.16
	I_{8dBm}		11,5		mA		■	5.17
	I_{10dBm}		12,9		mA		■	5.18
Supply Current RF Transmission FSK modulation	I_{5dBm}		11,3		mA	f = 868 MHz, $V_{Bat} = 3 V$, T = -40°C SFR DIVIC = 03 _H	■	5.19
	I_{8dBm}		12,8		mA		■	5.20
	I_{10dBm}		16,8		mA		■	5.21
Supply Current RF Transmission FSK modulation	I_{5dBm}		11,3		mA	f = 915 MHz, $V_{Bat} = 3 V$, T = -40°C SFR DIVIC = 03 _H	■	5.22
	I_{8dBm}		13,4		mA		■	5.23
	I_{10dBm}		16,7		mA		■	5.24
Supply Current RF Transmission FSK modulation	I_{5dBm}		10,9		mA	f = 315 MHz, $V_{Bat} = 3 V$, T = 125°C SFR DIVIC = 03 _H	■	5.25
	I_{8dBm}		13,1		mA		■	5.26
	I_{10dBm}		13,9		mA		■	5.27
Supply Current RF Transmission FSK modulation	I_{5dBm}		11,1		mA	f = 434 MHz, $V_{Bat} = 3 V$, T = 125°C SFR DIVIC = 03 _H	■	5.28
	I_{8dBm}		13,4		mA		■	5.29
	I_{10dBm}		15		mA		■	5.30
Supply Current RF Transmission FSK modulation	I_{5dBm}		12,3		mA	f = 868 MHz, $V_{Bat} = 3 V$, T = 125°C SFR DIVIC = 03 _H	■	5.31
	I_{8dBm}		11,6		mA		■	5.32
	I_{10dBm}		16,3		mA		■	5.33

Table 36 Supply Currents (cont'd)

Parameter	Symbol	Values			Unit	Note / Test Condition	Test	Number
		Min.	Typ.	Max.				
Supply Current RF Transmission FSK modulation	I_{5dBm}		13,3		mA	$f = 915 \text{ MHz}$, $V_{Bat} = 3 \text{ V}$, $T = 125^\circ\text{C}$ SFR DIVIC = 03 _H	■	5.34
	I_{8dBm}		14,8		mA		■	5.35
	I_{10dBm}		16,7		mA		■	5.36
Supply Current POWER DOWN	I_{PD}		590		nA	$V_{Bat} = 3.0\text{V}$, $T = 25^\circ\text{C}$		5.37
			10,8		μA	$V_{Bat} = 3.0\text{V}$, $T = 125^\circ\text{C}$	■	5.38
Supply Current IDLE	I_{IDLE}		0,80		mA	$V_{Bat} = 3.0\text{V}$, $T = 25^\circ\text{C}$ (SFR DIVIC = 00 _H , system clock = 12 MHz RC Osc.)		5.39
			0,93		mA	$V_{Bat} = 3.0\text{V}$, $T = 125^\circ\text{C}$ (SFR DIVIC = 00 _H , system clock = 12 MHz RC Osc.)	■	5.40
Supply Current RUN	I_{RUN}		1,87		mA	$V_{Bat} = 3.0\text{V}$, $T = 25^\circ\text{C}$ (SFR DIVIC = 00 _H , system clock = 12 MHz RC Osc.)		5.41
			2,0		mA	$V_{Bat} = 3.0\text{V}$, $T = 125^\circ\text{C}$ (SFR DIVIC = 00 _H , system clock = 12 MHz RC Osc.)	■	5.42

3.1.3.4 RF-Transmitter

The RF Transmitter is characterized on the evaluation board with 50 Ohm matching network for specified frequency. The schematic and the element values of the matching network can be found in [Figure 89 “Matching network for the power amplifier” on Page 196](#) and [Table 50 “Values of the matching network for the power amplifier” on Page 196](#). Tolerances of the passive elements not taken into account.

Table 37 RF Transmitter

Parameter	Symbol	Values			Unit	Note / Test Condition	Test	Number
		Min.	Typ.	Max.				
Transmit frequency	f_{TX}	300		320	MHz		■	6.1
		433		450	MHz			6.2
		865		870	MHz		■	6.3
		902		928	MHz		■	6.4
Data rate	DR_{RF}			32	kBps	$T = -40^\circ\text{C} - 85^\circ\text{C}$ (64 kChips/s)	■	6.5
				20	kBps	$T = -40^\circ\text{C} - 125^\circ\text{C}$ (40 kChips/s)	■	6.6
Output Power	OP_{RF}		5		dBm	$T = 25^\circ\text{C}$, $V_{BAT} = 3\text{V}$		6.7
			8		dBm	$T = 25^\circ\text{C}$, $V_{BAT} = 3\text{V}$		6.8
			10		dBm	$T = 25^\circ\text{C}$, $V_{BAT} = 3\text{V}$		6.9
Carrier to spurious ratio (incl. harmonics) @D1=315/915MHz				-28	dBc	FCC 15.231a/b/e 2 nd to 10 th harmonic RBW = 100kHz	■	6.10

Table 37 RF Transmitter (cont'd)

Parameter	Symbol	Values			Unit	Note / Test Condition	Test	Number
		Min.	Typ.	Max.				
Carrier to noise ratio @D1=315/915MHz				-20	dBc	FCC 15.231a/b/e RBW = 100kHz measured at frequency edge: 0,25%*f _C for 315MHz 0,5%*f _C for 915MHz f _C :carrier frequency	■	6.11
SSB Phase Noise @D1=315MHz			-95	-89	dBc/Hz	RBW = 100kHz, +25°C @ 10kHz offset,	■	6.12
			-93	-87	dBc/Hz	@ 100kHz offset,	■	6.13
			-120	-114	dBc/Hz	@ 1MHz offset,	■	6.14
			-136	-130	dBc/Hz	@ 10MHz offset	■	6.15
SSB Phase Noise @D1=434MHz			-93	-87	dBc/Hz	RBW = 100kHz, +25°C @ 10kHz offset,	■	6.16
			-90	-84	dBc/Hz	@ 100kHz offset,	■	6.17
			-113	-107	dBc/Hz	@ 1MHz offset,	■	6.18
			-132	-126	dBc/Hz	@ 10MHz offset	■	6.19
SSB Phase Noise @D1=868MHz			-87	-81	dBc/Hz	RBW = 100kHz, +25°C @ 10kHz offset,	■	6.20
			-85	-79	dBc/Hz	@ 100kHz offset,	■	6.21
			-110	-104	dBc/Hz	@ 1MHz offset,	■	6.22
			-134	-128	dBc/Hz	@ 10MHz offset	■	6.23
SSB Phase Noise @D1=915MHz			-86	-80	dBc/Hz	RBW = 100kHz, +25°C @ 10kHz offset,	■	6.24
			-85	-79	dBc/Hz	@ 100kHz offset,	■	6.25
			-109	-103	dBc/Hz	@ 1MHz offset,	■	6.26
			-135	-129	dBc/Hz	@ 10MHz offset	■	6.27

3.1.3.5 LF Receiver

The LF Receiver is only available on PMA5110.

Table 38 LF Receiver, V_{Bat} = 2.1-3.6V

Parameter	Symbol	Values			Unit	Note / Test Condition	Test	Number
		Min.	Typ.	Max.				
LF Baseband Sensitivity	S _{LF1}		2.5		mV _{pp}	After calling a Library function for calibration. T=25°C, V _{Bat} =3V	■	7.1
Data rate	DR _{LF}	2		4	kbit/s		■	7.2
Data rate error	DR _{error}	-2		2	%		■	7.3
Carrier frequency	f _{CLF}	120	125	130	kHz		■	7.4

Table 38 LF Receiver, $V_{Bat} = 2.1-3.6V$ (cont'd)

Parameter	Symbol	Values			Unit	Note / Test Condition	Test	Number
		Min.	Typ.	Max.				
LF Current consumption	I_{LF_AFE}		1		μA	25°C; 3 V Analog frontend only		7.5
	I_{LF_BB}		440		μA	25°C; 3 V Including baseband	■	7.6
Input dynamic range	DR_{LF}	70			dB	LF Baseband Sensitivity , AGC enabled	■	7.7
Differential input capacitance	C_{inLF}		15		pF	@125 kHz	■	7.8
Differential input resistance	R_{inLF}		500		kOhm	AGC disabled	■	7.9
Preamble length	$T_{preamble}$	2			ms	Included in reference datagram	■	7.10
Carrier Detector Freeze Hold Time	T_{CDCH}	2			s	Worst case @ 125°C	■	7.11

3.1.3.6 Crystal oscillator

Table 39 Crystal oscillator

Parameter	Symbol	Values			Unit	Note / Test Condition	Test	Number
		Min.	Typ.	Max.				
Crystal startup time	t_{XTAL}		1.2		ms	IFX Testboard with these Crystals ^{1) 2) 3) 4)}		8.1
Crystal oscillator startup delay time	$t_{XTALADJ}$	0		1750	μs	Programmable in 250 μs steps SFR XT CFG	■	8.2
Crystal frequency	f_{XTAL}	18		20	MHz			8.3
Parasitic capacitance	C_{PCBmax}			4	pF	Determined by PCB Layout	■	8.4
Serial resistance of the crystal	R_{Rmax}			60	Ohm			8.5
Input inductance XTALOUT	L_{OSC}		2.2		μH		■	8.6
Crystal fine tuning capacitance	C_{tune}		40		pF	Selectable with 156 fF resolution (8 bits)	■	8.7

- 1) NX5032SA EXS00A-CS00269 $C_L = 12pF$, $f_{Crystal} = 19,6875$ MHz
- 2) NX5032SA EXS00A-CS00270 $C_L = 12pF$, $f_{Crystal} = 19,0625$ MHz
- 3) NX5032SA EXS00A-CS00271 $C_L = 12pF$, $f_{Crystal} = 18,089583$ MHz
- 4) NX5032SA EXS00A-CS00272 $C_L = 12pF$, $f_{Crystal} = 18,080$ MHz

3.1.3.6.1 Crystal oscillator recommendation

As crystal oscillator for PMA51xx NX5032SD

Table 40 NDK crystal oscillator recommendation for PMA51xx

Nominal Frequency (MHz)	NDK specification number	Shunt capacitance (C_0)	Motional capacitance (C_1)
19.6875	EXS00A-02825	1.58pF±15%	6.73fF±15%
19.0625	EXS00A-03550	1.64pF±15%	6.97fF±15%
18.089583	EXS00A-03551	1.55pF±15%	6.50fF±15%
18.080	EXS00A-03552	1.60pF±15%	6.70fF±15%

3.1.3.7 12 MHz RC HF oscillator

Table 41 12 MHz RC HF oscillator

Parameter	Symbol	Values			Unit	Note / Test Condition	Test	Number
		Min.	Typ.	Max.				
Operating frequency	f_{RCHF}	-3%	12.00	+3%	MHz	$V_{Bat} = 3.0V, T = 25^{\circ}C$		9.1
Overall drift	df_{RCHF}	-5		+5	%			9.2

3.1.3.8 2 kHz RC LP oscillator

Table 42 2 kHz RC LP oscillator

Parameter	Symbol	Values			Unit	Note / Test Condition	Test	Number
		Min.	Typ.	Max.				
Operating frequency	f_{RCLP}	1.3	2	2.8	kHz	$V_{Bat} = 3.0V, T = 25^{\circ}C$		10.1
Overall drift	df_{RCLP}	-7		+7	%	Referring to nominal condition		10.2

3.1.3.9 Interval Timer

Table 43 Interval Timer

Parameter	Symbol	Values			Unit	Note / Test Condition	Test	Number
		Min.	Typ.	Max.				
Wake-up interval timer range	T_{WU}	0.05		255	s	Adjustable with resolution of 8 bit. Calibrated with Library Function.	■	11.1
Wake-up interval timer step	T_{WUST}	0.05		1	s		■	11.2
Frequency calibration error	f_{ITCE}	-5		+5	%	$T_{WUST} = 0.5s$, systemclock = XTAL	■	11.3

3.1.3.10 Power On Reset

Table 44 Power On Reset

Parameter	Symbol	Values			Unit	Note / Test Condition	Test	Number
		Min.	Typ.	Max.				
Power On Reset level	V_{POR}	0.2	0.4	1.7	V	Minimum supply voltage level measured at Pin V_{REG} for a valid logic LOW at Power On Reset circuit		12.1
Power On release level	V_{THR}	1.7		1.8	V	Measured at Pin V_{REG}		12.2
Power On reset time	t_{POR}	0.25	1	10	ms			12.3
Brown Out detect level in RUN state	V_{BRD}	1.7		1.8	V	Measured at Pin V_{REG}		12.4
Brown Out detect level in POWER DOWN	V_{PDBR}	0.7		1.7	V	Measured at Pin V_{REG}		12.5
Mode selection time	t_{MODE}			2.5	ms		■	12.6
Minimum detectable Brown Out glitch in RUN state	t_{brd}			1	μs		■	12.7
Minimum detectable Brown Out glitch in POWER DOWN	t_{brdpd}			100	μs		■	12.8

3.1.3.11 VMIN Detector

Table 45 VMIN Detector

Parameter	Symbol	Values			Unit	Note / Test Condition	Test	Number
		Min.	Typ.	Max.				
Low battery threshold warning level	TH_{LBat}	2.0	2.1	2.2	V			14.1

3.1.3.12 6k FLASH Code memory data

Table 46 6k FLASH Code memory data

Parameter	Symbol	Values			Unit	Note / Test Condition	Test	Number
		Min.	Typ.	Max.				
Temperature range Erase/program	TR_{FL}	0		85	°C			15.1
Erase/Program Supply voltage range regulated	V_{FLBat}	2.1			V			15.2
Endurance Data Retention	En_{FLCode}	1000			cycles	One cycle: Programming of all wordlines and erasing each sector once.	■	15.3
	$t_{RCode@125\text{ °C}}$	2			yrs		■	15.4
	$t_{RCode@85\text{ °C}}$	40			yrs		■	15.5
Erase time			102		ms	RC HF oscillator @12 MHz		15.6
Write time/line			2.2		ms	RC HF oscillator @12 MHz Line = 32 byte		15.7

3.1.3.13 2 times 128 byte FLASH Data memory

Table 47 2 times 128 byte FLASH Data memory

Parameter	Symbol	Values			Unit	Note / Test Condition	Test	Number
		Min.	Typ.	Max.				
Temperature range Erase/program	TR_{FL}	-40		85	°C			16.1
Erase/Program Supply voltage range regulated	V_{FLBat}	2.1			V			16.2

Table 47 2 times 128 byte FLASH Data memory (cont'd)

Parameter	Symbol	Values			Unit	Note / Test Condition	Test	Number
		Min.	Typ.	Max.				
Endurance	ER_{Data}	100	1000		kcycles	Over lifetime	■	16.3
Data Retention	$t_{RData@85\text{ °C}}$	40			yrs	Retention is a function of endurance.	■	16.4
	$t_{RData@125\text{ °C}}$	2			yrs		■	16.5
Erase time			102		ms	RC HF oscillator @12 MHz		16.6
Write time/line			2.2		ms	RC HF oscillator @12 MHz Line = 32byte		16.7

3.1.3.14 ADC Interface

The ADC Interface is only available on PMA5110.

Table 48 ADC Interface

Parameter	Symbol	Values			Unit	Note / Test Condition	Test	Number
		Min.	Typ.	Max.				
ADC input voltage range	VR_{ADC}	GND		V_{Reg}				17.1
ADC resolution	R_{ADC}	10			bit		■	17.2
Offset correction range	R_{OFFC}			6	bit		■	17.3
Differential non-linearity	DNL	-1.0		1.0	lsb			17.4
Integral non-linearity	INL	-1.5		1.5	lsb			17.5

3.1.3.15 Digital I/O Pin

Table 49 Digital I/O Pin

Parameter	Symbol	Values			Unit	Note / Test Condition	Test	Number
		Min.	Typ.	Max.				
Input low voltage	V_{IL}			0.5	V		■	18.1
Input high voltage	V_{IH}	$V_{Bat} - 0.5$			V		■	18.2
Output low voltage	V_{OL}			0.5	V	$I_{OL} = 1.6\text{mA}$		18.3
Output high voltage	V_{OH}	$V_{Bat} - 0.5$			V	$I_{OH} = -1.6\text{mA}$		18.4
Output transition time	t_{THL}, t_{TLH}			30	ns	20pF load, 10% ... 90%	■	18.5
Input capacitance	C_{pad}			2	pF		■	18.6
Internal pull-up or pull-down resistor	$R_{upPPx}, R_{downPPx}$ ¹⁾		50		kOhm			18.7
Internal pull-up or pull-down resistor	$R_{upPPy}, R_{downPPy}$ ²⁾		250		kOhm			18.8

1) PPx are: PP0, PP1

2) PPy are: PP2, PP3, PP4, PP5, PP6, PP7, PP8, PP9

3.1.4 Matching Network for the Power Amplifier

Figure 89 and Table 50 show the schematic and the element values of the matching network used for the characterization of the RF Transmitter.

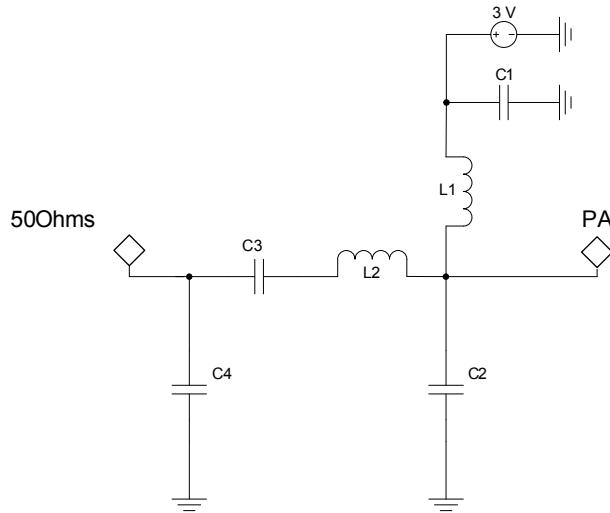

Figure 89 Matching network for the power amplifier

Table 50 Values of the matching network for the power amplifier

Frequency [MHz]	Output Power [dBm]	C1 [pF]	C2 [pF]	C3 [pF]	C4 [pF]	L1 [nH]	L2 [nH]
315	5	100	5,6	12	22	72	72
	8	100	5,6	12	15	72	72
	10	100	4,7	22	8,2	82	72
434	5	100	4,7	56	18	36	33
	8	100	4,7	39	12	36	36
	10	100	5,6	27	12	36	33
868	5	100	1,8	27	8,2	10	10
	8	100	1,8	33	6,8	10	10
	10	100	2,2	56	5,6	9,5	9,5
915	5	100	1,8	33	8,2	9,5	9,5
	8	100	2,2	27	6,8	9,5	9,5
	10	100	1,8	18	5,6	9,5	9,5

4 Register Overview

Table 51 Register Overview

Register Short Name	Register Long Name	Offset Address	Page Number
ACC	Accumulator	E0 _H	65
ADCC0	ADC Configuration Register 0	DB _H	116
ADCC1	ADC Configuration Register 1	DC _H	118
ADCDH	ADC Result Register high byte	D5 _H	119
ADCDL	ADC Result Register low byte	D4 _H	119
ADCM	ADC Mode Register	D2 _H	120
ADCOFF	ADC Input Offset c-network configuration	DA _H	121
ADCS	ADC Status Register	D3 _H	122
B	Register B	F0 _H	65
CFG0	Configuration Register 0	F8 _H	46
CFG1	Configuration Register 1	E8 _H	47
CFG2	Configuration Register 2	D8 _H	48
CRC0	CRC Shift Register low byte	AC _H	126
CRC1	CRC Shift Register high byte	AD _H	127
CRCC	CRC Control Register	A9 _H	125
CRCD	CRC Data Register	AA _H	126
DIVIC	Internal Clock Divider	B9 _H	54
DPH	Data Pointer (high byte)	83 _H	65
DPL	Data Pointer (low byte)	82 _H	65
DSR	Diagnosis and Status Register	D9 _H	49
ExtWUF	External Wake-up Flag Register	F1 _H	37
ExtWUM	External Wake-up Mask Register	F2 _H	38
FCSP	FLASH Control Register - Sector Protection Control	E9 _H	59
I2CB	I2C Baud rate Register	B1 _H	160
I2CC	I2C Control Register	A2 _H	161
I2CD	I2C Data Register	9A _H	162
I2CM	I2C Mode Register	A3 _H	162
I2CS	I2C Status Register	9B _H	163
IE	Interrupt Enable Register	A8 _H	69
IP	Interrupt Priority Register	B8 _H	70
IRQFR	Interrupt Request Flag Register for extended interrupts	8F _H	71
ITPH	Interval Timer Precounter Register High Byte	BB _H	43
ITPL	Interval Timer Precounter Register Low Byte	BA _H	44
ITPR	Interval Timer Period Register	BC _H	44

Table 51 Register Overview (cont'd)

Register Short Name	Register Long Name	Offset Address	Page Number
LBD	Low Battery Detector Control	EF _H	50
LFCDFlt	LF Carrier Detect Filtering	B2 _H	94
LFCDM	LF Carrier Detector Mode	B5 _H	95
LFDIV0	LF Division Factor low byte	B3 _H	96
LFDIV1	LF Division Factor high byte	B4 _H	96
LFOOT	LF On/Off Timer Configuration Register	C6 _H	97
LFOOTP	LF On/Off Timer Precounter	C5 _H	98
LFP0H	LF Pattern 0 Detector Sequence Data MSB	BF _H	98
LFP0L	LF Pattern 0 Detector Sequence Data LSB	BE _H	99
LFP1H	LF Pattern 1 Detector Sequence Data MSB	CF _H	99
LFP1L	LF Pattern 1 Detector Sequence Data LSB	CE _H	100
LFPCFG	LF Pattern Detection Configuration Register	C7 _H	100
LFRX0	LF Receiver Configuration Register 0	B7 _H	101
LFRX1	LF Receiver Configuration Register 1	B6 _H	102
LFRXC	LF Receiver Control Register	F9 _H	103
LFRXD	LF Receiver Data Register	A5 _H	104
LFRXS	LF Receiver Status Register	A4 _H	105
LFSYN0	LF Sync Pattern 0	A6 _H	106
LFSYN1	LF Sync Pattern 1	A7 _H	106
LFSYNCFG	LF SYNC Matching Configuration Register	AF _H	107
MMR0	Memory Mapped Register 0	84 _H	60
MMR1	Memory Mapped Register 1	85 _H	60
MMR2	Memory Mapped Register 2	86 _H	60
P1Dir	IO-Port 1 Direction Register	91 _H	150
P1In	IO-Port 1 Data IN Register	92 _H	152
P1Out	IO-Port 1 Data OUT Register	90 _H	153
P1SENS	IO-Port 1 Sensitivity Register	93 _H	154
P3Dir	IO-Port 3 Direction Register	EB _H	151
P3In	IO-Port 3 Data IN Register	EC _H	152
P3Out	IO-Port 3 Data OUT Register	B0 _H	153
P3SENS	IO-Port 3 Sensitivity Register	ED _H	155
PSW	Program Status Word	D0 _H	66
REF	Resume Event Flag Register	D1 _H	39
RFC	RF Transmitter Control Register	EE _H	77
RFD	RF Encoder TX Data Register	8E _H	77
RFENC	RF Encoder Tx Control Register	E7 _H	78
RFFSLD	RF Frequency Synthesizer Lock Detector Configuration	DF _H	79
RFFSPLL	RF Frequency Synthesizer PLL Configuration	D7 _H	80

Table 51 Register Overview (cont'd)

Register Short Name	Register Long Name	Offset Address	Page Number
RFS	RF Encoder Tx Status Register	E6 _H	81
RFTX	RF Transmitter Configuration Register	AE _H	82
RFVCO	RF Frequency Synthesizer VCO Configuration	DE _H	83
RNGD	Random Number Generator Data Register	AB _H	128
SP	Stack Pointer	81 _H	65
SPIB	SPI Baud rate Register	F3 _H	171
SPIC	SPI Control Register	F4 _H	172
SPID	SPI Data Register	F5 _H	173
SPIM	SPI Mode Register	F6 _H	173
SPIS	SPI Status Register	F7 _H	175
TCON	Timer Control Register Timer 0/1	88 _H	132
TCON2	Timer Control Register Timer 2/3	C8 _H	143
TH0	Timer 0 Register high byte	8C _H	133
TH1	Timer 1 Register high byte	8D _H	133
TH2	Timer 2 Register high byte	CD _H	144
TH3	Timer 3 Register high byte	CB _H	144
TL0	Timer 0 Register low byte	8A _H	134
TL1	Timer 1 Register low byte	8B _H	134
TL2	Timer 2 Register low byte	CC _H	145
TL3	Timer 3 Register low byte	CA _H	145
TMOD	Timer Mode Register	89 _H	135
TMOD2	Timer Mode Register 2 Timer 2/3	C9 _H	146
WUF	Wake-up Flag Register	C0 _H	40
WUM	Wake-up Mask Register	C1 _H	41
XTCFG	XTAL Configuration Register	C2 _H	56
XTAL1	XTAL Frequency Register FSKHIGH/ASK	C3 _H	55
XTAL0	XTAL Frequency Register FSKLOW	C4 _H	55

References

This section contains documents used for cross- reference throughout this document.

- [1] PMA Function Library Guide

5 Package Outlines

Dimensions are defined in millimeter.

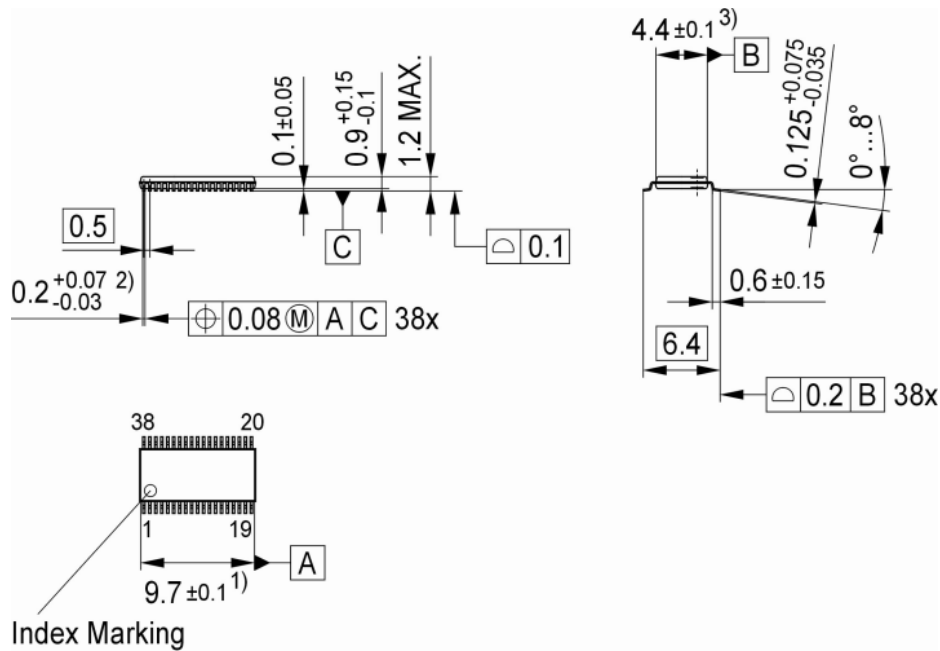

- 1) Does not include plastic or metal protrusion of 0.15 max. per side
- 2) Does not include dambar protrusion of 0.08 max. per side
- 3) Does not include plastic or metal protrusion of 0.25 max. per side

Figure 90 Package Outline PG-TSSOP-38

www.infineon.com

Published by Infineon Technologies AG