

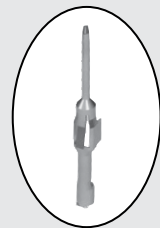

miniMATE®

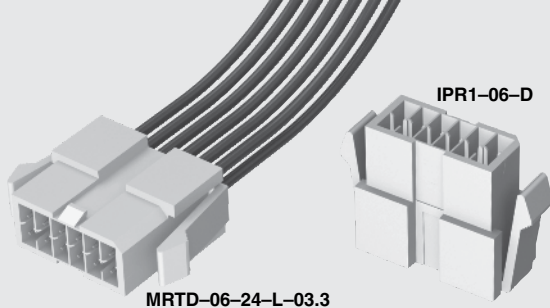

T1M74-L-01-F

(2.54 mm) .100"

MRTD, MRTDT, IPR1, T1M74-L, T1M74-R SERIES

PANEL MOUNT DISCRETE WIRE CABLE

Mates with:
MMSD(T)

SPECIFICATIONS

For complete specifications see www.samtec.com?MRTD or www.samtec.com?MRTDT

Insulator Material:

Nylon 66

Contact Material:

Phosphor Bronze

Plating:

Au or Sn over

50 μ" (1.27 μm) Ni

Operating Temp Range:

-40 °C to +105 °C (PVC)

-55 °C to +125 °C (*Teflon®)

Wire:

20 to 30 AWG

RoHS Compliant:

Yes

*DuPont™ Teflon® is a registered trademark of the E.I. du Pont de Nemours and Company or its affiliates.

RECOGNITIONS

For complete scope of recognitions see www.samtec.com/quality



Note:

Teflon® cable is intended for crimp only.

Contact Samtec for solderable cable applications.

TYPE	PINS PER ROW	WIRE GAUGE	PLATING OPTION	ASSEMBLY LENGTH	PINOUT
MRTD = Double Row PVC Cable	-02, -03, -04, -05, -06,	-20 -20C* (MRTD only)	-L = 10 μ" (0.25 μm) Gold on contact	- "XX.X" = Assembly Length in Inches Single ended = (76.2 mm) 03.0" min. Double ended = (84.0 mm) 03.3" min.	Leave blank for single ended cable assembly. -L1 = Plastic Transfer Latch up, straight -L4 = Plastic Transfer Latch down, straight
MRTDT = Double Row Blue *Teflon® Cable (20, 24, 28 & 30 AWG only)	-08, -10, -12, -15 (Standard sizes)	-22 -24 -24C* (MRTD only) -26 -28 -28C* (MRTD only) -30			

MRTD/MRTDT

MRTD/MRTDT

MRTD/MRTDT

APPLICATION

Note: Acceptable panel thickness of (0.84 mm) .0329" to (2.28 mm) .0897"

SPECIFICATIONS

For complete specifications see www.samtec.com?IPR1, www.samtec.com?T1M74-L or www.samtec.com?T1M74-R

RECOGNITIONS

For complete scope of recognitions see www.samtec.com/quality



TOOLING

- Hand Tool:
CAT-HT-174-2030-13
- Mini Applicator (20-24 AWG):
CAT-MC-174-2024-XX-01
- Mini Applicator (26-30 AWG):
CAT-MC-174-2630-XX-01
- Extraction Tool:
CAT-EX-74-01

TYPE	PINS PER ROW	D	TYPE	WIRE GAUGE	PLATING OPTION
IPR1 = Body, Loose	-02, -03, -04, -05, -06, -08, -10, -12, -15 (Standard sizes)	-D = Double Row	T1M74-L = Contact, Loose	-01 = 26 to 30 AWG -02 = 20 to 24 AWG	-F = Gold flash on contact -L = 10 μ" (0.25 μm) Gold on contact

IPR1

IPR1

Insulator Material: Nylon

T1M74-R
= Contact,
Full Reel
(15,300 Parts per Reel)

Contact Material: Phosphor Bronze