

**DESCRIPTION**

The LX1972A is a low cost silicon light sensor with a spectral response that closely emulates the human eye.

Patented circuitry produces peak spectral response at 580nm, with an IR response less than  $\pm 5\%$  of the peak response, above 900nm.

The photo sensor is a PIN diode array with Microsemi's *Best Eye*<sup>™</sup> processing that provides a nearly perfect photopic light wavelength response curve. LX1972A provides a linear, accurate, and very repeatable current transfer function. High gain current mirrors on the chip multiply the PIN diode photo-current to a sensitivity level that can be scaled with a standard value external resistor. Output current from this simple to use two-pin device can be used directly or converted to a voltage

by placing it in series with a single resistor at either of its two pins.

Dynamic range is determined by the resistors (typically in the range of 5K to 100K) and the power supply values. Typically the LX1972A needs only 2.7V of headroom to operate at 1000 Lux illumination.

Internal temperature compensation allows dark current to be kept below 200nA over the full specification temperature range ( $-40^{\circ}\text{C}$  to  $+85^{\circ}\text{C}$ ), providing high accuracy at low light levels. Usable ambient light conditions range is from 1 to more than 5000 Lux.

The LX1972A is optimized for controlling back lighting systems in low cost consumer products such as LCD TV, portable computers, and digital cameras.

**KEY FEATURES**

- Near Human Eye Spectral Response
- Very Low IR Sensitivity
- Highly Accurate & Repeatable Output Current vs. Light
- Scalable Output Voltage
- Temperature Stable
- Integrated High Gain Photo Current Amplifiers
- No Optical Filters Needed

**APPLICATIONS**

- Portable Electronic Displays
- LCD TV Backlight Systems
- Digital Still Cameras (DSC)
- Desk Top Monitors
- Notebook Computers

**IMPORTANT:** For the most current data, consult MICROSEMI's website: <http://www.microsemi.com>  
Protected By U.S. Patents: 6,787,757; Patents Pending

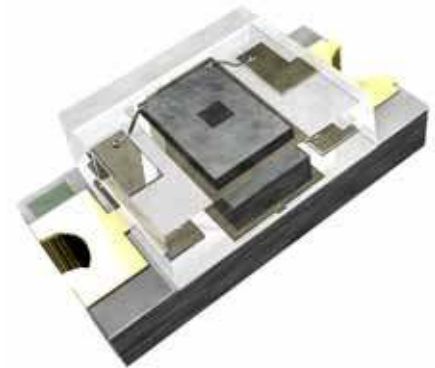
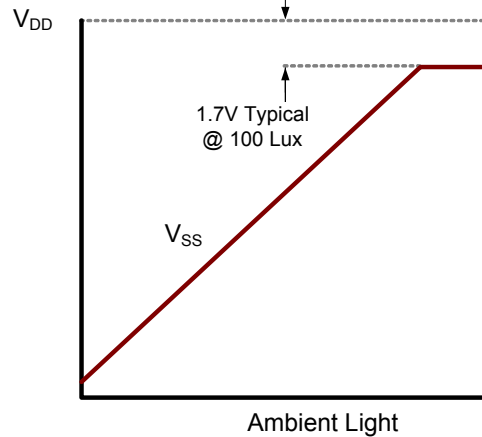
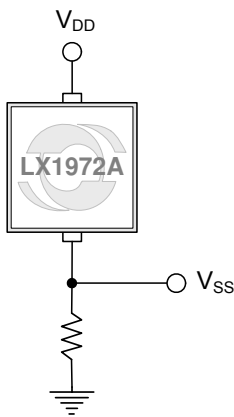
**PRODUCT HIGHLIGHT**

LX1972A

**PACKAGE ORDER INFO**

T <sub>A</sub> (°C)	<b>BC</b>	Plastic 1206 2-Pin
	RoHS Compliant / Pb-free	
-40 to 85	<b>LX1972AIBC</b>	

Note: Available in Tape & Reel. Append the letters "TR" to the part number. (i.e. LX1972AIBC-TR)

**ABSOLUTE MAXIMUM RATINGS**

Supply Input Voltage .....	-0.3V to 6V
Ground Current .....	Internally Limited
Operating Temperature Range .....	-40°C to 85°C
Maximum Operating Junction Temperature .....	150°C
Storage Temperature Range.....	-40°C to +100°C
Peak Package Solder Reflow Temp. (40 second max. exposure) ...	260°C (+0, -5)

Note: Exceeding these ratings could cause damage to the device. All voltages are with respect to Ground. Currents are positive into, negative out of specified terminal.

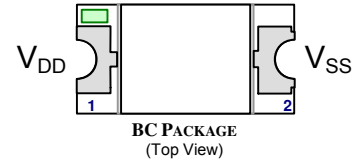
**PACKAGE PIN OUT**

RoHS / Pb-free Gold Lead Finish

**THERMAL DATA**
**BC Plastic 1206 2-Pin**

<b>THERMAL RESISTANCE-JUNCTION TO AMBIENT, <math>\theta_{JA}</math></b>	<b>850°C/W</b>
-------------------------------------------------------------------------	----------------

Junction Temperature Calculation:  $T_J = T_A + (P_D \times \theta_{JA})$ .

The  $\theta_{JA}$  numbers are guidelines for the thermal performance of the device/pc-board system. All of the above assume no ambient airflow.

**FUNCTIONAL PIN DESCRIPTION**

Name	Description
$V_{DD}$	Positive Terminal
$V_{SS}$	Negative Terminal

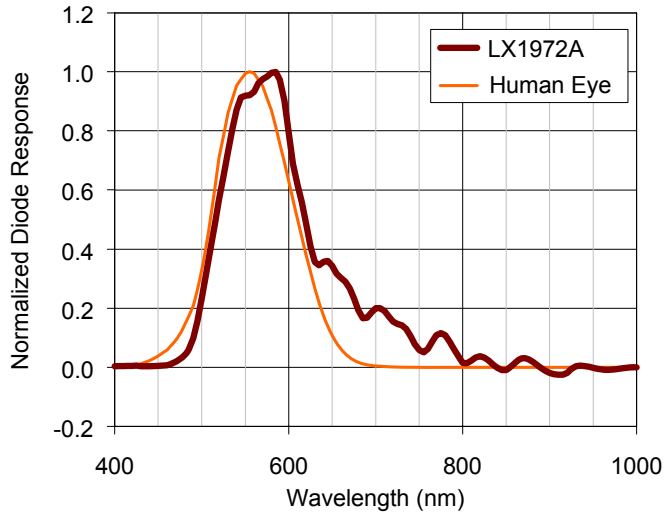
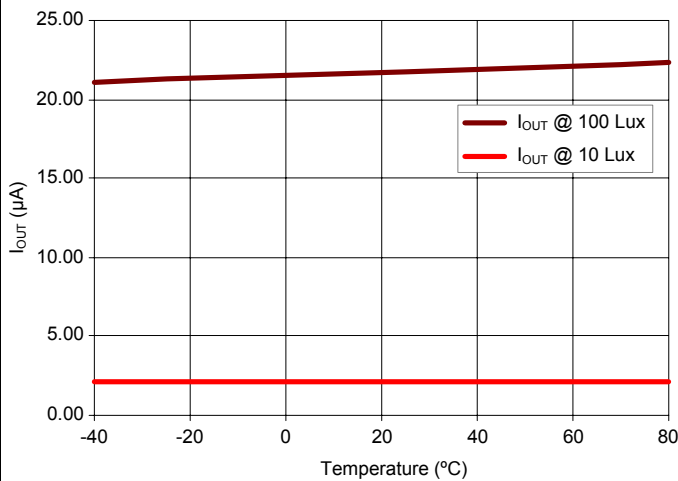
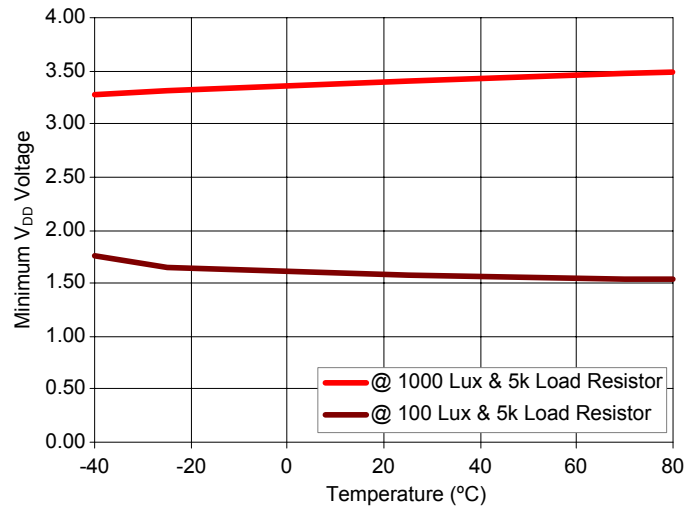
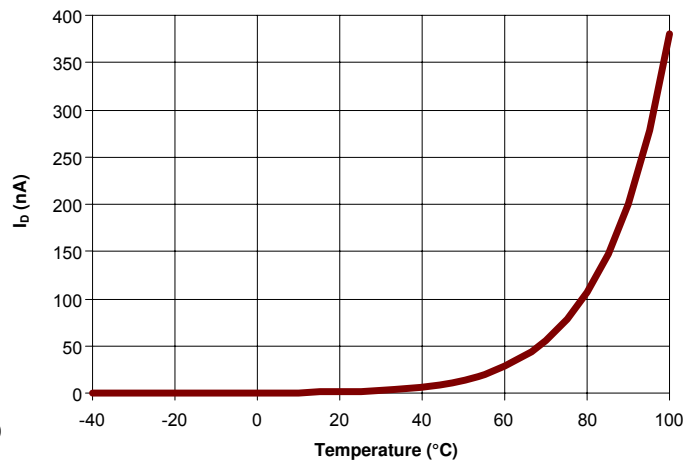
**CHARACTERISTIC CURVES**

**Chart 1 – Response vs. Wavelength**
 $I_{OUT}$  vs Temperature @ 10, 100 Lux

**Chart 3 –  $I_{OUT}$  vs. Temperature**

**Chart 2 – Minimum  $V_{DD}$  Voltage vs. Temperature**

**Chart 4 – Dark Current vs. Temperature**

**ELECTRICAL CHARACTERISTICS**

The following specifications apply over the operating ambient temperature  $-40^{\circ}\text{C} \leq T_A \leq 85^{\circ}\text{C}$  except where otherwise noted and with the following test conditions: See Note 1,  $V_{DD} = 5\text{V}$ ,  $R_{load} = 5\text{K}$

Parameter	Symbol	Test Conditions	LX1972A			Units
			Min	Typ	Max	
<b>RESPONSE</b>						
Peak Spectral Response	$\lambda_{PR}$			580		nm
Infrared Response	$\frac{I_{DD}(\lambda)}{I_{DD}(\lambda_{PR})}$	$E_{V(\text{white})} = 1000 \text{ Lux}$ , $E_{V(810\text{nm})} = 146\mu\text{W}/\text{cm}^2$ , Note 3	-5	1	5	%
Minimum Operational Voltage	$V_{DD}-V_{SS}$	$E_V = 100 \text{ Lux}$		1.4	2	V
		$E_V = 1000 \text{ Lux}$		2.2	2.7	
		$E_V = 2000 \text{ Lux}$		2.8	3	
Light Current	$I_{SS}$	$E_V = 10 \text{ Lux}$ , Note 2	1.8	2.4	3	$\mu\text{A}$
		$E_V = 100 \text{ Lux}$ , Note 2	18	24	30	
		$E_V = 1000 \text{ Lux}$ , Note 2	176	235	294	
		$E_V = 2000 \text{ Lux}$ , Note 2;	353	470	587	
Gain Linearity		$10 \text{ Lux} \leq E_V \leq 1000 \text{ Lux}$	-15		15	%
Dark Current	$I_{DD(\text{DARK})}$	$E_V = 0 \text{ Lux}$ , $T_A = 25^{\circ}\text{C}$ $E_V = 0 \text{ Lux}$		2	50	nA
Power Supply Rejection Ratio	PSRR	$V_{\text{RIPPLE}} = 10\text{mV}_{\text{P-P}}$ , $f = 10\text{kHz}$		-25		dB
Radiant Sensitive Area				0.04		$\text{mm}^2$

**Notes:**

1. The input irradiance ( $E_V$ ) is supplied from a white light-emitting diode (LED) optical source.
2. See Figure 1.
3. See Figure 2.

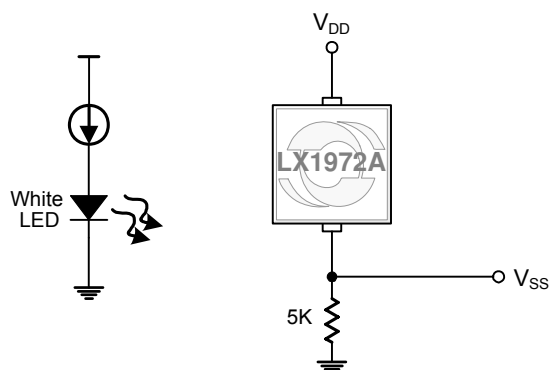
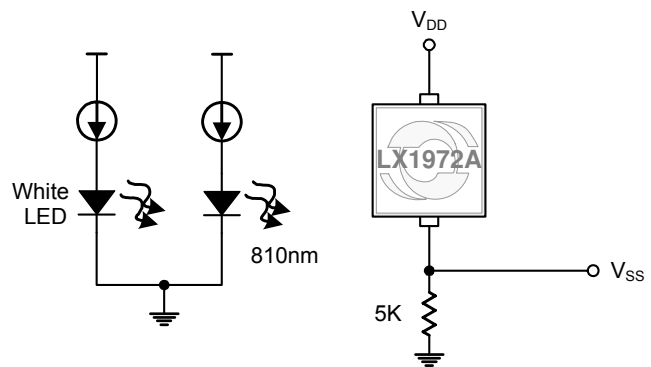
**TEST CIRCUITS**

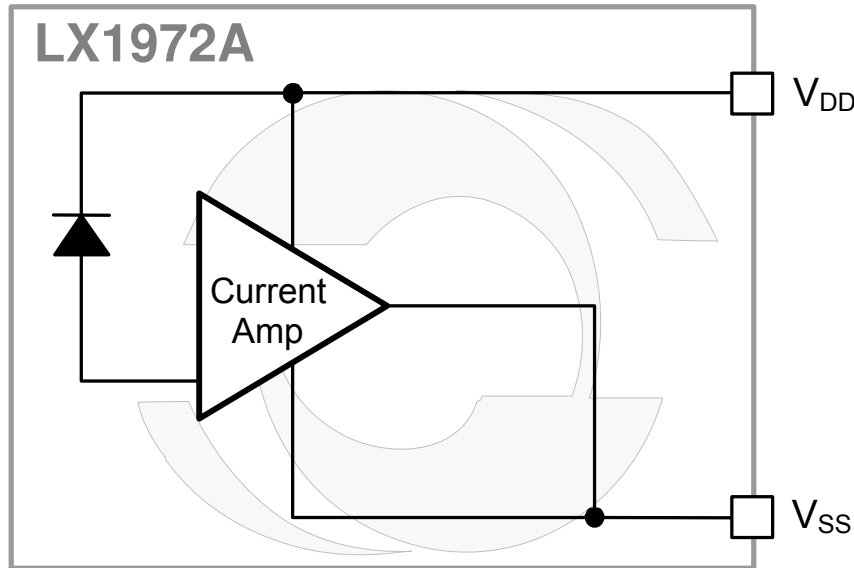
**Figure 1 – Operational Voltage Measurement Circuit**

**Figure 2 – IR Sensitivity Measurement Circuit**

**SIMPLIFIED BLOCK DIAGRAM**

**Figure 3 – Simplified Block Diagram**
**APPLICATION NOTE**
**LIGHT UNITS**

In converting from  $\mu\text{W}/\text{cm}^2$  to lux it is necessary to define the light source. Lux is a unit for the measurement of illuminance, which is the photometric flux density or visible light flux density. Whereas  $\mu\text{W}/\text{cm}^2$  is a measurement of irradiance or the measurement of electromagnetic radiation, flux both visible and invisible. The first step in the conversion process is to convert irradiance to illuminance, which essentially involves running the irradiant flux through a photopic filter. In normal ambient, a photopic curve is used and in dark ambient, a scotopic curve (dark adapted eye) is used. If the light is composed of only one wavelength, a conversion chart will tell the conversion factor to convert  $\mu\text{W}/\text{m}^2$  to lux (lumens/ $\text{m}^2$ ). If more than one wavelength is used, the light spectrum of the irradiance must be applied to the photopic filter to determine the resultant illuminance. The most sensitive wavelength for the normal light adapted human eye is 555nm, which corresponds to yellowish-green light. At 555nm, the conversion factor is  $683 \text{ Lux} = 1\text{W}/\text{m}^2 = 100\mu\text{W}/\text{cm}^2$ . Therefore  $14.6\mu\text{W}/\text{cm}^2 = 100 \text{ lux}$  at 555nm.

If the photo sensor had a truly photopic response, it would produce the same output current for the same number of lux, regardless of the color of the light. However, because the match is not perfect, there is still wavelength dependency particularly at the ends of the visible spectrum.

In the case of the LX1972A the peak photo response is at 580nm, however depending on the light source, what the human eye perceives as 'white' light may actually be composed of peak wavelengths of light other than 520nm. For instance, a typical fluorescent lamp includes dominant light not only near 550nm but also at 404 and 435nm. Incandescent light sources such as standard tungsten lights generate substantial IR radiation out beyond 2000nm.

For ease of automatic testing of the LX1972A the ATE (Automatic Test Equipment) light source is configured with white LEDs whose current is adjusted to output a calibrated flux density. This allows consistent and repeatable testing of the sensor but corresponds to a light source unlike that typically found in an office, home or sunlit environment. In practice, the user needs to place the sensor in the target environment and calibrate the sensors output current range to match the application objective. This is easily accomplished by adjusting the output resistor, which sets the sensor's gain.

**APPLICATION EXAMPLES**

The following examples present both fully automatic (no user input) and semi-automatic to fully manual override implementations. These general guidelines are applicable to a wide variety of potential light control applications. The LX1972A can be used to control the brightness input of CCFL inverters (like Microsemi's PanelMatch™ inverter family, or line of controller IC's). Likewise, it can interface well with LED drivers like the LX1990 and LX1991 sink LED drivers, or boost drivers like the LX1992, LX1993, LX1994, and LX1995.

In each specific application, it is important to recognize the need to correlate the output current of the LX1972A for the target environment and its ambient light conditions. The mechanical mounting of the sensor, light aperture hole size, use of a light pipe or bezel are critical in determining the response of the LX1972A for a given exposure of light.

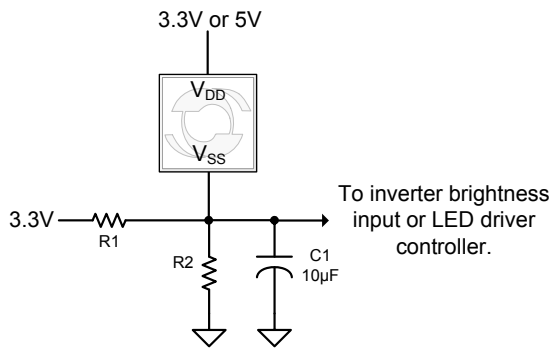
**Figure 4**

The example in figure 4 shows a fully automatic dimming solution with no user interaction. Choose R1 and R2 values for any desired minimum brightness and slope. Choose C1 to adjust response time to filter 50/60 Hz room lighting. As an example, let's say you wish to generate an output voltage from 0.25V to 1.25V to drive the input of an LED driver controller. The 0.25V represents the minimum LED brightness and 1.25V represents the maximum. The first step would be to determine the ratio of R1 and R2.

$$\frac{R2}{R1+R2} \times 3.3 = 0.25 \quad \therefore R1 = R2 \left[ \frac{3.3V}{0.25V} - 1 \right] = 12.2 \times R2$$

Next, the value of R2 can be calculated based on the maximum output source current coming from the LX1972A under the application's maximum light exposure, let's say this has been determined to be about 50µA. Thus R2 can be calculated first order as follows:

$$R2 = \left[ \frac{1.25V}{50\mu A} \right] = 25k \quad \therefore R1 = 12.2 \times R2 = 305k$$

The output node will actually reach 1.25V when the source current from the LX1972A is only about 43µA, since about 7µA of current will be contributed from R1. This assumes a high impedance input to the LED driver. In Figure 5 user adjustable bias control has been added to allow control over the minimum and maximum output voltage. This allows the user to adjust the output brightness to personal preference over a limited range. In addition, an equivalent DC voltage may replace the PWM input source.

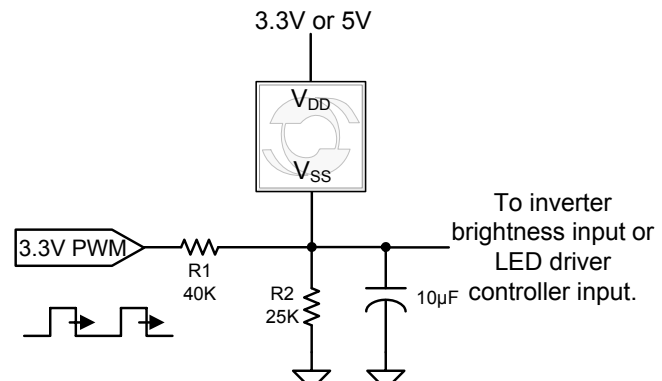
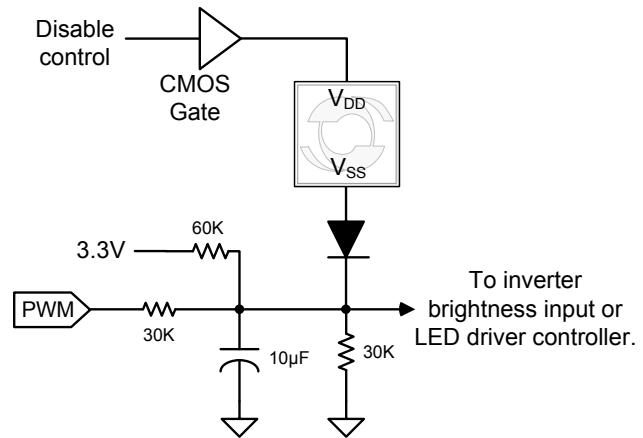
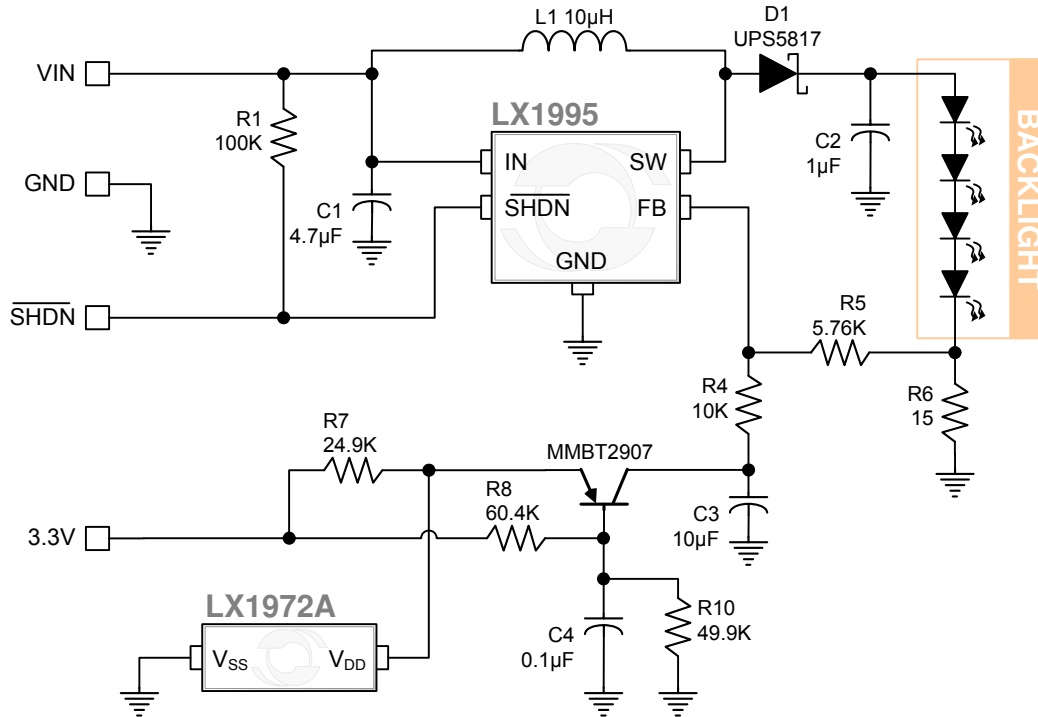
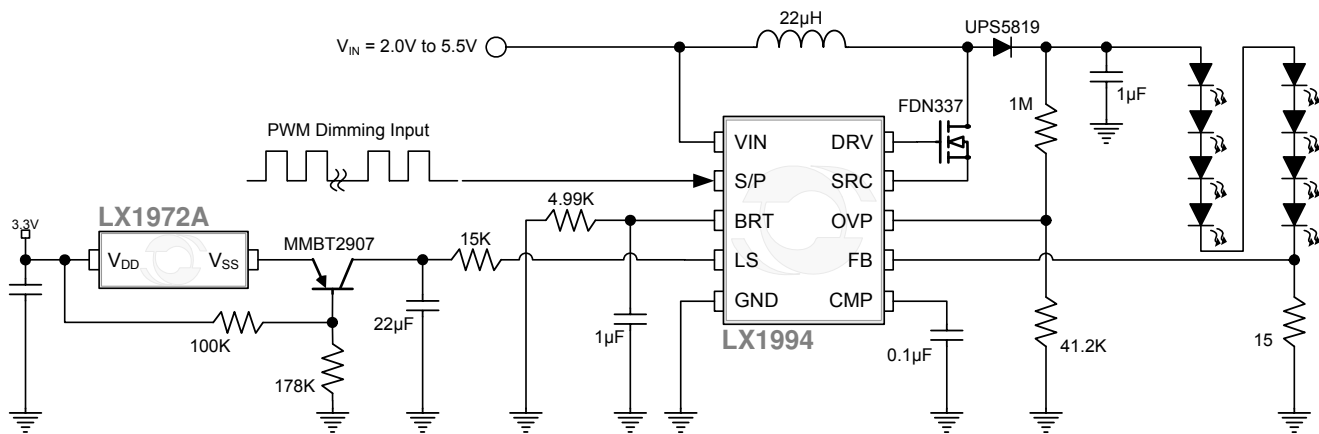
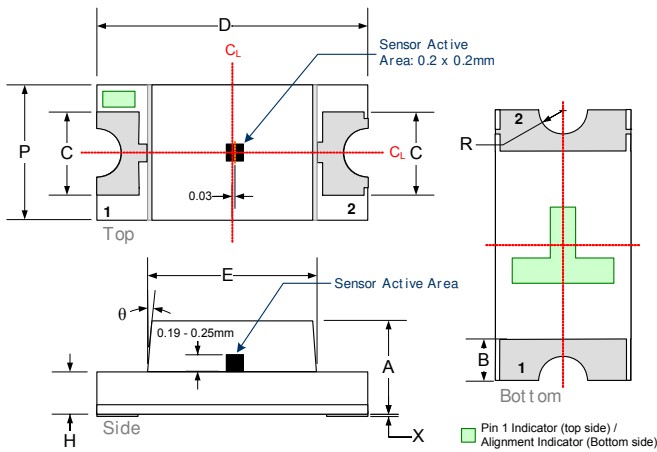

**Figure 5**

Figure 6 shows how a fully manual override can be quickly added to the example in figure 5. In addition to the gate to turn on and off the LX1972A, a diode has been inserted to isolate the sensor when it is disabled.

**Figure 6**

The preceding examples represent just a few of the potential sensor applications. Further details and additional circuits can be found in the application note (AN-28) LX1970 Visible Light Sensor located in the application section of [www.microsemi.com](http://www.microsemi.com). Although this application note is written around Microsemi's LX1970 visible light sensor, the circuits can be easily adapted for use with the LX1972A.

**APPLICATION CIRCUITS**

**Figure 7 – Typical Application with Microsemi's LX1995 LED Driver IC**

**Figure 8 – Typical Application with Microsemi's LX1994 LED driver IC**

**PACKAGE DIMENSIONS**
**BC 2-Pin 1206 Standard Carrier**

Dim	MILLIMETERS		INCHES	
	MIN	MAX	MIN	MAX
A	0.95	1.25	0.037	0.049
B	0.40	0.70	0.016	0.028
D	3.05	3.35	0.120	0.132
E	1.85	2.15	0.073	0.085
H	0.40	0.60	0.016	0.024
M	3° nom		3° nom	
P	1.45	1.75	0.057	0.069
R	0.25 nom		0.010 nom	
X	0.02	0.05	0.0008	0.002

**Note:**

Dimensions do not include protrusions; these shall not exceed 0.155mm (.006") on any side.

Recommended Soldering Pattern for reflow soldering of the BC (1206) package.

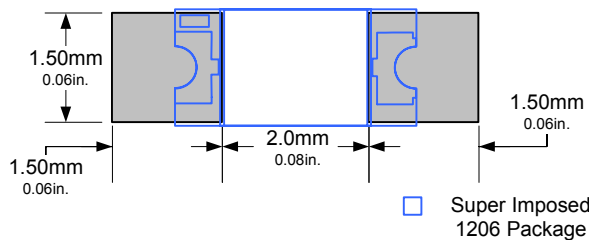

Basic specification is < 5 seconds @ 260°C when applying solder.

**Lead In:** 10 min empty  
**Loaded:** 3000 pcs  
**Lead Out:** 40 min empty

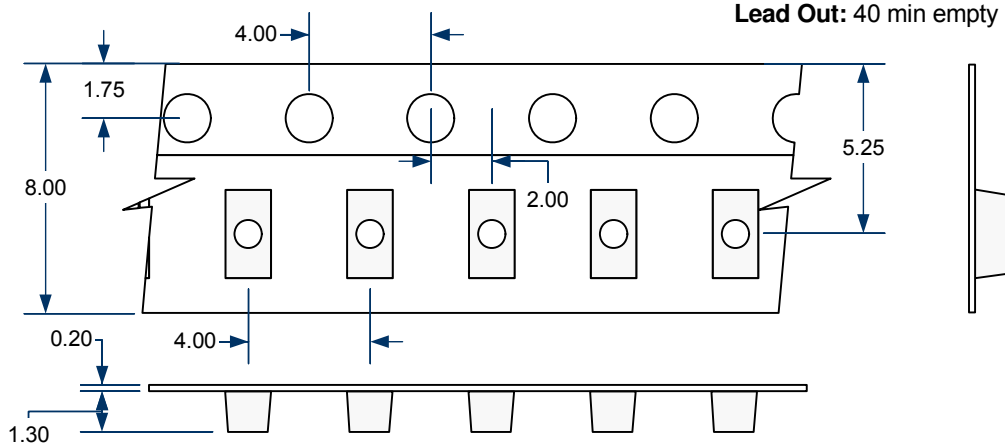





**Microsemi**<sup>®</sup>

**LX1972A**

**Ambient Light Detector**

**PRODUCTION DATA SHEET**

**NOTES**

PRODUCTION DATA – Information contained in this document is proprietary to Microsemi and is current as of publication date. This document may not be modified in any way without the express written consent of Microsemi. Product processing does not necessarily include testing of all parameters. Microsemi reserves the right to change the configuration and performance of the product and to discontinue product at any time.