

DO NOT
SCALE FROM
THIS PRINT

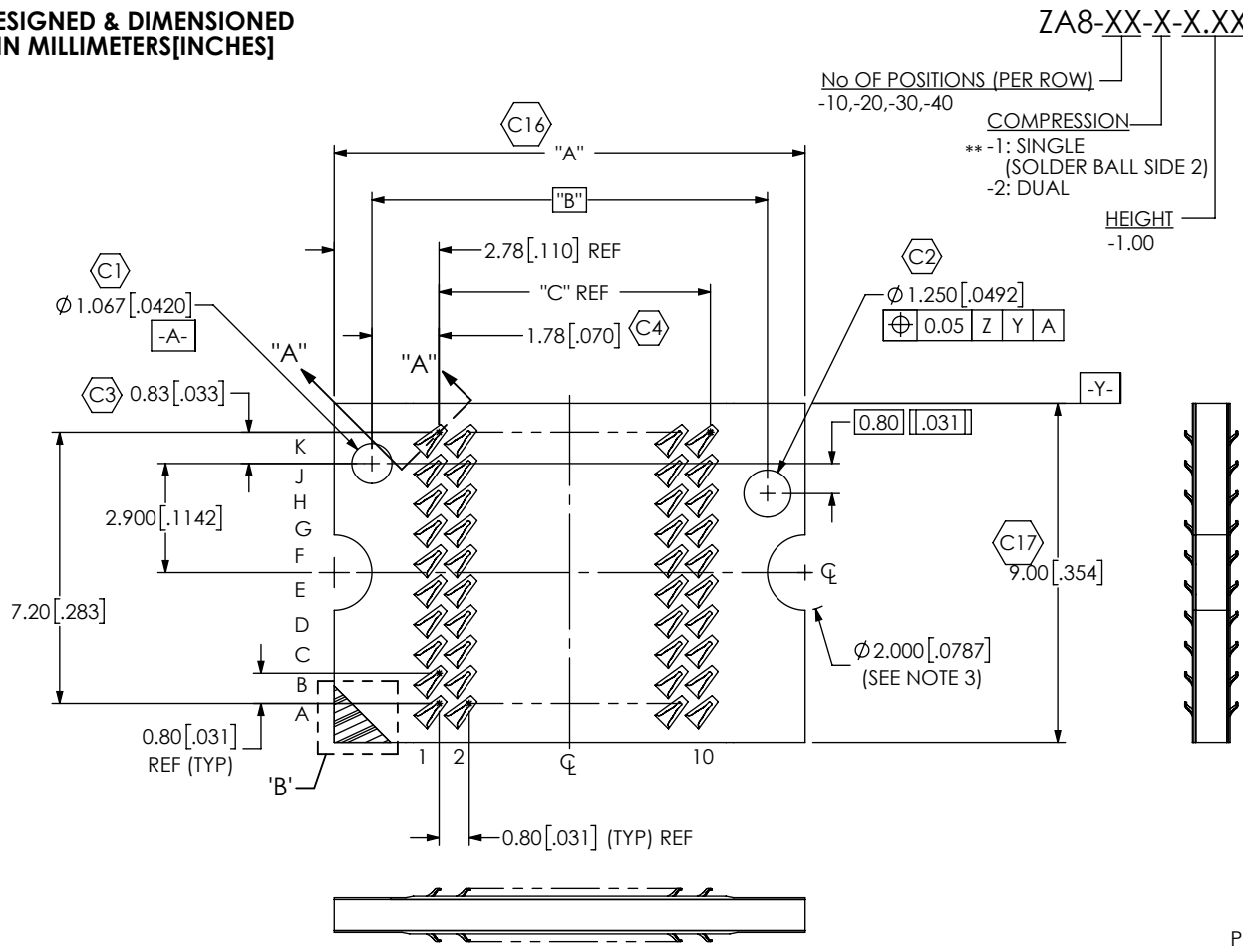

ZA8-XX-X-X.XX-X-XX-X

No OF POSITIONS (PER ROW)
-10,-20,-30,-40

COMPRESSION
** -1: SINGLE (SOLDER BALL SIDE 2)
-2: DUAL

HEIGHT
-1.00

SOLDER COMPOSITION
LEAVE BLANK FOR -2 DUAL COMPRESSION
-1: LEAD (63% Sn/37% Pb)
-2: LEAD-FREE (96.5% Sn/3% Ag/.5% Cu)

ROW SPECIFICATION
-10: 10 ROWS

PLATING SPECIFICATION
-Z: 6µ" MIN Au (C15) OVER 40-100µ" Ni (C14)
* -S: 30µ" MIN Au (C15) OVER 40-100µ" Ni (C14)
* NOT RELEASED
** ONLY AVAILABLE IN -10 & -20 POSITIONS
-30 & -40 POSITION NOT RELEASED

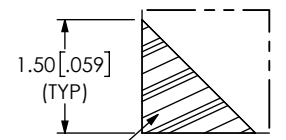
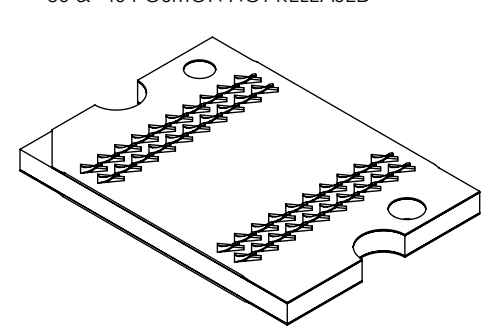

POSITION 1 INDICATOR THROUGH COVERFILM ONLY
DETAIL 'B'
SCALE 10 : 1

FIG 1
ZA8-10-2-1.00-X-10 SHOWN
(DUAL COMPRESSION)
(SOME CENTER FEATURES REMOVED FOR CLARITY)

No OF POS	"A"	"B"	"C"
-10	12.50 [.492]	10.500 [.4134]	7.20 [.283]
-20	20.50 [.807]	18.500 [.7283]	15.20 [.598]
-30	31.70 [1.248]	29.700 [1.1693]	26.40 [1.039]
-40	39.70 [1.563]	37.700 [1.4843]	34.40 [1.354]

- NOTES:
- ① REPRESENTS A CRITICAL DIMENSION.
 - CONTACT POINTS ARE MEASURED IN UNCOMPRESSED STATE.
 - RECOMMENDED SCREW SIZE: M1.6.
 - ELECTRICAL TEST: 100% ISOLATION & CONTINUITY TESTS REQUIRED
100% HI-POT REQUIRED AT 300V
MINIMUM PIN TO PIN ISOLATION TO BE 200 MEGA OHMS.
 - PARTS TO BE PACKAGED IN TRAYS.
 - DIMENSION AFTER FINAL REFLOW IS 1.000 [.0394].
 - MAXIMUM BURR AFTER DICING: 0.125 [.005].
 - PARTS TO BE PROCESSED PER SAMTEC WORKMANSHIP GUIDELINE: NA-ZR-WI-3015-M.
 - PAD SIZE IS DEFINED BY SOLDERMASK OPENING; SOLDERMASK THICKNESS IS .0254MM +/- .0127MM.
 - TOTAL STACK HEIGHT OF MATERIAL LAYERS IS REPRESENTED IN CONTACT ARRAY AREA. AREAS OUTSIDE OF THE ARRAY HAVE THE FOIL LAYER REMOVED RESULTING IN THINNER PROFILE DIMENSION OUTSIDE OF ARRAY.
 - INSPECTION IS OF THE CENTER AND HIGHEST POINT (POINT OF CONTACT) INSPECT OPPOSING CORNER LOCATIONS ONLY BOTH SIDES.

UNLESS OTHERWISE SPECIFIED, DIMENSIONS ARE IN MILLIMETERS. TOLERANCES ARE: DECIMALS ANGLES X.X: ±0.3 [.01] 2° X.XX: ±0.13 [.005] X.XXX: ±0.051 [.0020]	PROPRIETARY NOTE THIS DOCUMENT CONTAINS CONFIDENTIAL AND PROPRIETARY INFORMATION AND ALL DESIGN, MANUFACTURING, REPRODUCTION, USE, PATENT RIGHTS AND SALES RIGHTS ARE EXPRESSLY RESERVED BY SAMTEC, INC. THIS DOCUMENT SHALL NOT BE DISCLOSED, IN WHOLE OR PART, TO ANY UNAUTHORIZED PERSON OR ENTITY NOR REPRODUCED, TRANSFERRED OR INCORPORATED IN ANY OTHER PROJECT IN ANY MANNER WITHOUT THE EXPRESS WRITTEN CONSENT OF SAMTEC, INC.	520 PARK EAST BLVD., NEW ALBANY, IN 47150 PHONE: 812-944-6733 FAX: 812-948-5047 e-Mail: info@SAMTEC.com code 53322

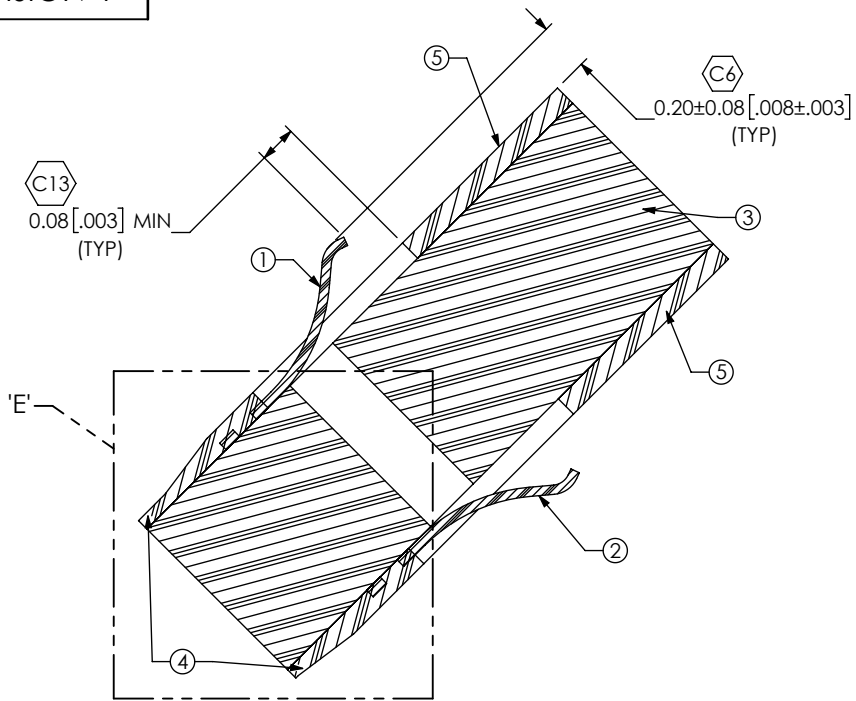

SECTION "A"- "A"
SCALE 32 : 1

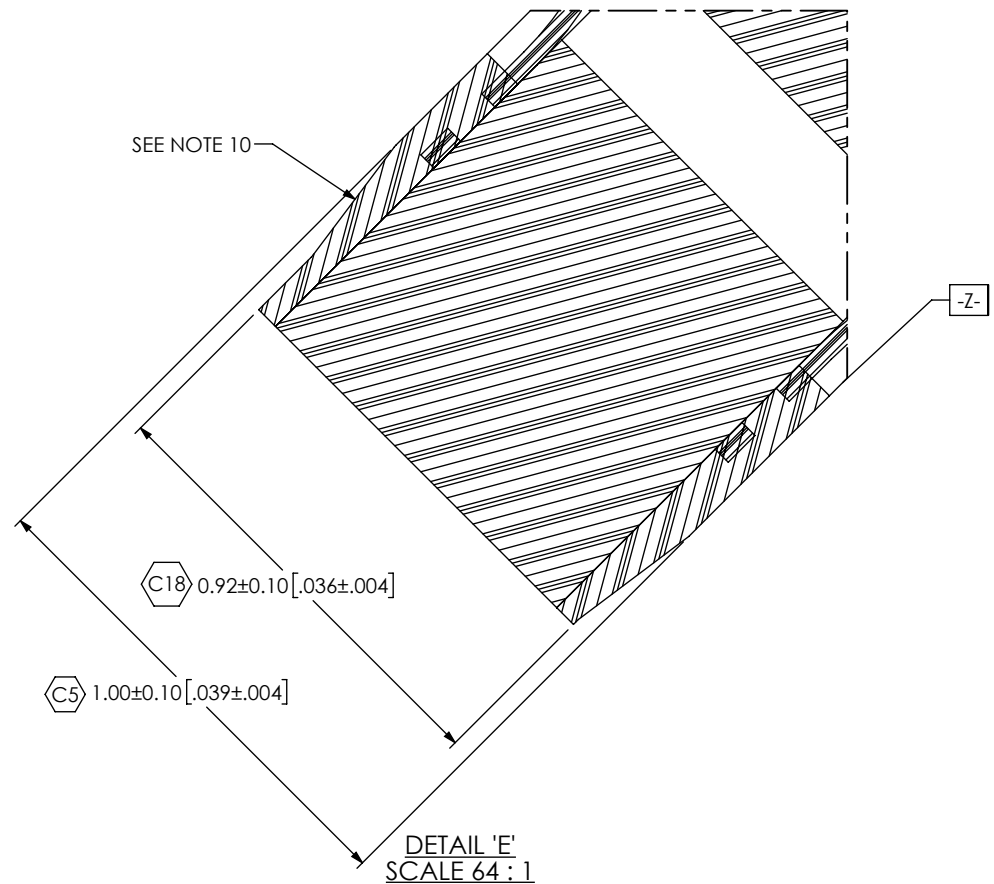

DETAIL 'E'
SCALE 64 : 1

ZA8-XX-2-X.XX-X-XX BOM

ITEM NO.	PART NUMBER	DESCRIPTION	10X10 QTY	20X10 QTY	30X10 QTY	40X10 QTY	MATERIAL
1	FOIL-0001-NS-01	CONTACT	.01042	.01563	.03125	.03125	BeCu
2	FOIL-0001-FS-01	CONTACT	.01042	.01563	.03125	.03125	BeCu
3	PCB-(SEE TABLE 2)	CORE	.01042	.01563	.03125	.03125	FR4
4	FR1515-6X9-0001	BOND PLY	.02084	.03126	.06250	.06250	ADHESIVE/POLYIMIDE FILM
5	ZCF-BL03-FR01-1209-BK	COVERFILM	.01042	.01563	.03125	.03125	ADHESIVE/POLYIMIDE FILM
6	TY-ZA800X (SEE TABLE 2)	TRAY	.02083	.02381	.02778	.03333	RPET (CLEAR)

TABLE 2

No OF POS	COMPRESSION	PCB-106100-ZA8-XX-XX-01	CAM DATA	TRAY
-10	-2	PCB-106100-ZA8-10-10-01	ZR-00002	TY-ZA8001
-20	-2	PCB-106100-ZA8-20-10-01	ZR-00003	TY-ZA8003
-30	-2	PCB-106100-ZA8-30-10-01	ZR-00004	TY-ZA8002
-40	-2	PCB-106100-ZA8-40-10-01	ZR-00005	TY-ZA8004

PROPRIETARY NOTE

THIS DOCUMENT CONTAINS CONFIDENTIAL AND PROPRIETARY INFORMATION AND ALL DESIGN, MANUFACTURING, REPRODUCTION, USE, PATENT RIGHTS AND SALES RIGHTS ARE EXPRESSLY RESERVED BY SAMTEC, INC. THIS DOCUMENT SHALL NOT BE DISCLOSED, IN WHOLE OR PART, TO ANY UNAUTHORIZED PERSON OR ENTITY NOR REPRODUCED, TRANSFERRED OR INCORPORATED IN ANY OTHER PROJECT IN ANY MANNER WITHOUT THE EXPRESS WRITTEN CONSENT OF SAMTEC, INC.

DO NOT SCALE DRAWING

SHEET SCALE: 4:1



520 PARK EAST BLVD, NEW ALBANY, IN 47150
PHONE: 812-944-6733 FAX: 812-948-5047
e-Mail: info@SAMTEC.com code 55322

DESCRIPTION: Z-RAY 0.8 mm PITCH DUAL COMP

DWG. NO. ZA8-XX-X-X.XX-X-XX-X

BY: D.SCHMELZ 10/29/2013 SHEET 2 OF 6

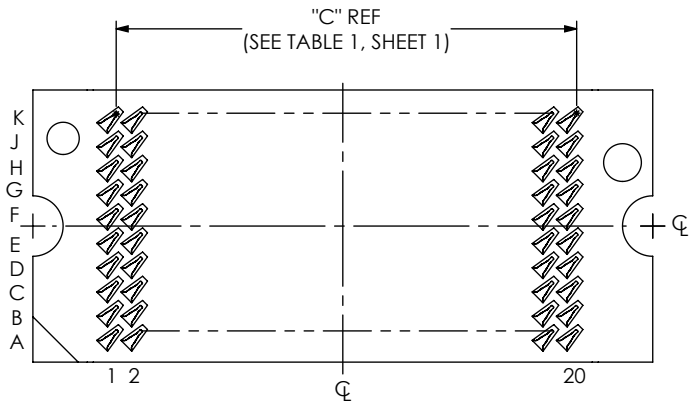

FIG 2
 ZA8-20-2-1.00-X-10 SHOWN
 (DUAL COMPRESSION)
 (DIFFERENT AS SHOWN, OTHERWISE SAME AS FIG 1)
 (SOME CENTER FEATURES REMOVED FOR CLARITY)

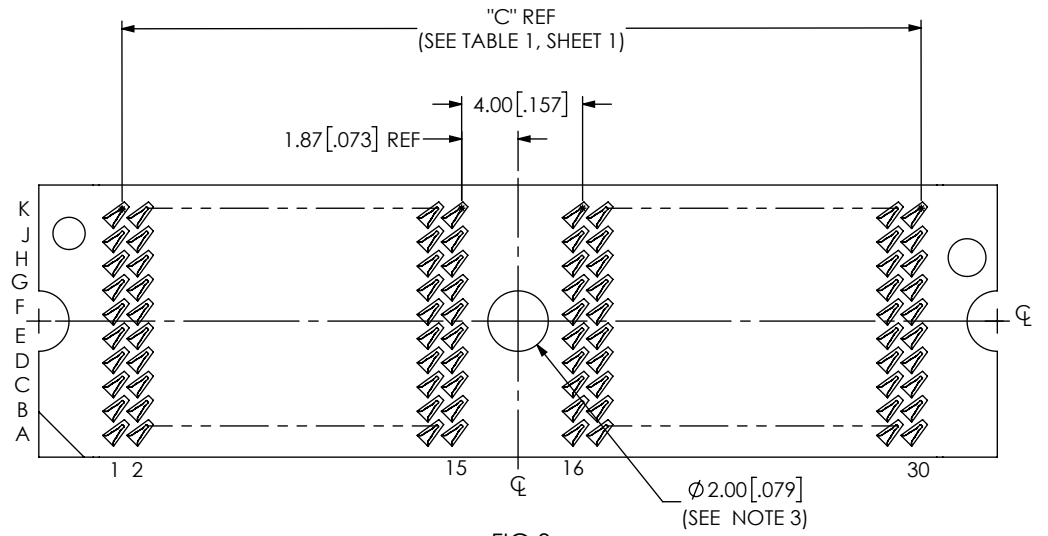

FIG 3
 ZA8-30-2-1.00-X-10 SHOWN
 (DUAL COMPRESSION)
 (DIFFERENT AS SHOWN, OTHERWISE SAME AS FIG 1)
 (SOME CENTER FEATURES REMOVED FOR CLARITY)

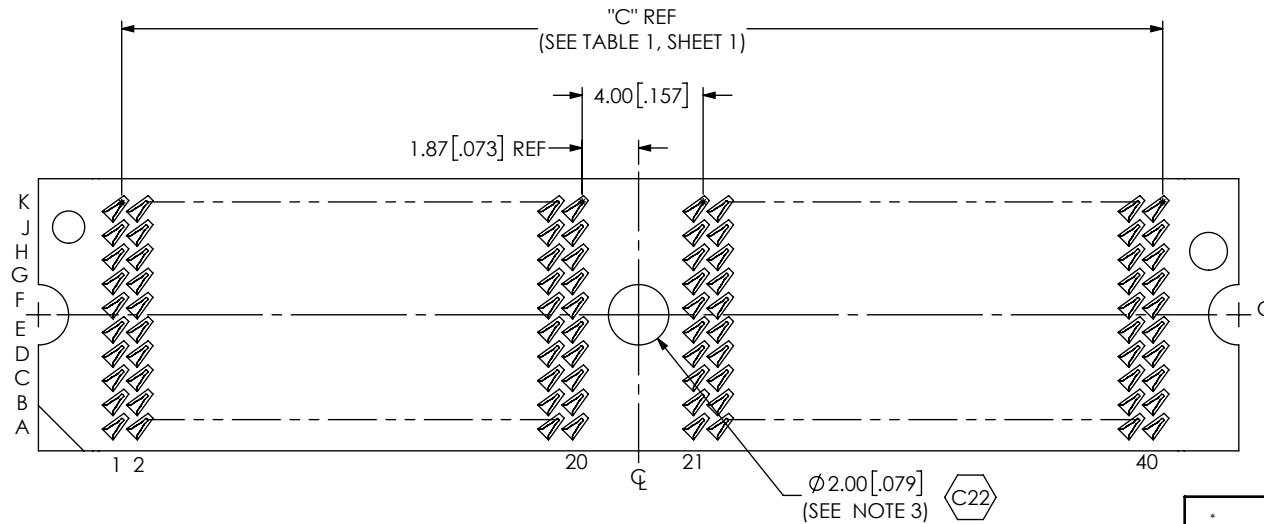

FIG 4
 ZA8-40-2-1.00-X-10 SHOWN
 (DUAL COMPRESSION)
 (DIFFERENT AS SHOWN, OTHERWISE SAME AS FIG 1)
 (SOME CENTER FEATURES REMOVED FOR CLARITY)

PROPRIETARY NOTE
 * THIS DOCUMENT CONTAINS CONFIDENTIAL AND PROPRIETARY INFORMATION AND ALL DESIGN, MANUFACTURING, REPRODUCTION, USE, PATENT RIGHTS AND SALES RIGHTS ARE EXPRESSLY RESERVED BY SAMTEC, INC. THIS DOCUMENT SHALL NOT BE DISCLOSED, IN WHOLE OR PART, TO ANY UNAUTHORIZED PERSON OR ENTITY NOR REPRODUCED, TRANSFERRED OR INCORPORATED IN ANY OTHER PROJECT IN ANY MANNER WITHOUT THE EXPRESS WRITTEN CONSENT OF SAMTEC, INC.

DO NOT SCALE DRAWING

SHEET SCALE: 4:1



520 PARK EAST BLVD. NEW ALBANY, IN 47150
 PHONE: 812-944-6733 FAX: 812-948-5047
 e-Mail info@SAMTEC.com code 55322

DESCRIPTION:
 Z-RAY 0.8 mm PITCH DUAL COMP

DWG. NO.
ZA8-XX-X-X.XX-X-XX-X

BY: D.SCHMELZ 10/29/2013 SHEET 3 OF 6

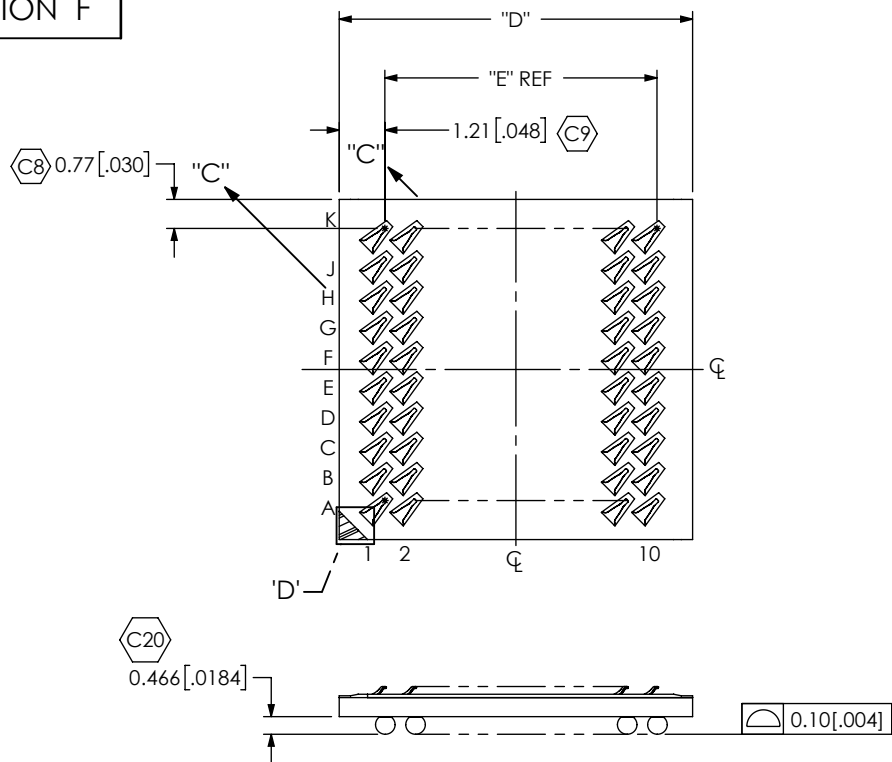

C20

0.466 [0.0184]

0.10 [0.004]

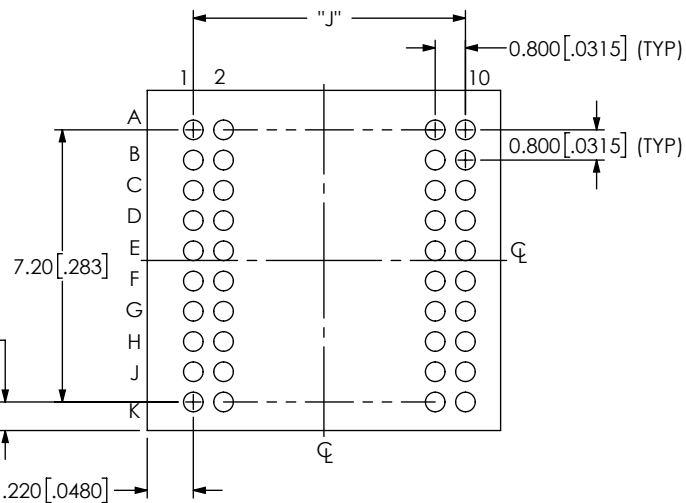
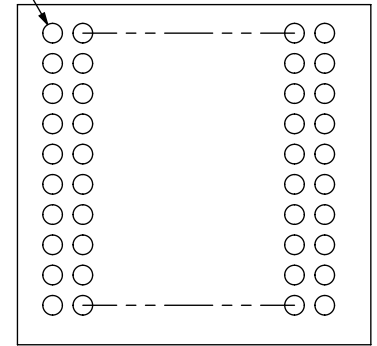

FIG 5

ZA8-10-1-1.00-X-10-X SHOWN
(SINGLE COMPRESSION)

(DIFFERENT AS SHOWN, OTHERWISE SAME AS FIG 1)
(SOME CENTER FEATURES REMOVED FOR CLARITY)

$\varnothing 0.34 \pm 0.06$ [0.013 \pm 0.002]
(SOLDERMASK OPENING)
(SEE NOTE 9)



IN PROCESS

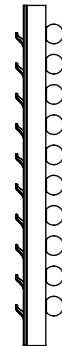

0.75 [0.030]
(TYP)



POSITION 1 INDICATOR
THROUGH COVERFILM ONLY

DETAIL 'D'
SCALE 10 : 1

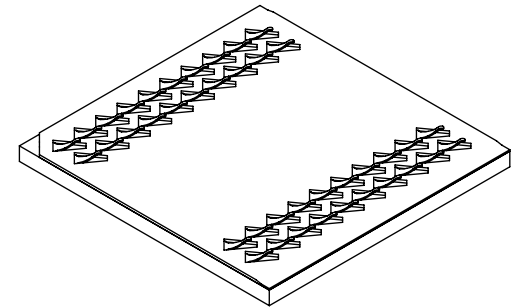

TABLE 4

No OF POS	"D"	"E"	"F"	"G"	"J"
-10	9.35 [368]	7.200 [2835]	N/A	N/A	7.200 [2835]
-20	17.35 [683]	15.200 [5984]	N/A	N/A	15.200 [5984]
-30	30.15 [1.187]	28.000 [1.1024]	11.200 [4.409]	18.020 [7.094]	28.000 [1.1024]
-40	38.15 [1.502]	36.000 [1.4173]	15.200 [5.984]	22.020 [8.669]	36.000 [1.4173]

PROPRIETARY NOTE

THIS DOCUMENT CONTAINS CONFIDENTIAL AND PROPRIETARY INFORMATION AND ALL DESIGN, MANUFACTURING, REPRODUCTION, USE, PATENT RIGHTS AND SALES RIGHTS ARE EXPRESSLY RESERVED BY SAMTEC, INC. THIS DOCUMENT SHALL NOT BE DISCLOSED, IN WHOLE OR PART, TO ANY UNAUTHORIZED PERSON OR ENTITY NOR REPRODUCED, TRANSFERRED OR INCORPORATED IN ANY OTHER PROJECT IN ANY MANNER WITHOUT THE EXPRESS WRITTEN CONSENT OF SAMTEC, INC.

DO NOT SCALE DRAWING

SHEET SCALE: 5:1

samtec

520 PARK EAST BLVD, NEW ALBANY, IN 47150
PHONE: 812-944-6733 FAX: 812-948-5047
e-Mail info@SAMTEC.com code 55322

DESCRIPTION:
Z-RAY 0.8 mm PITCH DUAL COMP

DWG. NO.
ZA8-XX-X-X.XX-X-XX-X

BY: D.SCHMELZ 10/29/2013 SHEET 4 OF 6

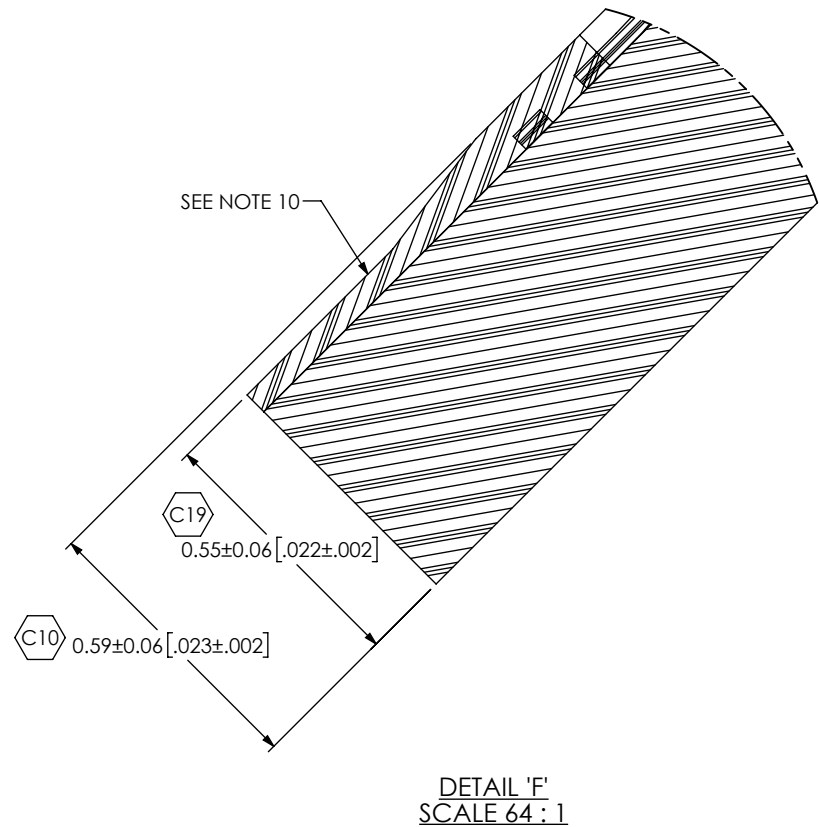
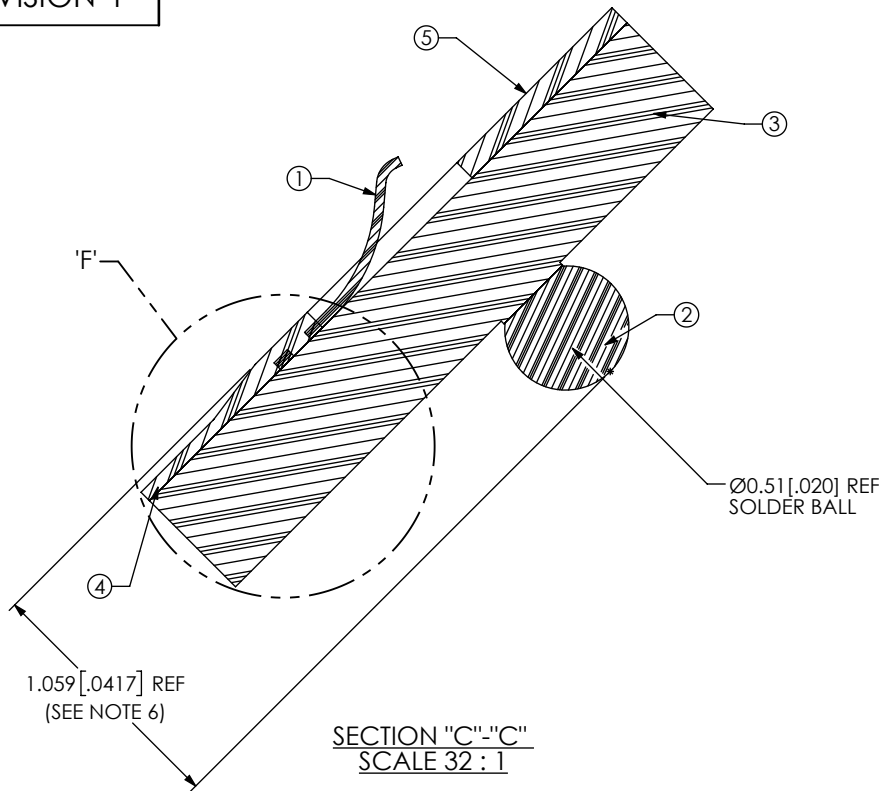

ZA8-XX-1-X.XX-X-XX-X BOM							
ITEM NO.	PART NUMBER	DESCRIPTION	10X10 QTY	20X10 QTY	30X10 QTY	40X10 QTY	MATERIAL
1	FOIL-0001-NS-01	CONTACT	.00781	.01563	.03125	.03125	BeCu
2	SDB-(SEE TABLE 5)	SOLDER BALL	100	200	300	400	SEE CALLOUT
3	PCB-(SEE TABLE 3)	CORE	.00781	.01563	.03125	.03125	FR4
4	LF1535-6X9-0001	BOND FLY	.00781	.01563	.03125	.03125	ADHESIVE/POLYIMIDE FILM
5	ZCF-BL03-FR01-1209-BK	COVERFILM	.00391	.00782	.01563	.01563	ADHESIVE/POLYIMIDE FILM
6	PPP-77-09.00	P & P PAD	1	1	1	1	LCP
7	TY-ZA800X (SEE TABLE 3)	TRAY	.02220	.02860	.03330	.04000	RPET (CLEAR)

TABLE 5	
SOLDER COMPOSITION	SDB-020-XXXX
-1	SDB-020-6337
-2	SDB-020-9653

TABLE 3				
No OF POS	COMPRESSION	PCB-XXXXXX-ZA8-XX-XX-01	CAM DATA	TRAY
-10	-1	PCB-106391-ZA8-10-10-01	ZR-00006	TY-ZA8005
-20	-1	PCB-106391-ZA8-20-10-01	ZR-00007	TY-ZA8006
-30	-1	PCB-106391-ZA8-30-10-01	ZR-00008	TY-ZA8007
-40	-1	PCB-106391-ZA8-40-10-01	ZR-00009	TY-ZA8008

PROPRIETARY NOTE
 THIS DOCUMENT CONTAINS CONFIDENTIAL AND PROPRIETARY INFORMATION AND ALL DESIGN, MANUFACTURING, REPRODUCTION, USE, PATENT RIGHTS AND SALES RIGHTS ARE EXPRESSLY RESERVED BY SAMTEC, INC. THIS DOCUMENT SHALL NOT BE DISCLOSED, IN WHOLE OR PART, TO ANY UNAUTHORIZED PERSON OR ENTITY NOR REPRODUCED, TRANSFERRED OR INCORPORATED IN ANY OTHER PROJECT IN ANY MANNER WITHOUT THE EXPRESS WRITTEN CONSENT OF SAMTEC, INC.

DO NOT SCALE DRAWING

SHEET SCALE: 5:1



520 PARK EAST BLVD. NEW ALBANY, IN 47150
 PHONE: 812-944-6733 FAX: 812-948-5047
 e-Mail info@SAMTEC.com code 55322

DESCRIPTION: Z-RAY 0.8 mm PITCH DUAL COMP
 DWG. NO. ZA8-XX-X-X.XX-X-XX-X
 BY: D.SCHMELZ 10/29/2013 SHEET 5 OF 6

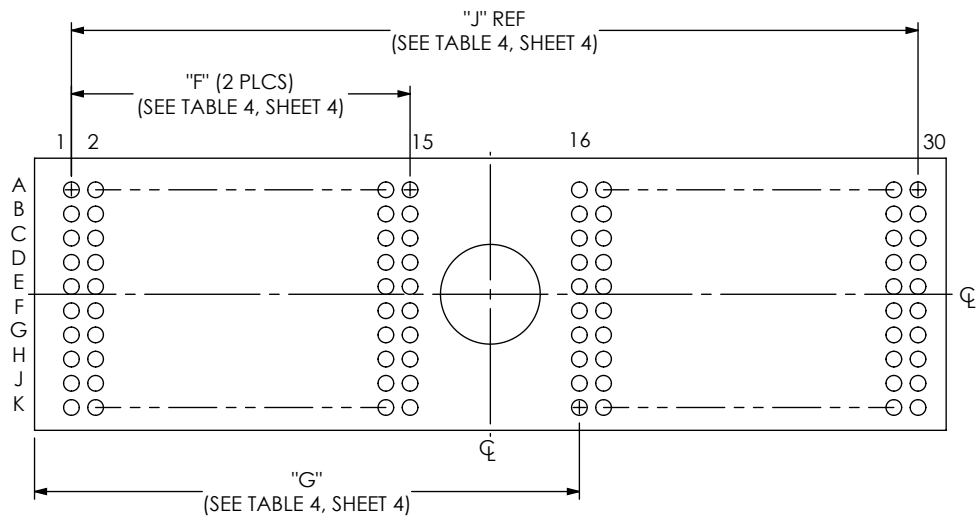
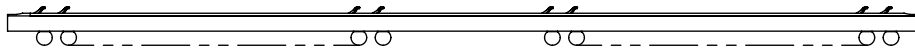
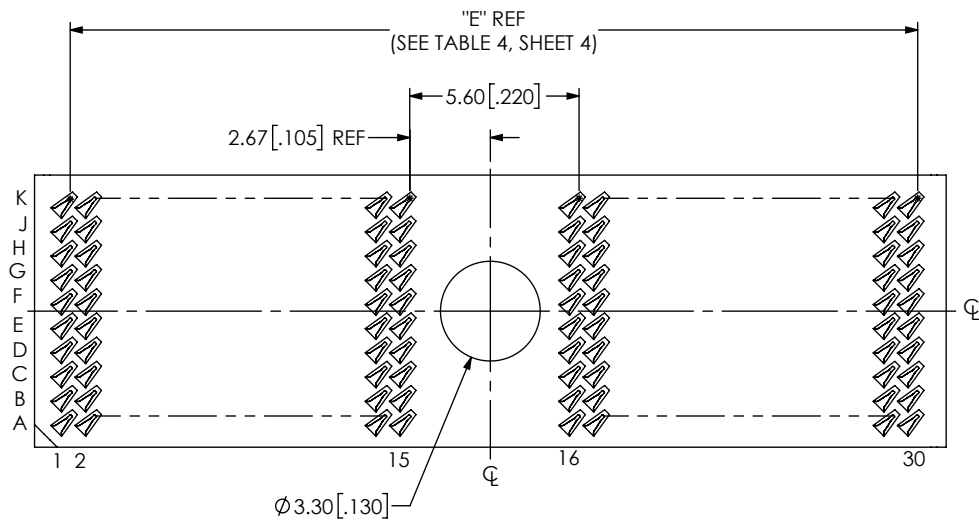

FIG 6
 ZA8-30-1-1.00-X-10-X SHOWN
 (SINGLE COMPRESSION)
 (DIFFERENT AS SHOWN, OTHERWISE SAME AS FIG 5)
 (ALSO APPLIES TO ZA8-40)
 (SOME CENTER FEATURES REMOVED FOR CLARITY)

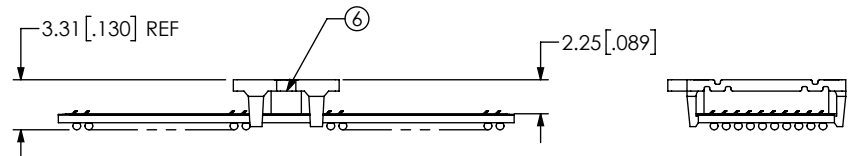
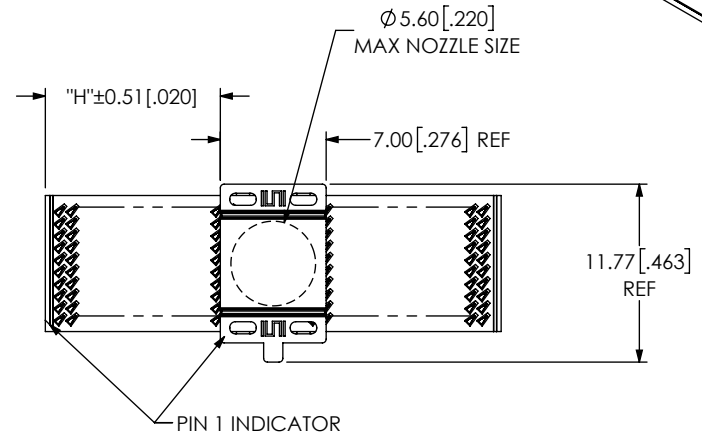
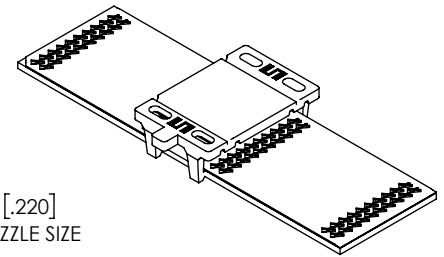

FIG 7
 ZA8-30-1-1.00-X-10-X SHOWN
 (SINGLE COMPRESSION WITH PPP)
 (DIFFERENT AS SHOWN, OTHERWISE SAME AS FIG 2)
 (SOME CENTER FEATURES REMOVED FOR CLARITY)

No OF POS	"H"
-10	1.17 [.046]
-20	5.17 [.204]
-30	11.57 [.456]
-40	15.57 [.613]

PROPRIETARY NOTE
 THIS DOCUMENT CONTAINS CONFIDENTIAL AND PROPRIETARY INFORMATION AND ALL DESIGN, MANUFACTURING, REPRODUCTION, USE, PATENT RIGHTS AND SALES RIGHTS ARE EXPRESSLY RESERVED BY SAMTEC, INC. THIS DOCUMENT SHALL NOT BE DISCLOSED, IN WHOLE OR PART, TO ANY UNAUTHORIZED PERSON OR ENTITY NOR REPRODUCED, TRANSFERRED OR INCORPORATED IN ANY OTHER PROJECT IN ANY MANNER WITHOUT THE EXPRESS WRITTEN CONSENT OF SAMTEC, INC.

DO NOT SCALE DRAWING

SHEET SCALE: 4:1

samtec

520 PARK EAST BLVD. NEW ALBANY, IN 47150
 PHONE: 812-944-6733 FAX: 812-948-5047
 e-Mail info@SAMTEC.com code 55322

DESCRIPTION:
 Z-RAY 0.8 mm PITCH DUAL COMP

DWG. NO.
ZA8-XX-X-X.XX-X-XX-X

BY: D.SCHMELZ 10/29/2013 SHEET 6 OF 6