

## Digital Temperature Measurement System

### DESCRIPTION

The DC2531 is the starter kit for demonstrating the performance and ease of use of the [LTC®2986](#), which is a complete temperature measurement system on a chip. This kit includes the DC2508 (main demo circuit containing the LTC2986) and the DC2210 (a simple experiment circuit allowing bread boarding). In addition to the starter demonstration kit, sensor specific demonstration boards highlighting the performance of RTDs, thermistors, or thermocouples are also available.

- Universal Temperature Measurement Board – DC2211
- Thermocouple Board – DC2212
- Dedicated RTD Board – DC2213
- Dedicated Thermistor Board – DC2214

The DC2508 is a member of the QuikEval™ family of demonstration boards. It is designed to allow easy evaluation of the LTC2986 and may be connected to any one of the sensor daughter boards.

These daughter boards allow evaluation of the various LTC2986 sensor types (see Figure 1).

For the serial digital interface, the DC2508 may be connected to the DC2026 Linduino™ One.

**Design files for this circuit board are available at <http://www.linear.com/demo/DC2531>**

LT, LT, LTC, LTM, Linear Technology and the Linear logo are registered trademarks and QuikEval and Linduino are trademarks of Linear Technology Corporation. All other trademarks are the property of their respective owners.

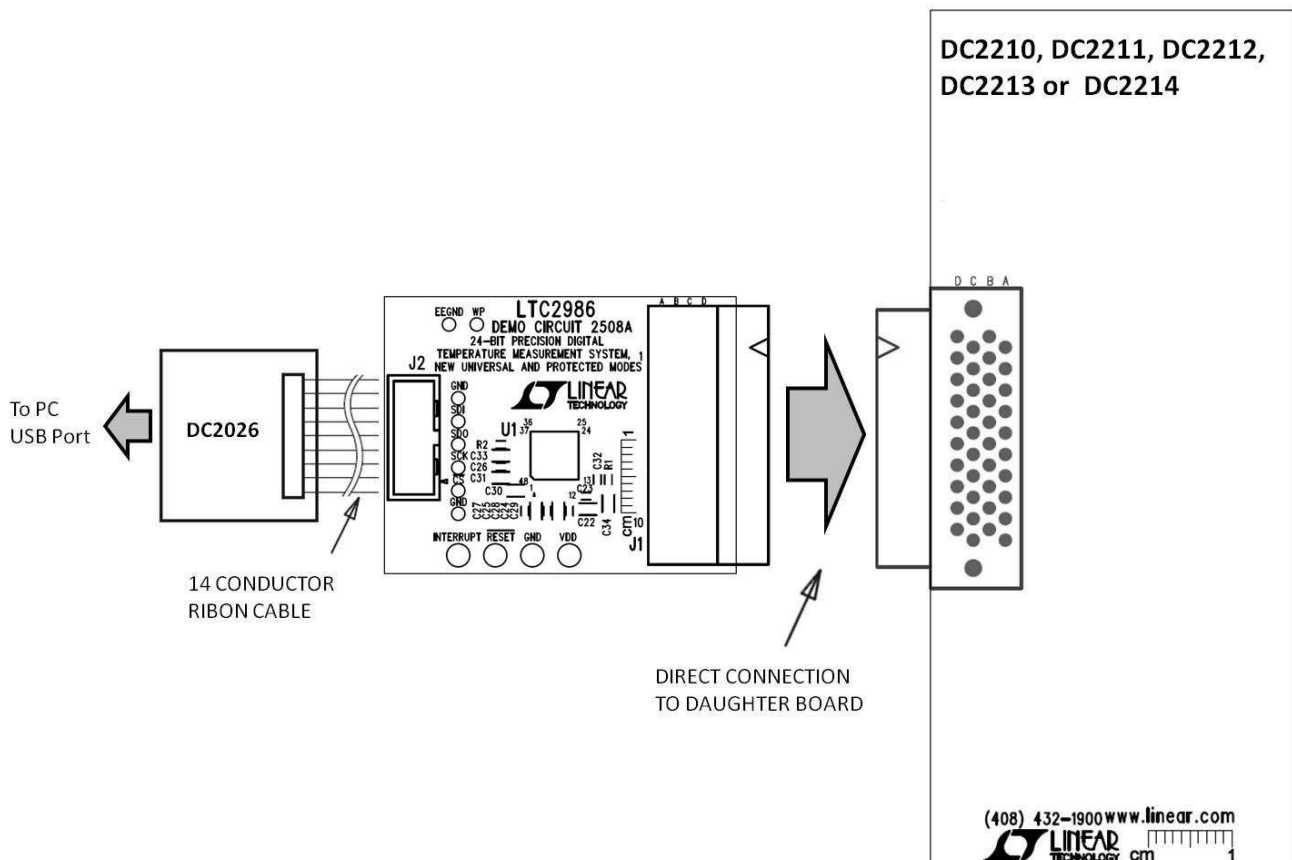

Figure 1. DC2508 Temperature Measurement Demonstration Board

## QUICK START PROCEDURE

Connect one of the five sensor daughter boards (DC2210, DC2211, DC2212, DC2213 or DC2214) to the DC2508 demo board. Connect the DC2508 to a DC2026 using the supplied 14-conductor ribbon cable. Connect the DC2026 to the PC using a standard USB A/B cable. Run the QuikEval software which the latest version can be downloaded from the Linear website at [www.linear.com/software](http://www.linear.com/software). The LTC2986 demo program will be loaded automatically. Refer to software manual LTC2986DSM for more detailed information.

The demo software helps program and run the LTC2986. It can configure the LTC2986, check and save the configuration, run the LTC2986, output the results into a file, and even create Linduino One ready C code based on the configuration. The demo software allows the user to configure the LTC2986 manually or automatically from data stored in the daughter board EEPROM. Please see [www.linear.com/LTC2986software](http://www.linear.com/LTC2986software) for the demo software manual. It includes a short tutorial for getting started. Figure 2 shows a screenshot of the demo software at start-up.

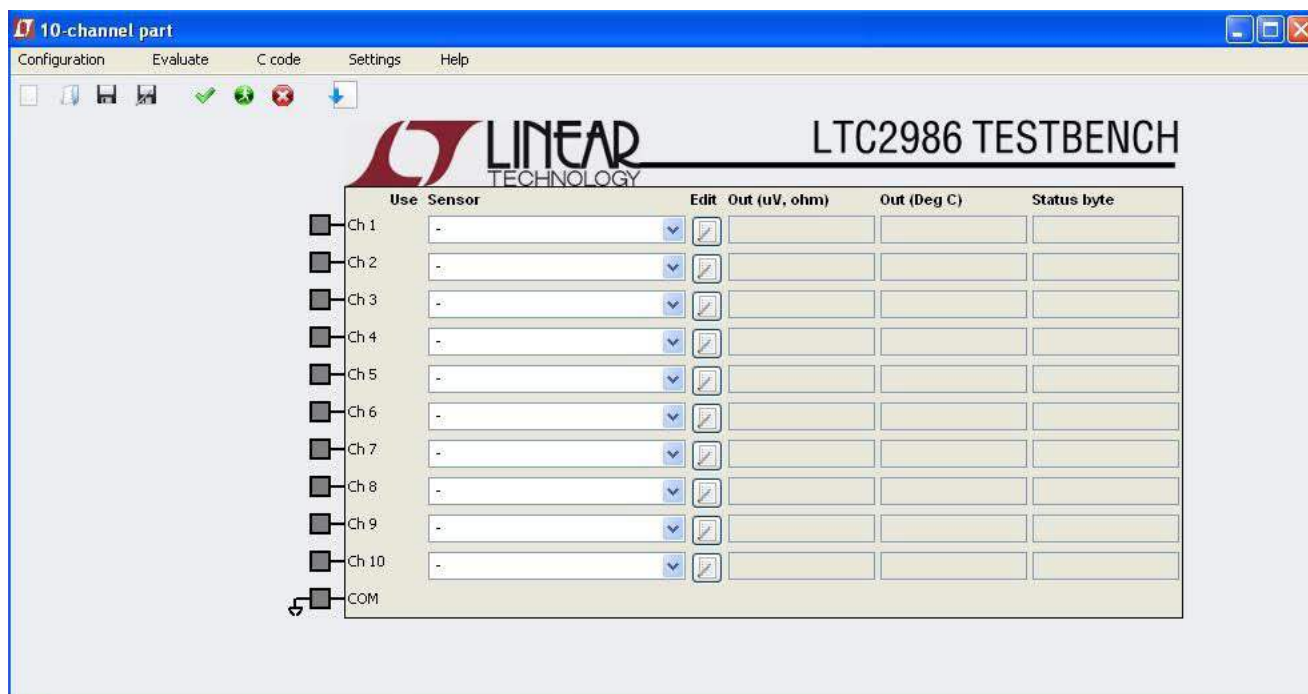

Figure 2. LTC2986 Demo Software

## HARDWARE SETUP

### DC2210 EXPERIMENTER BOARD (INCLUDED IN DC2531 KIT)

The DC2210 experimenter board (see Figure 3) brings all LTC2986 channels plus the COM connection out to a proto area and a 24-position terminal block. The user may

connect any of the supported sensors and sense resistors to any of the LTC2986 inputs in this area. Figure 4 shows the connection schematic of the DC2210 Experimenter board. Please note that only CH1 to CH10 are valid on the DC2210 when used in conjunction with the DC2508.

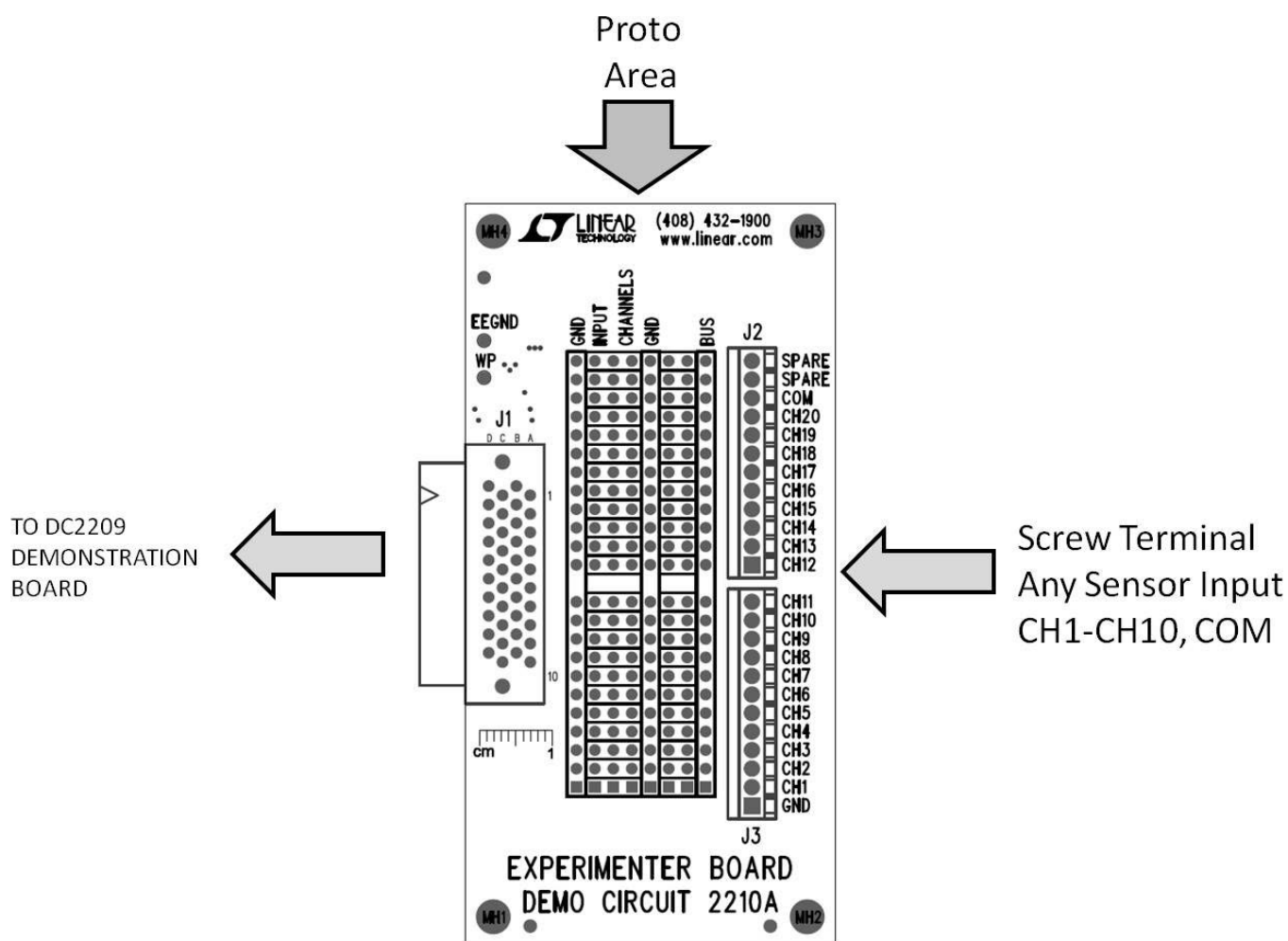

Figure 3. DC2210 Experimenter Board

**HARDWARE SETUP**

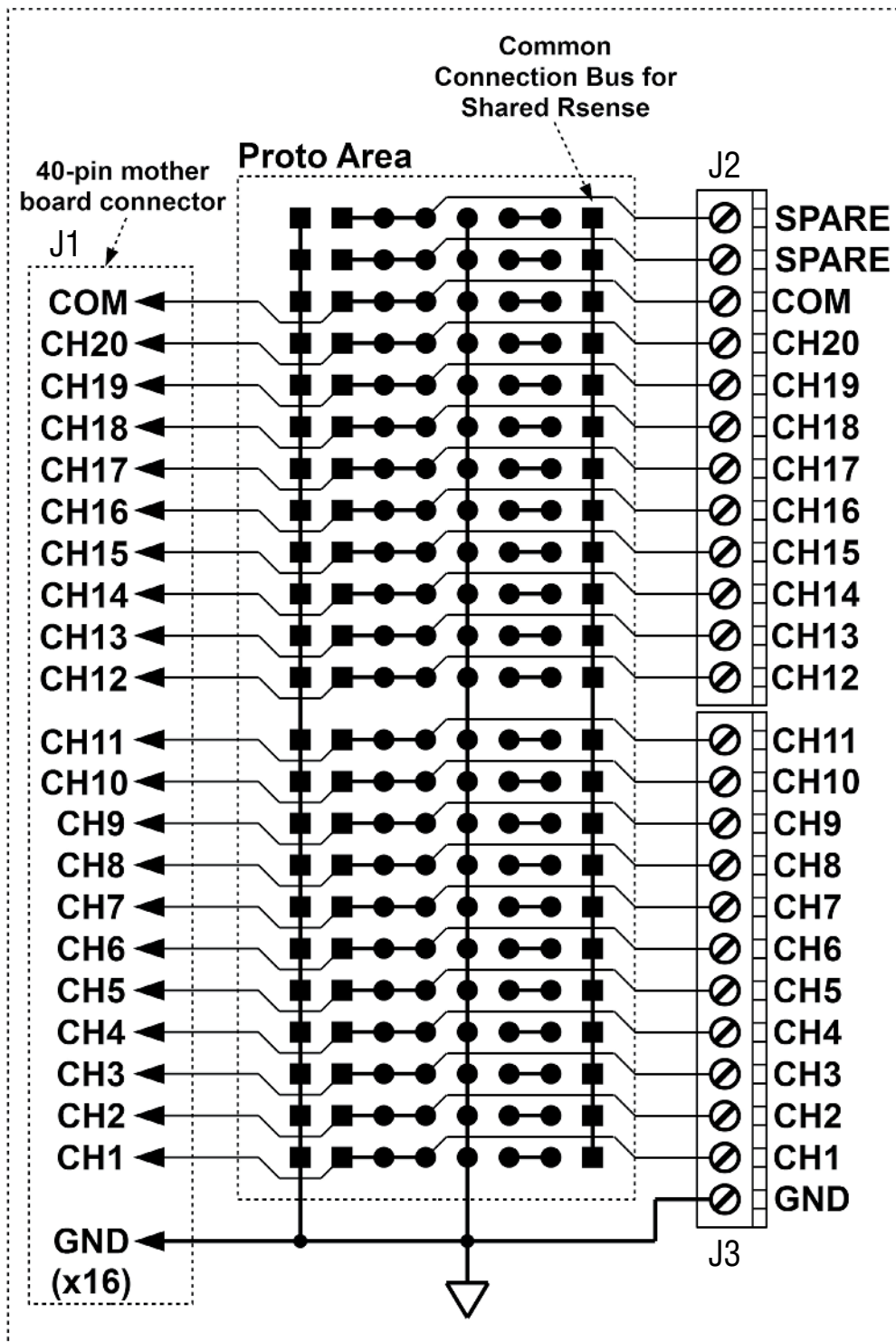

Figure 4. DC2210 Experimenter Board Schematic

## HARDWARE SETUP

### DC2211 UNIVERSAL TEMPERATURE MEASUREMENT BOARD

The universal temperature measurement board (see Figure 5) allows the user to connect any of the LTC2986 supported sensors to the DC2508 demo board.

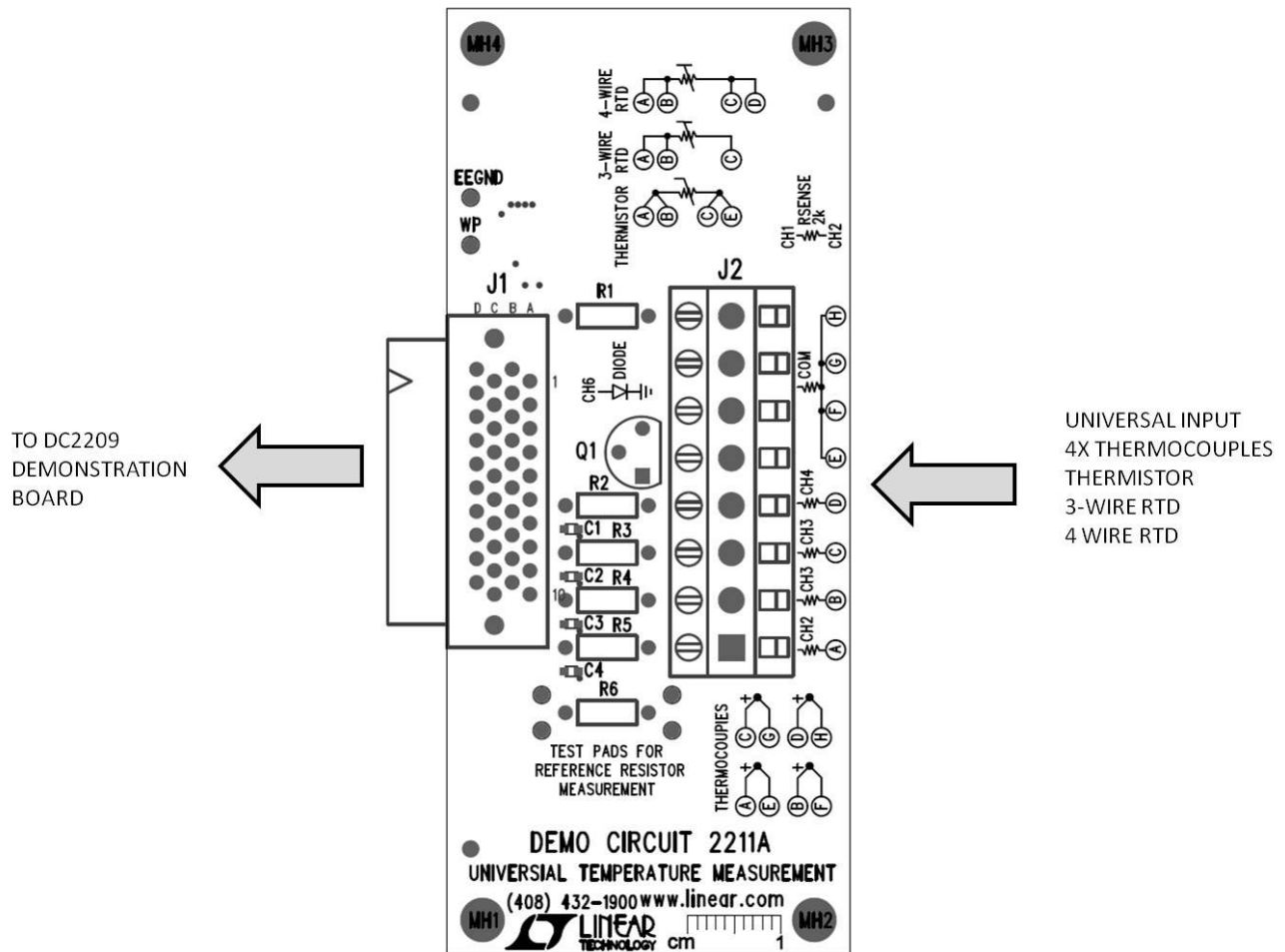

Figure 5. DC2211 Universal Temperature Measurement Board

## HARDWARE SETUP

The universal temperature measurement board has a built-in sense resistor for RTD applications as well as a cold junction sensor diode for thermocouple applications (see Figure 6 for the DC2211 schematic diagram). The sense resistor is a  $2k\Omega \pm 0.1\%$   $10\text{ppm}/^\circ\text{C}$  sense resistor on channels 1 and 2 which may be used with any of the supported RTD sensor types. The precise value of this sense resistor is stored in an on-board EEPROM. The LTC2986 demo software can read this EEPROM and use to configure the sense resistor value in the LTC2986's configuration memory.

The external interface on the universal temperature measurement board is an 8-position screw-terminal block with the following pinout.

**Table 1. DC2211 Terminal Connector Pinout**

Position A	LTC2986 CH2 as well as the low side of the on-board 2k sense resistor
Position B	LTC2986 CH3
Position C	LTC2986 CH4
Position D	LTC2986 CH5
Position E	Common/Ground Connection
Position F	Common/Ground Connection
Position G	Common/Ground Connection
Position H	Common/Ground Connection

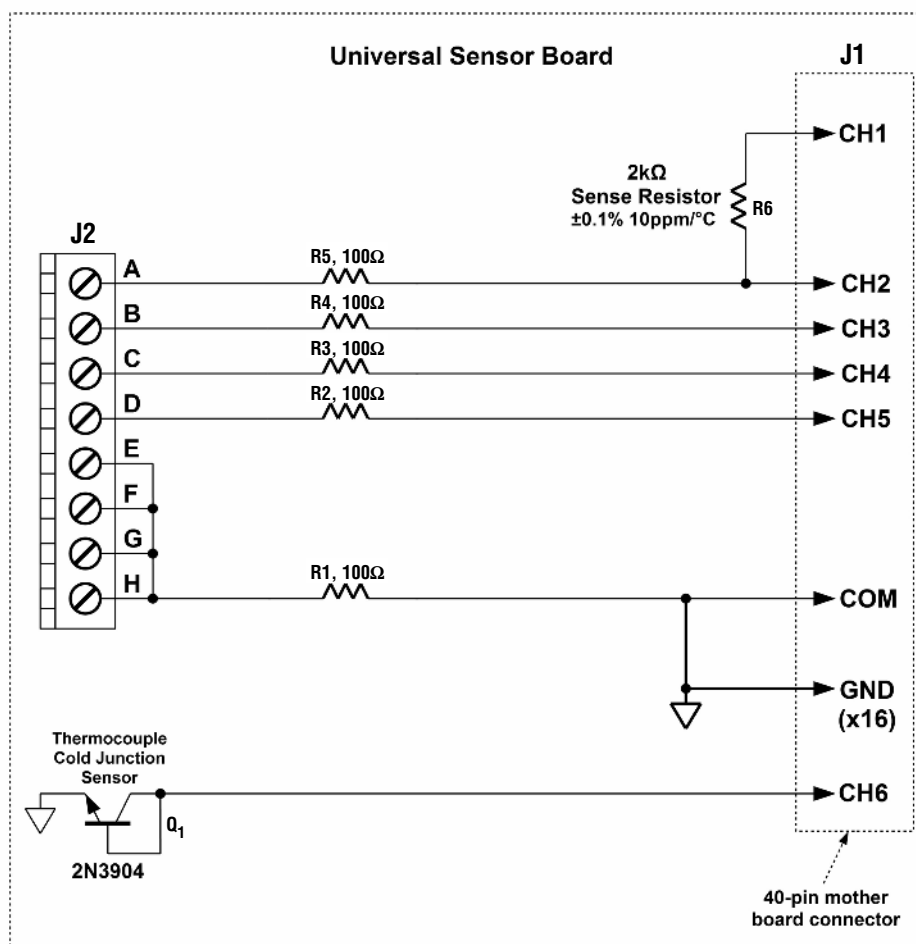

Figure 6. DC2211 Universal Temperature Measurement Board Schematic

## HARDWARE SETUP

### UNIVERSAL TEMPERATURE MEASUREMENT DAUGHTER BOARD EXAMPLES

- Four thermocouples connected to positions A-D with the negative connections tied to positions E-H using the on-board diode as cold junction sensor (see Figure 7a for the schematic and Figure 8a for the corresponding software configuration).

- A 4-wire RTD connected to positions A-D using the on-board sense resistor as the ratiometric reference (see Figure 7b for the schematic and Figure 8b for the corresponding software configuration).

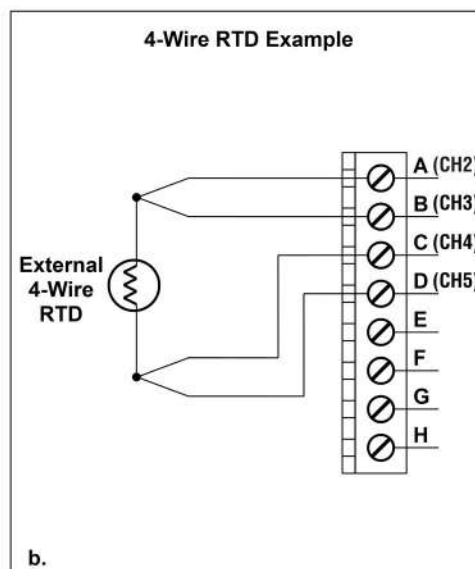
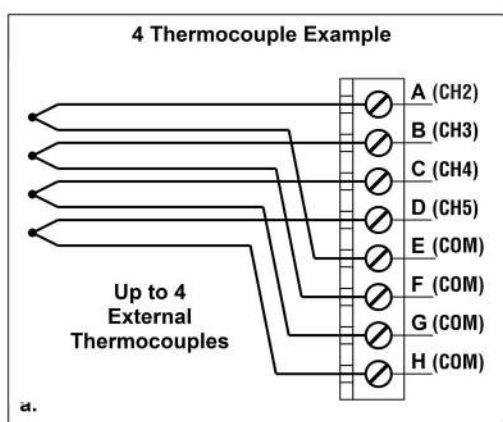

Figure 7. Universal Temperature Measurement Board Examples

## HARDWARE SETUP

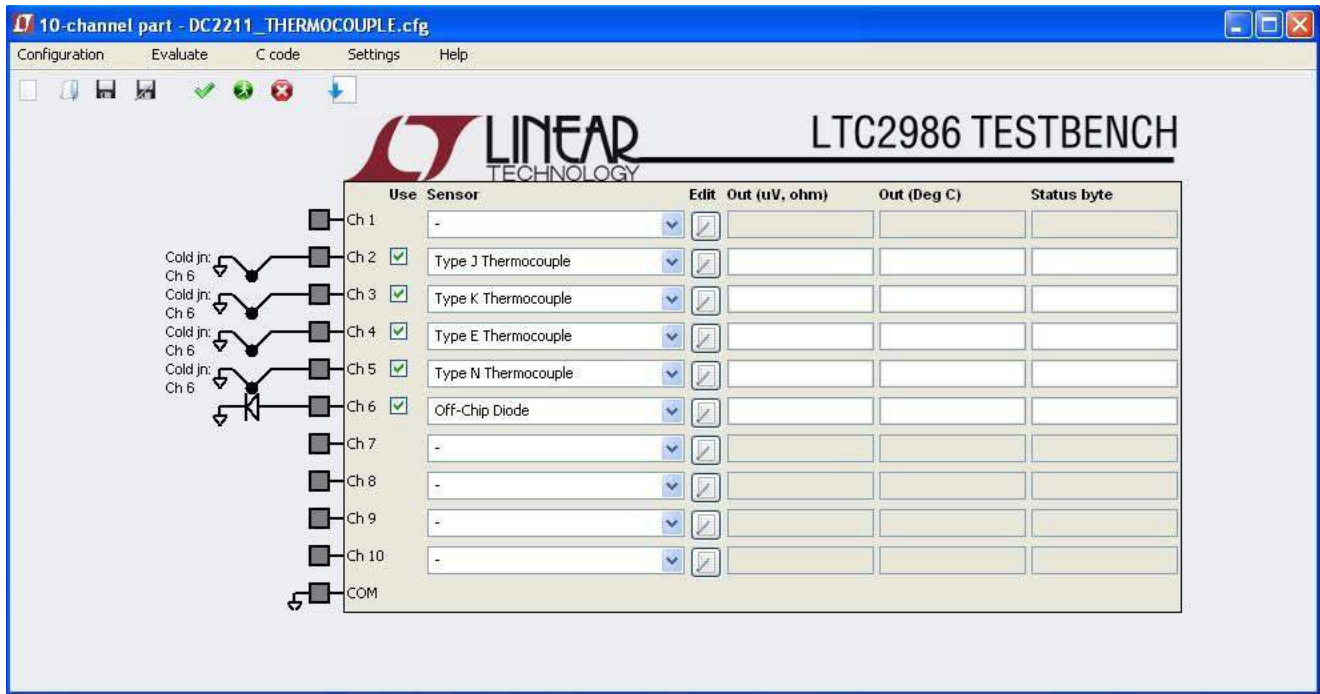

Figure 8a. DC2211 Four Thermocouple Software Configuration



# HARDWARE SETUP

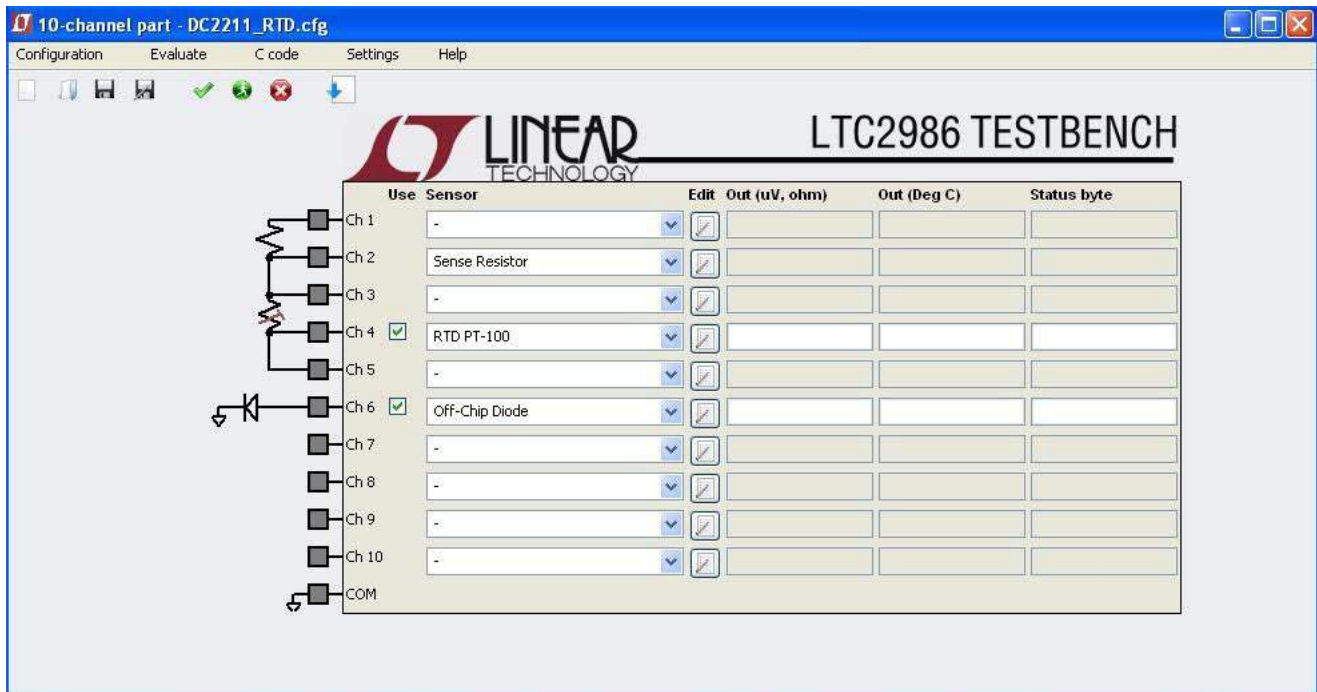

Figure 8b. DC2211 4-Wire RTD Software Configuration

## HARDWARE SETUP

### DC2212 THERMOCOUPLE DAUGHTER BOARD

The thermocouple board (see Figure 9) demonstrates the flexibility, accuracy, and low noise features of the LTC2986 thermocouple modes.

If the user wishes to connect external sensors to the thermocouple board, two universal-type thermocouple jacks (J2 and J3) are provided (see schematic diagram Figure 10 and corresponding software configuration Figure 11). The user may connect any of the LTC2986 supported thermocouples (B, E, J, K, N, R, S, or T) as well as custom thermocouples through these jacks.

To demonstrate the flexibility of the LTC2986, the thermocouple board includes cold junction diodes (Q1 and Q2) embedded in each thermocouple socket. Alternatively, a 4-wire PT100 RTD (R5) can be used as the cold junction sensor for either or both thermocouples.

To demonstrate the low system noise and offset of the LTC2986, the thermocouple board provides a short to ground on channel 5.

To demonstrate the accuracy of the LTC2986, the thermocouple board allows the user to connect a thermocouple calibrator or an external voltage source to CH10 of the LTC2986 through a pair of banana jacks (J4 and J5).

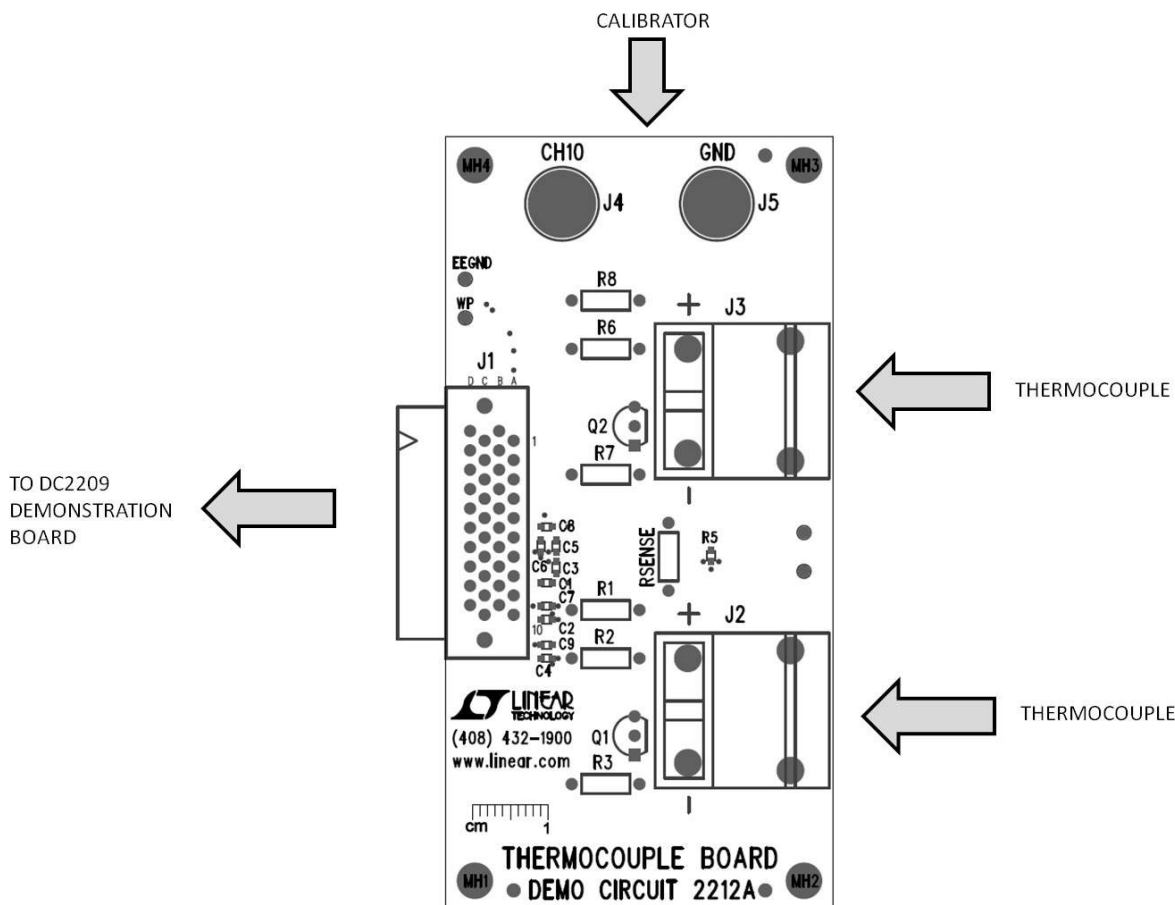

Figure 9. DC2212 Thermocouple Daughter Board

**HARDWARE SETUP**

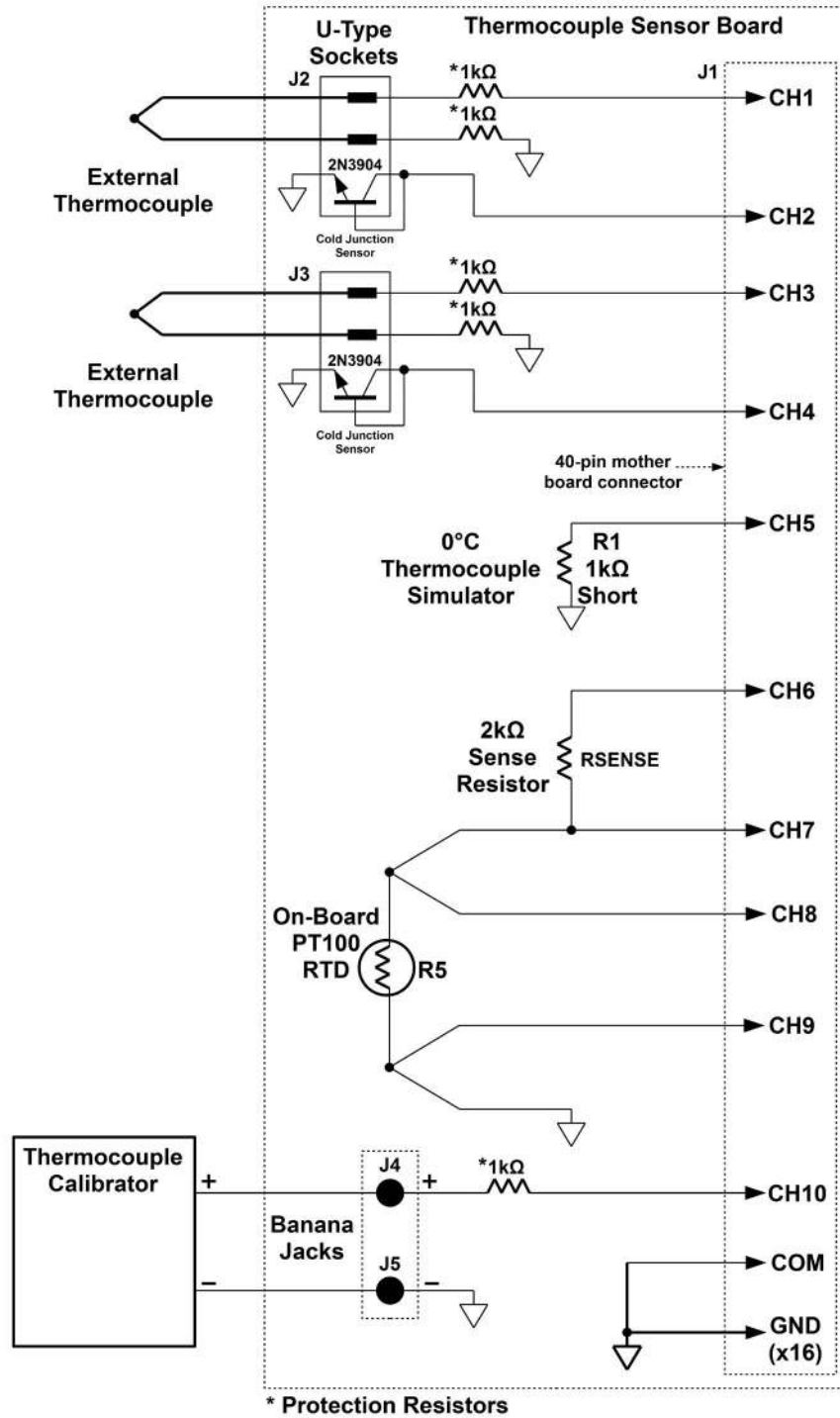

Figure 10. DC2212 Thermocouple Board Schematic

## HARDWARE SETUP

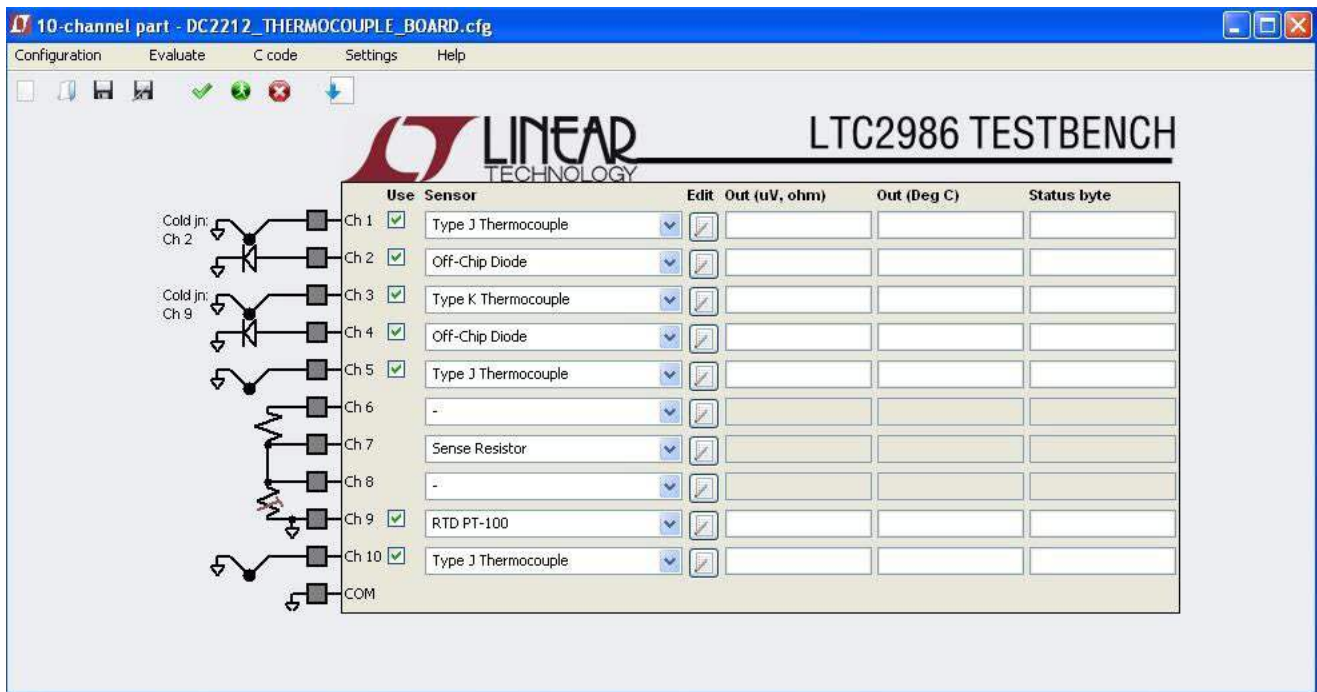

Figure 11. DC2212 Software Configuration

## HARDWARE SETUP

### DC2213 DEDICATED RTD BOARD

The DC2213 dedicated RTD board (see Figure 12) demonstrates the flexibility, accuracy, and low noise features of the LTC2986 RTD sensor modes. The DC2213 provides several circuits demonstrating the features of the LTC2986.

The DC2213 (see schematic diagram Figure 13 and corresponding software configuration Figure 14) provides a  $2k\Omega \pm 0.1\%$   $10\text{ppm}/^\circ\text{C}$  sense resistor on channels 2 and 3 which may be used with any of the RTD sensor circuits on this board. An additional Kelvin connection is also provided to this sense resistor on channel 1. The precise

measured value of this sense resistor is stored in an on-board EEPROM which the LTC2986 demo software can read and use to configure the sense resistor value.

To demonstrate the low system noise of the LTC2986, the dedicated RTD board provides a  $0^\circ\text{C}$  PT100 simulator ( $100\Omega \pm 0.01\%$   $10\text{ppm}/^\circ\text{C}$ ) on channels 3 to 6 configured as a 4-wire sensor. In addition to this the user may use this circuit to demonstrate how the rotated mode eliminates measurement error introduced by parasitic thermocouples. To facilitate this measurement, the DC2213 provides an external thermocouple interface which acts as a parasitic thermocouple.

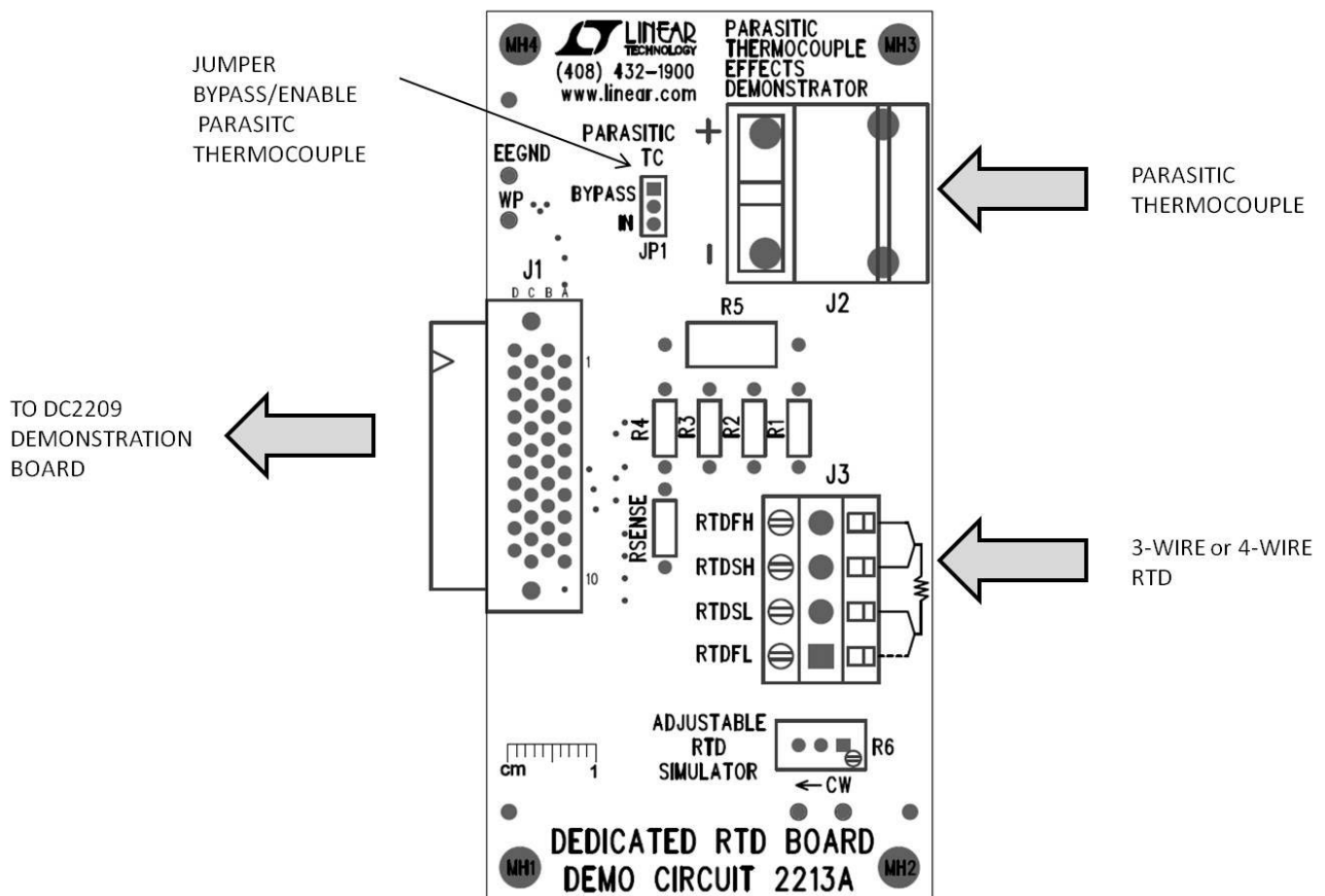

Figure 12. DC2213 Dedicated RTD Board

## HARDWARE SETUP

To see the effects of parasitic thermocouples on non-rotated measurement modes, first measure the on-board 0°C PT100 simulator in a non-rotated configuration and see the measurement error as the thermocouple's temperature changes. To see the benefit of the rotated measurement mode, switch from the no rotation/sharing to the rotation/sharing configuration and see the errors introduced by the parasitic thermocouple minimized.

In addition to the fixed value RTD simulator, there is also a variable resistor RTD simulator. This circuit can be used to demonstrate the range of the various LTC2986 RTD sensor modes as well as demonstrate the fault detection

capabilities of the LTC2986. Please note that the variable resistor feature of the DC2213 requires channel 11 and will not work with the DC2508.

If the user wishes to connect an external RTD to the sensor board, a 4-position terminal block is provided. The user may connect any of the LTC2986 supported RTDs as well as custom RTDs to the DC2508 demo board through this interface. The interface may be configured for 3 or 4 wire sensors. To demonstrate the accuracy of the LTC2986, the user may also connect an RTD calibrator or precision resistors to this interface.

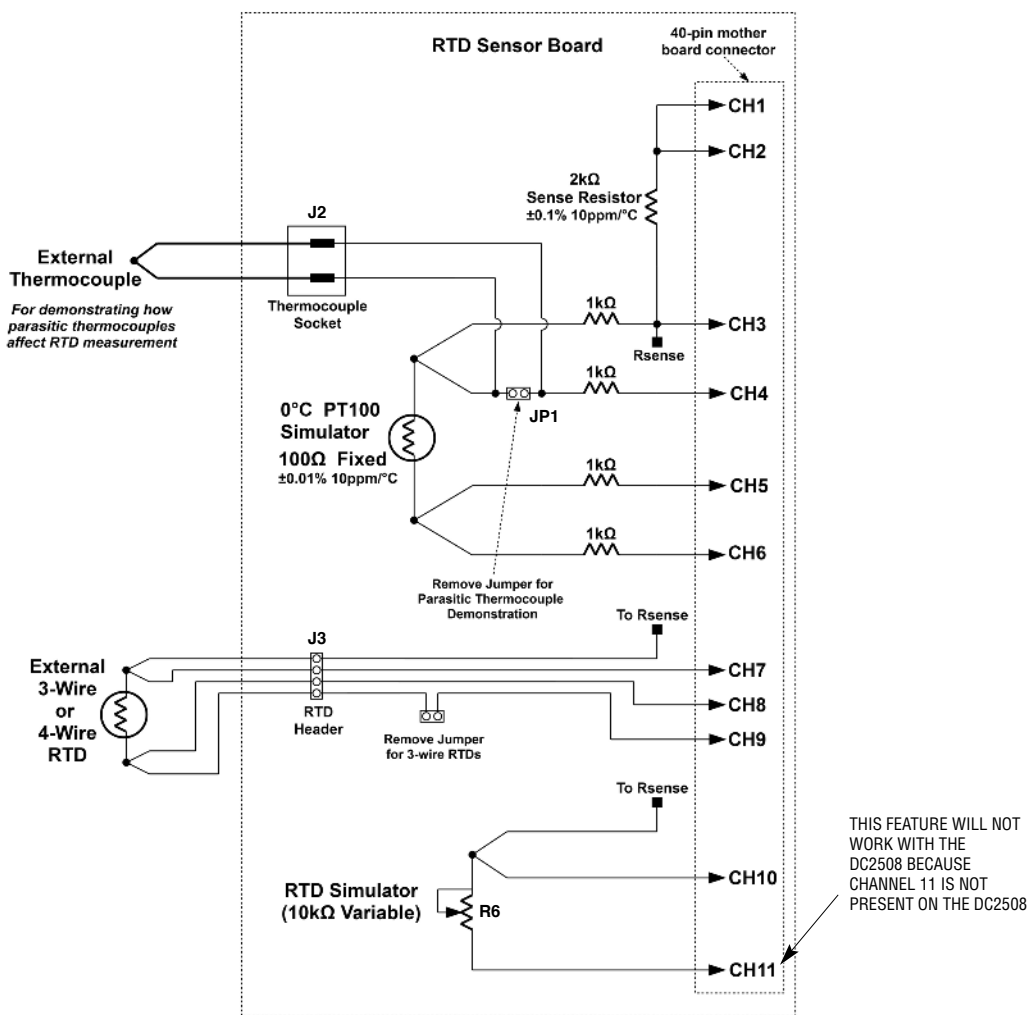

Figure 13. DC2213 Dedicated RTD Board Schematic

# HARDWARE SETUP

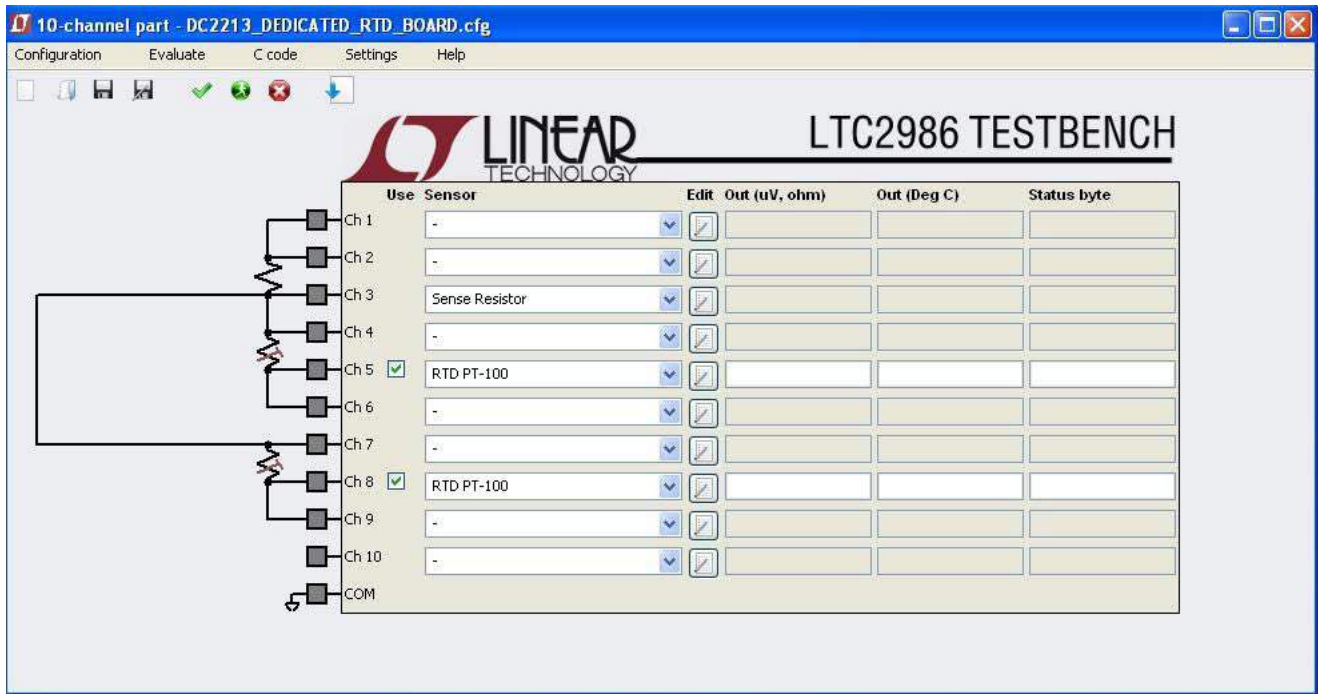

Figure 14. DC2213 Software Configuration

## HARDWARE SETUP

### DC2214 DEDICATED THERMISTOR BOARD

The DC2214 dedicated thermistor board includes several circuits (see Figure 15) to demonstrate the flexibility, accuracy, and low noise features of the LTC2986 thermistor sensor modes.

The DC2214 provides a  $10\text{k}\Omega \pm 0.1\%$   $15\text{ppm}/^\circ\text{C}$  sense resistor on channels 1 and 2 which is shared with all of the thermistor sensor circuits on this board (see schematic diagram Figure 16 and corresponding software configuration Figure 17). The measured value of this sense resistor is stored in an on-board EEPROM which the LTC2986 demo software can read and use to configure the sense resistor value.

To demonstrate the low system noise of the LTC2986 the dedicated thermistor board provides a  $25^\circ\text{C}$   $10\text{k}$  thermistor simulator ( $10\text{k}\Omega \pm 0.1\%$   $15\text{ppm}/^\circ\text{C}$ ) on channels 2-4 configured as a differential sensor. In addition to this the user may use this circuit to demonstrate how the rotated mode eliminates measurement error introduced by parasitic thermocouples. To facilitate this demonstration the DC2214 provides an external thermocouple interface which acts as a parasitic thermocouple.

To see the effects of parasitic thermocouples on non-rotated measurement modes, first measure the on-board  $25^\circ\text{C}$   $10\text{k}$  thermistor simulator in a no-rotation/sharing configuration and see the measurement error as the

thermocouple's temperature changes. To see the benefit of the rotated measurement mode, switch to the rotation/sharing configuration and see the errors introduced by the parasitic thermocouple disappear (the effects are more significant with lower excitation current).

The DC2214 also includes a  $499\text{k}\Omega$  ( $0.1\%$   $15\text{ppm}/^\circ\text{C}$ ) thermistor simulator on channels 9 and 10. Ideally, this resistor simulates  $-30.59^\circ\text{C}$  for a 44008 ( $30\text{k}$ ) thermistor and  $-51.94^\circ\text{C}$  for a 44006 ( $10\text{k}$ ) thermistor. Note, the  $10\text{k}$  thermistor reports the temperature, but also indicates a soft fault since the temperature is below the thermistor's specified minimum temperature.

In addition to the fixed value thermistor simulators, there is a variable resistor thermistor simulator as well. This circuit can be used to demonstrate the range of the various LTC2986 thermistor sensor modes as well as demonstrate the fault detection capabilities of the LTC2986.

If the user wishes to connect an external thermistor to the daughter board, a 2-position terminal block is provided. The user may connect any of the LTC2986 supported thermistors as well as custom thermistors to the DC2508 demo board through this interface. To demonstrate the accuracy of the LTC2986, the user may connect external resistance standards to this interface.



**HARDWARE SETUP**

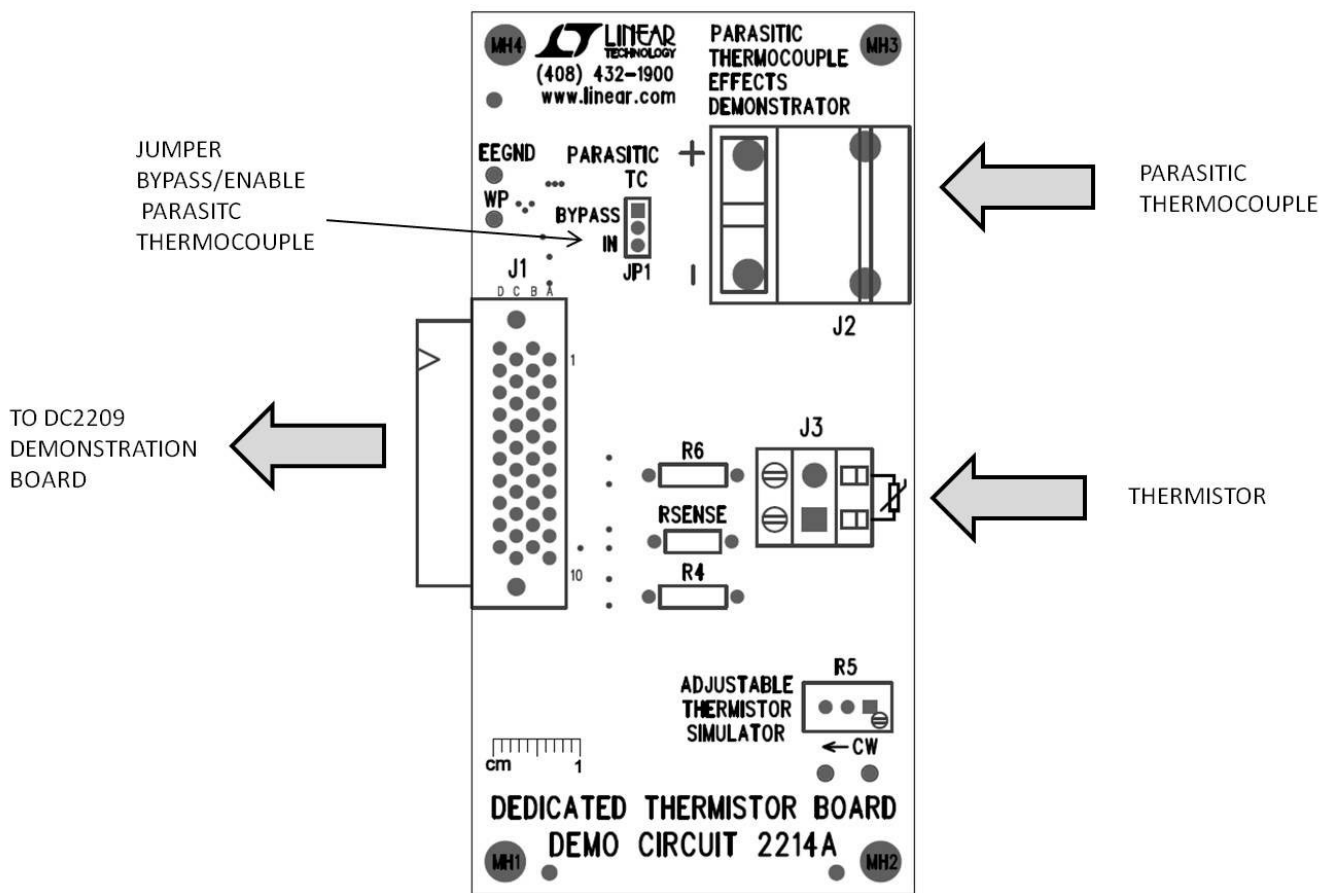

Figure 15. DC2214 Thermistor Daughter Board

## HARDWARE SETUP

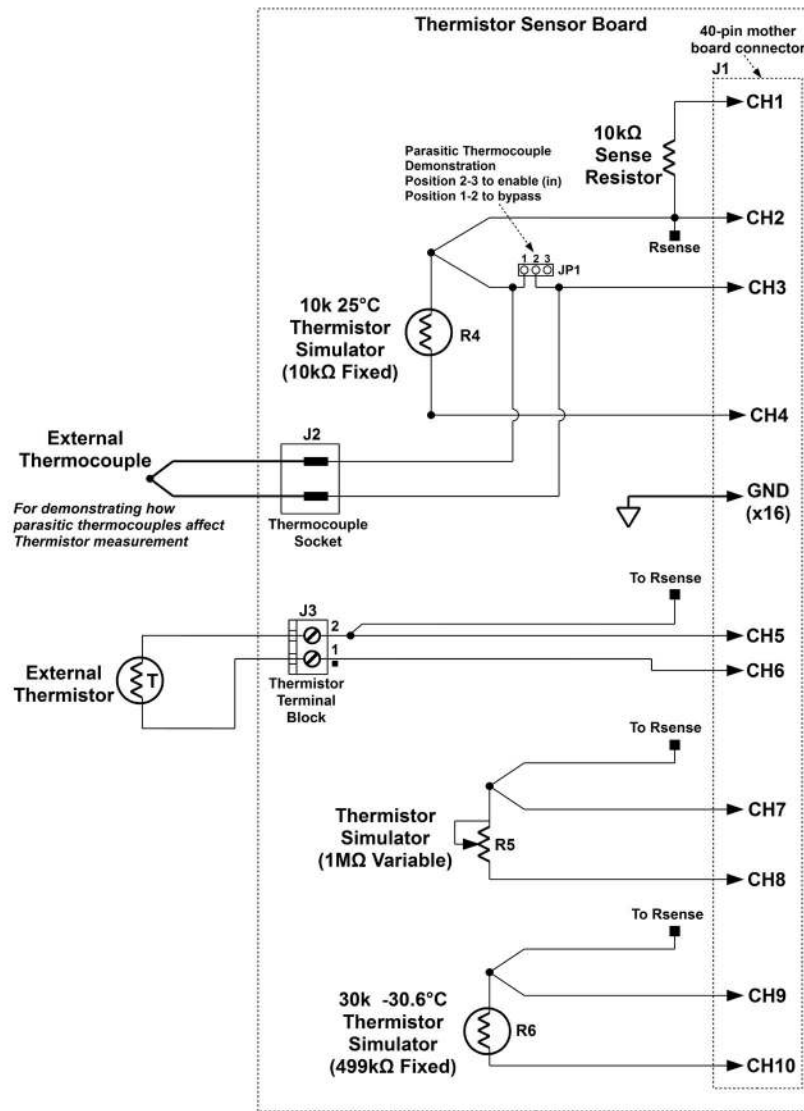

Figure 16. DC2214 Dedicated Thermistor Board Schematic

# HARDWARE SETUP

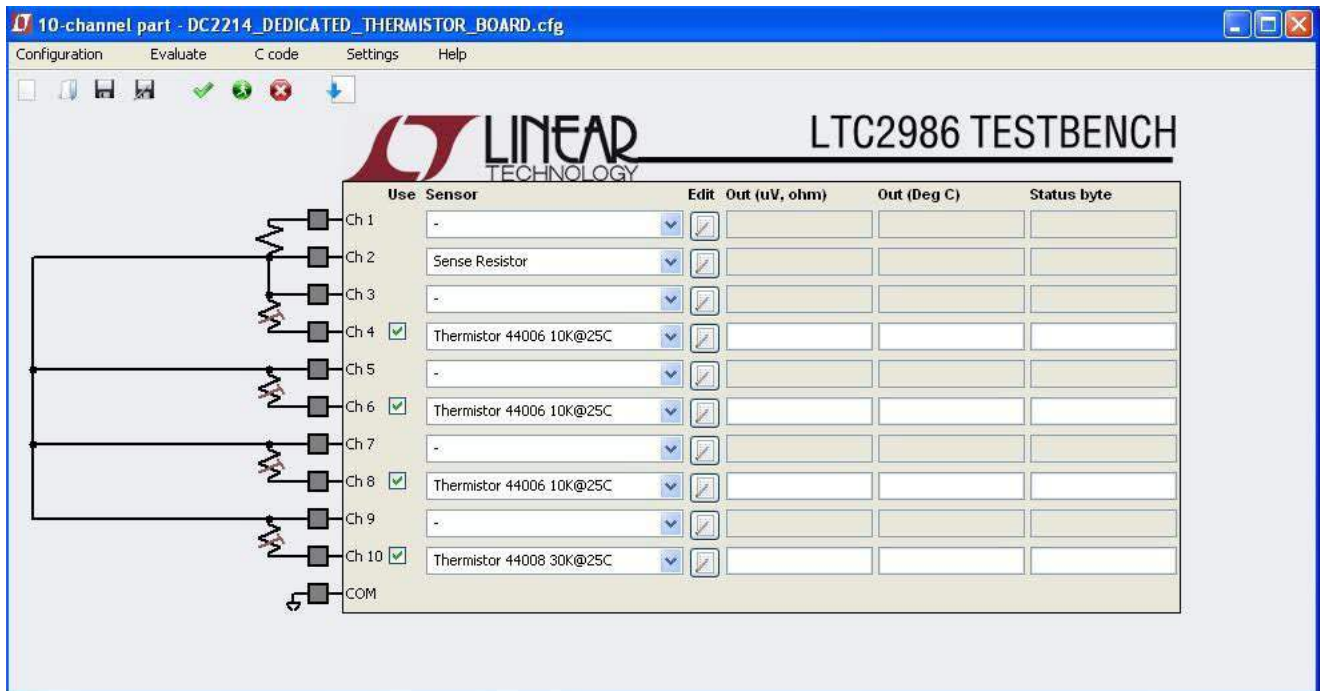

Figure 17. DC2214 Software Configuration

# DEMO MANUAL DC2531

## PARTS LIST

ITEM	QTY	REFERENCE	PART DESCRIPTION	MANUFACTURER/PART NUMBER
<b>DC2531 Required Circuit Components</b>				
1	21	C1 TO C11	CAP., NP0, 100pF 100V, 5%, 0603	MURATA, GRM1885C2A101JA01D
2	7	C22, C24, C25, C30, C31, C33, C34	CAP., X7R, 10µF 10V, 10%, 0805	MURATA, GRM21BR71A106KE51L
3	7	C23, C26, C27, C28, C29, C32, C35	CAP., X7R, 0.1µF 25V, 10%, 0603	MURATA, GRM188R71E104KA01D
4	4	E1, E2, E3, E4	TURRET, TESTPOINT 0.064"	MILL-MAX, 2308-2-00-80-00-00-07-0
5	1	J1	CONN., 40P, CON-HIROSE-FX2-40P-1.27DS	HIROSE, FX2-40P-1.27DS
6	1	J2	CONN., HEADER 14POS 2MM VERT GOLD	MOLEX, 87831-1420
7	1	R1	RES., CHIP, 1Ω, 1/10W, 5% 0603	VISHAY, CRCW06031R00FJEA
8	1	R2	RES., CHIP, 100k, 1/10W, 1% 0603	VISHAY, CRCW0603100KFKEA
9	3	R3, R4, R5	RES., CHIP, 4.99k, 1/10W, 1% 0603	VISHAY, CRCW06034K99FKEA
10	1	U1	I.C., LTC2986CLX, LQFP48LX-7X7	LINEAR TECH., LTC2986CLX
11	1	U2	I.C., 24LC025-I/ST, TSSOP8	MICROCHIP, 24LC025-I/ST
12	2	MH1, MH2	STANDOFF, NYLON, 0.25", 1/4"	KEYSTONE, 8831 (SNAP ON)
<b>DC2210 Required Circuit Components</b>				
1	1	C1	CAP., X7R, 0.1µF 25V, 10%, 0603	MURATA, GRM188R71E104KA01D
2	1	J1	CONN., 40P, CON-HIROSE-FX2-40S-DAUGHTER	HIROSE, FX2-40S-1.27DS(71)
3	2	J2,J3	CONN., TERM BLOCK 2.54MM 12POS	PHOENIX, 1725753
4	0	R1,R2	RES., 0603	OPT
5	1	R3	RES., CHIP, 4.99k, 1/10W, 1% 0603	PANASONIC, ERJ-3EKF4991V
6	1	U1	I.C., EEPROM 2KBIT 400KHZ 8TSSOP	MICROCHIP, 24LC025-I/ST
7	4	MH1-MH4	STANDOFF, NYLON, 0.25", 1/4"	KEYSTONE, 8831 (SNAP ON)

**SCHEMATIC DIAGRAM**

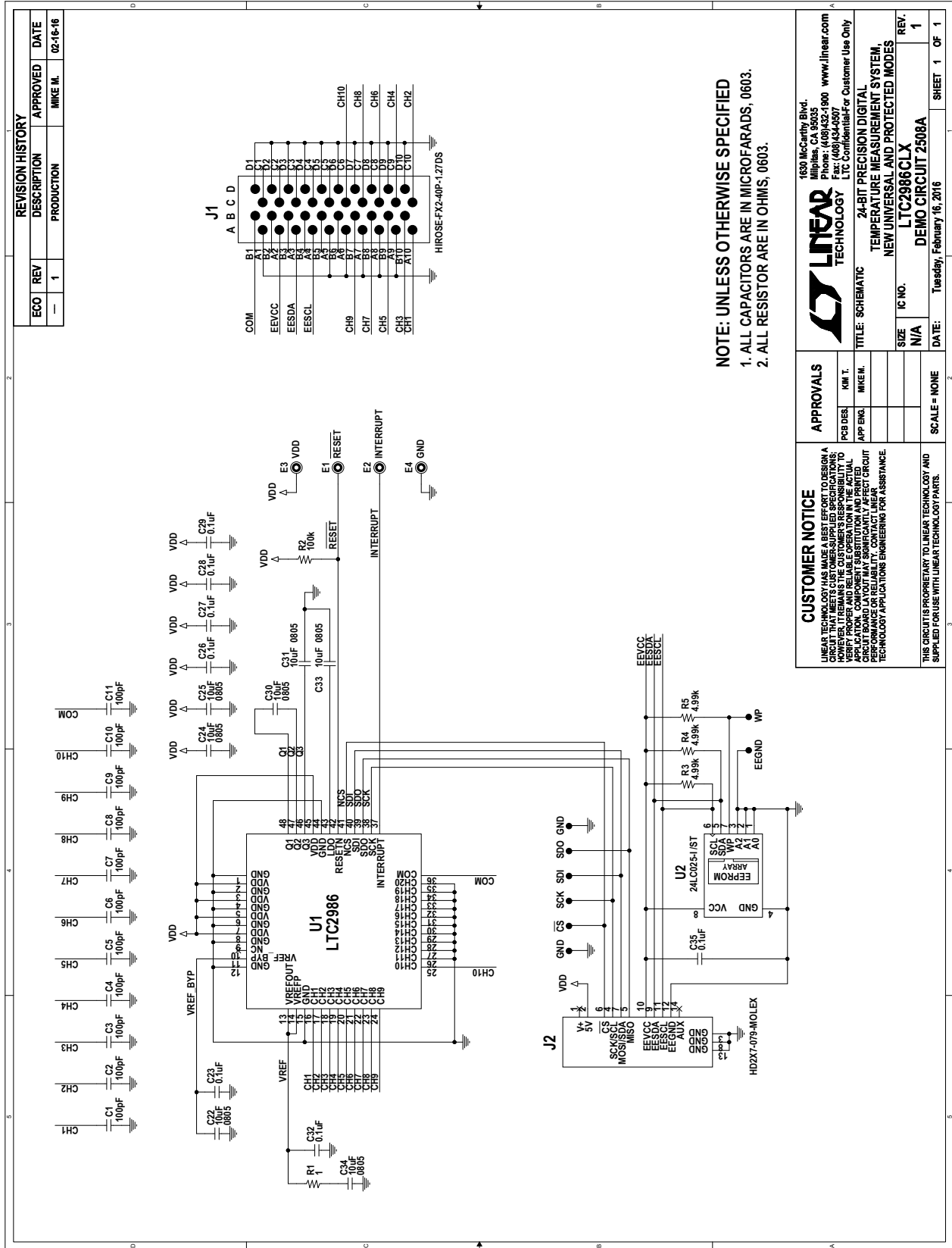

# DEMO MANUAL DC2531

---

## DEMONSTRATION BOARD IMPORTANT NOTICE

Linear Technology Corporation (LTC) provides the enclosed product(s) under the following **AS IS** conditions:

This demonstration board (DEMO BOARD) kit being sold or provided by Linear Technology is intended for use for **ENGINEERING DEVELOPMENT OR EVALUATION PURPOSES ONLY** and is not provided by LTC for commercial use. As such, the DEMO BOARD herein may not be complete in terms of required design-, marketing-, and/or manufacturing-related protective considerations, including but not limited to product safety measures typically found in finished commercial goods. As a prototype, this product does not fall within the scope of the European Union directive on electromagnetic compatibility and therefore may or may not meet the technical requirements of the directive, or other regulations.

If this evaluation kit does not meet the specifications recited in the DEMO BOARD manual the kit may be returned within 30 days from the date of delivery for a full refund. **THE FOREGOING WARRANTY IS THE EXCLUSIVE WARRANTY MADE BY THE SELLER TO BUYER AND IS IN LIEU OF ALL OTHER WARRANTIES, EXPRESSED, IMPLIED, OR STATUTORY, INCLUDING ANY WARRANTY OF MERCHANTABILITY OR FITNESS FOR ANY PARTICULAR PURPOSE. EXCEPT TO THE EXTENT OF THIS INDEMNITY, NEITHER PARTY SHALL BE LIABLE TO THE OTHER FOR ANY INDIRECT, SPECIAL, INCIDENTAL, OR CONSEQUENTIAL DAMAGES.**

The user assumes all responsibility and liability for proper and safe handling of the goods. Further, the user releases LTC from all claims arising from the handling or use of the goods. Due to the open construction of the product, it is the user's responsibility to take any and all appropriate precautions with regard to electrostatic discharge. Also be aware that the products herein may not be regulatory compliant or agency certified (FCC, UL, CE, etc.).

No License is granted under any patent right or other intellectual property whatsoever. **LTC assumes no liability for applications assistance, customer product design, software performance, or infringement of patents or any other intellectual property rights of any kind.**

LTC currently services a variety of customers for products around the world, and therefore this transaction **is not exclusive**.

**Please read the DEMO BOARD manual prior to handling the product.** Persons handling this product must have electronics training and observe good laboratory practice standards. **Common sense is encouraged.**

This notice contains important safety information about temperatures and voltages. For further safety concerns, please contact a LTC application engineer.

Mailing Address:

Linear Technology  
1630 McCarthy Blvd.  
Milpitas, CA 95035

Copyright © 2004, Linear Technology Corporation