

PART NUMBER WITH CAP IN EMBOSSED TAPE	PLATING TYPE	CKT SIZE	A	B
87762-0021	1	44	42.00	43.90

**NOTES:**

- MATERIAL: HOUSING: NYLON 46, 30% G.F., UL94V-0, COLOR: BLACK  
PIN: COPPER ALLOY, SQ, 0.5mm
- PLATING FINISH:  
(1) 15μ INCHES MIN GOLD PLATE IN SELECTED AREA AND  
75μ INCHES MIN TIN ON SOLDER TAIL OVER  
50μ INCHES MIN NICKEL OVERALL.
- FOR PCB DETAIL, SEE PAGE 2
- PRODUCT SPECIFICATION: PS-87761-001
- RECOMMENDED PC BOARD THICKNESS IS 1.60±0.10mm
- COPLANARITY IS TO BE MEASURED BY RESTING THE SOLDER TAIL ON A GAUGE SURFACE
- CAP TO BE LOCATED AS CENTRAL OF PART AS POSSIBLE
- THE ABOVE 14CKTS SHOWN IS FOR ILLUSTRATION ONLY.
- PARTS TO BE PACKED IN EMBOSSED TAPE.

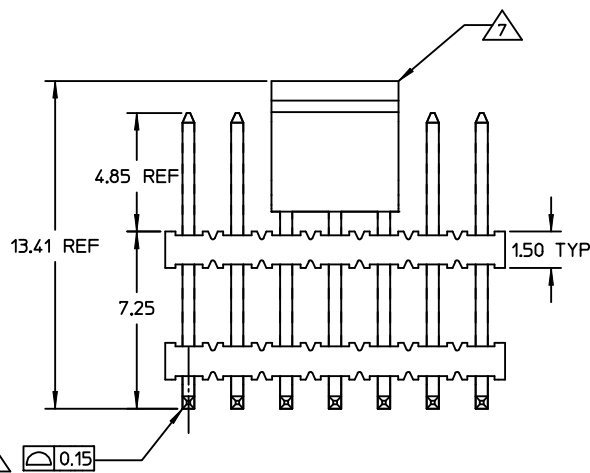
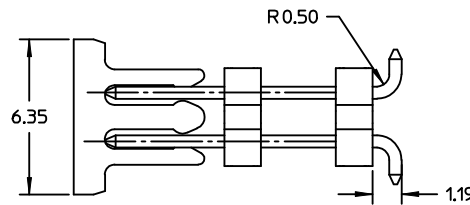
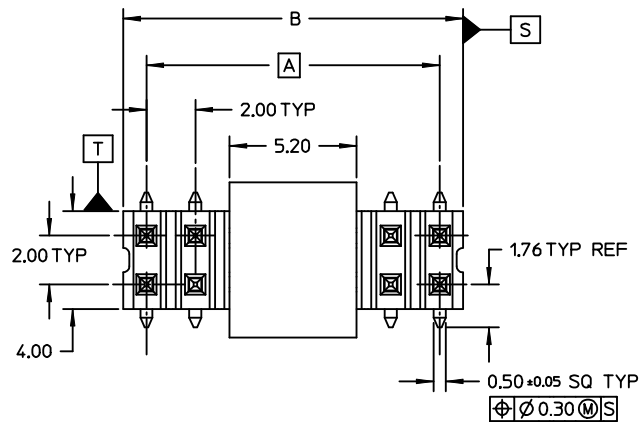

EC NO: S2004-0824 DRWN:KCHO 2004/06/22 CHKD:PTLIM 2004/06/22 APPR:SKTOH 2004/06/23	QUALITY SYMBOLS	GENERAL TOLERANCES (UNLESS SPECIFIED)	SCALE NTS	DESIGN UNITS METRIC	THIRD ANGLE PROJECTION	REVISE ON CAD ONLY
	▼ = 0 ∇ = 0	mm      INCH 4 PLACES ± --- ± --- 3 PLACES ± --- ± --- 2 PLACES ± 0.20 ± --- 1 PLACE ± --- ± ---	DIMENSION STYLE MM ONLY		TITLE	
			DRAWN BY DATE KCHO 2004/06/08		SALES DRAWING 2.00MM PITCH SMT HEADER DUAL ROW 44 CKTS	
	A	DESCRIPTION	ANGULAR ± 3°	CHECKED BY DATE PTLIM 2004/06/17	MATERIAL NO. DOCUMENT NO. SHEET NO.	
DRAFT WHERE APPLICABLE MUST REMAIN WITHIN DIMENSIONS		APPROVED BY DATE SLOW 2004/06/18	THIS DRAWING CONTAINS INFORMATION THAT IS PROPRIETARY TO MOLEX INCORPORATED AND SHOULD NOT BE USED WITHOUT WRITTEN PERMISSION			

CKT SIZE	C	D	E	F
44	34.20	44.20	68.40	72.00

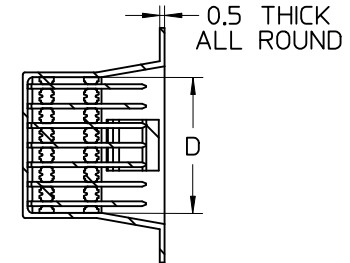
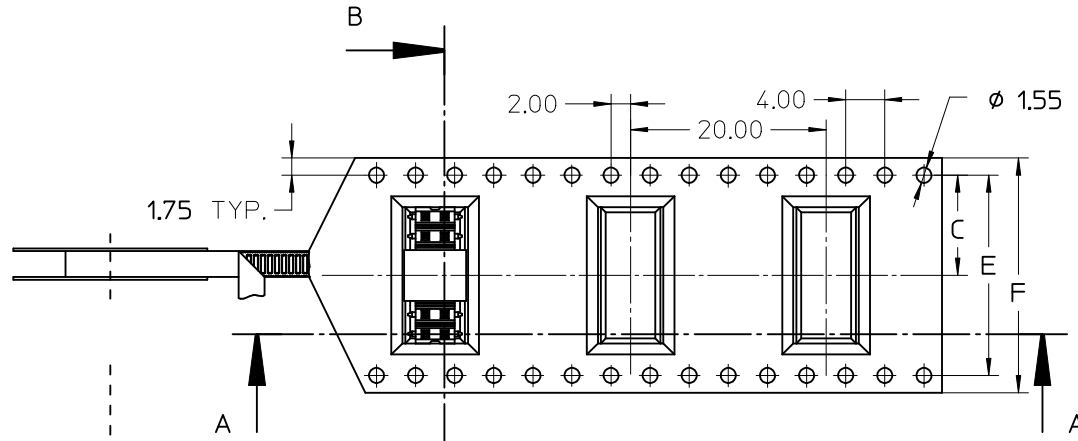

Section B-B

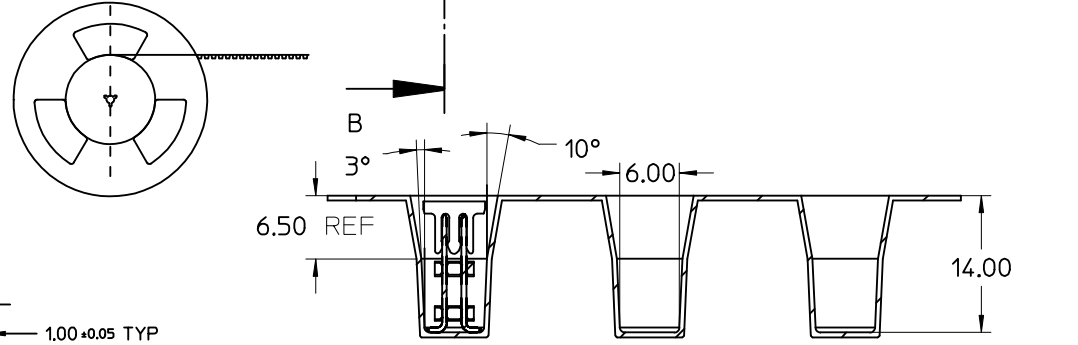

Section A-A

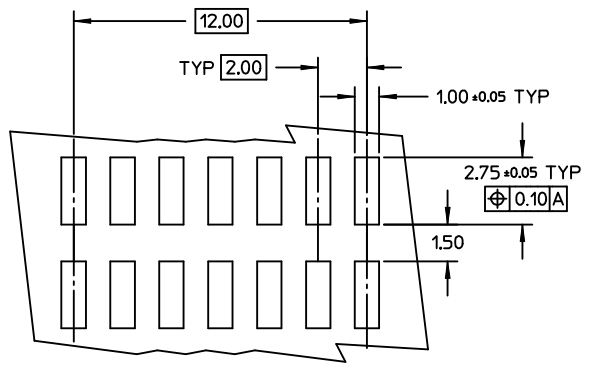

RECOMMENDED PCB PATTERN

EC NO: S2004-0824 DRWN: KCHO 2004/06/22 CHKD: PTLIM 2004/06/22 APPR: SKTOH 2004/06/23	QUALITY SYMBOLS ▽ -0 ◁ -0	GENERAL TOLERANCES (UNLESS SPECIFIED)		SCALE NTS	DESIGN UNITS METRIC	THIRD ANGLE PROJECTION	REVISE ON CAD ONLY		
		mm	INCH	DIMENSION STYLE MM ONLY					
		4 PLACES ± --- ± ---	3 PLACES ± --- ± ---	2 PLACES ± 0.20 ± ---	1 PLACE ± --- ± ---	DRAWN BY KCHO	DATE 2004/06/08	TITLE SALES DRAWING 2.00MM PITCH SMT HEADER DUAL ROW 44 CKTS	
		ANGULAR ± 3°				CHECKED BY PTLIM	DATE 2004/06/17	MOLEX INCORPORATED	
DRAFT WHERE APPLICABLE MUST REMAIN WITHIN DIMENSIONS				APPROVED BY SCLW	DATE 2004/06/18	MATERIAL NO. SEE TABLE SD-87762-048	DOCUMENT NO. SD-87762-048	SHEET NO. 2 OF 2	