

PART NUMBER	REV	FIRST USED
680579-1	C	354500-1
680579-2	B	565435-5

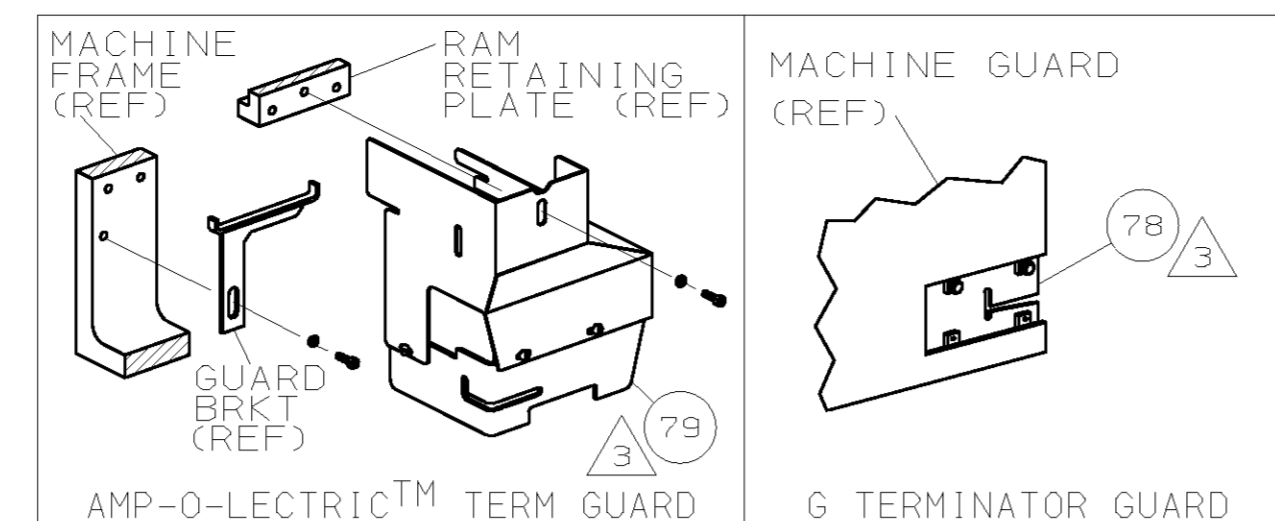

PAD LTR		CRIMP HEIGHT		WIRE SIZE (MAG)
A	.091 ±.002 [2.31 ±0.05mm]			11
B	.086 ±.002 [2.18 ±0.05mm]			12
C	.081 ±.002 [2.06 ±0.05mm]			13
D	NOT			USED
CRIMP		SIZE	TYPE	RANGE
WIRE		.180 [4.57mm]	F	13-11
INSUL		-	-	-

WIRE STRIP LENGTH	TERM APPL SPEC	FEED	APPL INSTRUCTION	SET UP GAGE	LAYOUT
.203-.234	114-2084	.903	408-8039	458638-1	L2034

QTY	REV	U/M	DWG SIZE	PART NO	DESCRIPTION	ITEM NO
2	2	-	C	6-354778-6	PIN, WIRE DISC (.2825)C	129
2	2	-	C	5-354778-6	PIN, WIRE DISC (.2775)B	127
2	2	-	C	4-354778-6	PIN, WIRE DISC (.2725)A	126
1	1	-	A	986950-1	WASHER, FLAT PRECISION	125
1	1	-	A	217238-1	GENERAL INSTRUCTION PACKAGE	124
1	1	-	-	4088039	EF APPL INST 408-8039	123
						122
						121
						120
						119
						118
						117
						116
						115
						114
2	2	-	A	21024-5	WASHER, LOCK (#10) AIR ASSY	113
						112
						111
4	4	-	A	21024-4	WASHER, LOCK (NO.8) SHEAR BL	110
						109
2	2	-	A	21018-4	NUT, HEX (4-40) DRAG	108
						107
						106
2	2	-	A	21022-2	NUT, HEX SL (8-32) DRAG STUD	105
						104
						103
2	2	-	A	2-21006-6	SCR, SKT SET (4-40x.62) DRAG	102
1	1	-	A	21009-2	SCR, SKT SET (1/4-20x.25) RAM	101
2	2	-	A	21017-2	SCR, DRIVE (#2x.19) ID PLATE	100
						99
1	1	-	B	461264-1	PLATE, IDENTIFICATION	98
						97
						96
2	2	-	A	2-21002-2	SCR, BHC (8-32x.50) STRIPPER	95
4	4	-	A	2-21002-9	SCR, BHC (10-32x.75) CAP	94
1	1	-	A	22733-8	SCR, BHC (8-32x.38 LW) ANVIL	93
4	4	-	A	3-21002-3	SCR, BHC (1/4-20x.50) ST 6D PL	92
3	3	-	A	2-22733-8	SCR, BHC (1/4-20x.62) H5G	91
						90
						89
						88
2	2	-	A	2-21000-8	SCR, SHC (8-32x.62) SLUG BLADE	87
4	4	-	A	2-21000-7	SCR, SHC (8-32x.50) STRIP GUIDE	86
						85
						84
						83
						82
						81
2	2	-	A	3-21002-0	SCR, BHC (10-32x.88) SHEAR PL	80
1	-	-	A	455750-8	GUARD ASSY	79
-	REF	-	A	679532-1	INSERT, GUARD	78
						77
						76
						75
						74
						73
						72
						71

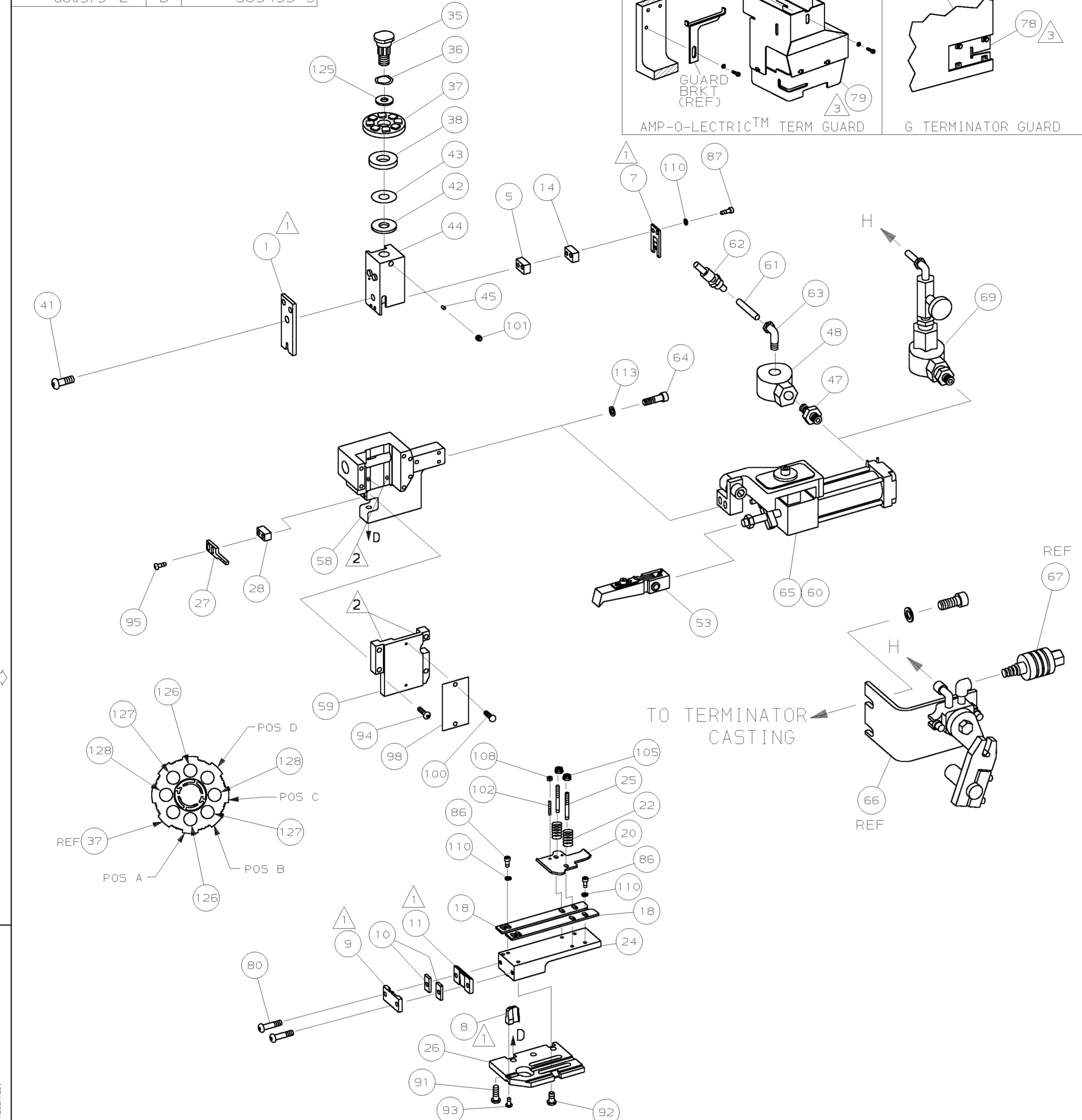

- 1 RECOMMENDED SPARE PARTS.
- 2 GREASE LIGHTLY.
- 3 GUARD MUST BE IN PLACE WHEN OPERATING APPLICATOR IN A BENCH MACHINE.
- 4 SEE DRAWING FOR COMPONENTS

QTY	REV	U/M	DWG SIZE	PART NO	DESCRIPTION	ITEM NO	
-1				BENCH MODEL G	AIR FEED		
-2				BENCH MODEL K	AIR FEED		
4	1	-	C	692655-5	AIR FEED VALVE ASSY	70	
						69	
						68	
	REF	-	A	24042-2	VALVE, SHUT OFF	67	
4	REF	-	C	692655-6	AIR FEED VALVE ASSY	66	
4	1	-	B	1-460277-5	AIR FEED ASSY (2 INCH)	65	
2	2	-	A	3-21000-9	SCR, SHC (10-32x1.00) AIR ASSY	64	
-	1	-	A	980285-2	ELBOW, SWIVEL 1/8 NPT - 1/4 T	63	
-	1	-	A	23238-1	QUICK DISCONNECT	62	
-	12.00	IN	A	27319-4	TUBING, POLY-FLO Ø.25	61	
4	-	1	-	B	1-460277-9	AIR FEED ASSY (2 INCH)	60
1	1	-	C	454220-1	CAP, RAM	59	
1	1	-	D	453736-1	HOUSING	58	
						57	
						56	
						55	
						54	
4	1	1	-	B	460680-1	FEED FINGER ASSY	53
						52	
						51	
						50	
						49	
-	1	-	A	22374-7	VALVE, QUICK EXHAUST	48	
-	1	-	A	22304-1	NIPPLE, HEX 1/8 NPT	47	
						46	
1	1	-	A	690191-1	PLUG, NYLON	45	
1	1	-	C	455674-1	RAM	44	
1	1	-	A	690125-1	WASHER, LAMINATED	43	
1	1	-	A	690124-9	WASHER, RAM	42	
1	1	-	A	7-21002-9	BOLT, CRIMPER (5/16-24x1.00)	41	
						40	
						39	
1	1	-	A	690223-2	SPACER, INSULATION DISC	38	
1	1	-	D	354777-1	WIRE DISC, PLASTIC	37	
1	1	-	A	22480-5	WASHER, SPRING	36	
1	1	-	B	690212-1	POST, RAM	35	
						34	
						33	
						32	
						31	
						30	
						29	
1	1	-	B	3-690451-2	SPACER, STRIPPER	28	
1	1	-	A	240639-1	STRIPPER	27	
1	1	-	D	455676-1	PLATE, BASE	26	
2	2	-	A	22354-8	DRAG, STUD	25	
1	1	-	B	455678-3	PLATE, STRIP GUIDE	24	
						23	
2	2	-	A	4-22281-1	SPRING, DRAG	22	
						21	
1	1	-	A	454177-1	DRAG, STOCK	20	
1	1	-	C	1-458030-2	GUIDE, STRIP (REAR)	19	
1	1	-	C	1-458031-2	GUIDE, STRIP (FRONT)	18	
						17	
						16	
						15	
1	1	-	C	3-240641-9	SPACER, SLUG BLADE	14	
						13	
						12	
						11	
1	1	-	B	240644-5	PLATE, REAR SHEAR	11	
2	2	-	C	1-240645-9	SPACER, SHEAR PLATE	10	
1	1	-	B	240642-1	PLATE, FRONT SHEAR	9	
1	1	-	D	2-456537-5	ANVIL	8	
1	1	-	B	7-240651-5	BLADE, SLUG	7	
						6	
1	1	-	C	240641-3	SPACER, SLUG BLADE	5	
						4	
						3	
						2	
1	1	-	C	1-456412-7	CRIMPER, WIRE	1	

QTY	REV	U/M	DWG SIZE	PART NO	DESCRIPTION	ITEM NO
-2				BENCH MODEL G	AIR FEED	
-1				BENCH MODEL K	AIR FEED	

MATERIAL		HT TR	FIN
MATL	-	-	-

DR	CHK	PLC	APL	REL	DATE
B. HIGMAN	C. ERISMAN	15 JAN 98	15 JAN 98	T. ELBIN	24 JUN 99

NAME	SCALE	DWG NO	SHEET	REV
END FEED HDM APPLICATOR	-	680579	1 OF 1	C

THIS DRAWING IS A CONTROLLED DOCUMENT.

THIS DRAWING IS UNRELEASED. RELEASE FOR PUBLICATION APR 15, 1998 BY AMP INCORPORATED. ALL RIGHTS RESERVED.

LOC A
DIST 66