

# NHD-C160100DiZ-FSW-FBW

## COG (Chip-On-Glass) Liquid Crystal Display Module

NHD-	Newhaven Display
C160100-	160 x 100 Pixels
DiZ-	Model (I <sup>2</sup> C)
F-	Transflective
SW-	Side White LED Backlight
F-	FSTN, Positive
B-	6:00 Optimal View
W-	Wide Temp

**RoHS Compliant**

**Newhaven Display International, Inc.**

2661 Galvin Ct.

Elgin IL, 60124

Ph: 847-844-8795

Fax: 847-844-8796

[www.newhavendisplay.com](http://www.newhavendisplay.com)

[nhtech@newhavendisplay.com](mailto:nhtech@newhavendisplay.com)

[nhsales@newhavendisplay.com](mailto:nhsales@newhavendisplay.com)

## Document Revision History

Revision	Date	Description	Changed by
0	1/06/2008	Initial Release	-
1	9/18/2009	User guide reformat	BE
2	10/14/2009	Updated Electrical Characteristic	MC
3	11/9/2009	Slave Address Updated	BE
4	11/17/2009	Slave Address Updated	MC
5	11/20/2009	Updated backlight supply current max / Updated Table of Commands	MC
6	12/14/2010	Updated backlight cable length	CL
7	8/25/16	Mechanical Drawing, Electrical & Optical Char. Updated	SB
8	3/24/17	Mechanical Drawing Updated	SB
9	5/25/17	Electrical Characteristics Updated	TM
10	5/10/18	Module Redesign	SB
11	9/11/19	Backlight Characteristics and Supply Current Updated	SB

## Functions and Features

- 160 x 100 pixels
- Built-in ST7528i (I2C) controller
- +3.0V power supply
- 1/100 duty cycle; 1/11 bias
- RoHS Compliant

1	2	3	4	5	6	7	8	
				SYMBOL	REVISION			DATE

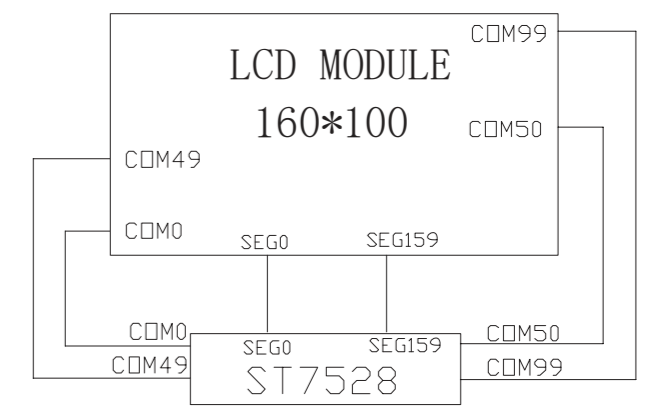
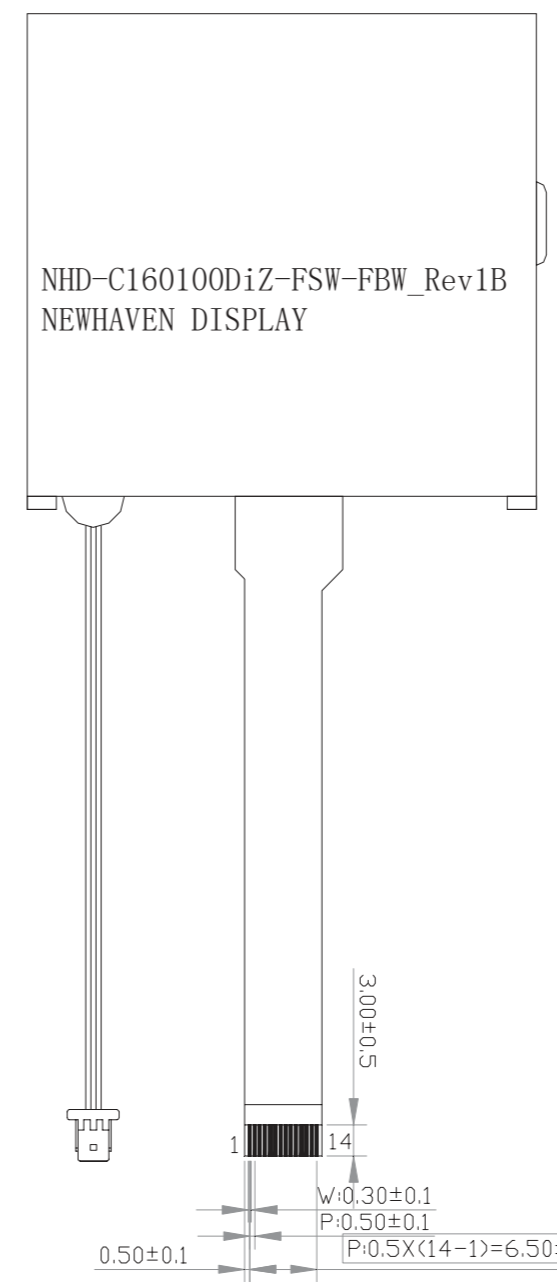
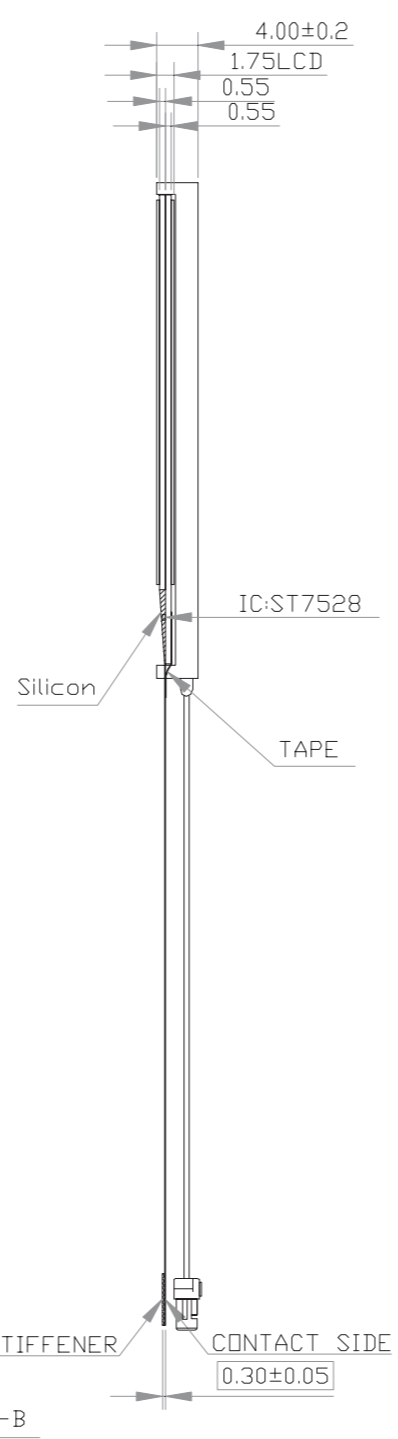
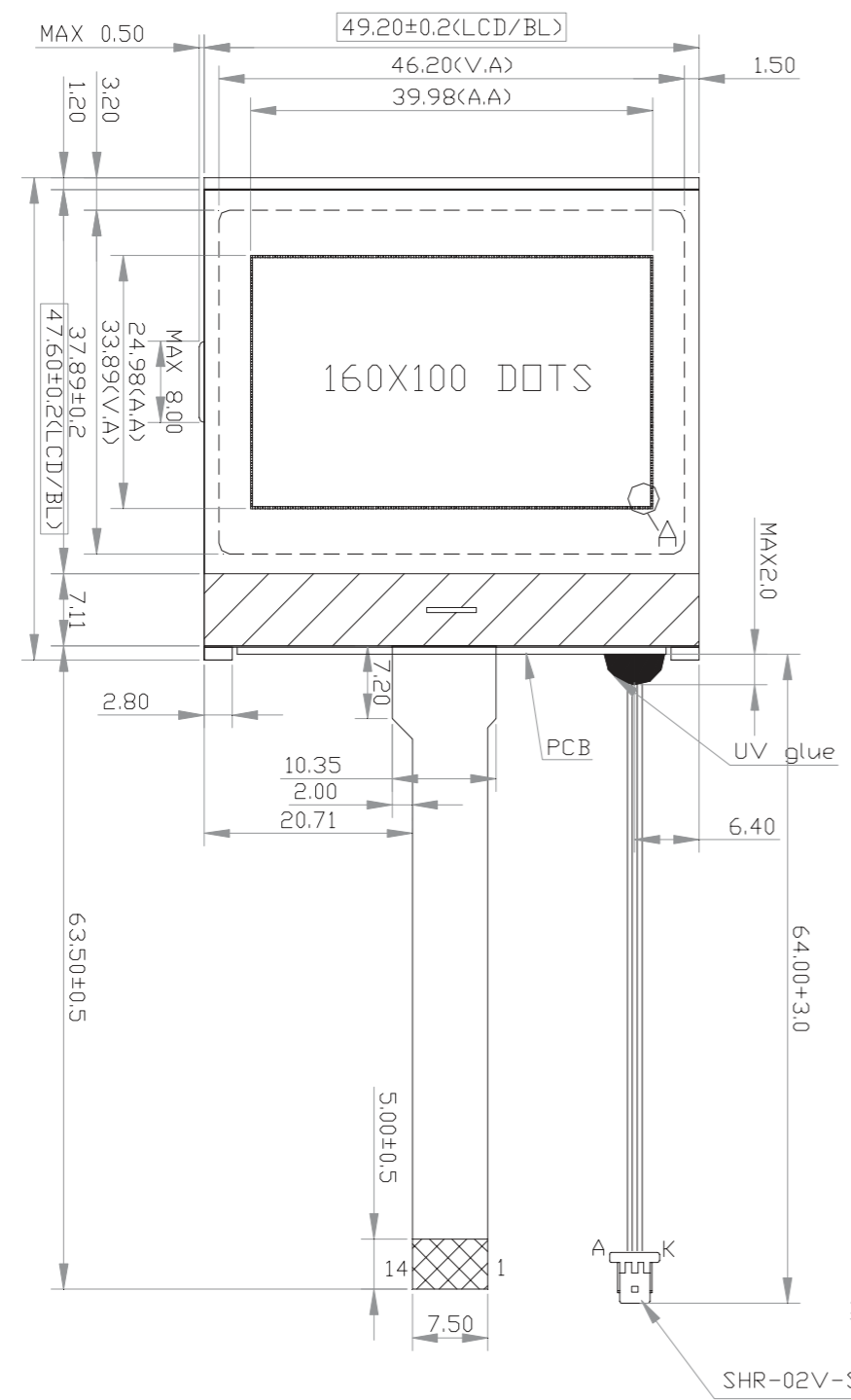

PIN	SYMBOL
1	CSB
2	RST
3	NC
4	SCL
5	SDA
6	VDD
7	VSS
8	VOUT
9	V4
10	V3
11	V2
12	V1
13	NC
14	NC

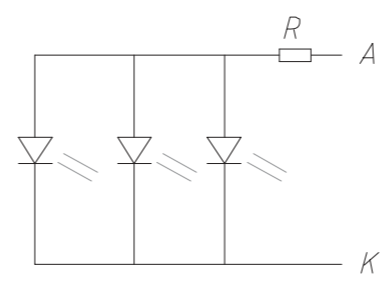
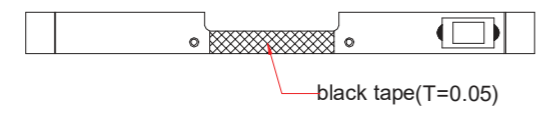
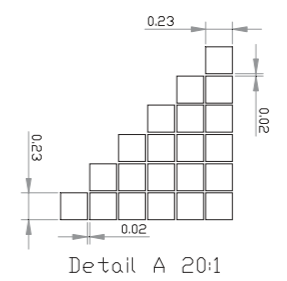

- Notes:**
1. Driver: 1/100 Duty, 1/11 Bias
  2. Display Mode: FSTN Positive / Transflective
  3. Optimal View: 6:00
  4. Voltage: 3.0V VDD, 11.5V VLCD
  5. Backlight: White LED
  6. Driver IC: ST7528I - IIC Interface

STANDARD TOLERANCE: (UNLESS OTHERWISE SPECIFIED)		
LINEAR: ±0.3mm	DRAWING/PART NUMBER: <b>NHD-C160100DiZ-FSW-FBW</b>	REVISION: <b>1B</b>
UNLESS OTHERWISE SPECIFIED: - DIMENSIONS ARE IN MILLIMETERS - THIRD ANGLE PROJECTION	DRAWN BY: S. Baxi	APPROVED BY: S. Baxi
	DRAWN DATE: 9/11/19	APPROVED DATE: 9/11/19
	DO NOT SCALE DRAWING	
	SHEET 1 OF 1	
THIS DRAWING IS SOLELY THE PROPERTY OF NEWHAVEN DISPLAY INTERNATIONAL, INC. THE INFORMATION IT CONTAINS IS NOT TO BE DISCLOSED, REPRODUCED OR COPIED IN WHOLE OR PART WITHOUT WRITTEN APPROVAL FROM NEWHAVEN DISPLAY.		

## Pin Description and Wiring Diagram

Pin No.	Symbol	External Connection	Function Description
1	CSB	MPU	Active Low Chip Select
2	RST	MPU	Active Low Reset signal
3	NC	-	No Connect
4	SCL	MPU	Serial Clock input (requires pull-up)
5	SDA	MPU	Serial Data input (requires pull-up)
6	V <sub>DD</sub>	Power Supply	Supply Voltage for LCD and logic (+3.0V)
7	V <sub>SS</sub>	Power Supply	Ground
8	V <sub>OUT</sub>	Power Supply	Connect to 1uF cap to V <sub>SS</sub> or V <sub>DD</sub>
9	V <sub>4</sub>	Power Supply	1.0uF-2.2uF cap to V <sub>SS</sub>
10	V <sub>3</sub>	Power Supply	1.0uF-2.2uF cap to V <sub>SS</sub>
11	V <sub>2</sub>	Power Supply	1.0uF-2.2uF cap to V <sub>SS</sub>
12	V <sub>1</sub>	Power Supply	1.0uF-2.2uF cap to V <sub>SS</sub>
13	NC	-	No Connect
14	NC	-	No Connect

**Recommended LCD connector:** 0.5mm pitch pins. Molex p/n: 52892-1495

**Backlight connector:** SHR-02V-S-B **Mates with:** SM02B-SRSS-TB

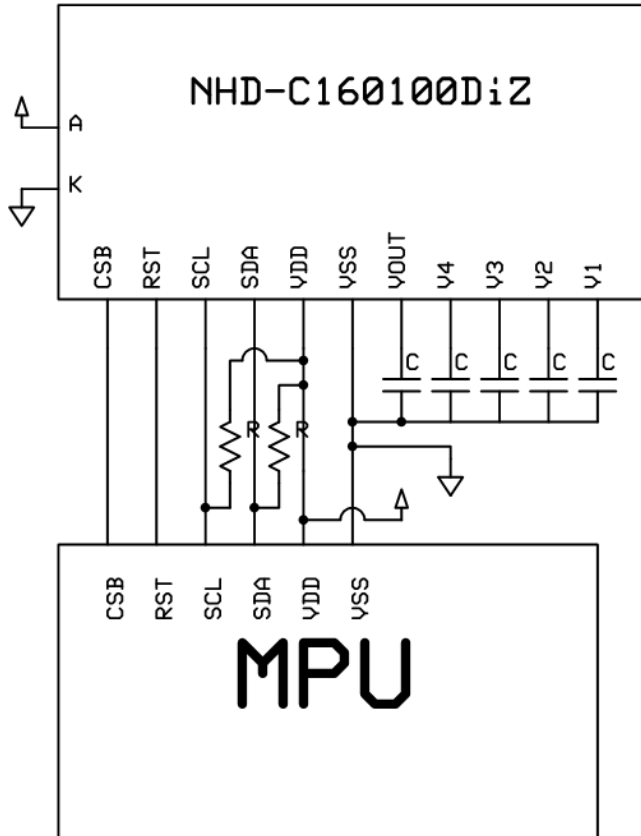

## Electrical Characteristics

Item	Symbol	Condition	Min.	Typ.	Max.	Unit
Operating Temperature Range	T <sub>OP</sub>	Absolute Max	-20	-	+70	°C
Storage Temperature Range	T <sub>ST</sub>	Absolute Max	-40	-	+80	°C
Supply Voltage	V <sub>DD</sub>	-	2.4	3.0	3.3	V
Supply Current	I <sub>DD</sub>	V <sub>DD</sub> =3.0V	0.32	0.75	1.5	mA
Supply for LCD (contrast)	V <sub>LCD</sub>	T <sub>OP</sub> =25°C	11.2	11.5	11.8	V
"H" Level input	V <sub>IH</sub>	-	2.2	-	V <sub>DD</sub>	V
"L" Level input	V <sub>IL</sub>	-	V <sub>SS</sub>	-	0.6	V
"H" Level output	V <sub>OH</sub>	-	2.4	-	V <sub>DD</sub>	V
"L" Level output	V <sub>OL</sub>	-	V <sub>SS</sub>	-	0.4	V
Backlight Supply Voltage	V <sub>LED</sub>	-	2.8	3.0	3.2	V
Backlight Supply current	I <sub>LED</sub>	V <sub>LED</sub> = 3.0V	30	50	70	mA

## Optical Characteristics

Item	Symbol	Condition	Min.	Typ.	Max.	Unit
Optimal Viewing Angles	Top	CR ≥ 2	-	15	-	°
	Bottom		-	40	-	°
	Left		-	30	-	°
	Right		-	30	-	°
Contrast Ratio	CR	-	2	10	-	-
Response Time	Rise	T <sub>OP</sub> = 25°C	-	50	200	ms
	Fall		-	300	350	ms

## Controller Information

Built-in ST7528 Controller.

Please download specification at [http://www.newhavendisplay.com/app\\_notes/ST7528.pdf](http://www.newhavendisplay.com/app_notes/ST7528.pdf)

## I<sup>2</sup>C Interface:

I2C interface requires 2 lines, Serial Data and Serial Clock. Both lines must be connected to the positive supply via a pull-up resistor. Data transfer may be initiated only when the bus is not busy.

### Bit transfer:

One data bit is transferred during each clock pulse. The data on the SDA line must remain stable during the HIGH period of the clock pulse, changes in the data line at this time will be interpreted as a control signal.

### Start and Stop conditions:

Both data and clock lines remain HIGH when the bus is not busy. A HIGH-to-LOW transition of the data line while the clock is HIGH is define as the START condition. A LOW-to-HIGH transition of the data line while the clock is HIGH is defined as the STOP condition.

### Acknowledge:

Each byte of eight bits is followed by an acknowledge bit. The ACK bit is a HIGH signal put on the bus by the transmitter, during which time the master generates an extra ACK related clock pulse. The LCD generates an ACK after the reception of each byte. The LCD will pull-down the SDA line during the ACK clock pulse, so that the SDA line is stable LOW during the HIGH period of the ACK clock pulse.

## Slave Address = 0x3F

## Timing Characteristics

### Write Mode

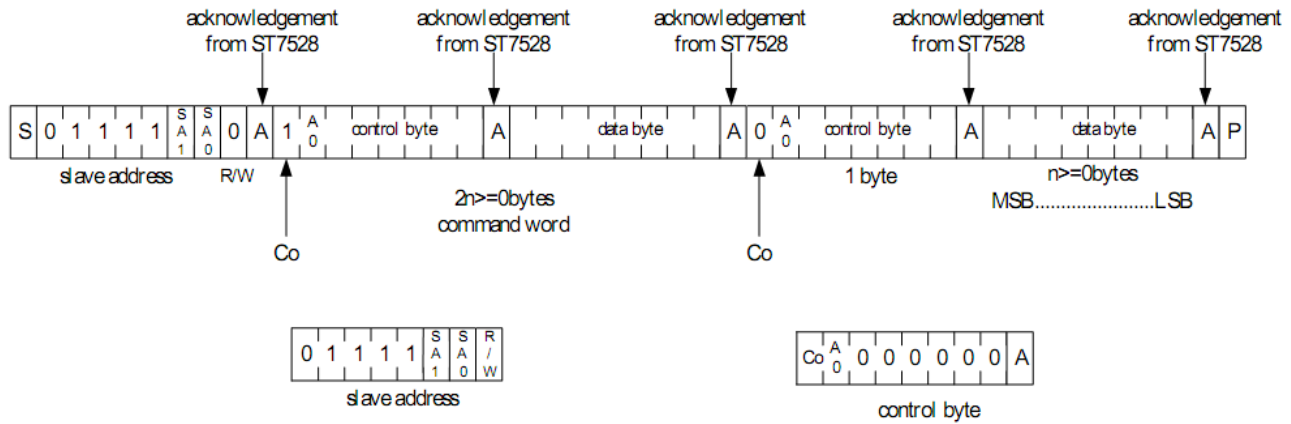

Co	0	Last control byte to be sent. Only a stream of data bytes is allowed to follow. This stream may only be terminated by a STOP or RE-START condition.
	1	Another control byte will follow the data byte unless a STOP or RE-START condition is received.

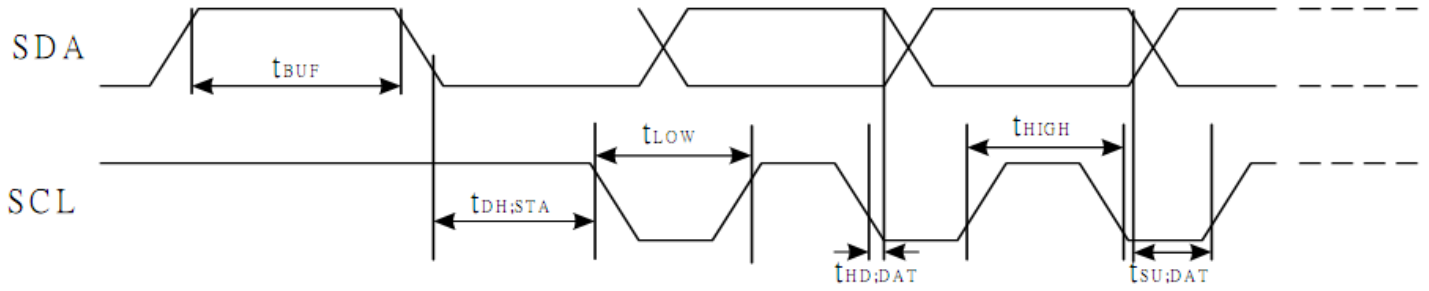

( $V_{DD}=3.3V, T_a=25^{\circ}C$ )

Item	Signal	Symbol	Condition	Rating		Units
				Min.	Max.	
SCL clock frequency	SCL	FSCLK		-	400	kHZ
SCL clock low period	SCL	TLOW		1.3	-	us
SCL clock high period	SCL	THIGH		0.6	-	us
Data set-up time	SI	TSU;Data		100	-	ns
Data hold time	SI	THD;Data		0	0.9	us
SCL,SDA rise time	SCL	TR		$20+0.1C_b$	300	ns
SCL,SDA fall time	SCL	TF		$20+0.1C_b$	300	ns
Capacitive load represented by each bus line		$C_b$		-	400	pF
Setup time for a repeated START condition	SI	TSU;SUA		0.6	-	us
Start condition hold time	SI	THD;STA		0.6	-	us
Setup time for STOP ondition		TSU;STO		0.6	-	us
Tolerable spike width on bus		TSW		-	50	ns
BUS free time between a STOP and StART condition	SCL	TBUF		1.3		us

## Table of Commands

Instruction	A0	RW	DB7	DB6	DB5	DB4	DB3	DB2	DB1	DB0	Description
<b>EXT=0 or 1</b>											
Mode Set	0	0	0	0	1	1	1	0	0	0	2-byte instruction to set Mode and FR( Frame frequency control) BE( Booster efficiency control)
	0	0	FR3	FR2	FR1	FR0	0	BE	x'	EXT	
<b>EXT=0</b>											
Read display data	1	1	Read data							Read data into DDRAM	
Write display data	1	0	Write data							Write data into DDRAM	
Read status	0	1	BUSY	ON	RES	MF2	MF1	MF0	DS1	DS0	Read the internal status
ICON control register ON/OFF	0	0	1	0	1	0	0	0	1	ICON	ICON=0: ICON disable(default) ICON=1: ICON enable & set the page address to 16
Set page address	0	0	1	0	1	1	P3	P2	P1	P0	Set page address
Set column address MSB	0	0	0	0	0	1	Y9	Y8	Y7	Y6	Set column address MSB
Set column address LSB	0	0	0	0	0	0	Y5	Y4	Y3	Y2	Set column address LSB
Set modify-read	0	0	1	1	1	0	0	0	0	0	Set modify-read mode
Reset modify-read	0	0	1	1	1	0	1	1	1	0	release modify-read mode
Display ON/OFF	0	0	1	0	1	0	1	1	1	D	D=0: Display OFF D=1: Display ON
Set initial display line register	0	0	0	1	0	0	0	0	x'	x'	2-byte instruction to specify the initial display line to realize vertical scrolling
	0	0	x'	S6	S5	S4	S3	S2	S1	S0	
Set initial COM0 register	0	0	0	1	0	0	0	1	x'	x'	2-byte instruction to specify the initial COM0 to realize window scrolling
	0	0	x'	C6	C5	C4	C3	C2	C1	C0	
Set partial display duty ration	0	0	0	1	0	0	1	0	x'	x'	2-byte instruction to set partial display duty ratio
	0	0	D7	D6	D5	D4	D3	D2	D1	D0	
Set N-line inversion	0	0	0	1	0	0	1	1	x'	x'	2-byte instruction to set N-line inversion register
	0	0	x'	x'	x'	N4	N3	N2	N1	N0	
Release N-line inversion	0	0	1	1	1	0	0	1	0	0	Release N-line inversion mode
Reverse display ON/OFF	0	0	1	0	1	0	0	1	1	REV	REV=0: normal display REV=1: reverse display
Entire display ON/OFF	0	0	1	0	1	0	0	1	0	EON	EON=0: normal display EON=1: entire display ON



# ST7528

Instruction	A0	RW	DB7	DB6	DB5	DB4	DB3	DB2	DB1	DB0	Description
<b>Ext=0</b>											
Power control	0	0	0	0	1	0	1	VC	VR	VF	Control power circuit operation
Select DC-DC step-up	0	0	0	1	1	0	0	1	DC1	DC0	Select the step-up of internal voltage converter
Select regulator register	0	0	0	0	1	0	0	R2	R1	R0	Select the internal resistance ratio of the regulator resistor
Select electronic volumn register	0	0	1	0	0	0	0	0	0	1	2-byte instruction to specify the reference voltage
	0	0	x'	x'	EV5	EV4	EV3	EV2	EV1	EV0	
Select LCD bias	0	0	0	1	0	1	0	B2	B1	B0	Select LCD bias
Bias Power Save	0	0	1	1	1	1	0	0	1	1	Bias Power save Save the Bias current consumption
	0	0	0	0	0	0	0	0	0	0	
SHL select	0	0	1	1	0	0	SHL	x'	x'	x'	COM bi-directional selection SHL=0: normal direction SHL=1: reverse direction
ADC select	0	0	1	0	1	0	0	0	0	ADC	SEG bi-direction selection ADC=0: normal direction ADC=1: reverse direction
Oscillator on start	0	0	1	0	1	0	1	0	1	1	Start the built-in oscillator
Set power save mode	0	0	1	0	1	0	1	0	0	P	P=0: normal mode P=1: sleep mode
Release power save mode	0	0	1	1	1	0	0	0	0	1	release power save mode
Reset	0	0	1	1	1	0	0	0	1	0	initial the internal function
Set data direction & display data length(DDL)	x	x'	1	1	1	0	1	0	0	0	2-byte instruction to specify the number of data bytes. (SPI mode)
	x	x'	D7	D6	D5	D4	D3	D2	D1	D0	
Select FRC and PWM mode	0	0	1	0	0	1	0	FRC	PWM1	PWM0	FRC(1:3FRC, 0:4FRC) PWM1 PWM0 0 0 45PWM 0 1 45 PWM 1 0 60PWM 1 1 ---
NOP	0	0	1	1	1	0	0	0	1	1	<u>No operation</u>
Test Instruction	0	0	1	1	1	1	x'	x'	x'	x'	<u>Don't use this instruction</u>

Instruction	A0	RW	DB7	DB6	DB5	DB4	DB3	DB2	DB1	DB0	Description
<b>EXT=1</b>											
Set white mode and 1 <sup>st</sup> frame, set pulse width	0	0	1	0	0	0	0	0	0	0	Set white mode and 1st frame
	0	0	X'	X'	GA05	GA04	GA03	GA02	GA01	GA00	
Set white mode and 2 <sup>nd</sup> frame, set pulse width	0	0	1	0	0	0	0	0	0	1	Set white mode and 2nd frame
	0	0	X'	X'	GA05	GA04	GA03	GA02	GA01	GA00	
Set white mode and 3 <sup>rd</sup> frame, set pulse width	0	0	1	0	0	0	0	0	1	0	Set white mode and 3rd frame
	0	0	X'	X'	GA05	GA04	GA03	GA02	GA01	GA00	
Set white mode and 4 <sup>th</sup> frame, set pulse width	0	0	1	0	0	0	0	0	1	1	Set white mode and 4th frame
	0	0	X'	X'	GA05	GA04	GA03	GA02	GA01	GA00	
Set gray level 1 mode	0	0	84H~87H (4 bytes)								Set gray level1
Set gray level 2 mode	0	0	88H~8BH (4 bytes)								Set gray level2
Set gray level 3 mode	0	0	8CH~8FH (4bytes)								Set gray level3
Set gray level 4 mode	0	0	90H~93H (4bytes)								Set gray level4
Set gray level 5 mode	0	0	94H~97H (4bytes)								Set gray level5
Set gray level 6 mode	0	0	98H~9BH (4 bytes)								Set gray level6
Set gray level 8 mode	0	0	A0H~A3H (4 bytes)								Set gray level8
Set gray level 9 mode	0	0	A4H~A7H (4 bytes)								Set gray level9
Set gray level 10 mode	0	0	A8H~ABH (4 bytes)								Set gray level10
Set gray level 11mode	0	0	ACH~AFH (4 bytes)								Set gray level11
Set gray level 12 mode	0	0	B0H~B3H (4 bytes)								Set gray level12
Set gray level 13 mode	0	0	B4H~B7H (4 bytes)								Set gray level13
Set gray level 14 mode	0	0	B8H~BBH (4 bytes)								Set gray level14
Set Dark mode and 1st frame, set pulse width	0	0	1	0	1	1	1	1	0	0	Set Dark mode and 1st frame, set pulse width
	0	0	X'	X'	GAF5	GAF4	GAF3	GAF2	GAF1	GAF0	
Set Dark mode and 2nd frame, set pulse width	0	0	1	0	1	1	1	1	0	1	Set Dark mode and 2nd frame, set pulse width
	0	0	X'	X'	GAF5	GAF4	GAF3	GAF2	GAF1	GAF0	
Set Dark mode and 3rd frame, set pulse width	0	0	1	0	1	1	1	1	1	0	Set Dark mode and 3rd frame, set pulse width
	0	0	X'	X'	GAF5	GAF4	GAF3	GAF2	GAF1	GAF0	
Set Dark mode and 4th frame, set pulse width	0	0	1	0	1	1	1	1	1	1	Set Dark mode and 4th frame, set pulse width
	0	0	X'	X'	GAF5	GAF4	GAF3	GAF2	GAF1	GAF0	

# Example Initialization Program

## Slave Address = 0x3F

```

/*****/
const char Slave = 0x7E;                                     //slave
address+Write bit
const char Comsend = 0x00;
const char Datasend = 0x40;

/*****/
void I2C_out(unsigned char j)                               //I2C Output
{
    int n;
    unsigned char d;
    d=j;
    for(n=0;n<8;n++){                                     //send 8 bits
        if((d&0x80)==0x80)                               //get only the MSB
            SDA=1;                                       //if 1, then SDA=1
        else
            SDA=0;                                       //if 0, then SDA=0
        d=(d<<1);                                       //shift data byte left
        SCL = 0;
        SCL = 1;                                       //clock in data
        SCL = 0;
    }
    SCL = 1;
    while(SDA==1){                                       //wait here until ACK
        SCL=0;
        SCL=1;
    }
    SCL=0;
}

/*****/
void I2C_Start(void)
{
    SCL=1;
    SDA=1;
    SDA=0;
    SCL=0;
}

/*****/
void I2C_Stop(void)
{
    SDA=0;
    SCL=0;
    SCL=1;
    SDA=1;
}

/*****/
void Show(unsigned char *text)
{
    int n,i;
    char page=0xB0;                                       //first page
    for(i=0;i<13;i++){                                    //100 pixels = 12.5 pages
        I2C_Start();
        I2C_out(Slave);
        I2C_out(Comsend);
        I2C_out(page);
        I2C_out(0x10);                                    //column address Y9:Y6
        I2C_out(0x01);                                    //column address Y5:Y2
    }
}

```

```

I2C_Stop();
I2C_Start();
I2C_out(Slave);
I2C_out(Datasend);
for(n=0;n<160;n++){
    I2C_out(*text);           //send data 4 times for grayscaling
    I2C_out(*text);
    I2C_out(*text);
    I2C_out(*text);
    ++text;                   //point to next byte of data
    delay(10);
}
I2C_Stop();
page++;                       //move to next page
}

```

```

/*****
*           Initialization           *
*****/

```

```

void init_LCD()
{
I2C_Start();
I2C_out(Slave);
I2C_out(Comsend);
I2C_out(0x48);           //partial display duty ratio
I2C_out(0x64);           // 1/100 duty
I2C_out(0xA0);           //ADC select
I2C_out(0xC8);           //SHL select
I2C_out(0x44);           //initial Com0 register
I2C_out(0x00);           //scan from Com0
I2C_out(0xAB);           //OSC on
I2C_out(0x26);           //
I2C_out(0x81);           //set electronic volume
I2C_out(0x15);           //vopcode=0x1C
I2C_out(0x56);           //set 1/11 bias
I2C_out(0x64);           //3x
delay(2);
I2C_out(0x2C);           //
I2C_out(0x66);           //5x
delay(2);
I2C_out(0x2E);           //
delay(2);
I2C_out(0x2F);           //power control
I2C_out(0xF3);           //bias save circuit
I2C_out(0x00);           //
I2C_out(0x96);           //frc and pwm
I2C_out(0x38);           //external mode
I2C_out(0x75);           //
I2C_out(0x97);           //3frc, 45 pwm
I2C_out(0x80);           //start 16-level grayscale settings
I2C_out(0x00);           //
I2C_out(0x81);           //
I2C_out(0x00);           //
I2C_out(0x82);           //
I2C_out(0x00);           //
I2C_out(0x83);           //
I2C_out(0x00);           //
I2C_out(0x84);           //
I2C_out(0x06);           //
I2C_out(0x85);           //
I2C_out(0x06);           //
I2C_out(0x86);           //
I2C_out(0x06);           //
I2C_out(0x87);           //
I2C_out(0x06);           //
I2C_out(0x88);           //

```

```
I2C_out (0x0B); //
I2C_out (0x89); //
I2C_out (0x0B); //
I2C_out (0x8A); //
I2C_out (0x0B); //
I2C_out (0x8B); //
I2C_out (0x0B); //
I2C_out (0x8C); //
I2C_out (0x10); //
I2C_out (0x8D); //
I2C_out (0x10); //
I2C_out (0x8E); //
I2C_out (0x10); //
I2C_out (0x8F); //
I2C_out (0x10); //
I2C_out (0x90); //
I2C_out (0x15); //
I2C_out (0x91); //
I2C_out (0x15); //
I2C_out (0x92); //
I2C_out (0x15); //
I2C_out (0x93); //
I2C_out (0x15); //
I2C_out (0x94); //
I2C_out (0x1A); //
I2C_out (0x95); //
I2C_out (0x1A); //
I2C_out (0x96); //
I2C_out (0x1A); //
I2C_out (0x97); //
I2C_out (0x1A); //
I2C_out (0x98); //
I2C_out (0x1E); //
I2C_out (0x99); //
I2C_out (0x1E); //
I2C_out (0x9A); //
I2C_out (0x1E); //
I2C_out (0x9B); //
I2C_out (0x1E); //
I2C_out (0x9C); //
I2C_out (0x23); //
I2C_out (0x9D); //
I2C_out (0x23); //
I2C_out (0x9E); //
I2C_out (0x23); //
I2C_out (0x9F); //
I2C_out (0x23); //
I2C_out (0xA0); //
I2C_out (0x27); //
I2C_out (0xA1); //
I2C_out (0x27); //
I2C_out (0xA2); //
I2C_out (0x27); //
I2C_out (0xA3); //
I2C_out (0x27); //
I2C_out (0xA4); //
I2C_out (0x2B); //
I2C_out (0xA5); //
I2C_out (0x2B); //
I2C_out (0xA6); //
I2C_out (0x2B); //
I2C_out (0xA7); //
I2C_out (0x2B); //
I2C_out (0xA8); //
I2C_out (0x2F); //
I2C_out (0xA9); //
I2C_out (0x2F); //
```

```

I2C_out (0xAA);           //
I2C_out (0x2F);          //
I2C_out (0xAB);          //
I2C_out (0x2F);          //
I2C_out (0xAC);          //
I2C_out (0x32);          //
I2C_out (0xAD);          //
I2C_out (0x32);          //
I2C_out (0xAE);          //
I2C_out (0x32);          //
I2C_out (0xAF);          //
I2C_out (0x32);          //
I2C_out (0xB0);          //
I2C_out (0x35);          //
I2C_out (0xB1);          //
I2C_out (0x35);          //
I2C_out (0xB2);          //
I2C_out (0x35);          //
I2C_out (0xB3);          //
I2C_out (0x35);          //
I2C_out (0xB4);          //
I2C_out (0x38);          //
I2C_out (0xB5);          //
I2C_out (0x38);          //
I2C_out (0xB6);          //
I2C_out (0x38);          //
I2C_out (0xB7);          //
I2C_out (0x38);          //
I2C_out (0xB8);          //
I2C_out (0x3A);          //
I2C_out (0xB9);          //
I2C_out (0x3A);          //
I2C_out (0xBA);          //
I2C_out (0x3A);          //
I2C_out (0xBB);          //
I2C_out (0x3A);          //
I2C_out (0xBC);          //
I2C_out (0x3C);          //
I2C_out (0xBD);          //
I2C_out (0x3C);          //
I2C_out (0xBE);          //
I2C_out (0x3C);          //
I2C_out (0xBF);          //
I2C_out (0x3C);          //end grayscale settings
I2C_out (0x38);          //
I2C_out (0x74);          //
I2C_out (0xAF);          //display on
I2C_Stop();
}
/*****/

```

## Quality Information

Test Item	Content of Test	Test Condition	Note
High Temperature storage	Endurance test applying the high storage temperature for a long time.	+80°C , 48hrs	2
Low Temperature storage	Endurance test applying the low storage temperature for a long time.	-30°C , 48hrs	1,2
High Temperature Operation	Endurance test applying the electric stress (voltage & current) and the high thermal stress for a long time.	+70°C , 48hrs	2
Low Temperature Operation	Endurance test applying the electric stress (voltage & current) and the low thermal stress for a long time.	-20°C , 48hrs	1,2
High Temperature / Humidity Operation	Endurance test applying the electric stress (voltage & current) and the high thermal with high humidity stress for a long time.	+40°C , 90% RH , 48hrs	1,2
Thermal Shock resistance	Endurance test applying the electric stress (voltage & current) during a cycle of low and high thermal stress.	-0°C 30min -> 25°C 5min -> 50°C 30min = 1 cycle For 10 cycles	
Vibration test	Endurance test applying vibration to simulate transportation and use.	10-55Hz, 1.5mm amplitude. 60 sec in each of 3 directions X,Y,Z For 15 minutes	3
Static electricity test	Endurance test applying electric static discharge.	VS=800V, RS=1.5kΩ, CS=100pF One time	

**Note 1:** No condensation to be observed.

**Note 2:** Conducted after 4 hours of storage at 25°C, 0%RH.

**Note 3:** Test performed on product itself, not inside a container.

## Precautions for using LCDs/LCMs

See Precautions at [www.newhavendisplay.com/specs/precautions.pdf](http://www.newhavendisplay.com/specs/precautions.pdf)

## Warranty Information and Terms & Conditions

[http://www.newhavendisplay.com/index.php?main\\_page=terms](http://www.newhavendisplay.com/index.php?main_page=terms)