

### FAST RECOVERY DIODES

Stud Version

#### Features

- High power FAST recovery diode series
- 1.0 to 2.0  $\mu$ s recovery time
- High voltage ratings up to 2500V
- High current capability
- Optimized turn on and turn off characteristics
- Low forward recovery
- Fast and soft reverse recovery
- Compression bonded encapsulation
- Stud version JEDEC DO-30
- Maximum junction temperature 125°C
- RoHS Compliant

110A

#### Typical Applications

- Snubber diode for GTO
- High voltage free-wheeling diode
- Fast recovery rectifier applications

#### Major Ratings and Characteristics

Parameters	SD103N/R	Units
$I_{F(AV)}$	110	A
@ $T_C$	85	°C
$I_{F(RMS)}$	173	A
$I_{FSM}$ @ 50Hz	3570	A
@ 60Hz	3730	A
$I^2t$ @ 50Hz	64	KA <sup>2</sup> s
@ 60Hz	58	KA <sup>2</sup> s
$V_{RRM}$ range	400 to 2500	V
$t_{rr}$ range	1.0 to 2.0	$\mu$ s
@ $T_J$	25	°C
$T_J$	- 40 to 125	°C

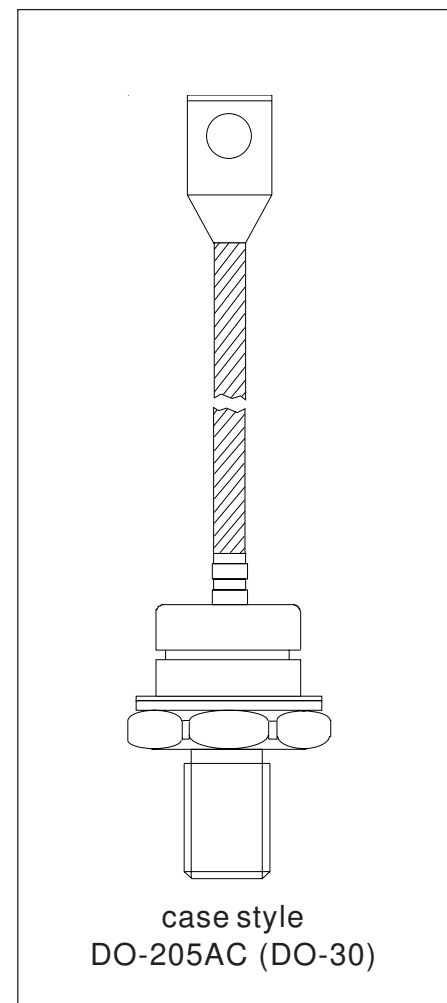

**ELECTRICAL SPECIFICATIONS**

**Voltage Ratings**

Type number	Voltage Code	V <sub>RRM</sub> max. repetitive peak and off-state voltage V	V <sub>RSM</sub> , maximum non-repetitive peak voltage V	I <sub>RRM</sub> max. T <sub>J</sub> = 125°C mA
SD103N/R..S10	04	400	500	35
	08	800	900	
	10	1000	1100	
SD103N/R..S15	12	1200	1300	
	14	1400	1500	
	16	1600	1700	
SD103N/R..S20	20	2000	2100	
	25	2500	2600	

**Forward Conduction**

Parameter	SD103N/R	Units	Conditions
I <sub>F(AV)</sub> Max. average forward current @ Case temperature	110	A	180° conduction, half sine wave.
	85	°C	
I <sub>F(RMS)</sub> Max. RMS current	173	A	DC @ 75°C case temperature
I <sub>F(SM)</sub> Max. peak, one-cycle non-repetitive forward current	3570	A	t = 10ms No voltage reappplied
	3730		t = 8.3ms reappplied
	3000		t = 10ms 100% V <sub>RRM</sub> reappplied
	3140		t = 8.3ms reappplied
I <sup>2</sup> t Maximum I <sup>2</sup> t for fusing	64	KA <sup>2</sup> s	t = 10ms No voltage reappplied
	58		t = 8.3ms reappplied
	45		t = 10ms 100% V <sub>RRM</sub> reappplied
	41		t = 8.3ms reappplied
I <sup>2</sup> √t Maximum I <sup>2</sup> √t for fusing	636	KA <sup>2</sup> √s	t = 0.1 to 10ms, no voltage reappplied
V <sub>F(TO)1</sub> Low level of threshold voltage	1.36	V	(16.7% × π × I <sub>F(AV)</sub> < I < π × I <sub>F(AV)</sub> ), T <sub>J</sub> = T <sub>J</sub> max.
V <sub>F(TO)2</sub> High level of threshold voltage	1.94		(I > π × I <sub>F(AV)</sub> ), T <sub>J</sub> = T <sub>J</sub> max.
r <sub>f1</sub> Low level of forward slope resistance	2.55	mΩ	(16.7% × π × I <sub>F(AV)</sub> < I < π × I <sub>F(AV)</sub> ), T <sub>J</sub> = T <sub>J</sub> max.
r <sub>f2</sub> High level of forward slope resistance	1.11		(I > π × I <sub>F(AV)</sub> ), T <sub>J</sub> = T <sub>J</sub> max.
V <sub>FM</sub> Max. forward voltage	2.23	V	I <sub>pk</sub> = 345A, T <sub>J</sub> = 25°C, t <sub>p</sub> = 400 μs square pulse

**Recovery Characteristics**

Code	T <sub>J</sub> = 25°C typical t <sub>rr</sub> @ 25% I <sub>RRM</sub> (μs)	Testconditions			Max. values @ T <sub>J</sub> = 125°C			
		I <sub>pk</sub> Square Pulse (A)	di/dt (A/μs)	V <sub>r</sub> (V)	t <sub>rr</sub> @ 25% I <sub>RRM</sub> (μs)	Q <sub>rr</sub> (μC)	I <sub>rr</sub> (A)	
S10	1.0	350	25	-30	1.6	21	27	
S15	1.5				2.3	61	37	
S20	2.0				3.2	75	39	

**Thermal and Mechanical Specification**

Parameter	SD103N/R	Units	Conditions
T <sub>J</sub> Max. operating temperature range	-40 to 125	°C	
T <sub>stg</sub> Max. storage temperature range	-40 to 150		
R <sub>thJC</sub> Max. thermal resistance, junction to case	0.16	K/W	DC operation
R <sub>thCS</sub> Max. thermal resistance, case to heatsink	0.10		Mounting surface, smooth, flat and greased
T Mounting torque ± 10%	15.5	N m	Not lubricated threads
	13.5		Lubricated threads
wt Approximate weight	120	g	
Case style	DO-205AC(DO-30)		See Outline Table

**ΔR<sub>thJC</sub> Conduction**

(The following table shows the increment of thermal resistance R<sub>thJC</sub> when devices operate at different conduction angles than DC)

Conduction angle	Sinusoidal conduction	Rectangular conduction	Units	Conditions
180°	0.011	0.012	K/W	T <sub>J</sub> = T <sub>J</sub> max.
120°	0.016	0.019		
90°	0.021	0.023		
60°	0.029	0.030		
30°	0.041	0.041		

**Ordering Information Table**

**Device Code**

SD	10	3	R	25	S20	P	B	C
①	②	③	④	⑤	⑥	⑦	⑧	⑨

- 1** - Diode
- 2** - Essential part number
- 3** - 3 = Fast recovery
- 4** - N = Stud Normal Polarity (Cathode to Stud)  
R = Stud Reverse Polarity (Anode to Stud)
- 5** - Voltage code: Code x 100 = V<sub>RRM</sub> (see Voltage Ratings table)
- 6** - t<sub>rr</sub> code (see Recovery Characteristics table)
- 7** - P = Stud base DO-205AC (DO-30) 1/2" 20UNF-2A  
M = Stud base DO-205AC (DO-30) M12 X 1.75
- 8** -7 B = Flag top terminals (for Cathode/ Anode Leads)  
S = Isolated lead with silicone sleeve  
(Red = Reverse Polarity; Blue = Normal Polarity)  
None = Not isolated lead
- 9** - C = Ceramic housing (over 1600V)  
V = Glass-metal seal (only up to 1600V)

Outline Table

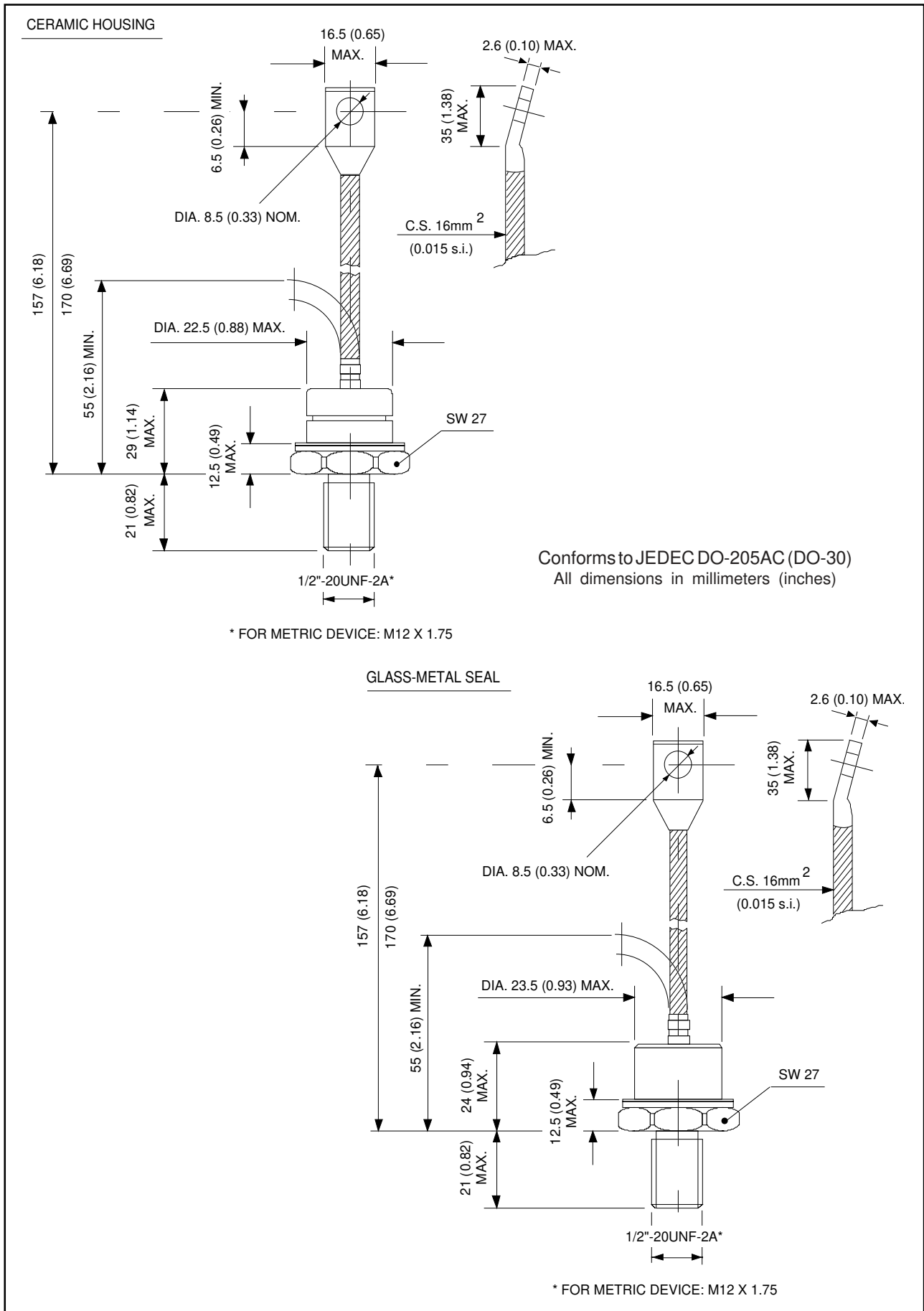

Outline Table

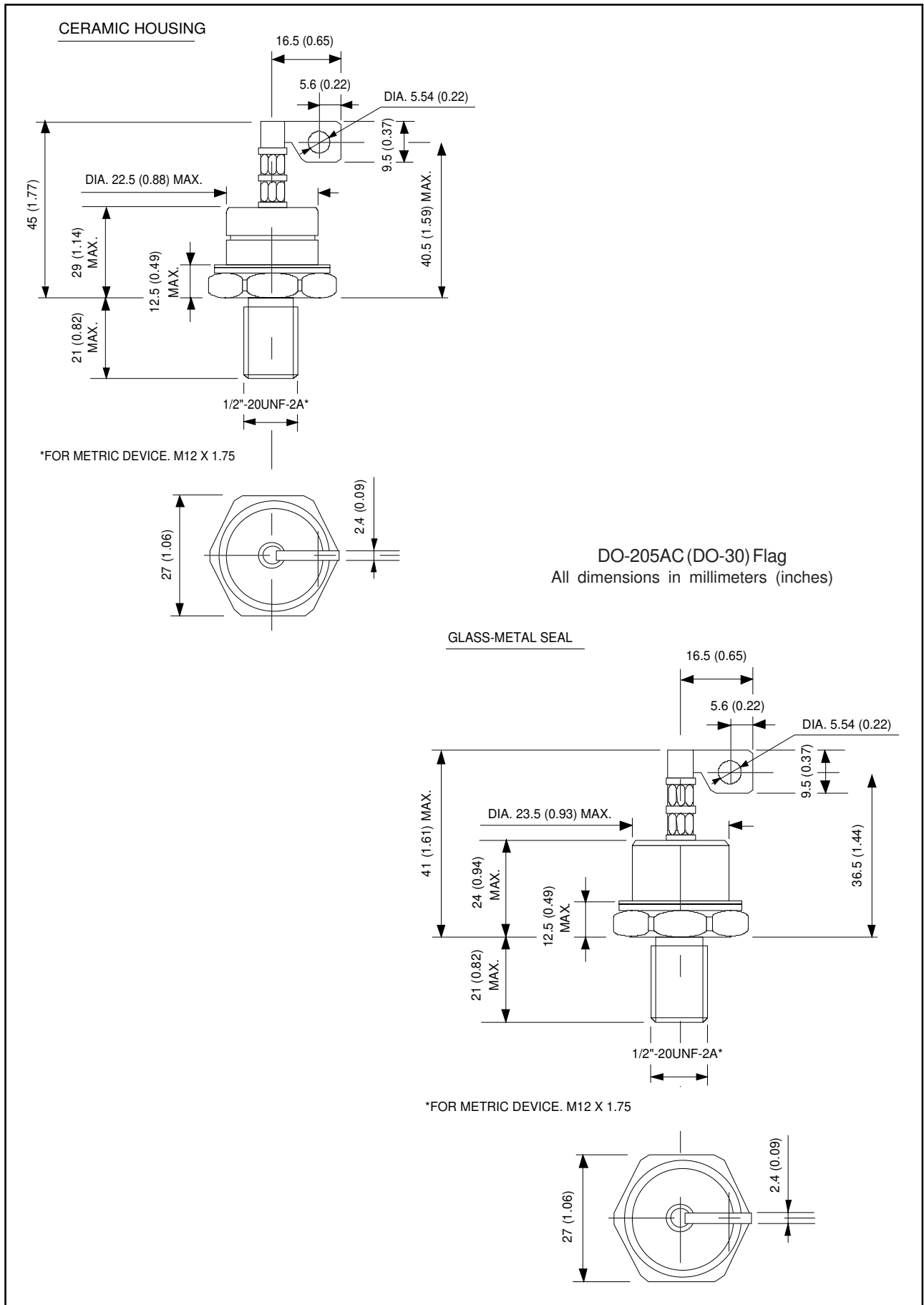

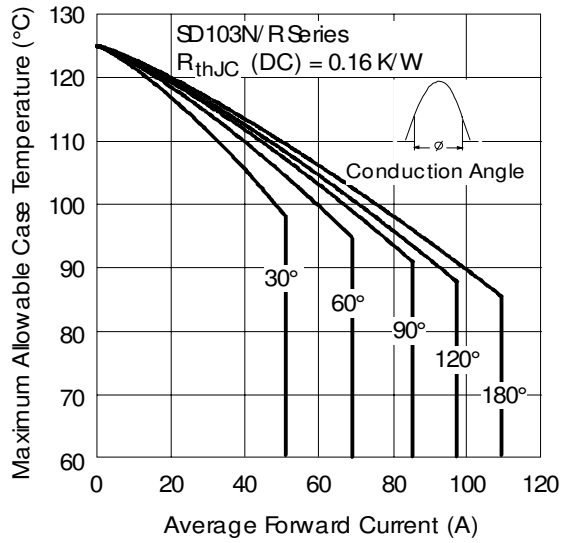

Fig. 1 - Current Ratings Characteristics

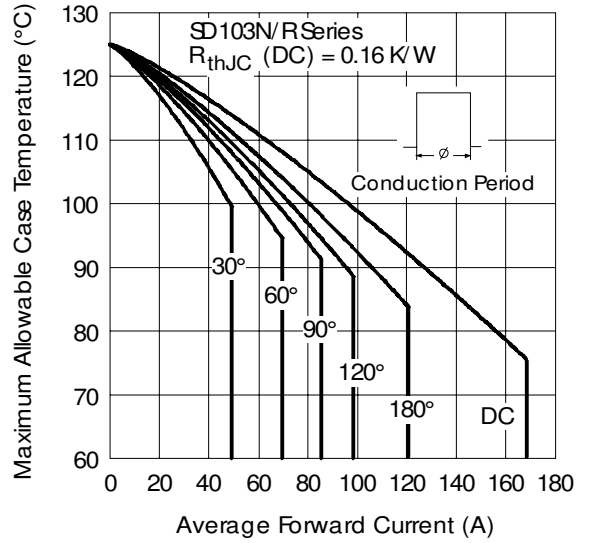

Fig. 2 - Current Ratings Characteristics

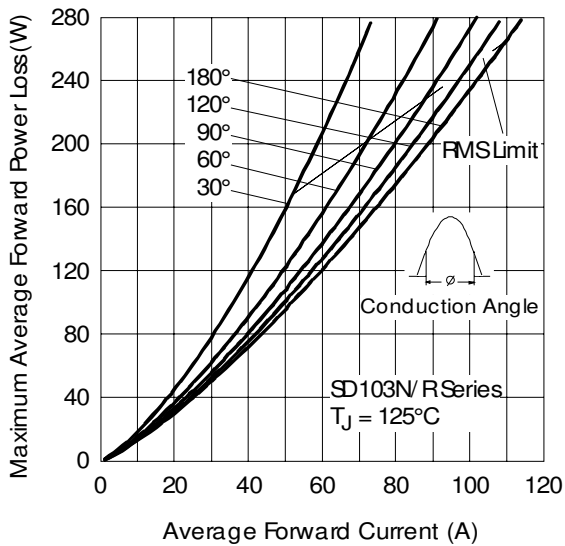

Fig. 3 - Forward Power Loss Characteristics

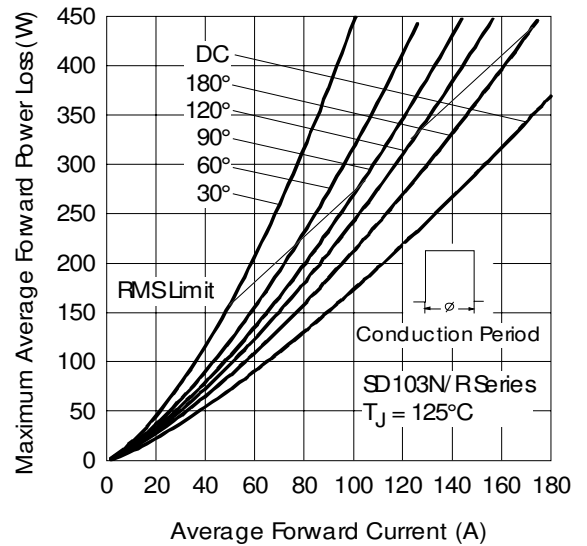

Fig. 4 - Forward Power Loss Characteristics

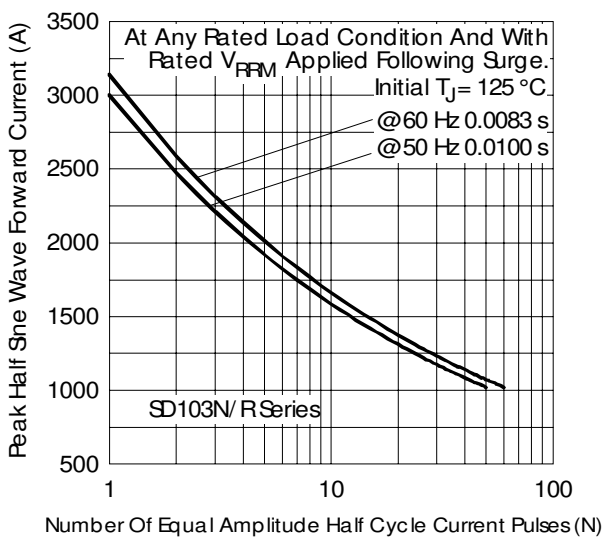

Fig. 5 - Maximum Non-repetitive Surge Current

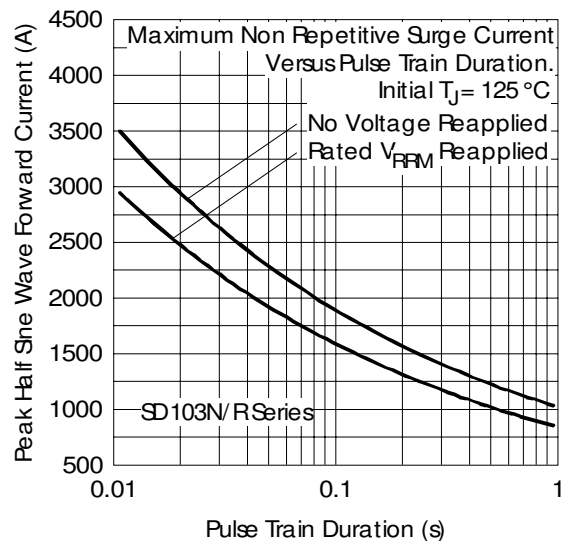

Fig. 6 - Maximum Non-repetitive Surge Current

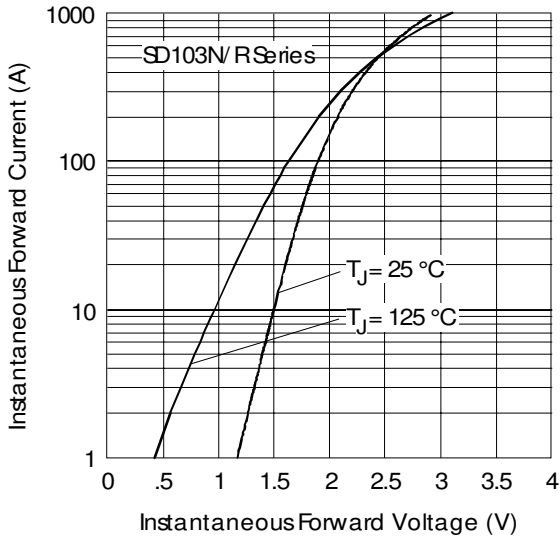

Fig. 7 - Forward Voltage Drop Characteristics

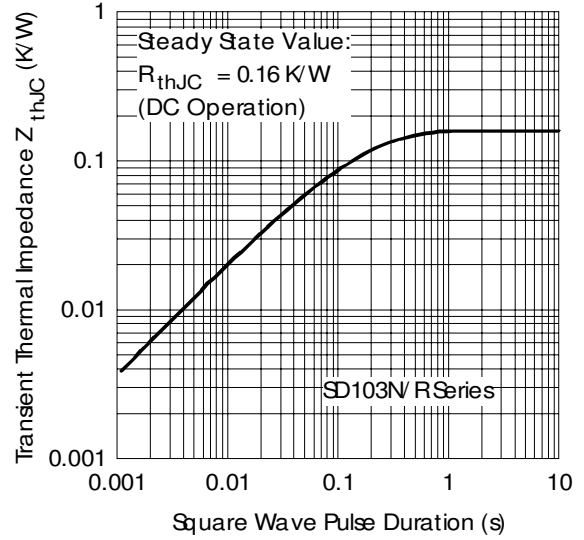

Fig. 8 - Thermal Impedance  $Z_{thJC}$  Characteristic

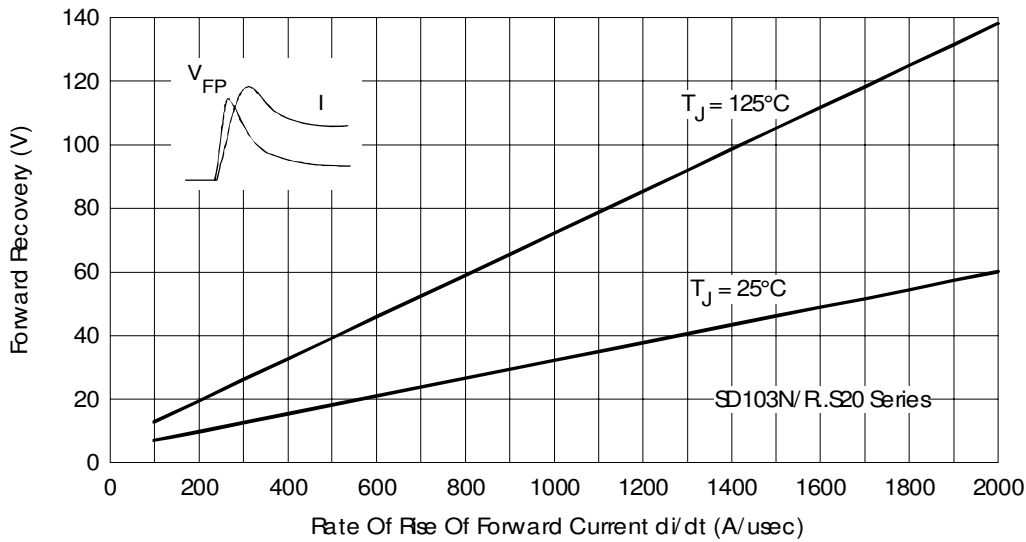

Fig. 9 - Typical Forward Recovery Characteristics

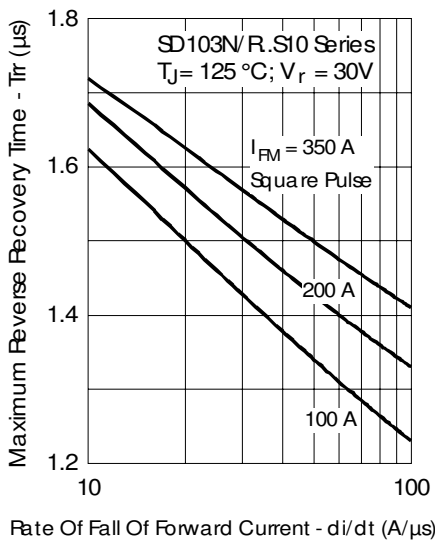

Fig. 10 - Recovery Time Characteristics

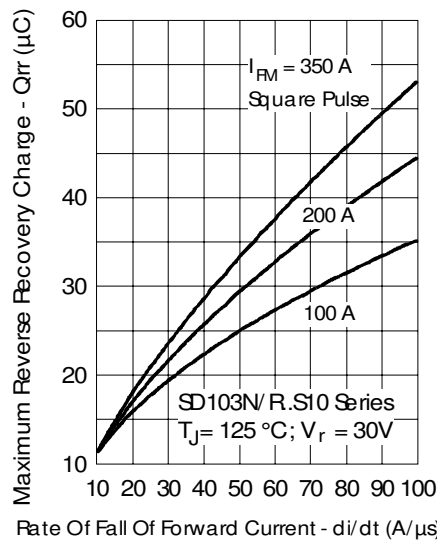

Fig. 11 - Recovery Charge Characteristics

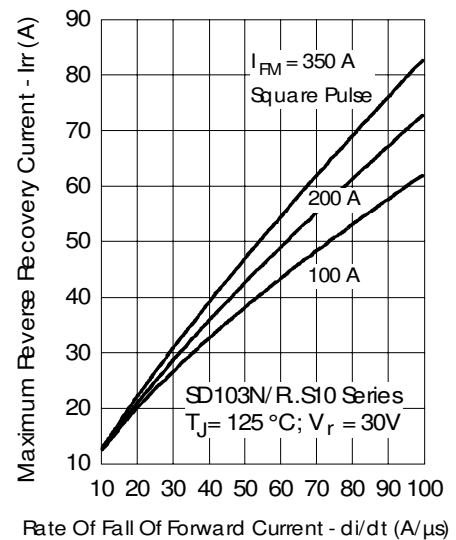

Fig. 12 - Recovery Current Characteristics

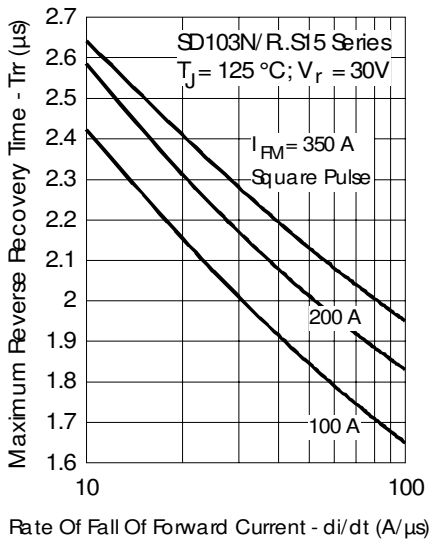

Fig. 13 - Recovery Time Characteristics

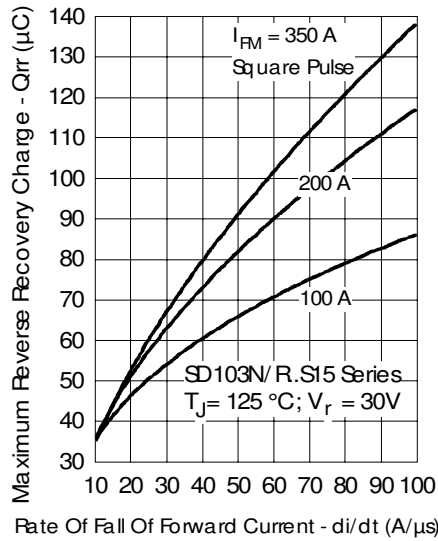

Fig. 14 - Recovery Charge Characteristics

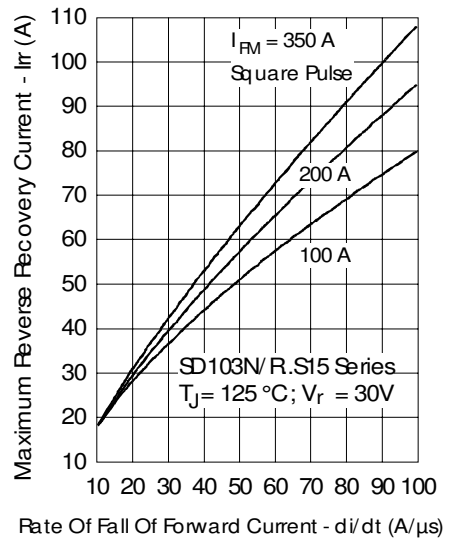

Fig. 15 - Recovery Current Characteristics

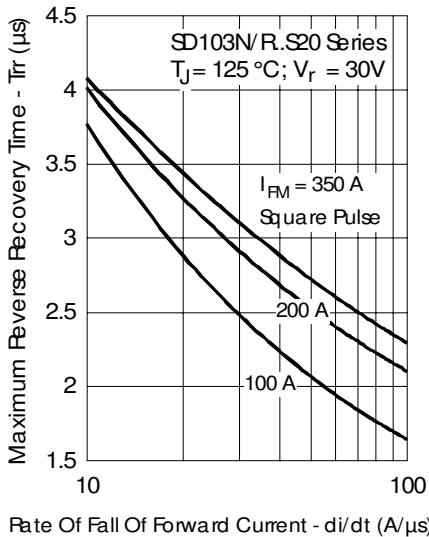

Fig. 16 - Recovery Time Characteristics

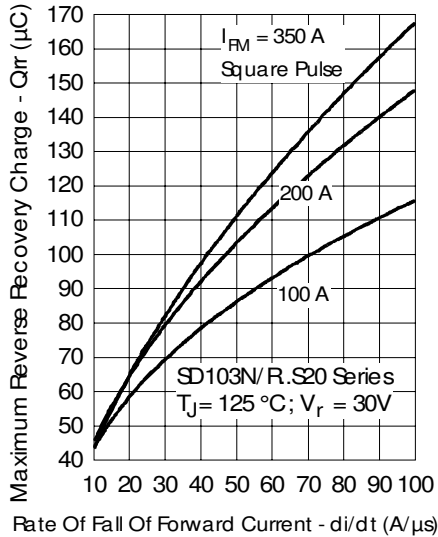

Fig. 17 - Recovery Charge Characteristics

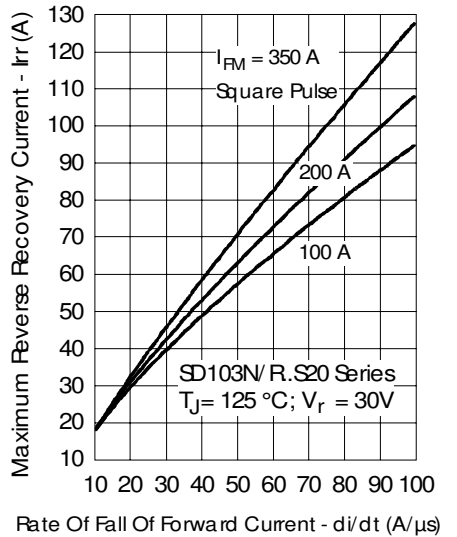

Fig. 18 - Recovery Current Characteristics

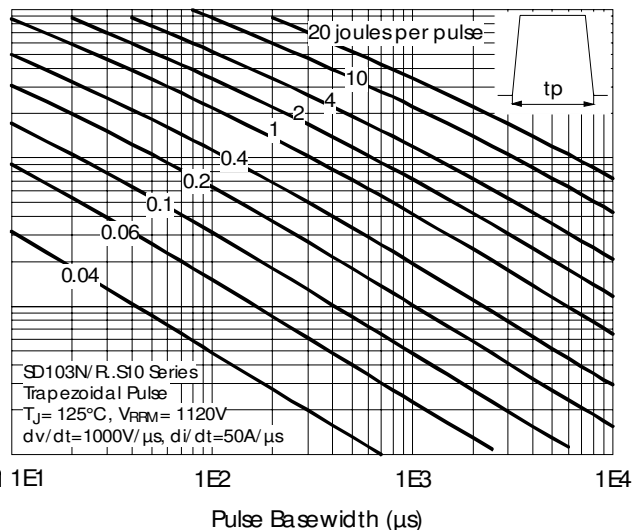
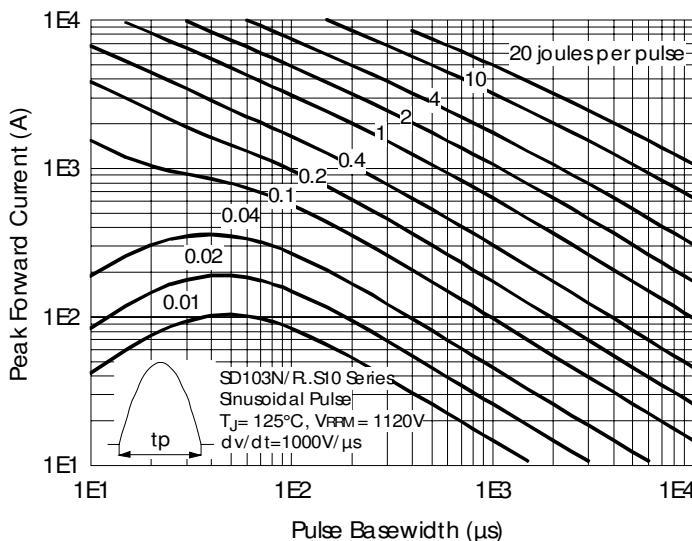

Fig. 19 - Maximum Total Energy Loss Per Pulse Characteristics



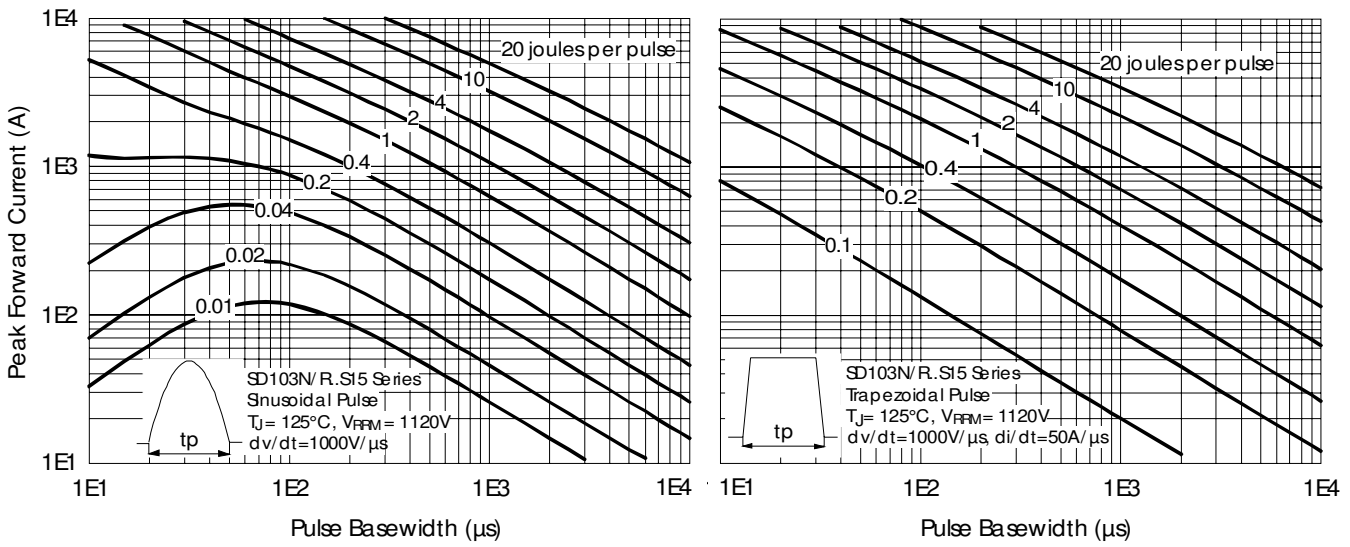

Fig. 20 - Maximum Total Energy Loss Per Pulse Characteristics

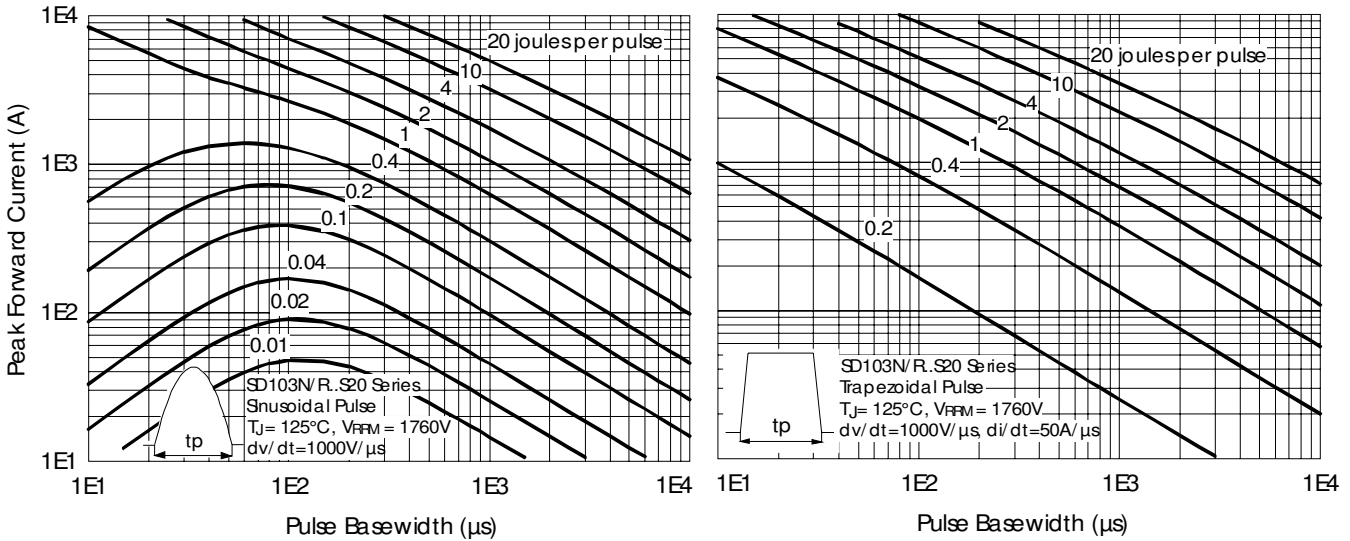

Fig. 21 - Maximum Total Energy Loss Per Pulse Characteristics

Data and specifications subject to change without notice.  
This product has been designed and qualified for Industrial Level.  
Qualification Standards can be found on IR's Web site.