

THIS DRAWING AND THE SUBJECT MATTER SHOWN THEREON ARE CONFIDENTIAL AND THE PROPERTY OF BEL/STEWART/TRP CONNECTOR AND SHALL NOT BE REPRODUCED, COPIED, OR USED IN ANY MANNER WITHOUT THE WRITTEN CONSENT OF TRP CONNECTOR.

PRODUCT MAY BE PROTECTED BY ONE OR MORE OF THE FOLLOWING US PATENTS:
 5736910 5939955 6425781 6428361 6554638 6840817 7123117
 7429195 7717749 7808751 6217391 6149050 7924130

REVISIONS				
#	LT#	DESCRIPTION	DATE	OWN APVD
3		SEE FINAL SHEET	10FEB2015	DP TY

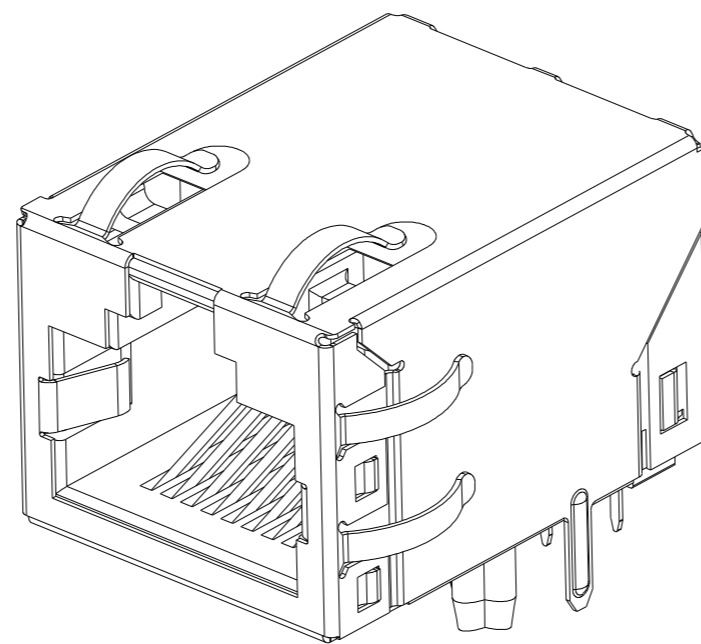
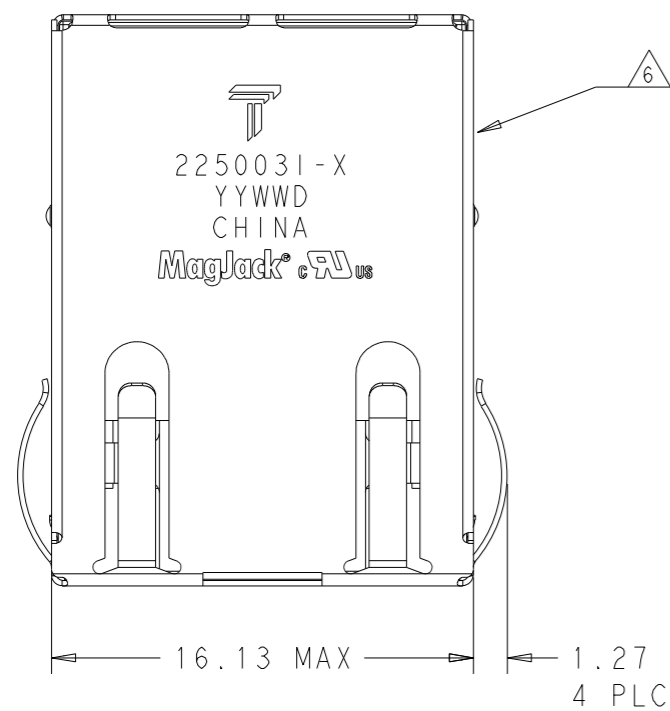

1. MATERIALS

- HOUSING: THERMOPLASTIC, FLAMMABILITY RATING UL 94V-0.
- SHIELD: BRASS 0.20mm THICK, PREPLATED WITH 0.76um MIN SEMI-BRIGHT NICKEL. SOLDER TABS POST DIPPED WITH 2.54um MIN SAC SOLDER.
- CONTACTS: PHOSPHOR BRONZE 0.46mm X 0.30mm, PHOSPHOR BRONZE, 1.27um MIN NICKEL UNDERPLATE, WITH 1.27um MIN GOLD PLATING AT MATING INTERFACE AND 2.54um MIN MATTE TIN ON SOLDER TAILS, OR 1.27um MIN NICKEL UNDERPLATE, WITH 0.05um GOLD PLATING OVER 0.76um MIN PALLADIUM NICKEL PLATING AT MATING INTERFACE AND 2.54um MIN MATTE TIN ON SOLDER TAILS.
- SOLDER TAILS: 0.25mm THICK, PHOSPHOR BRONZE, 1.27um MIN OVERALL NICKEL UNDERPLATE, 3um TIN PLATE

△2 RJ45 JACK CAVITY CONFORMS TO FCC RULES AND REGULATIONS PART 68 SUB PART F.

△3 MAGNETICS

- APPLICATION: 10/100 BASE-T
- IMPEDANCE: 100 OHMS
- TURNS RATIO (CHIP:CABLE): TX = 1:1, RX = 1:1
- OPEN CIRCUIT INDUCTANCE (OCL): 350uH MIN @100kHz, 0.1VRMS, 8mADC BIAS FROM 0°C TO +70°C, TX AND RX
- PERFORMANCE @ 25°C:
- INSERTION LOSS (IL): 1.1dB MAX FROM 0.5MHz TO 100MHz
- RETURN LOSS (RL): 18dB MIN FROM 0.5MHz TO 30MHz
- 18-20LOG(f/30)dB MIN FROM 30.1MHz TO 60MHz
- 12dB MIN FROM 60.1MHz TO 80MHz
- CROSSTALK ATTENUATION: 35dB MIN FROM 0.5MHz TO 40MHz
- 33-20LOG(f/50)dB MIN FROM 40.1MHz TO 100MHz
- COMMON MODE REJECTION RATIO (CMRR): 30dB MIN FROM 0.5MHz TO 100MHz
- ISOLATION VOLTAGE: 2250VDC FOR 60 SECONDS WITH A RISE TIME OF 500 V/SEC

4. OPERATING TEMPERATURE: FROM 0°C TO +70°C.

△5 INDICATED MAGNETIC CONNECTIONS ARE SYMMETRICAL TO SUPPORT AUTO-MDI/MDIX.

△6 TRP CONNECTOR LOGO, PART NUMBER, DATE CODE, COUNTRY OF ORIGIN AND AGENCY APPROVAL MARKING IN APPROXIMATE LOCATION SHOWN.

7. PART SHOULD BE RECOMMENDED FOR WAVE SOLDERING PROCESS, PREHEAT TEMPERATURE IS 120°C TO 160°C, 120 SECONDS TO 180 SECONDS, PEAK WAVE SOLDERING TEMPERATURE IS 260°C MAX, 10 SECONDS MAX.

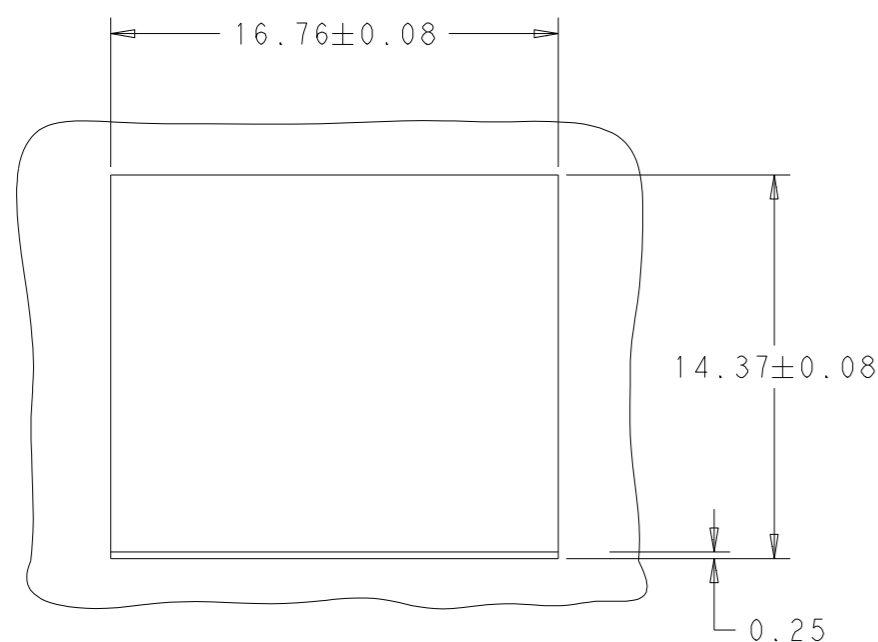
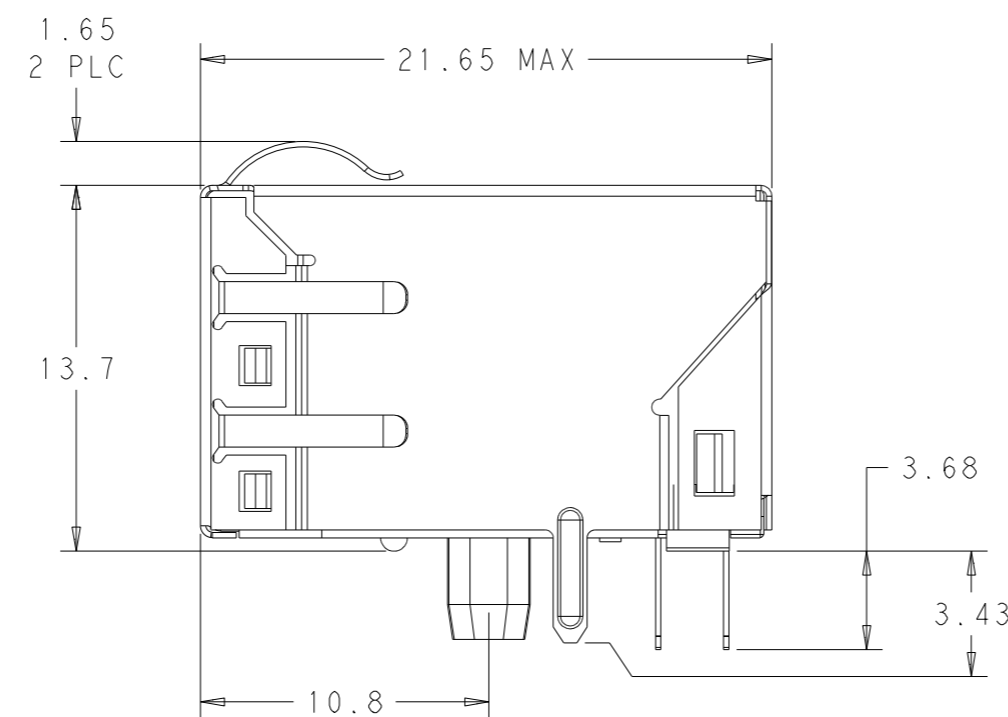
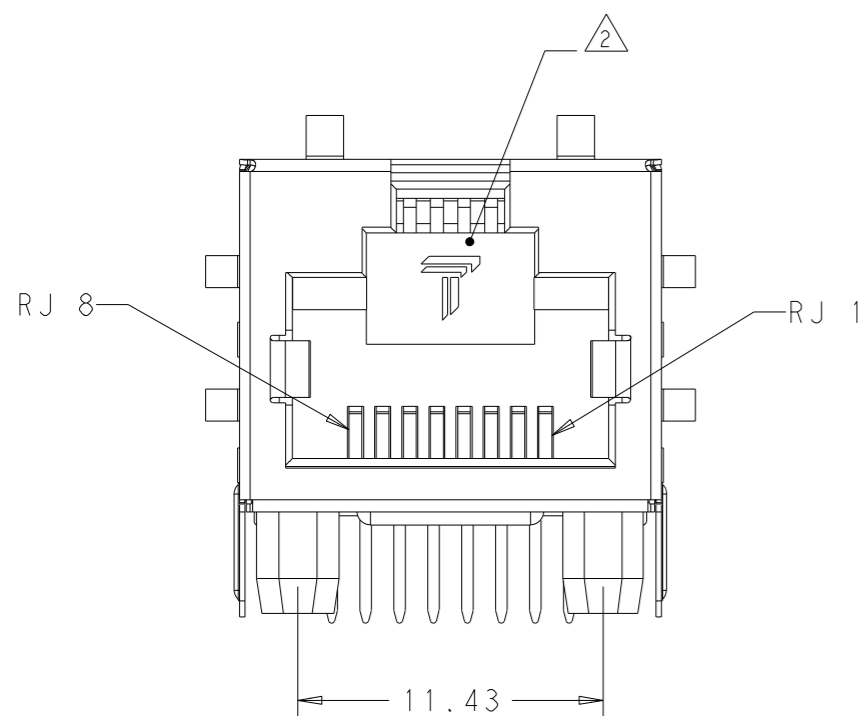

SUGGESTED PANEL CUTOUT

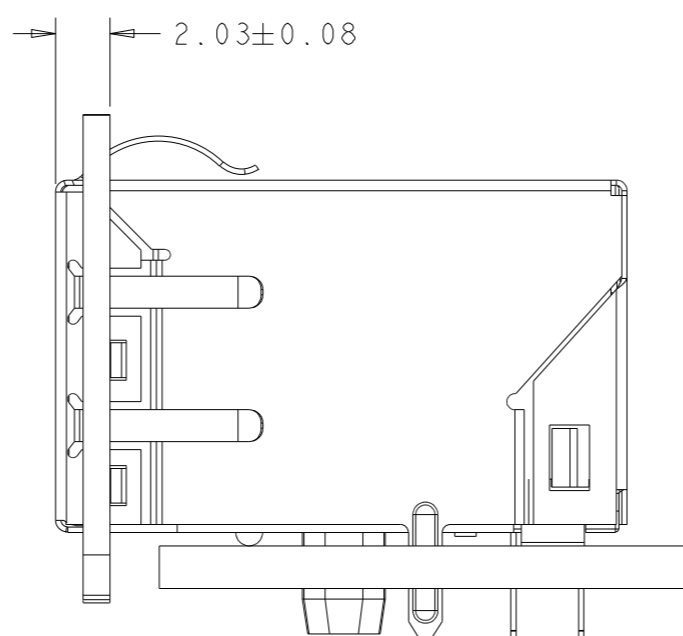

2250031-1

PART NUMBER

THIS DRAWING IS A CONTROLLED DOCUMENT.		OWN ROY LIU 03JUN2013	DONGGUAN CHINA a bel group
DIMENSIONS: mm		CHK TOWER YU / FRANK LIU 03JUN2013	
TOLERANCES UNLESS OTHERWISE SPECIFIED:		APVD TONY YUAN 03JUN2013	
0 PLC ±0.25 1 PLC ±0.25 2 PLC ±0.25 3 PLC ±0.25 4 PLC ± ANGLES ± APPLICATION SPEC	MODEL NAME MAGJACK SINGLE NON-POE	DESC 1X1 766P9 10/100 TAB UP W/O LED	SIZE A1 CAGE CODE DRAWING NO. C=2250031 RESTRICTED TO
PRODUCT SPEC	CUSTOMER DRAWING	SCALE 5:1	SHEET 1 OF 3 REV 3

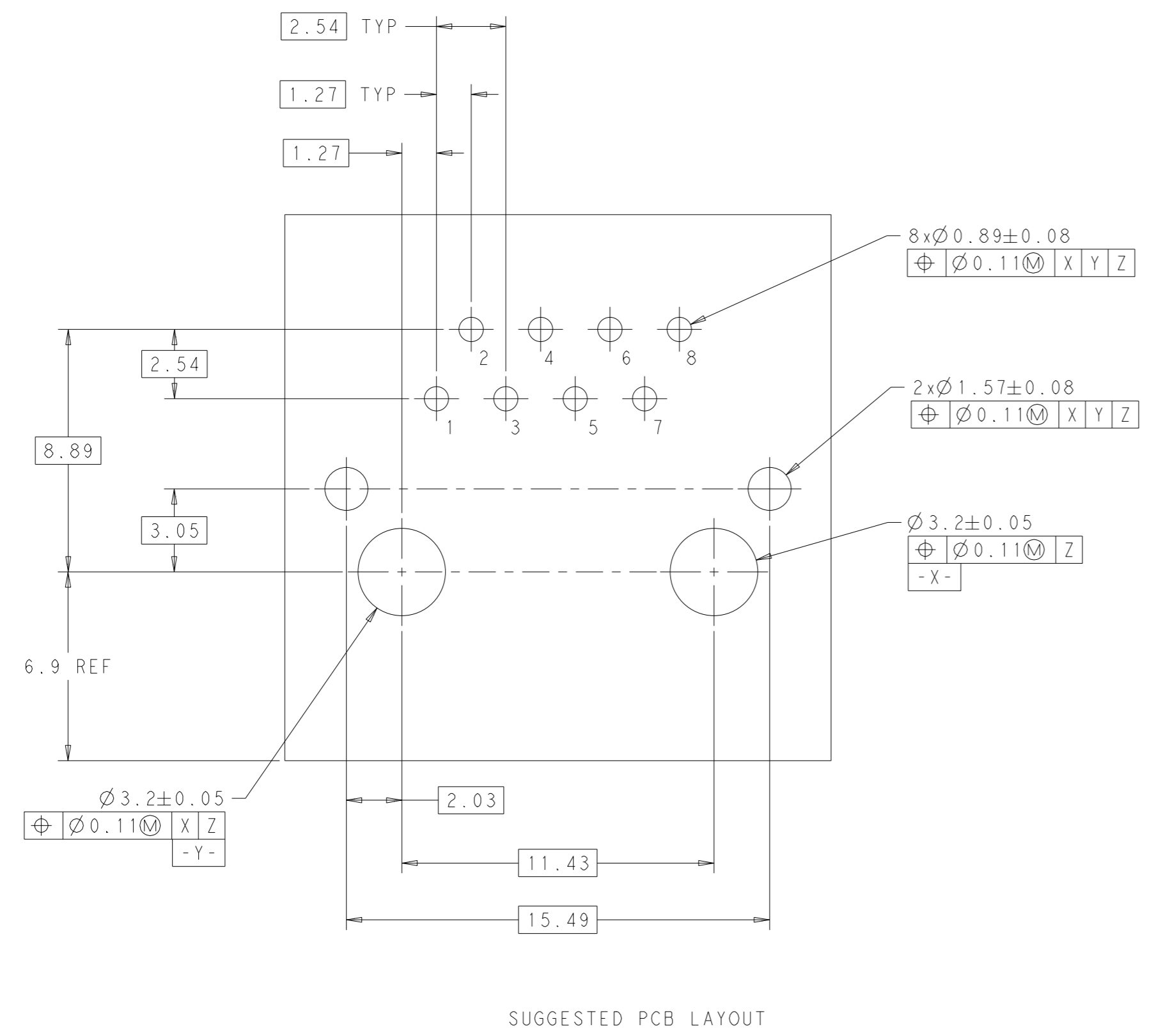

SUGGESTED PCB LAYOUT

766P9 SERIES MAGNETIC CIRCUIT $\triangle 3 \triangle 5$

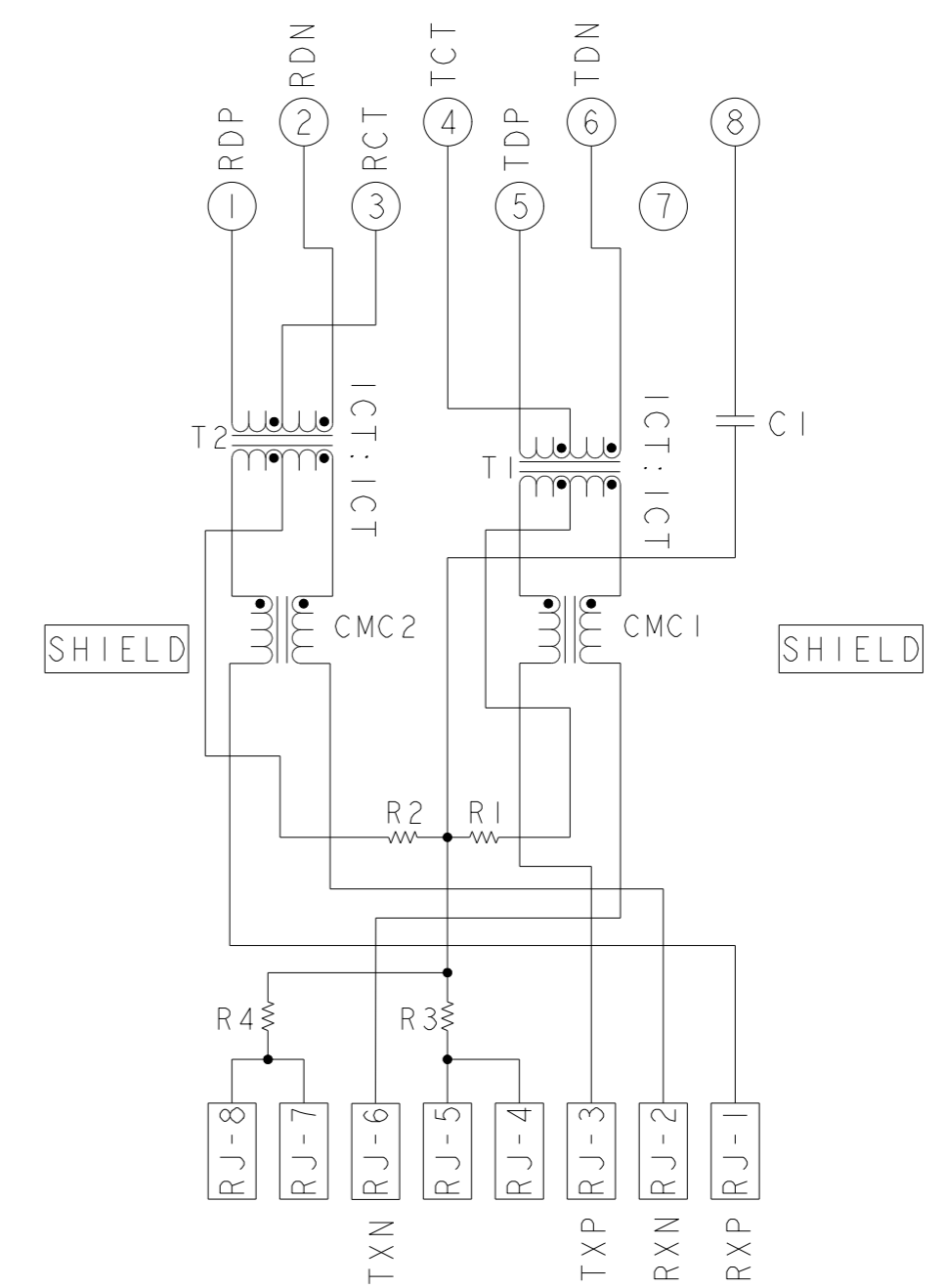

CI=1000pF, 2kV CAPACITOR
 R1-R4 = 75 OHMS, RESISTORS

THIS DRAWING IS A CONTROLLED DOCUMENT.		DWN ROY LIU 03JUN2013	 DONGGUAN CHINA a bel group
DIMENSIONS: mm		CHK TOWER YU / FRANK LIU 03JUN2013	
TOLERANCES UNLESS OTHERWISE SPECIFIED: 0 PLC ± 0.25 1 PLC ± 0.25 2 PLC ± 0.25 3 PLC ± 0.25 4 PLC \pm ANGLES \pm APPLICATION SPEC \pm		APVD TONY YUAN 03JUN2013	
PRODUCT SPEC	APPLICATION SPEC	MODEL NAME MAGJACK	DESC IXI 766P9 10/100 TAB UP W/O LED
		SIZE A1	CAGE CODE C=2250031
		RESTRICTED TO	
CUSTOMER DRAWING		SCALE 5:1	SHEET 2 OF 3
		REV 3	

C_2250031					STOCK DISPOSITION			
REVISION HISTORY					A: CONTINUE AS IS B: REWORK C: SCRAP		D: USE OLD FIRST E: PARTS TO CONFORM F: OTHER	
DATE	REV	CHANGES	REASON	APPROVAL	INVENTORY (A,B,C,D,E,F)	WORK IN PROCESS (A,B,C,F)	SUPPLIER ORDERS (A,E,F)	OPEN CUST ORDERS (A,E,F)
03JUN2013	1	-	INITIAL RELEASE	TONY YUAN	-	-	-	-
28AUG2014	2	SHEET 1, C6: CHANGE 1.27 TO 1.65	PRODUCT IMPROVEMENT	TONY YUAN	-	-	-	-
10FEB2015	3	EC-1411035 COMPANY LOGO CHANGE	MARKET REQUEST	TONY YUAN	-	-	-	-

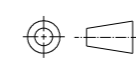
THIS DRAWING IS A CONTROLLED DOCUMENT.		OWN ROY LIU	03JUN2013	 trp CONNECTOR <small>a bel group</small>	DONGGUAN CHINA
DIMENSIONS: mm		CHK TOWER YU / FRANK LIU	03JUN2013		
		APPROV TONY YUAN	03JUN2013		
0 PLC ±0.25 1 PLC ±0.25 2 PLC ±0.25 3 PLC ±0.25 4 PLC ±0.25 ANGLES ±°		TOLERANCES UNLESS OTHERWISE SPECIFIED: APPLICATION SPEC ±°		MODEL NAME MAGJACK	DESC IXI 766P9 10/100 TAB UP W/O LED
PRODUCT SPEC		SINGLE NON-POE		SIZE A1	CAGE CODE C=2250031
CUSTOMER DRAWING		SCALE 5:1		SHEET 3 OF 3	REV 3