



80x80x15mm

- Airflow: 23.5~50.2 CFM
- Static Pressure: 1.4~5.8 mm-H₂O
- Blade / Housing: Plastic Material UL 94V-0 P.B.T.
- Lead Wire: UL1007 #26 AWG
- Weight: 50.0 g

DC AXIAL FAN

DC BLOWER

XTREME SERIES

AC AXIAL FAN

Model No.	Bearing	Rated Voltage	Operating Voltage Range	Speed	Max. Airflow	Max. Static Pressure	Current	Power Consumption	Life at 40°C L10	P-Q Curve	Noise Level
		VDC	VDC	RPM	CFM	mm-H ₂ O	mA	W	Hour		dB(A)
YW08015012BL-Q	2B	12	7~13.2	2100	23.5	1.4	70	0.84	80000	5	19.0
YW08015012BM-Q	2B		7~13.2	2600	29.1	1.9	100	1.20	80000	4	27.0
YW08015012BH-Q	2B		7~13.2	3200	35.8	2.7	190	2.28	75000	3	33.0
YW08015012BS-Q	2B		7~13.2	3900	43.6	4.3	250	3.00	65000	2	38.5
YW08015012BSS-Q	2B		7~13.2	4500	50.2	5.8	380	4.56	65000	1	42.0
YW08015012LL-Q	L		7~13.2	2100	23.5	1.4	90	1.08	50000	5	19.0
YW08015012LM-Q	L		7~13.2	2600	29.1	1.9	140	1.68	50000	4	27.0
YW08015012LH-Q	L		7~13.2	3200	35.8	2.7	250	3.00	50000	3	30.5
YW08015012LS-Q	L		7~13.2	3900	43.6	4.3	330	3.96	50000	2	35.0

2B: 2-ball bearing L: sintetico bearing S: sleeve bearing

Voltage Available

05 12 24 48

Bearing System Available

2B L S

Function Available

1 6 5 4 3 2 7 8 9 10 11 14 12 13

PERFORMANCE P-Q CURVE

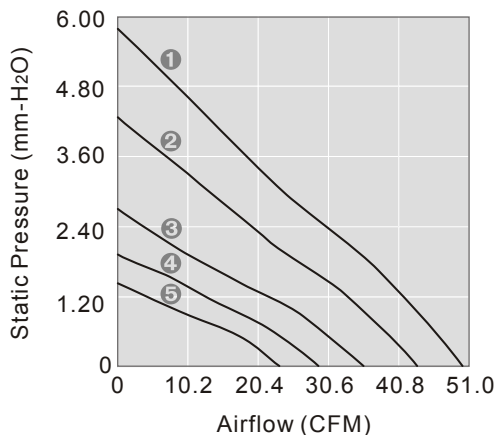

OUTLINE DIMENSIONS

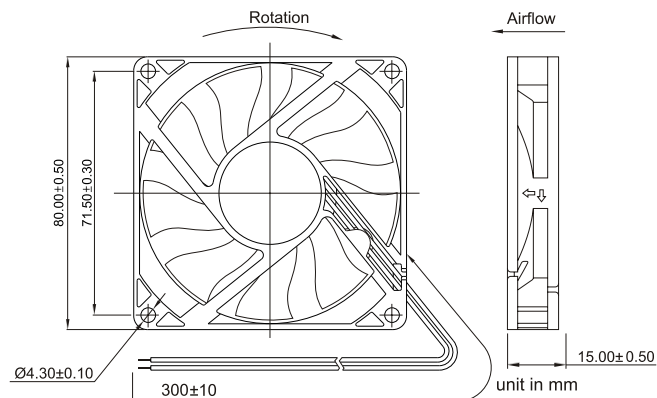

Please refer to *Model Numbering System* for bearing, function and speed level indication. Specifications are subject to changes without notice. Please refer to the formally issued product specification via contacting Y.S. TECH sales department. Visit Y.S. TECH web site at <http://www.ystechusa.com/> for updated information. Customized Specifications are designed accordingly