

Evaluating the AD7172-4 Low Power 24-Bit, 31.25 kSPS, Sigma-Delta ADC with True Rail-to-Rail Buffers

FEATURES

Full featured evaluation board for the **AD7172-4**
 PC control in conjunction with the system demonstration
 platform (SDP, see the **EVAL-SDP-CB1Z** from
 Analog Devices, Inc., for additional information)
 PC software for control and data analysis (time domain)
 Standalone capability

EVALUATION KIT CONTENTS

EVAL-AD7172-4SDZ evaluation board
 Evaluation software CD
 7 V to 9 V ac to dc adapter
 Plastic screw washer set

EQUIPMENT NEEDED

DC signal source

GENERAL DESCRIPTION

The **EVAL-AD7172-4SDZ** evaluation kit features the **AD7172-4**, a 24-bit, 31.25 kSPS analog-to-digital converter (ADC) with integrated rail-to-rail analog input buffers, on-board power supply regulation, and an external amplifier section for amplifier evaluation. A 7 V to 9 V ac to dc adapter is regulated to 5 V and 3.3 V; this voltage supplies the **AD7172-4** and support components. The **EVAL-AD7172-4SDZ** connects to a USB port of a PC via the **EVAL-SDP-CB1Z** (SDP-B) controller board.

The **EVAL-AD7172-4SDZ** evaluation software fully configures the **AD7172-4** device functionality via a user accessible register interface and provides dc time domain analysis in the form of waveform graphs, histograms, and associated noise analysis for ADC performance evaluation.

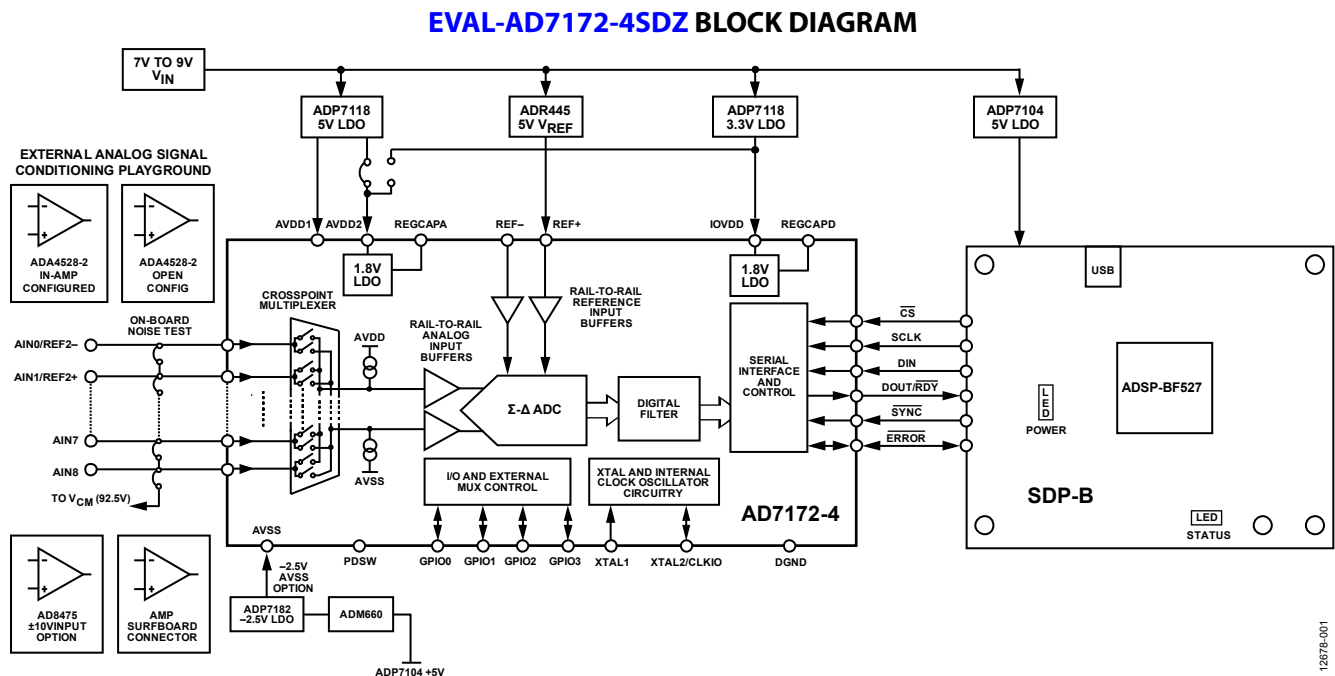

Figure 1.

TABLE OF CONTENTS

Features	1	Analog Inputs.....	6
Evaluation Kit Contents.....	1	Reference Options	6
Equipment Needed.....	1	Evaluation Board Software	7
General Description	1	Software Installation	7
EVAL-AD7172-4SDZ Block Diagram	1	Setting Up the System for Data Capture	9
Revision History	2	Evaluation Board Software Operation.....	10
EVAL-AD7172-4SDZ Quick Start Guide.....	3	Overview of the Main Window.....	11
Recommended Quick Start Guide	3	Configuration Tab (1).....	11
Quick Start Noise Test	3	Waveform Tab (18).....	12
Evaluation Board Hardware	4	Histogram Tab (18).....	13
Device Description.....	4	Modelled Performance Tab (31).....	14
Hardware Link Options.....	4	Registers Tab	17
Sockets and Connectors	5	Exiting the Software	17
Serial Interface	5	Evaluation Board Schematics and Artwork.....	18
Power Supplies	5	Ordering Information.....	27
Power Supply Configurations	6	Bill of Materials.....	27

REVISION HISTORY

10/2017—Rev. 0 to Rev. A

Changes EVAL-SDP-CBIZ to SDP-B.....	Throughout
Changes to General Description	1
Changes to Recommended Quick Start Guide.....	3
Changes to Device Description Section and Table 1	4
Changes to Serial Interface Power Section and Power Supplies Section and Table 2.....	5
Changes to Power Supply Configuration Section, Analog Inputs Section, Split Supply (Regulated) Section, Split Supply (Unregulated) Section and Reference Option Section	6
Added Figure 4 and Figure 5; Renumbered Sequentially	7
Changes to Software Installation Section and Figure 6.....	7
Changed Installing the Eval+ Dependency Drivers Section to Installing the Eval+ Dependencies Section.....	8
Added Figure 7 Through Figure 10	8
Changes to Launching the Software Section and Figure 12	9
Added Setting up the System for Data Capture Section, Figure 13, and Figure 14.....	9
Changes to Figure 15.....	10
Added Figure 16.....	10

Changes to Overview of the Main Window Section and Configuration Tab Section	11
Changed Analog Supply Voltage (6 and 8) Section to Analog and Digital Supply Voltage (6, 7, and 8) Section	11
Changes to Waveform Tab Section and Figure 17	12
Changes to Histogram Tab Section and Figure 18.....	13
Added Figure 19 and Modelled Performance Tab Section	14
Added Figure 20	15
Added Figure 21	16
Changed Register Map Tab Section to Registers Tab Section ..	17
Changes to Figure 22 and Figure 22 Caption	17
Added Evaluation Board Schematics and Artwork Section	18
Added Bill of Materials Section and Table 4.....	27

8/2015—Revision 0: Initial Version

EVAL-AD7172-4SDZ QUICK START GUIDE

RECOMMENDED QUICK START GUIDE

Follow these steps to set up the board:

1. Disconnect the **SDP-B** board from the USB port of the PC. Install the software AD717x Eval+ from the enclosed CD. After the AD717x Eval+ installs, the AD717x Eval+ dependencies installer runs and installs the required drivers. Restart the PC after installation.
2. Connect the **SDP-B** board to the **EVAL-AD7172-4SDZ** board, as shown in Figure 2.
3. Fasten the two boards with the enclosed plastic screw washer set.
4. Connect the external 9 V power supply to the J5 connector of the evaluation board, as shown in Figure 2. Set LK2 to Position B.
5. Connect the **SDP-B** to the PC via the USB cable. For Windows® XP, the user may need to search for the **SDP-B** drivers.
6. Choose to automatically search for the drivers for the **SDP-B** board if prompted by the Windows operating system.
7. Launch the AD717x Eval+ software from the Analog Devices subfolder in the **Programs** menu.

QUICK START NOISE TEST

Use the following procedure to test the noise performance:

1. Insert Link LK8 to Link LK16 to initiate the noise performance test mode. In this mode, analog input channels short to V_{CM} , which is equal to 2.5 V.
2. Click **Sample** to acquire samples from the ADC (see Figure 15).

The **Samples** numeric control in the top right corner of the main window sets the number of samples collected in each batch (see Figure 15).

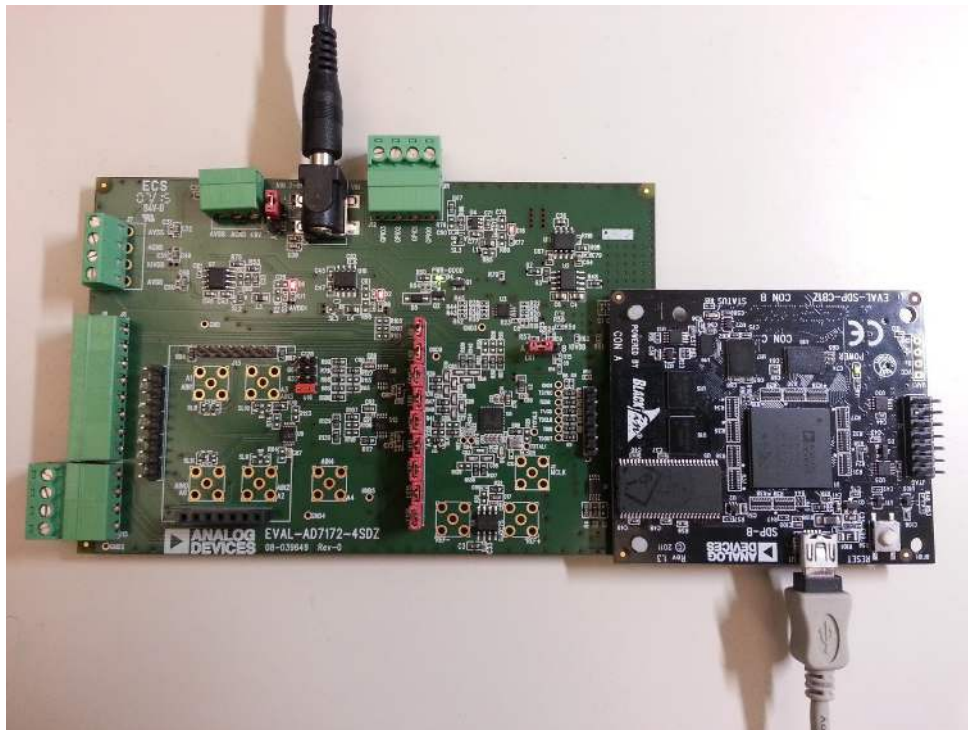

Figure 2. Hardware Configuration, Setting Up the **EVAL-AD7172-4SDZ**

EVALUATION BOARD HARDWARE

DEVICE DESCRIPTION

The [AD7172-4](#) is a highly accurate, high resolution, multiplexed, 4-/8-channel (fully differential/single-ended) Σ - Δ ADC. The [AD7172-4](#) has a maximum channel to channel scan rate of 6.21 kSPS (161 μ s) for fully settled data. The output data rates range from 1.25 SPS to 31.25 kSPS. The device includes integrated rail-to-rail analog input and reference input buffers, and an integrated oscillator.

See the [AD7172-4](#) data sheet for complete specifications. Consult the data sheet in conjunction with this user guide when using the evaluation board. Full details for the [SDP-B](#) are available on the Analog Devices website.

HARDWARE LINK OPTIONS

See Table 1 for default link options. By default, the evaluation board is configured to operate from the supplied 9 V ac to dc adapter connected to the J5 connector. The 5 V supply required for the [AD7172-4](#) comes from the on-board low dropout (LDO) regulator. The [ADP7118](#), with a 5 V output voltage, receives its input voltage from the J3 connector or the J5 connector (depending on the position of LK2) and generates a 5 V output.

Table 1. Default Link and Solder Link Options

Link	Default Option	Description
LK1	A	Selects the voltage applied to the power supply sequencer circuit (U3); dependent on AVDD1. Place in Position A if using 5 V AVDD1, or Position B if using 2.5 V AVDD1 and – 2.5 V AVSS.
LK2	B	Selects the external power supply from Connector J3 (Position A) or Connector J5 (Position B).
LK3 to LK7	Not inserted	Inserting these links sets up the on-board noise test prior to SL8 to SL11 to allow the inputs to the on-board amplifiers, U8 and U9, to be shorted. In this mode, all inputs short to V_{CM} , which is equal to 2.5 V.
LK8 to LK16	Inserted	Inserting these links sets up the on-board noise test close to the ADC analog inputs. In this mode, all inputs short to V_{CM} , which is equal to 2.5 V.
SL1	A	Selects the voltage applied to the AVDD2 pin. SL1 is positioned on the bottom side of the board. Position A is located at the lower end of SL1 and Position B is at the upper end. Position A selects AVDD1 (default). Position B selects an external 3.3 V supply from the ADP7118 (3.3 V) (U10) regulator.
SL2	A	Selects between an external or on-board AVDD1 source. Position A selects the on-board supply for AVDD1 set from the ADP7118 (5 V) (U7) (default). Position B selects the external supply voltage connected to J7, Pin 4.
SL3	A	Selects between an external or on-board AVSS source. Position A selects the on-board supply for AVSS from the ADP7182 (–2.5 V) (U4) (default). Position B selects the external supply voltage connected to J7, Pin 1.
SL4	C	Connects AIN8 to Pin 6 on J6 (Position A); V_{CM} , which is equal to 2.5 V (Position B); or AVSS (Position C). Position B and Position C are used to simplify the use of a single-ended input source.
SL5	B	Selects between an external or on-board IOVDD source. Position B selects the on-board supply for IOVDD from the ADP7118 (3.3 V) (U10) (default). Position B selects the external supply voltage connected to J7, Pin 3. The evaluation board operates with a 3.3 V logic.
SL8	A	Routes A1 input to the AIN5 pin on the AD7172-4 (Position A), Buffer/In-Amp U8 (Position B), Funnel Amp U9 with gain of 0.8 \times (Position C), or J10-1 (Position D).
SL9	A	Routes A2 to the AIN6 pin on the AD7172-4 (Position A), Buffer U12 (Position B), or Funnel Amp U9 gain of 0.4 \times (Position C).
SL10	A	Routes A3 to the AIN7 pin on the AD7172-4 (Position A), Buffer U12 (Position B), or Funnel Amp U9 gain of 0.4 \times (Position C).
SL11	A	Routes A0 to the AIN4 pin on the AD7172-4 (Position A), Buffer/In-Amp U8 (Position B), Funnel Amp U9 with gain of 0.8 \times (Position C), or J10-7 (Position D).
G16	Inserted	Sets the on-board U8 in-amp to a gain of 16. Insert only one of G16, G32, G64, or G128 at a time.
G32	Not Inserted	Sets the on-board U8 in-amp to a gain of 32. Insert only one of G16, G32, G64, or G128 at a time.
G64	Not Inserted	Sets the on-board U8 in-amp to a gain of 64. Insert only one of G16, G32, G64, or G128 at a time.
G128	Not Inserted	Sets the on-board U8 in-amp to a gain of 128. Insert only one of G16, G32, G64, or G128 at a time.
R49 to R51	Inserted	Connects AVSS and AGND for single-supply operation. To operate in split supply mode, remove these links.

SOCKETS AND CONNECTORS

Table 2. Connector Details

Connector	Function	Connector Type	Manufacturer	Manufacturer Number	Order Code ¹
J1	Connector to the SDP-B	120-way connector, 0.6 mm pitch	Hirose	FX8-120S-SV(21)	FEC1324660
J2	External MCLK input	Straight PCB mount SMB/SMA jack	TE Connectivity	1-1337482-0	Not applicable
J3	External bench top voltage supply for the EVAL-AD7172-4SDZ	Power socket block, 3-pin, 3.81 mm pitch	Phoenix Contact	MC 1,5/ 3-G-3,81	FEC3704737
J5	External ac to dc adapter input for the EVAL-AD7172-4SDZ , 7 V to 9 V	DC power connectors, 2 mm SMT power jack	Kycon	KLDX-SMT2-0202-A	MOUSER 806-KLDX-SMT20202A
J6	Analog input terminal block; wired connection to external source or sensor	Power socket block, 8-pin, 3.81 mm pitch	Phoenix Contact	MC 1,5/ 8-G-3,81	FEC3704774
J9	External bench top voltage supply option for AVDD1/AVDD2, IOVDD, and AVSS inputs on the AD7172-4	Screw terminal block, 3.81 mm pitch	Phoenix Contact	MKDS 1/4-3.81	FEC3704592
J10	Optional header	7-way, 2.54 mm pin header	Samtec	SSW-107-01-T-S	FEC1803478
J13	Optional header	7-way, 2.54 mm socket	Samtec	TLW-107-05-G-S	FEC1668499
A0 to A4	Analog inputs to ADC	Straight PCB mount SMB/SMA jack	TE Connectivity	1-1337482-0	Not applicable
A7	Pmod™-compatible header	6-pin single inline header (0.1 inch pitch)	Harwin	20-9990646	FEC 1022255

¹ Order codes starting with FEC are for Farnell.

SERIAL INTERFACE

The [EVAL-AD7172-4SDZ](#) evaluation board connects via the serial peripheral interface (SPI) to the Blackfin® [ADSP-BF527](#) on the [SDP-B](#). There are four input signals: \overline{CS} , \overline{SCLK} , \overline{DIN} , and \overline{SYNC} , and one output signal from the ADC, $\overline{DOUT/RDY}$ (see Figure 1).

To operate the evaluation board in standalone mode, disconnect the evaluation board from the [SDP-B](#) controller board. Use the test points labeled on the evaluation board to connect the signals to an alternative digital capture setup or the Pmod-compatible header (A7).

POWER SUPPLIES

Power the evaluation board from the ac to dc adapter connected to J5, or from an external bench top supply applied to J3 or J9. Linear LDO regulators generate the required voltages from the applied input voltage (V_{IN}) rail when using J3 or J5. Use J9 to bypass the on-board regulators. An [ADP7118](#) regulator generates the 5 V (single-supply) and 2.5 V (split supply) supplies for the AVDD1 and AVDD2 rails to the ADC; a second [ADP7118](#) generates 3.3 V for the IOVDD rail. The [ADP7104](#) supplies 5 V for the [SDP-B](#) controller board as well as 5 V for the [ADM660](#) voltage converter to generate –5 V to supply the [ADP7182](#). The [ADP7182](#) generates the –2.5 V supply for AVSS when operating in split supply mode. Each supply is decoupled where it enters the board and again at each device (evaluation board files, including schematics and bill of materials, are available for download at <http://www.analog.com/EVAL-AD7172-4>).

Table 3 shows the various power supply configurations available, including split supply operation.

Table 3. Power Supply Configurations¹

Configuration	Input Voltage Range	Description
Single Supply (Regulated)	7 V to 9 V	The 7 V to 9 V input is regulated to 5 V for AVDD1/AVDD2 and 3.3 V for IOVDD. This also powers the external 5 V reference. See the Single-Supply (Regulated) section.
Single Supply (Unregulated)	7 V to 9 V, 5 V, and 3.3 V	The input is unregulated and connects directly to AVDD1/AVDD2 and IOVDD from J5. The 7 V to 9 V input powers the external 5 V reference. See the Single Supply (Unregulated) section.
Split Supply (Regulated)	7 V to 9 V	The 7 V to 9 V input is regulated to 2.5 V for AVDD1/AVDD2, -2.5 V for AVSS and 3.3 V for IOVDD. The 7 V to 9 V input powers the external 5 V reference. See the Split Supply (Regulated) section.
Split Supply (Unregulated)	7 V to 9 V, ±2.5 V, and 3.3 V	The input is unregulated and connects directly to AVDD1/AVDD2 and IOVDD from J5. The 7 V to 9 V input powers the external 5 V reference. See the Split Supply (Unregulated) section.

¹ Only one configuration can be used at a time.

POWER SUPPLY CONFIGURATIONS

Single-Supply (Regulated)

There are two available power supply options for the single supply (regulated) configuration.

- Connect the ac to dc adapter (included) to J5 and set LK2 to Position B or Connect the bench top power supply to J3, set LK2 to Position A, and ensure that AVSS = AGND = 0 V.
- Set all other links and solder links to the default settings as outlined in Table 1.

Single Supply (Unregulated)

To set up the board, use the following procedure:

1. Move SL2 to Position B and SL5 to Position A.
2. Connect the two terminals of J9 (AGND and AVSS).
3. Connect the 0 V input (GND) to J9 at the AGND terminal.
4. Connect the 5 V input to J9 at the AVDD terminal.
5. Connect the 3.3 V input to J9 at the IOVDD terminal.
6. Connect the 7 V to 9 V input to J5.

Set all other links and solder links to the default settings as outlined in Table 1.

Split Supply (Regulated)

To set up the board, use the following procedure:

1. Remove R49 to R51. These links connect AVSS to AGND.
2. Insert a 0 Ω resistor at R67 and R85.
3. Set LK1 to Position B, which sets the input to the power monitor circuitry to work with the lower AVDD1 supply of 2.5 V.
4. Connect the 7 V to 9 V input to J5 and set LK2 to Position B.

Set all other links and solder links to the default settings as outlined in Table 1.

Split Supply (Unregulated)

To set up the board, use the following procedure:

1. Move SL2 and SL3 to Position B, and SL5 to Position A.
2. Remove R49 to R51.
3. Insert a 0 Ω resistor at R67 and R85.
4. Connect the 0 V input (GND) to J9 at the AGND terminal.
5. Connect the 2.5 V input to J9 at the AVDD terminal.
6. Connect the -2.5 V input to J9 at the AVSS terminal.
7. Connect the 3.3 V input to J9 at the IOVDD terminal.
8. Set LK1 to Position B, which sets the input to the power monitor circuitry to work with the lower AVDD1 supply of 2.5 V.
9. Connect the 7 V to 9 V input to J5.

Set all other links and solder links to the default settings as outlined in Table 1.

ANALOG INPUTS

The primary analog inputs of the [EVAL-AD7172-4SDZ](#) evaluation board can be applied in two separate ways.

- At the J6 connector on the left side of the board
- At the A0 to A4 SMB/SMA footprints on the evaluation board

The analog inputs route directly to the associated analog input pins on the [AD7172-4](#) provided that the LK3 to LK16 links are removed. The AD717x Eval+ software is set up to analyze dc inputs to the ADC. The [AD7172-4](#) input buffers work for dc input signals.

REFERENCE OPTIONS

The [EVAL-AD7172-4SDZ](#) includes an external 5 V reference, the [ADR445](#). This reference connects to the REF+ input, and the REF- input is connected to AVSS. The [AD7172-4](#) has a second reference input, AIN0/REF2- and AIN1/REF2+. There are also two SMB/SMA footprints for connecting an external voltage reference source in place of the [ADR445](#).

EVALUATION BOARD SOFTWARE

SOFTWARE INSTALLATION

The EVAL-AD7172-4SDZ evaluation kit includes software on a CD. Double click the **setup.exe** file from the CD to run the installer. The default installation location for the software is **C:\Program Files\Analog Devices\AD7172-4 Eval+**.

Install the AD717x Eval+ software before connecting the evaluation board and the SDP-B to the USB port of the PC to ensure that the evaluation system is correctly recognized when connected to the PC.

There are two parts to the installation.

1. AD717x Eval+ software installation.
2. AD717x Eval+ Dependencies
 - a) SDP-B board drivers
 - b) Srcr SVG plug in

Warning

To ensure the PC correctly recognized the evaluation system, the evaluation software drivers must be installed before connecting the EVAL-AD7172-4SDZ evaluation board and SDP-B boards to the USB port of the PC.

Installing the AD717x Eval+ Software

To install the AD717x Eval+ software, take the following steps:

1. With the SDP-B board disconnected from the USB port of the PC, insert the CD into the CD-ROM drive.
2. Double click the **setup.exe** file from to begin the evaluation board software installation. The default installation location for the software is **C:\Program Files\Analog Devices\AD7172-4 Eval+**.
3. A dialogue box appears asking for permission to allow the program to make changes to the PC (See Figure 3). Click **yes**.

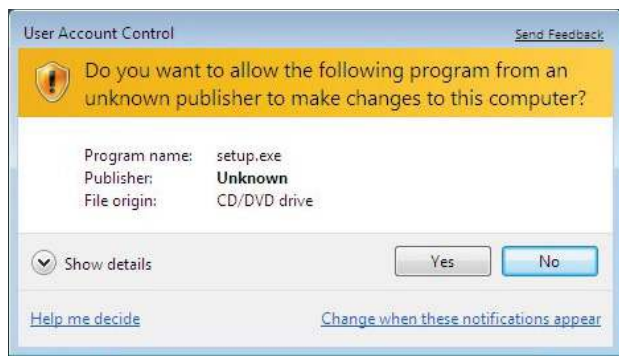

Figure 3. AD7172-4 User Account Control Permission Dialog Box

4. Select a location to install the software and click **Next**. Figure 4 shows the default locations displayed when the dialogue box opens. To select another location click **Browse**.

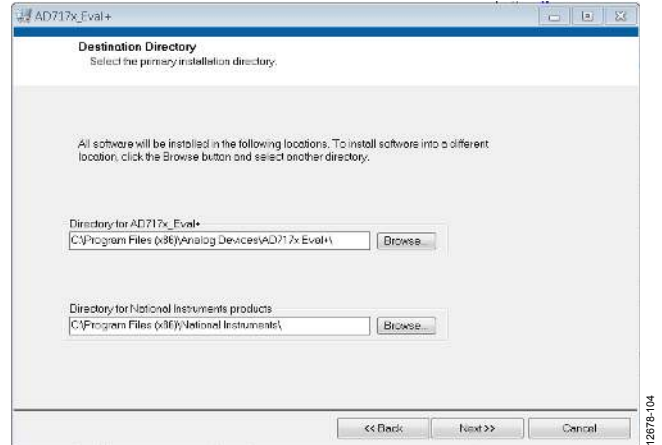

Figure 4. AD717x Eval+ Installation Selecting the Location for Software Installation

5. A license agreement appears. Read the agreement, select **I accept the License Agreement**, and click **Next**.

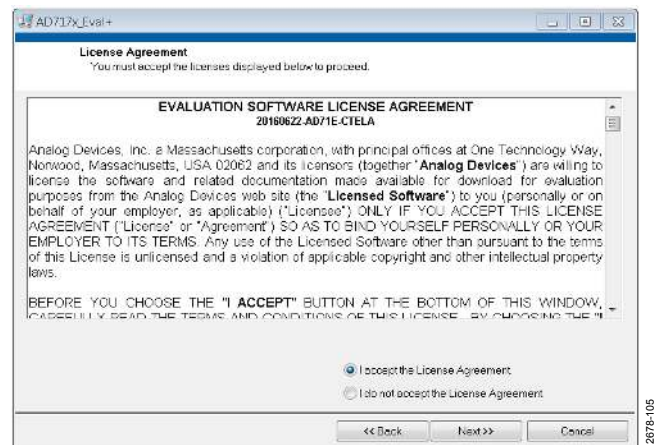

Figure 5. AD717x Eval+ Installation Accepting the License Agreement

6. A summary of the installation displays. Click **Next** to continue.

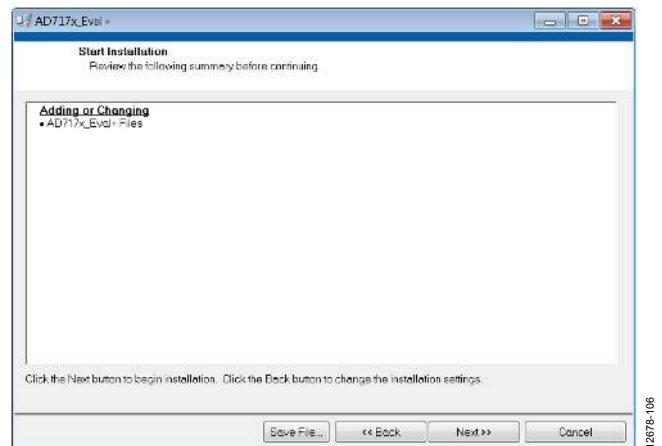

Figure 6. AD717x Eval+ Installation Reviewing a Summary of the Installation

- The message in Figure 7 appears when the installation is complete.

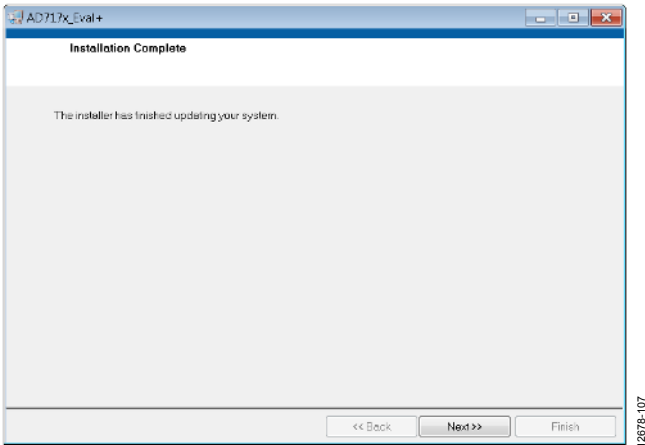

Figure 7. AD717x Eval+ Installation Complete

Installing the Eval+ Dependencies

After the installation of the evaluation software is complete, a welcome window displays to install the **Eval+ Dependencies**.

- With the **SDP-B** board still disconnected from the USB port of the PC, make sure all other applications are closed, and then click **Install**.

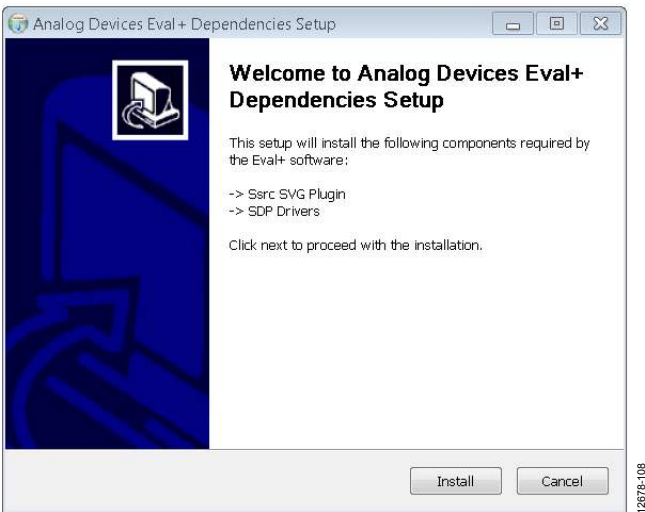

Figure 8. Eval+ Dependencies Setup Beginning the Drivers Installation

- To complete the drivers installation, click **Close**. This closes the installation setup wizard

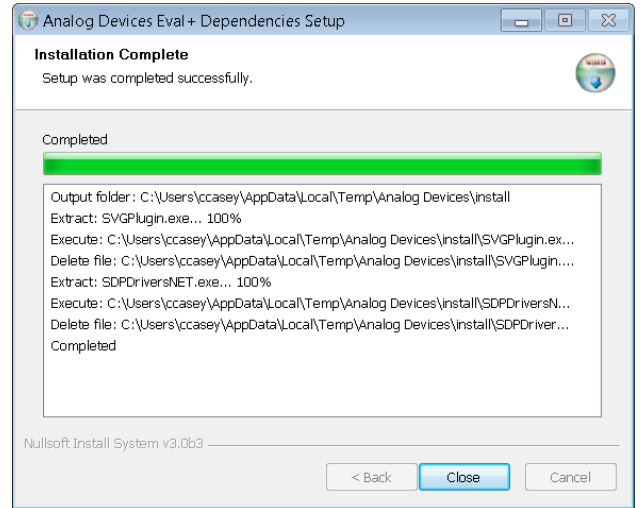

Figure 9. Eval+ Dependencies Setup Completing the Drivers Setup Wizard

- Before using the evaluation board, you must restart the PC.



Figure 10. Restarting the PC

SETTING UP THE SYSTEM FOR DATA CAPTURE

After completing the steps in the Software Installation section and the Evaluation Board Hardware section, set up the system for data capture using the following:

1. Allow the **Found New Hardware Wizard** to run after the **SDP-B** board is connected to the PC. (If using Windows XP, search for the **SDP-B** drivers, Choose to automatically search for the drivers if prompted by the operating system.)
2. Check that the board is connecting to the PC correctly using the **Device Manager**.
3. Access the **Device Manager** by completing the following steps:
 - a) Right-click **My Computer** and then click **Manage**.
 - b) A dialog box appears asking for permission to allow the program to make changes to the PC. Click **Yes**.
 - c) The **Computer Management** box appears. Click **Device Manager** from the list of **System Tools** (See Figure 11).
 - d) The **SDP-B** board appears under **ADI Development Tools**, this indicates that the driver software has installed and the board is connecting to the PC correctly.



Figure 11. Device Manager, Checking the Board Connected to the PC Correctly

Launching the Software

After completing the steps in the Setting Up the System for Data Capture section, launch the AD717x Eval+ software using the following steps:

1. From the **Start** menu, click **Programs > Analog Devices > AD717x EVAL+ > AD717x Eval+**.
2. The dialogue box in Figure 12 appears; select **AD7172-4 Evaluation Board**. The main window of the software box displays as shown in Figure 15.

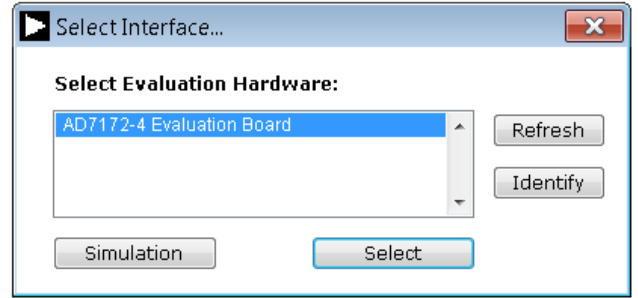

Figure 12. AD717x Evaluation Board Selection

3. If the **EVAL-AD7172-4SDZ** evaluation system is not connected to the USB port via the **SDP-B** when the software is launched, the software displays the dialog box shown in Figure 13. Connect the evaluation board to the USB port of the PC; wait a few seconds, click **Refresh** and the option shown in Figure 12 appears.

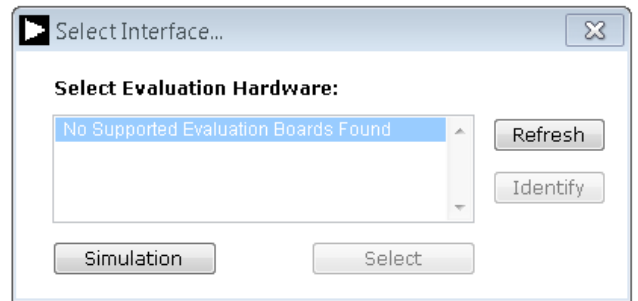

Figure 13. Evaluation Board Selection, No Board Connected

4. The AD717x Eval+ can also be used without connecting hardware. Click the **Simulation** button and the options shown in Figure 14 appear. This uses a software model and allows the **AD7172-2**, **AD7172-4**, **AD7173-8**, **AD7175-2**, **AD7175-8**, **AD7176-2** or **AD7177-2** to be evaluated.

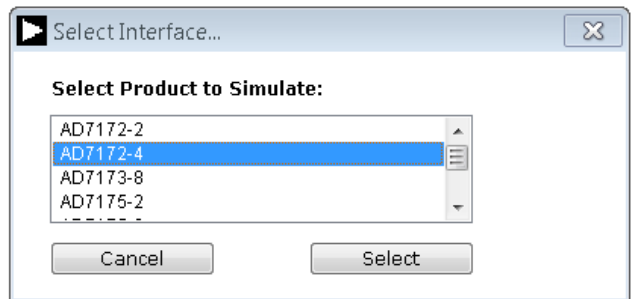

Figure 14. Evaluation Board Selection Simulation

OVERVIEW OF THE MAIN WINDOW

The main window of the AD717x Eval+ software displays the significant control buttons and analysis indicators of the AD717x Eval+ software. This window is divided into five tabs.

- Configuration
- Waveform
- Histogram
- Modelled Performance
- Registers

CONFIGURATION TAB (1)

Figure 15 shows the **Configuration** tab when **Hardware** mode is selected and Figure 16 shows the **Configuration** tab when **Simulation** mode is selected. The controls highlighted in Figure 16 are only available in **Simulation** mode.

Select Product/Evaluation Mode (2)

The Evaluation Mode indicator displays the current evaluation mode. To switch between modes, click the **Select Product** button and the dialog box shown in Figure 12 appears.

Tutorial Button (3)

Click the tutorial button to open a tutorial and additional information on using the AD717x Eval + software.

Functional Block Diagram (4)

The functional block diagram of the ADC shows each of the separate functional blocks within the ADC. Clicking a **Configuration** button on any of the functional blocks opens the configuration pop-up window for the block selected. Not all blocks have a configuration button.

Configuration Pop-Up Button (5)

Each configuration pop-up button opens a different window that allows the configuration of the relevant functional block.

Analog and Digital Supply Voltage (6, 7, and 8)

These input fields are used to take the supply voltage levels selected for the AD7172. Checks are performed to ensure that the power supply voltage levels entered are within the specified limits. These power supply voltage levels are also used for the modelled performance to calculate the power dissipation.

External Reference (Ext. REF) (9)

The **Ext. REF** input fields set the positive and negative external reference voltage values. The difference is used in calculating the results for both the **Waveform** and **Histogram** tabs. The evaluation board has an external 5 V ADR445 reference, this can be bypassed by removing R32. Change the external reference voltage value in **Ext. REF** to ensure correct calculation of results in the **Waveform** and **Histogram** tabs.

External MCLK Frequency (10)

This field sets the external MCLK frequency. It is only visible on the front panel when an external clock source is selected by the ADC. It is used by the functional model for **Modelled Performance** (31).

Register Configuration Summary (11)

Click the **Summary** button to display the selected configuration of the AD7172-4, this includes channel configuration, information on each of the individual setups, as well as, information on any error present.

Reset ADC (12)

Click the **Reset ADC** button to perform a software reset of the AD7172-4. The AD7172-4 does not have a hardware reset pin, to perform a hard reset the power must be removed from the board. The software reset has the same effect as a hard reset.

Menu Bar (13)

The menu bar has three sections: **File**, **Edit**, and **Help**.

File

There are three options available in the File Menu. Save, Load, and Generate.

Save

Save allows the user to save register configurations or waveform data. Register configurations can be saved as a JSON file or a header file. If the configuration is only used in the AD717x Eval+ software environment then it is recommended to use the JSON setting. Waveforms are saved as .csv files and the user is prompted to save the register configuration as well.

Load

Load allows the user to load saved register configurations or waveform data. In order to load a header file into AD717x Eval+ it must be in the same format as one that is saved from AD717x Eval+. The header file can be used when developing firmware. When loading the waveform data the user is prompted to load the register configuration. This is so the software can correctly analyze the data.

Generate

Generate offers two options: No-OS Drivers and Communication drivers. No-OS drivers are used by a microcontroller to interact with the AD7172-4. The Communications drivers provide a template for SPI and I²C methods that are used with the No-OS drivers. The implementation of the communication is not included; this is what allows the driver to be used with any microcontroller. More information on these drivers can be found in the Help section.

Edit

There are two options available in the **Edit** dropdown menu, Change Product Selection and Reset ADC. Change Product Selection performs the same action as the **Select Product (2)** and Reset ADC performs the same action as the **Reset ADC (12)** controls.

Help

The Help dropdown menu provides links to extra information about the [AD7172-4](#), which includes links to the product page, evaluation board user guide, datasheet, and No-OS Drivers. Selecting the AD717x Eval+ Tutorial opens the tutorial outlined in the **Tutorial Button (3)**. For details on the version of the software the About option opens a dialog box displaying the current version of the software and the relevant licenses.

Status Bar (14)

The status bar displays the busy indicator and status updates, such as **Analysis Completed** and **Reset Completed** during software use.

Device Error (15)

The Device Error LED icon illuminates when a when an ADC error is detected or when a cyclic redundancy check (CRC) error occurs. The CRC functionality on the [AD7172-4](#) is disabled by default and must be enabled for this indicator to work. More specific information on the error can be found in the **Register Configuration Summary (11)**.

Analog Input Voltage (16)

These input fields are only available when the AD717x Eval+ software is executed in simulation mode. These inputs allow the analog input voltages to be set and can be changed at any time while in simulation mode.

External SCLK Frequency (17)

This input field sets the external SCLK frequency for the SPI interface. This field is only available in simulation mode to determine if the SCLK frequency is within the permitted range.

WAVEFORM TAB (18)

Figure 17 shows the **Waveform** tab of the AD717x Eval+ Software.

Sampling Mode (19)

This control is unrelated to the ADC mode. You can capture a defined sample set, single capture. Or continuously gather batches of samples, repeated capture. You can also select data logging that runs like repeated capture but posts the results to a .csv file. When saving, the .csv file prompts you to save the register configuration, this is necessary for the analysis of the data in order to load it back into the software.

Samples (20)

The Samples numeric control sets the number of samples gathered per batch. Single capture returns the number entered in the Samples control. Repeated capture keeps returning batches of the number in Samples until stopped by the user

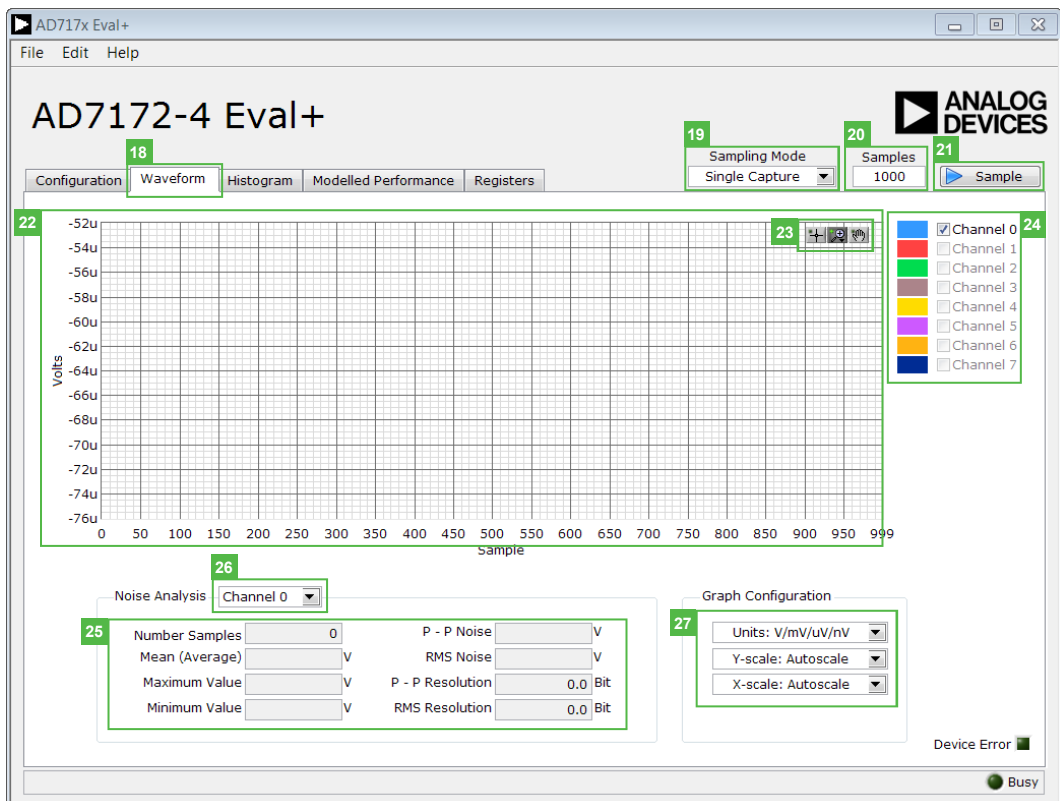

Figure 17. **Waveform** Tab of the [AD7172-4](#) Evaluation Software

Sample (21)

Click the **Sample** button to start gathering ADC results. Results appear in the waveform graph (22).

Waveform Graph and Controls (22 and 23)

The data waveform graph shows each successive sample of the ADC output. Zoom in on the data using the control toolbar (23). Click the x-axis and y-axis to change the scales on the graph.

Channel Selection (24)

The channel selection control allows you to choose which channels display on the data waveform graph (23). These controls only affect the display of the channels and do not have any effect on the channel settings in the ADC register map.

Noise Analysis (25)

The Noise Analysis section displays the results of the noise analysis for the selected analysis channel; this includes both noise and resolution measurements.

Analysis Channel (26)

The Noise Analysis section and histogram graph show the analysis of the channel selected via the Analysis Channel dropdown menu.

Display Units and Axis Controls (27)

Click the Units dropdown menu to select the unit the data displays in the graph. This control affects both the waveform graph and the histogram graph. The axis controls can be switched between dynamic and fixed. When dynamic is selected, the axis automatically adjusts to show the entire range of the ADC results after each batch of samples. When fixed is selected, the user can program the axis ranges; the axis ranges do not automatically adjust after each batch of samples.

HISTOGRAM TAB (18)

Figure 18 shows the **Histogram** tab of the AD717x Eval+ software.

Histogram Graph and Controls

The data histogram graph (20) shows the number of times each sample of the ADC output occurs. The control toolbar (21) in the histogram graph allows you to zoom in on the data (see Figure 18). Click the x-axis and y-axis to change the scales on the graph (see Figure 18).

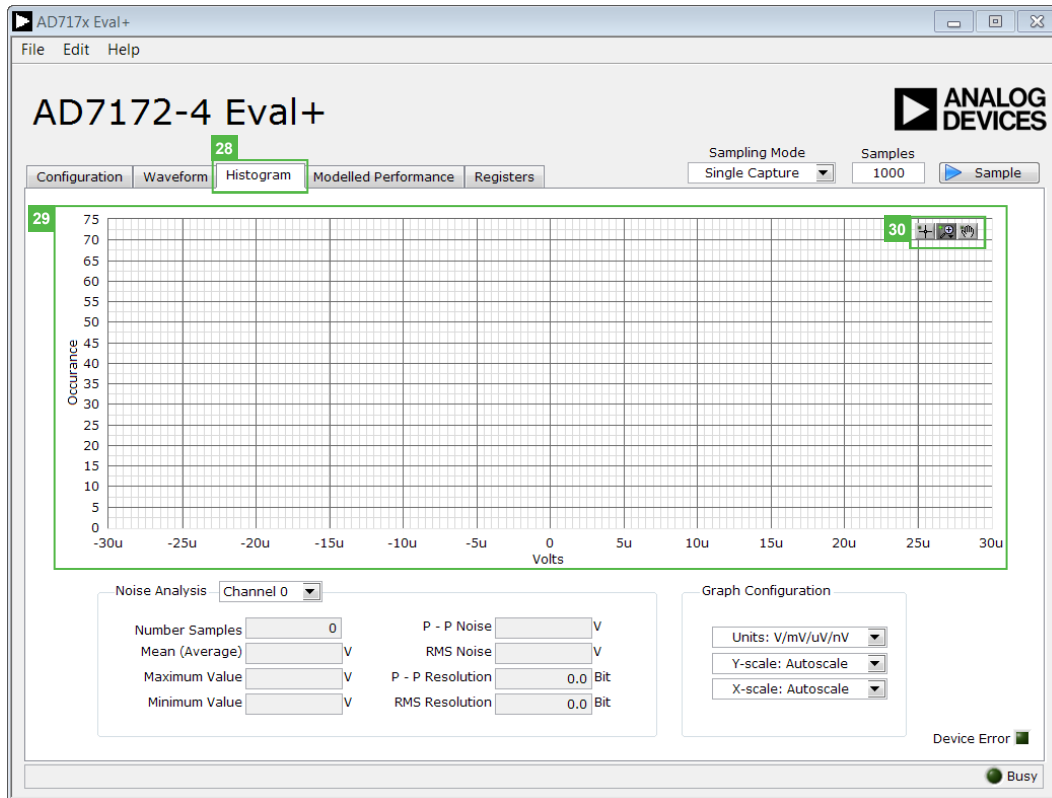

Figure 18. Histogram Tab of the AD7172-4 Evaluation Software

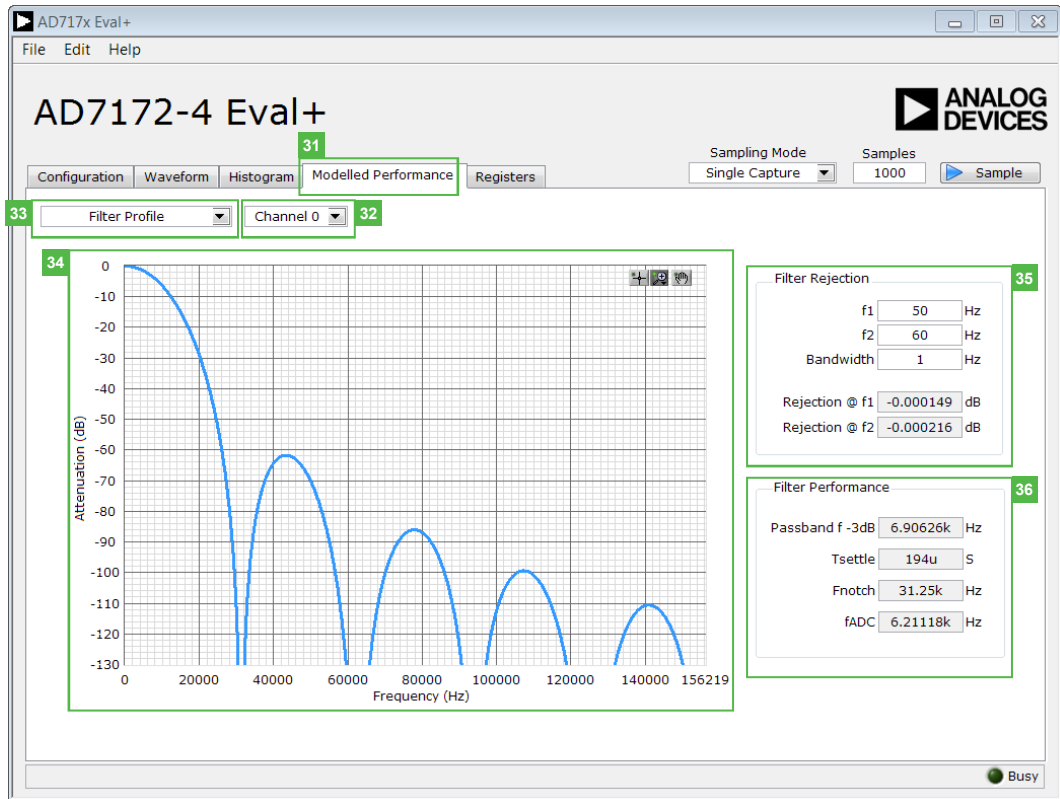

Figure 19. Filter Profiles of the AD7172-4 Evaluation Software

MODELLED PERFORMANCE TAB (31)

The **Modelled Performance** tab shows a number of ADC performance parameters, which are calculated using the ADC functional model. There are three main sections to the **Modelled Performance** tab: Filter Profile, Filter Step Response, and Timing Diagram/Power. These can be selected using the drop down menu (33).

Analysis Channel (32)

The Analysis Channel dropdown menu selects the channel to be evaluated by the functional model.

Filter Profile (33)

This drop down menu allows the user to switch between the three sections of the **Modelled Performance**. Figure 19 shows the tab when filter profile is selected.

Filter Profile Graph (34)

This graph shows the frequency response for the selected digital filter. The graph controls allow you to zoom in on the data. Click the x-axis and y-axis to change the scales on the graph.

Filter Rejection (35)

This section shows the rejection/attenuation of the digital filter over the rejection bandwidth (Rej BW) for f1 and f2 in decibels; f1, f2 and Bandwidth can be changed.

Filter Performance (36)

This section shows timing information about the data rate of the selected output. It shows the ADC initial settling time, Tsettle, the first frequency notch (Fnotch), and the actual sampling frequency (fADC).

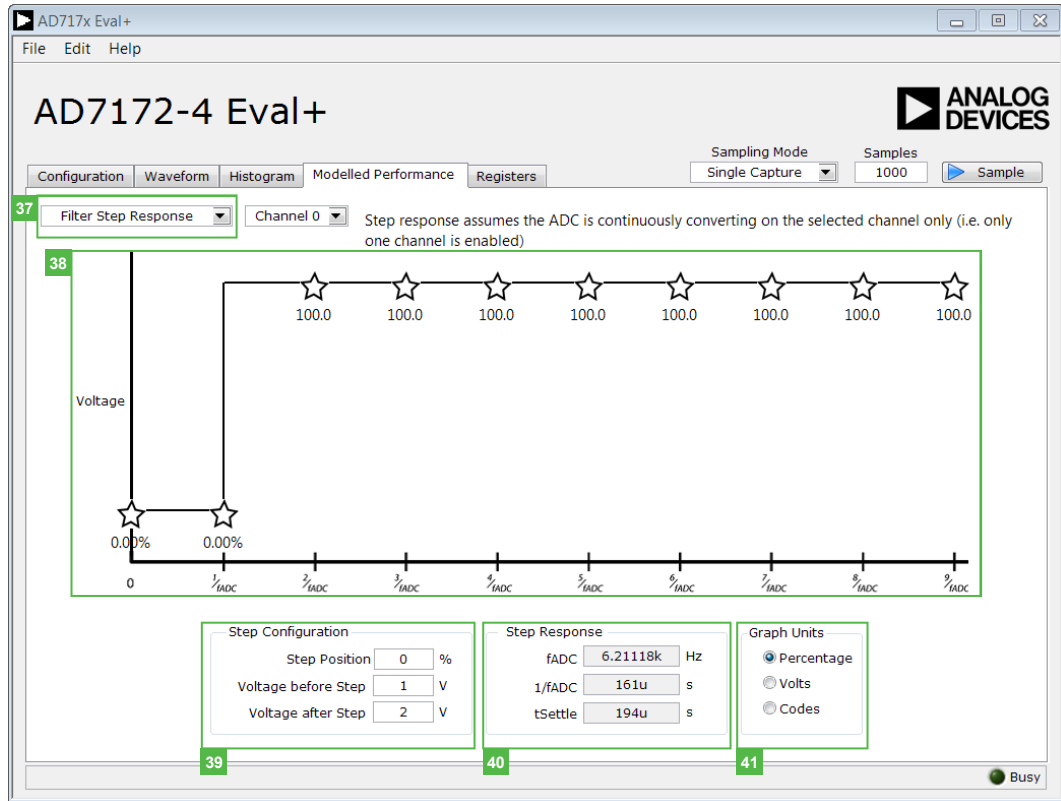

Figure 20. Filter Step Response of the AD7172-4 Evaluation Software

Filter Step Response (37)

This drop down menu allows the user to switch between the three sections of the **Modelled Performance** tab. Figure 20 shows the tab when Filter Step Response is selected.

Step Response Graph (38)

This graph shows how long the filter takes to settle when the voltage is stepped from one voltage to the next. For this analysis, it is assumed the ADC is continuously converting on only one channel.

Step Configuration (39)

Step Configuration allows the user to set the voltage before and after the step and the step position. Step position is set as a percentage where 0% is 1/fADC and 100% is 2/fADC.

Step Response (40)

This section shows timing information about the data rate of the output selected output. It shows the actual sampling frequency, fADC, the ADC initial settling time (Tsettle), and the settling time between conversions, 1/fADC.

Graph Units (41)

Use this control to switch the step response between percentages, volts, and codes.

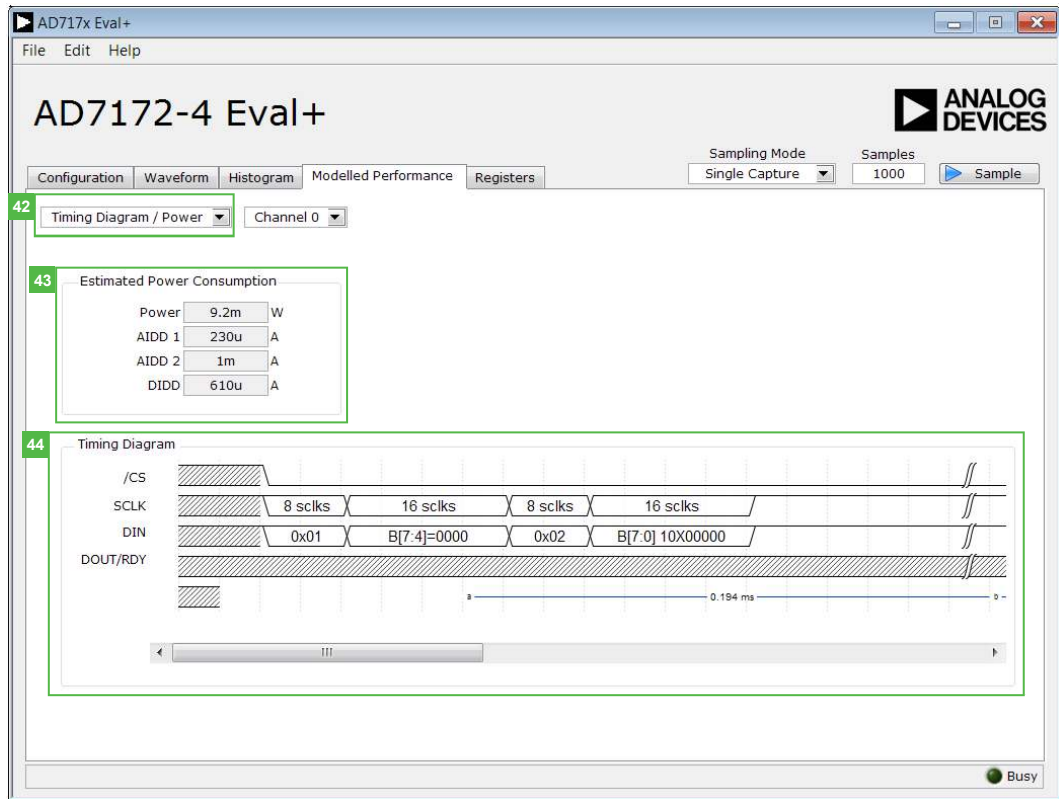

Figure 21. Timing Diagram/Power of the AD7172-4 Evaluation Software

Timing Diagram/ Power (42)

This drop down menu allows the user to switch between the three sections of the **Modelled Performance**. Figure 21 shows the tab when Filter Step Response is selected.

Estimated Power Consumption (43)

This section shows the total power consumption of the part in the current configuration as well as the current consumption on each of the power supply rails.

Timing Diagram (44)

This graph shows the digital interface timing diagram for the current configuration. The graph shows the timing for both the configuration of the ADC, and the subsequent data reads from the ADC.

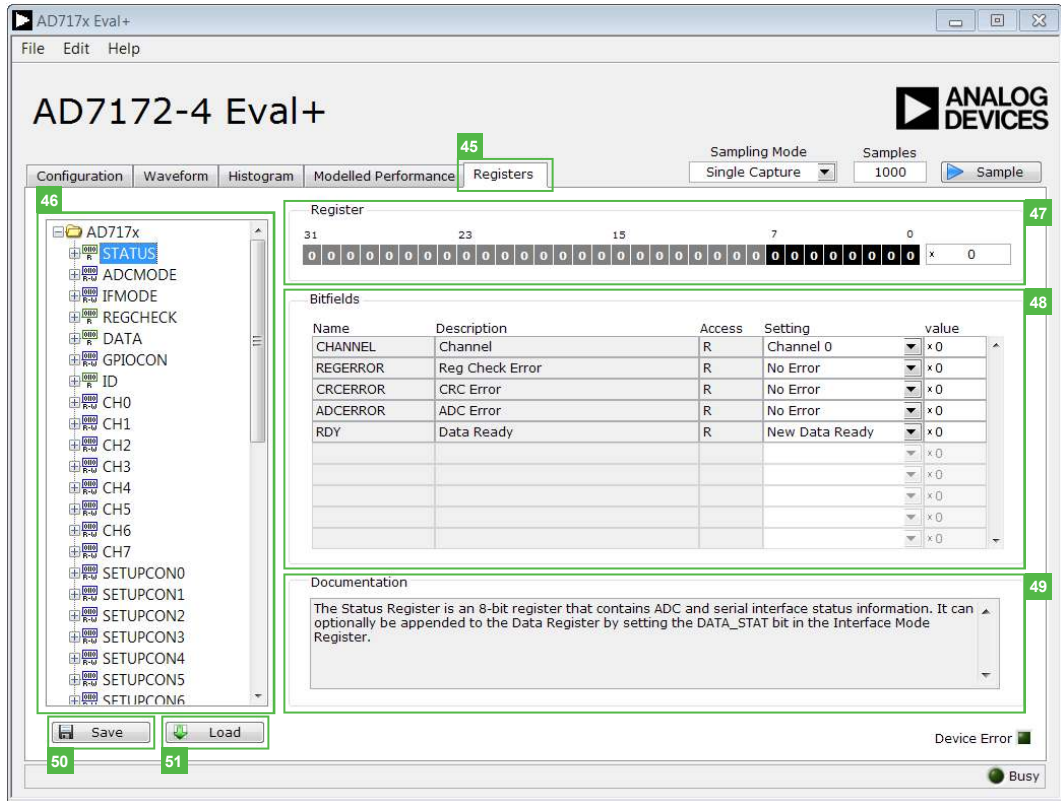

Figure 22. Registers Tab of the AD7172-4 Evaluation Software

REGISTERS TAB

Figure 22 shows the **Registers** tab.

Register Tree (46)

This control shows the full register map in a tree control. Each register is shown; click the expand button next to each register to show all the bit fields contained within that register.

Register (47)

The **Register** control allows you to change the individual bit of the register selected in the register tree (46) by clicking the bits, or by programming the register value directly into the number control field on the right.

Bitfields (48)

This list shows all the bit fields of the register selected in the register tree (46). Change the values by using the dropdown menu or by directly entering a value into the number control field on the right.

Documentation

The Documentation field contains the documentation for the register or bit field selected in the register tree (46).

Save (50) and Load (51)

The **Save** (50) and **Load** (51) buttons allow you to save the current register map setting to a file and load the setting from that same file. When using these buttons the register configurations are saved and loaded as JSON files.

EXITING THE SOFTWARE

To exit the software, click the close button at the top right corner of the AD717x Eval+ software.

EVALUATION BOARD SCHEMATICS AND ARTWORK

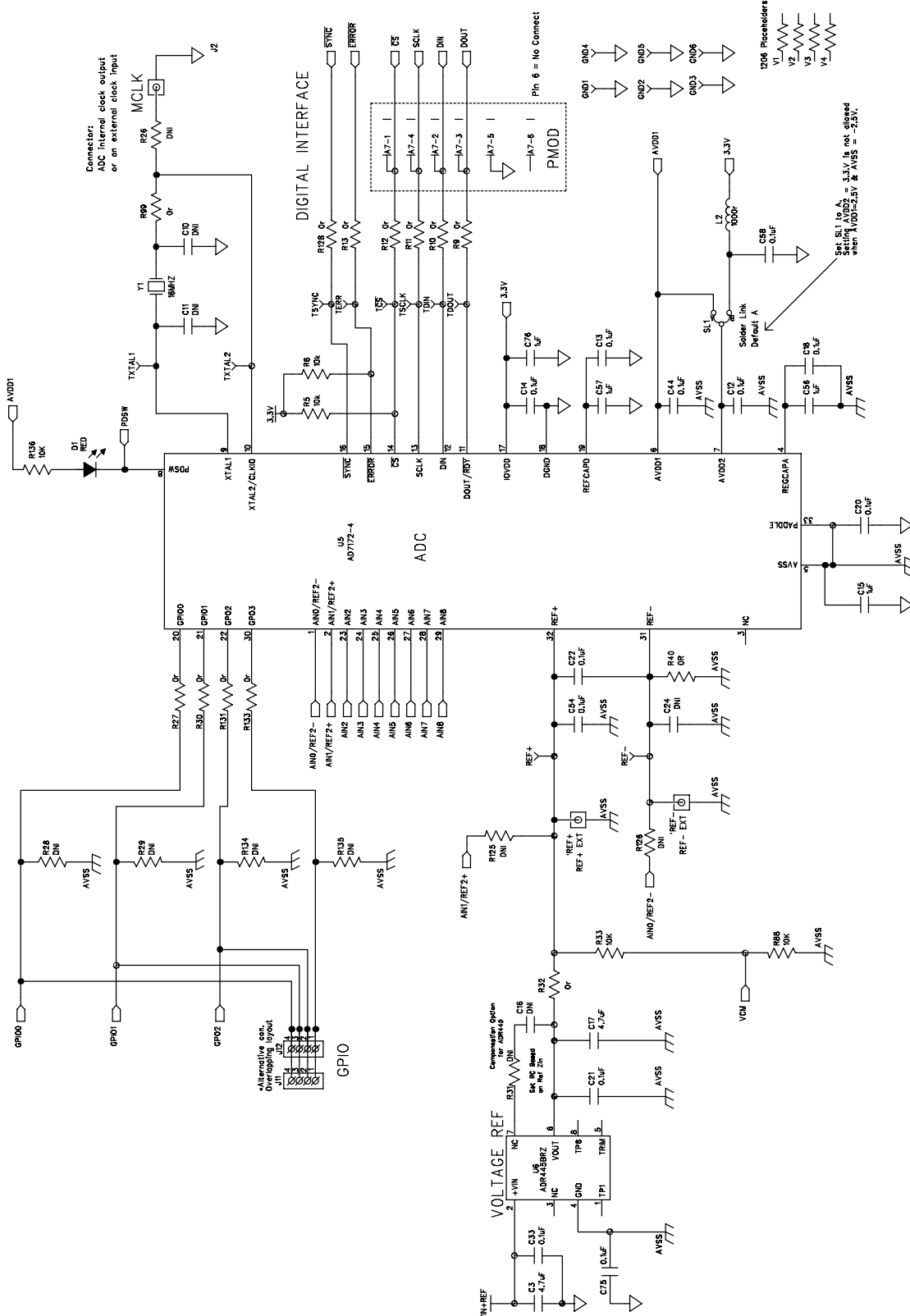

12678-123

Figure 23. AD7172-4 Schematic

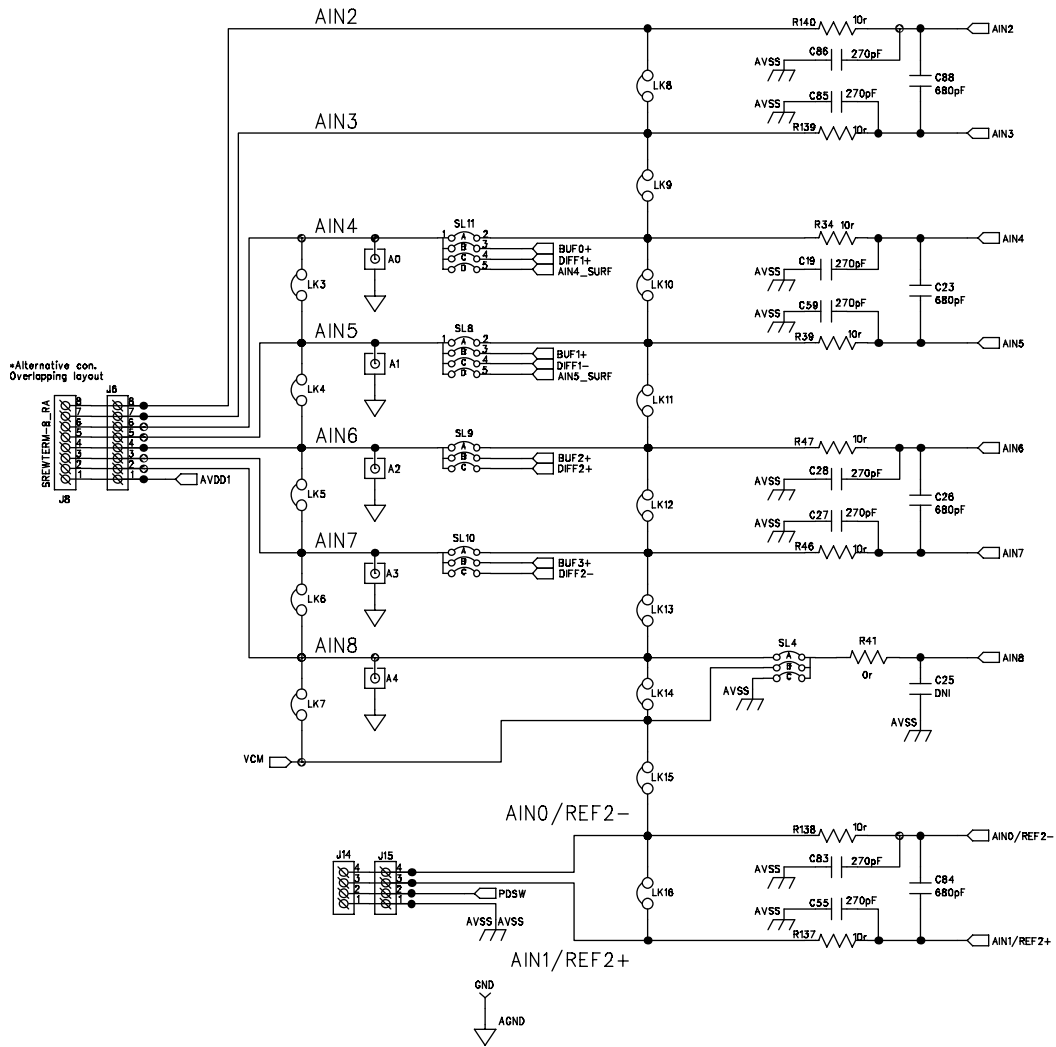

Figure 24. Input Schematic

12678-124

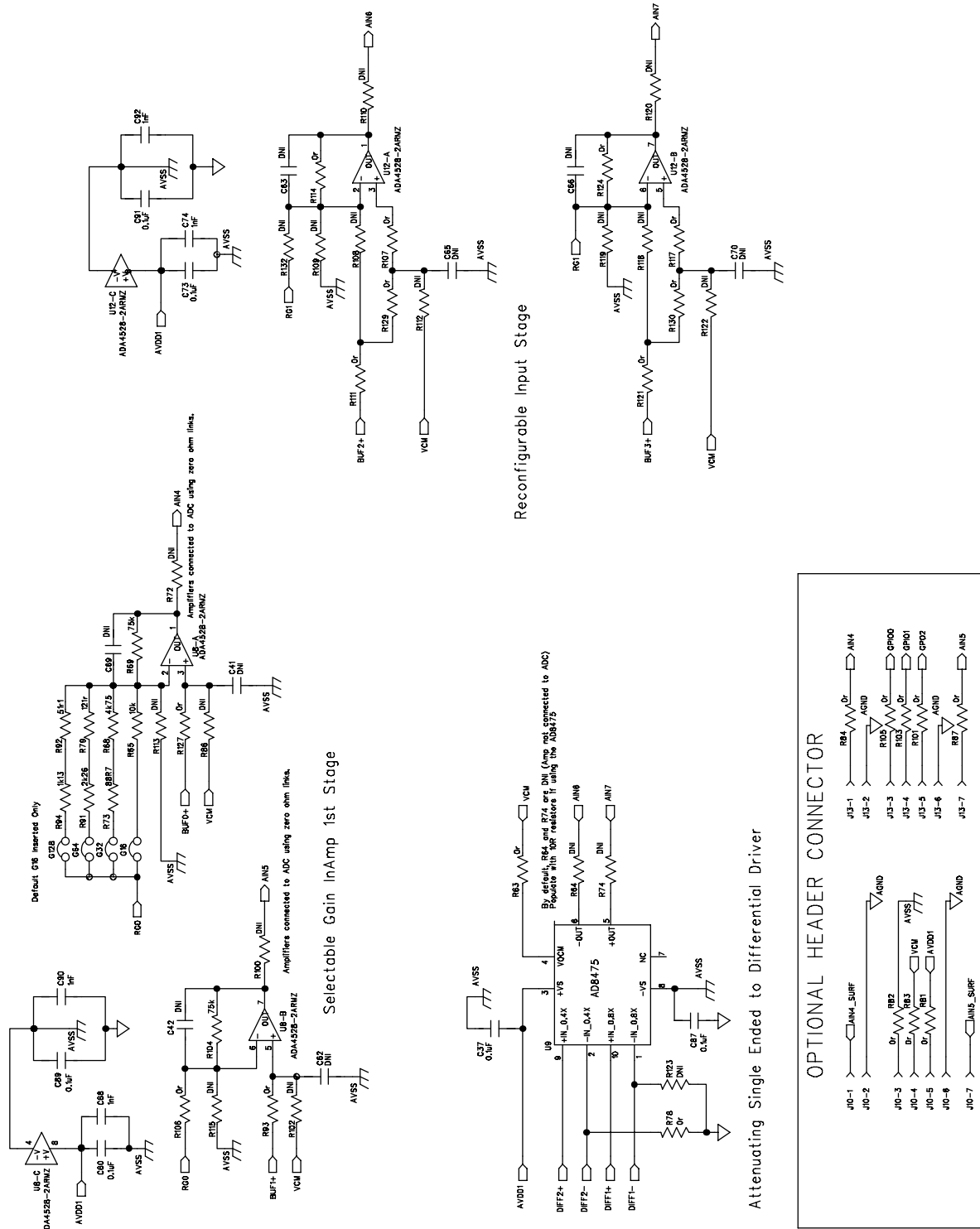

Figure 25. Amplifier Schematic

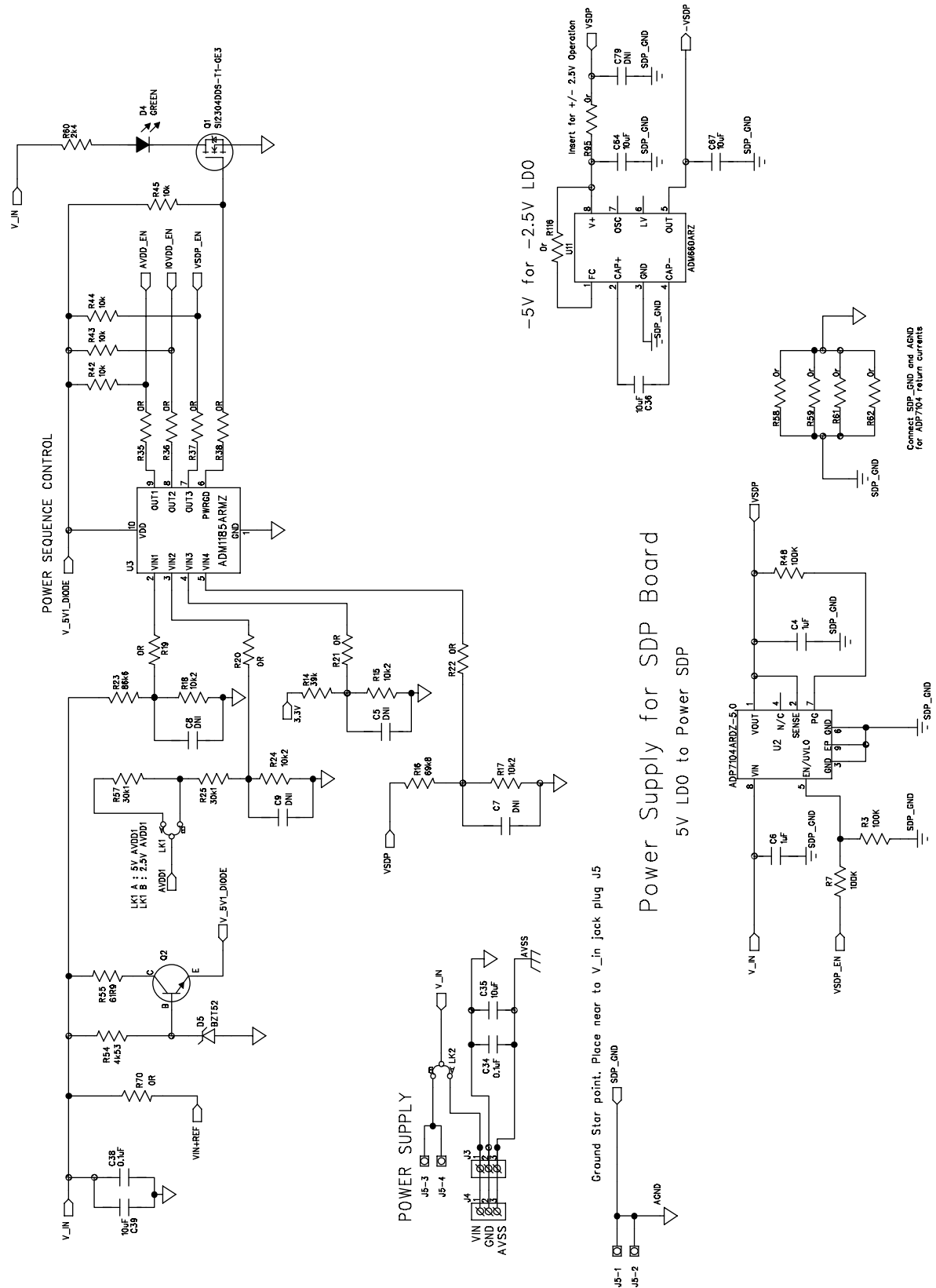

Figure 26. Power Supply Sequencing Schematic

5V, 3.3V & +/- 2.5V Regulators

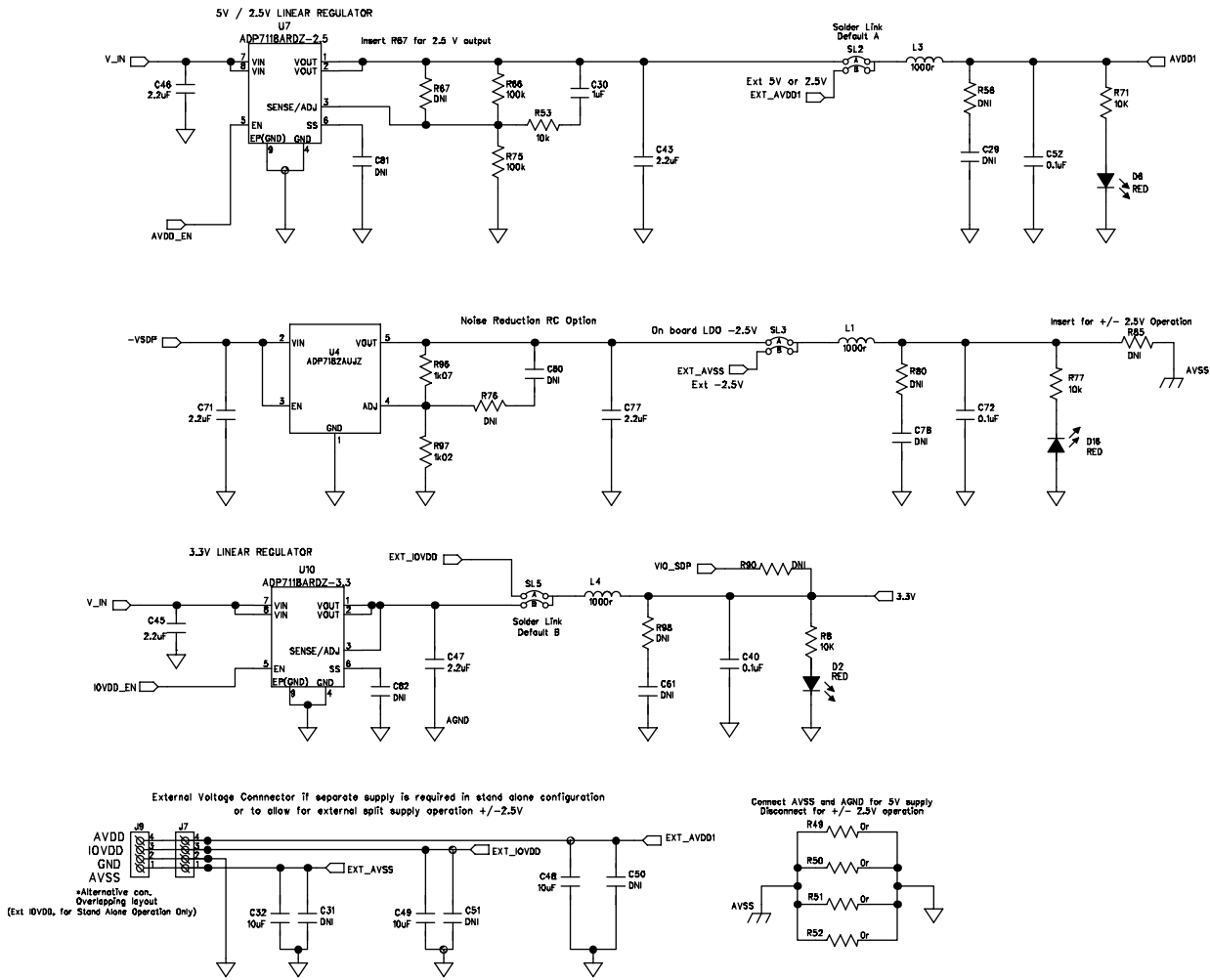

Figure 27. Regulator Schematic

12676-127

SDP CONNECTOR EEPROM-SW/USB ID

VIO: USE to set IO voltage max draw 20mA
 VIN: Use this pin to power the SDP requires 4-7V 200mA
 BMODE: Pull up with a 10K resistor to set SDP to boot from a SPI FLASH on the daughter board

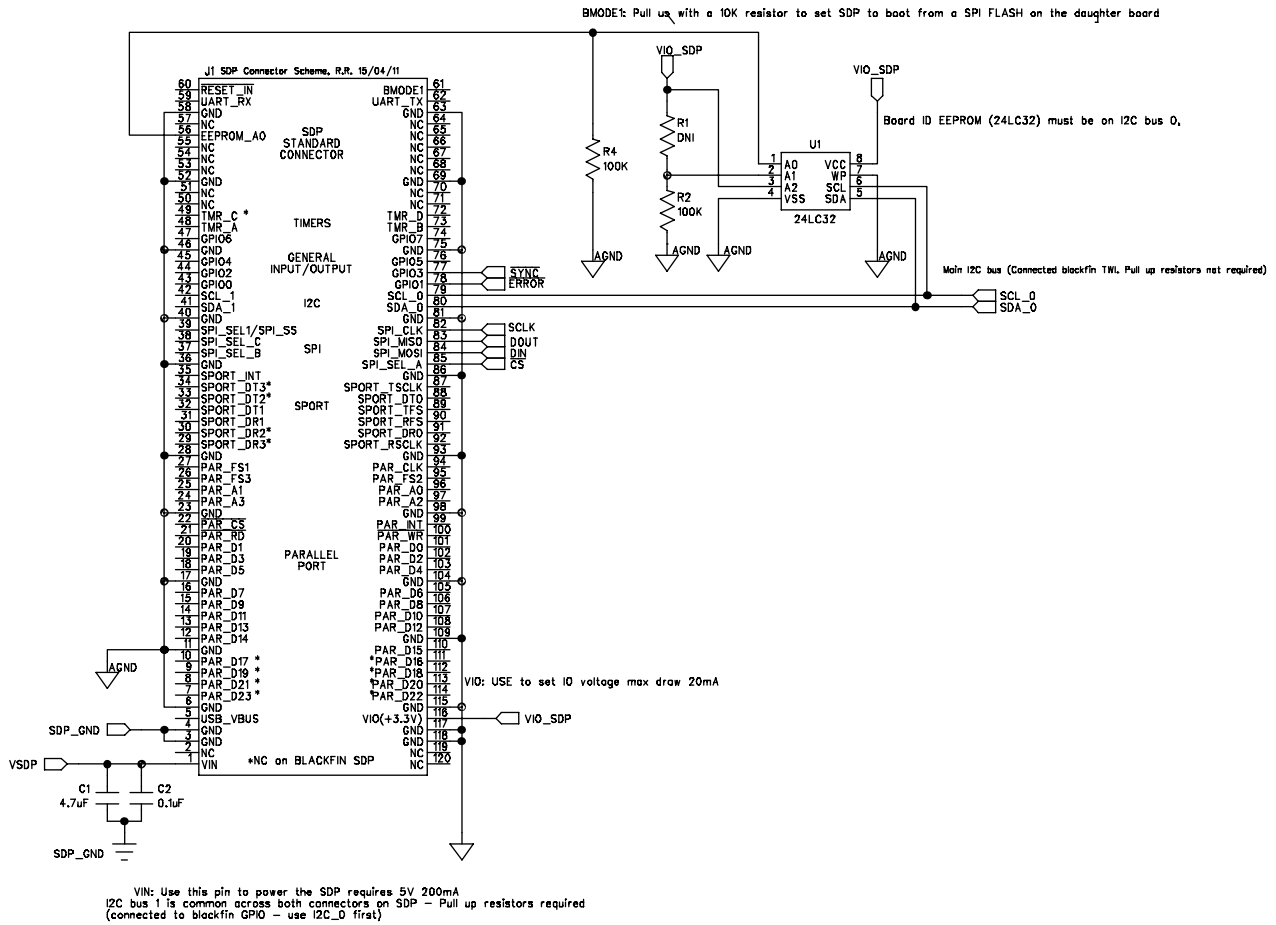

Figure 28. SDP-B Connector Schematic

12876-128

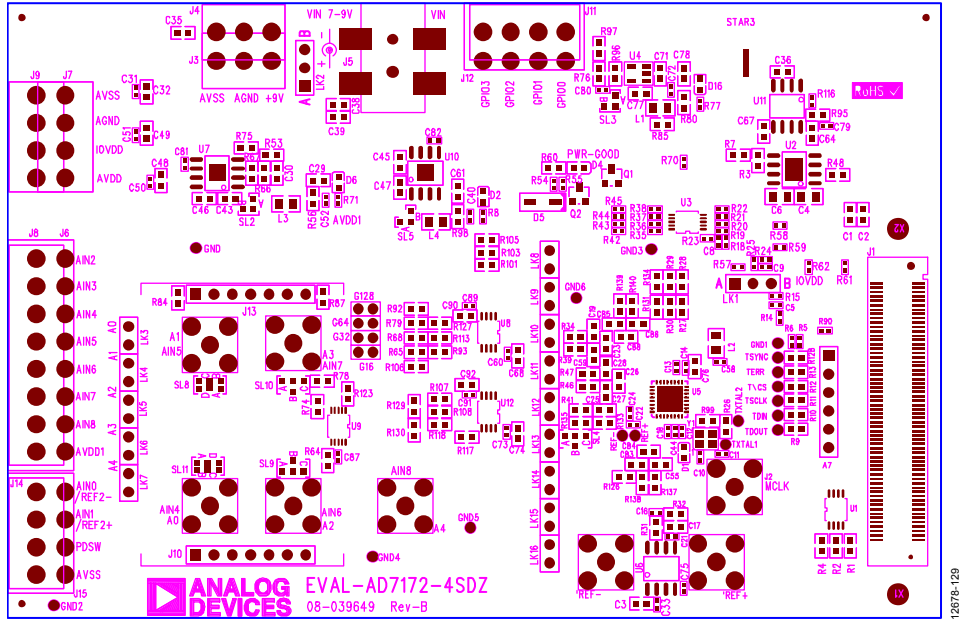

Figure 29. Top Printed Circuit Board (PCB) Silkscreen

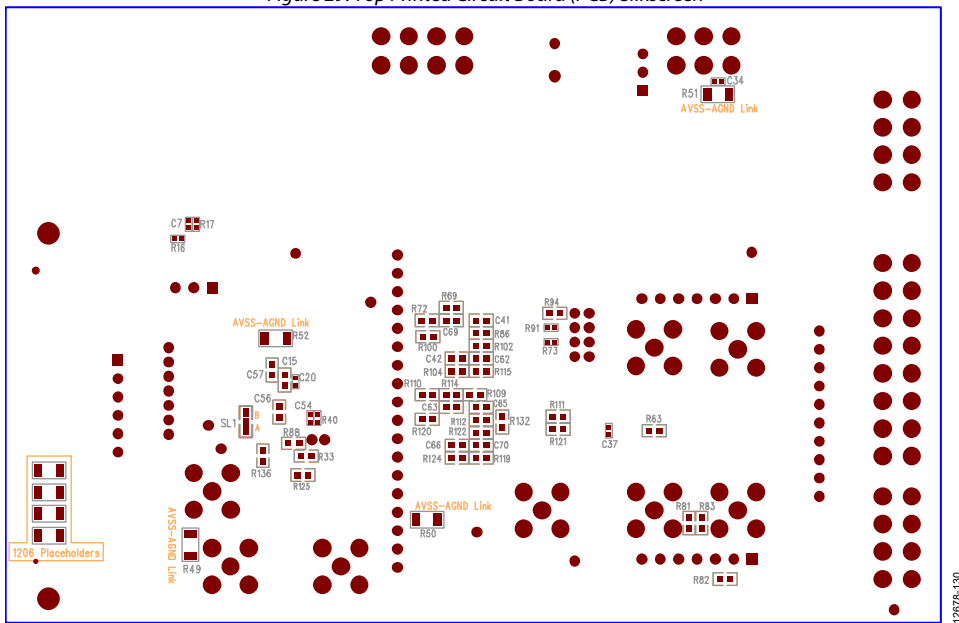

Figure 30. Bottom PCB Silkscreen

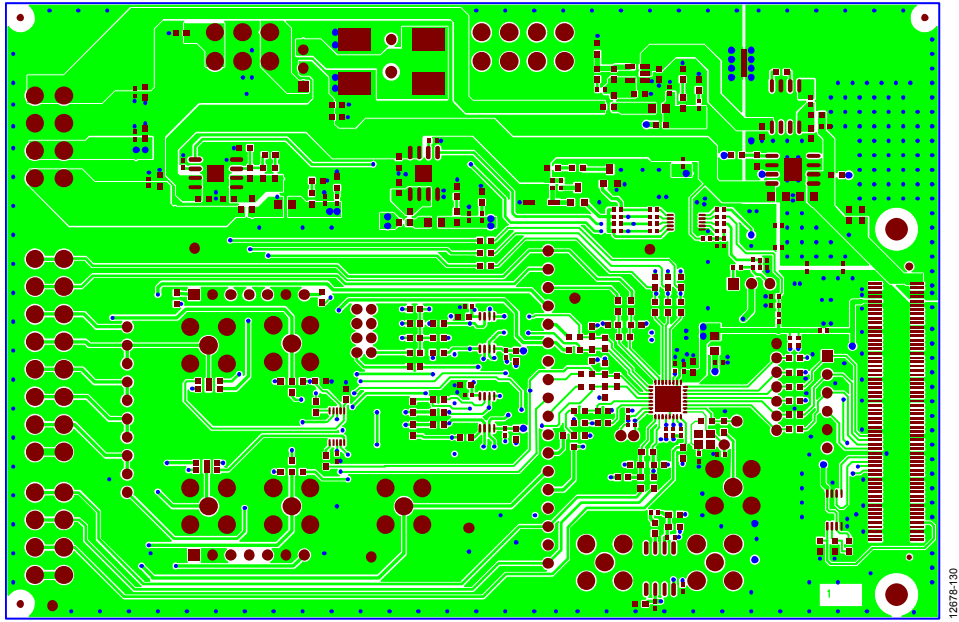

Figure 31. Layer 1 Component Side

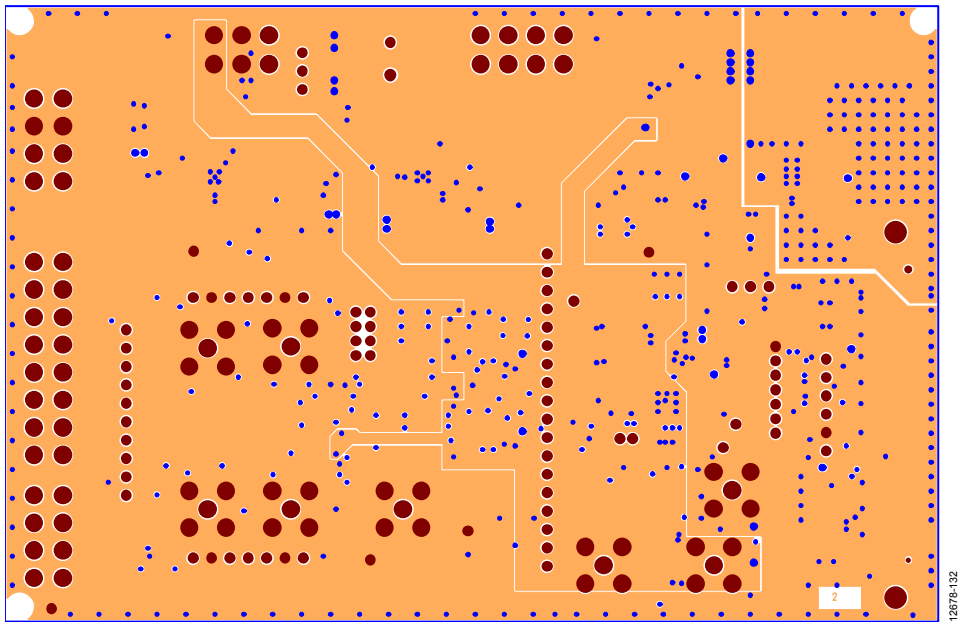
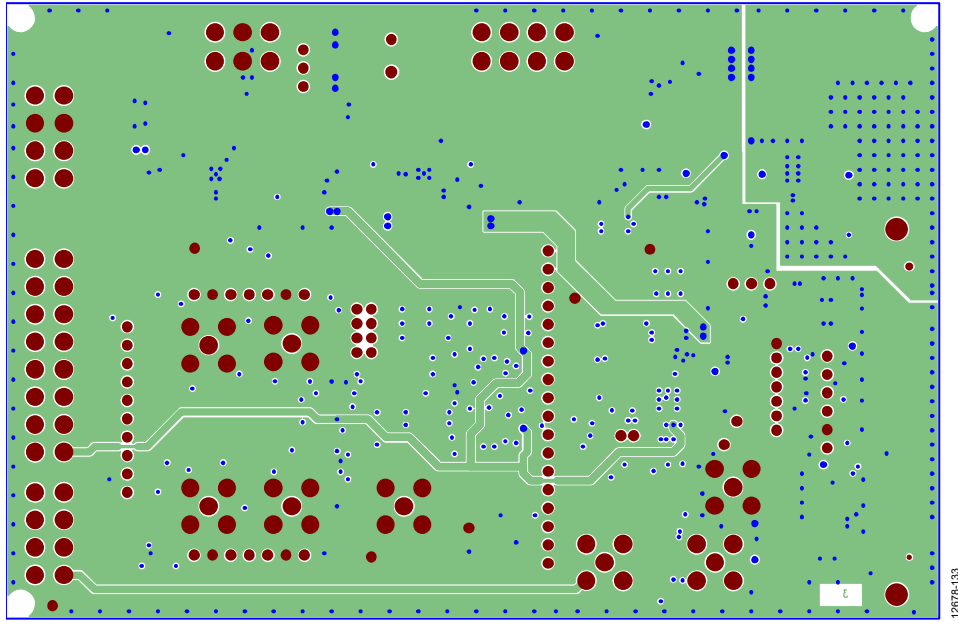
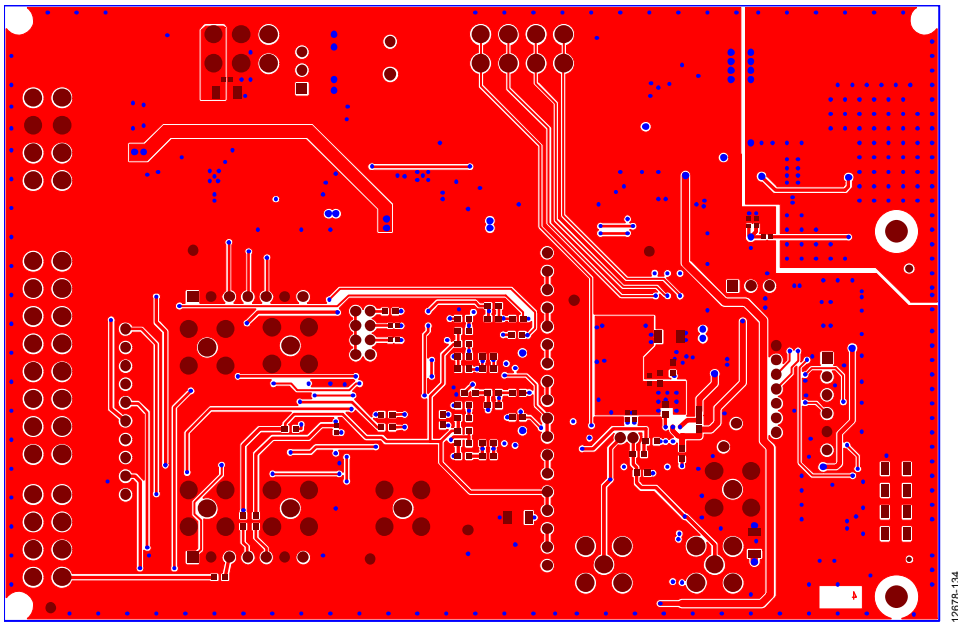

Figure 32. Layer 2 Ground Plane



12878-133

Figure 33. Layer 3 Power/Ground Plane



12878-134

Figure 34. Layer 4 Solder Side

ORDERING INFORMATION

BILL OF MATERIALS

Table 4.

Name	Part Description	Manufacturer	Part Number	Stock Code
A0 through A4	Straight PCB mount SMB jack, keep hole clear of solder. Do not insert.	TE Connectivity	1-1337482-0	Do not insert
A7	6-pin SIL header (0.1" pitch)	Harwin	20-9990646	FEC 1022255
C1, C17	Ceramic capacitor, 6.3 V, X5R, 0603, 4.7 μ F	Murata	GRM188R60J475K	FEC 173-5527
C2, C38	Ceramic capacitor, 50 V, X7R, 0603, 0.1 μ F	Murata	GRM188R71H104K	FEC 882-0023
C3	Ceramic capacitor, 10 V, X5R, 0603, 4.7 μ F	KEMET	C0603C475K8PACTU	FEC 157-2625
C4, C6	Capacitor, 0805, 50 V, X7R, 1 μ F	Murata	GRM21BR71H105KA12L	FEC 1735541
C5, C7 through C9, C16, C24 through C25, C29, C41 through C42, C61 through C63, C65 through C66, C69 through C70, C78 through C82	Ceramic capacitor, not inserted, 0402	Not applicable	Not applicable	Do not insert
C10-C11	Ceramic capacitor XTAL, not inserted, 0402	Not applicable	Not applicable	Do not insert
C12 through C14, C18, C20 through C22, C33 through C34, C37, C40, C44, C52 through C54, C58, C60, C72 through C73, C75, C87, C89, C91	Capacitor ceramic, 16 V, X7R, 0402	Murata	GRM155R71C104K	FEC 881-9742
C15, C30, C56 through C57, C76	Capacitor, 0603, 1 μ F, 6.3 V	Murata	GRM188R70J105KA01D	FEC 184-5765
C19, C27 through C28, C55, C59, C83, C85 through C86	Ceramic capacitor, 50 V, COG/NPO, 0603	AVX	06035A271JAT2A	FEC 1734627
C23, C26, C84, C88	Ceramic capacitor, 50 V, NPO, 0603	KEMET	C0603C681J5GACTU	FEC 1414648
C31, C50 through C51	Ceramic capacitor, 16 V, X7R, 0402, do not insert	Not applicable	Not applicable	Do not insert
C32, C35 through C36, C39, C48 through C49, C64, C67	Capacitor, MLCC (multilayer ceramic capacitor) X5R, 10 μ F, 10 V, 0603	TDK	C1608X5R1A106K080AC	FEC 221-1164
C43, C45 through C47, C71, C77	Capacitor, MLCC (multilayer ceramic capacitor), X5R, 2.2 μ F, 10 V, 0603	MCM Electronics	MC0603X225K100CT	FEC 232-0817
C68, C74, C90, C92	50 V X7R multilayer ceramic capacitor	Yageo	2238 586 15623	FEC 722170
D1 through D2, D6, D16	Red LED, high intensity (>90 mCd), 0603	Broadcom Ltd.	HSMC-C191	FEC 855-4528
D4	LED, SMD green	OSRAM	LGQ971	FEC 1226372
D5	Zener Diode, 0.5 W, 5.1 V	Vishay	BZT52B5V1-V-GS08	FEC 1617767
G16	2-pin (2 mm pitch) header and shorting shunt	Harwin	M22-2010205 & M22-1920005	FEC 671915 and 510944
G32, G64, G128	2-pin (2 mm pitch) header	Harwin	M22-2010205	FEC 671915

Name	Part Description	Manufacturer	Part Number	Stock Code
GND, GND1 through GND6, REF+, REF-, TDIN, TDOUT, TERR, TCLK, TSYNC, TXTAL1, TXTAL2, TVCS	Test point, not inserted, keep hole clear of solder	Not applicable	Not applicable	Do not insert
J1	120-way connector, 0.6 mm pitch	Hirose	FX8-120S-SV(21)	FEC 1324660
J2	Straight PCB mount SMB jack, keep hole clear of solder, do not insert	TE Connectivity	1-1337482-0	Do not insert
J3	Socket terminal block, 3.81 mm pitch	Phoenix Contact	MC 1.5/3-G-3.81	FEC 370-4737
J4	Screw terminal block, 3.81 mm pitch, do not insert	Phoenix Contact	1727023	Do not insert
J5	DC power connectors 2 mm SMT power jack	Lumberg	161314	FEC 1243245
J6	8-pin terminal header, 3.81 mm pitch, vertical	Phoenix Contact	MC 1,5/ 8-G-3,81	FEC 3704774
J7	Connector, pitch 3.81 mm, right angle	Phoenix Contact	MC 1,5/ 4-G-3,81 and 180-3594	Do not insert
J8	8-pin screw terminal, 3.81 mm pitch, vertical	Phoenix Contact	1727078	Do not insert
J9	Screw terminal block, 3.81 mm pitch	Phoenix Contact	1727036	FEC 370-4592
J10	7-way SSW 2.54 mm vertical socket (make sure to line up with connector on surf board)	Samtec	SSW-107-01-T-S	FEC 1803478
J11, J14	Screw terminal block, 3.81 mm pitch	Phoenix Contact	MKDS1/4-3.81	Do not insert.
J12	4-way power socket block, 3.81 mm pitch	Phoenix Contact	MC1.5/4-G-3.81	FEC 370-4749 and FEC 370-4920
J13	7-way SIP 2.54 mm TH Header (make sure to line up with connector on surf board)	Samtec	TLW-107-05-G-S	FEC 1668499
J15	4- way power socket block, 3.81 mm pitch	Phoenix Contact	MC1.5/4-G-3.81	FEC 370-4749 and FEC 370-4920
L1 through L4	Ferrite bead, 0.3 Ω at dc, 1000 Ω at 100 MHz, 350 mA, 0805	TE Connectivity	BMB2A1000LN2	FEC 119-3421
LK1 through LK2	3 pin (3 \times 1) 0.1" header and shorting block in A	Harwin	M20-9990346 & M7566-05	FEC 1022249 and 150-411
LK3 through LK7	2-pin (0.1" pitch) header	Harwin	M20-9990246	FEC 1022247
LK8 through LK16	2-pin (0.1" pitch) header and shorting shunt	Harwin	M20-9990246	FEC 1022247 and 150-411
Q1	SI2304DDS-T1-GE3 MOSFET, N CH, 30 V, 3.6 A, diode, SOT-23	Vishay	SI2304DDS-T1-GE3	FEC 1858939
Q2	Transistor, NPN, SOT-23	ON Semiconductor	MMBT3904LT1G	FEC 1459100
R1	Resistor, not inserted, 0603	Not applicable	Not applicable	Do not insert.
R2 through R4, R7, R48, R66, R75	Resistor, 100 K, 0.063 W, 1%, 0603	MCM Electronics	MC0063W06031100K	FEC 9330402
R5, R6, R77	Resistor, 10 K, 0.063 W, 1 %, 0402	MCM Electronics	MC00625W0402110K	FEC 1358069
R8, R71	Resistor, 1 %, 0402	Yageo	CRCW040210K0FKEAHP	FEC 173-8864

Name	Part Description	Manufacturer	Part Number	Stock Code
R9 through R13, R27, R30, R32, R41, R63, R78, R81 through R84, R87, R95, R99, R101, R103, R105, R107, R111, R114, R117, R121, R124, R128 through R131, R133	Resistor, 0603 1 % 0R	MCM Electronics	MC0063W06030R	FEC 9331662
R14	Resistor, 0402, 1 %, 39 K	MCM Electronics	MC 0.0625W 0402 1% 39K	FEC 1358085
R15, R17, R18, R24	SMD Resistor	MCM Electronics	MC 0.0625W 0402 1% 10K2	FEC 1803137
R16	Resistor, 0402, 1 %, 69K8	MCM Electronics	MC 0.0625W 0402 1% 69K8	FEC 1803735
R19 through R22, R35 through R38, R40, R58, R59, R61, R62, R70, R116	Resistor, 0402	Vishay	CRCW04020000Z0ED	FEC 146-9661
R23	Resistor, 0402, 1 %, 86K6	MCM Electronics	MC 0.0625W 0402 1% 86K6	FEC 1803744
R25, R57	Resistor, 0402, 1 %, 30k1	MCM Electronics	MC 0.0625W 0402 1% 30k1	FEC 1803699
R26, R28, R29, R31, R33, R56, R64, R67, R72, R74, R76, R80, R85, R86, R88, R98, R100, R102, R108 through R110, R112, R113, R115, R118 through R120, R122, R123, R125, R126, R132, R134, R135	SMD Resistor 0603	Not applicable	Not applicable	Do Not Insert
R34, R39, R46, R47, R137 through R140	Resistor, 10 R, 0.063 W, 1 %, 0603	MCM Electronics	MC0063W0603110R	FEC 9330429
R42 through R45	Resistor, Thick Film, 10 kΩ, 62.5 mW, 5 %	Yageo	RC0402JR-1310KL	FEC 179-9316
R49 through R52	Resistor, 1206	MCM Electronics	MC 0.125W 1206 0R	FEC 9336974
R53, R65, R136	Resistor, 10 K, 0.063 W, 1 %, 0603	MCM Electronics	MC0063W0603110K	FEC 9330399
R54	Resistor, Thick Film, 4.53 kΩ, 63 mW, 1 %	Vishay	CRCW04024K53FKED	FEC 1151244
R55	Resistor, 0402, 1 %, 61R9	MCM Electronics	MC 0.0625W 0402 1% 61R9	FEC 1802915
R60	Resistor, Thick Film, 2.4 kΩ, 0603, 100 mW, 1 %	Yageo	RC0603FR-072K4L	FEC 1799329
R68	Resistor, 0603, 4K75, 0.1 %, 0.1 W	Panasonic	ERA3ARB4751V	FEC 209-4611
R69, R104	Resistor, 0603, 0.1 %, 0.1 W, 75K	Panasonic	ERA3ARB753P	FEC 171-7620
R73	Resistor, 88R7, 0.063 W, 0.1 %, 0402	TE Connectivity	RN73C1E88R7B	FEC 173-7900
R79	Resistor, 121R, 0.063 W, 0.1 %, 0603	TE Connectivity/ Holsworthy	RN73C1J121RBTG	FEC 114-0465
R90	Resistor, not inserted, 0402	Not applicable	Not applicable	Do Not Insert
R91	Resistor, 2K26, 0.063 W, 0.1 %, 0402	TE Connectivity	RN73C1E2K26B	FEC 173-8050
R92	Resistor, 51R1, 0.063 W, 0.1 %, 0603	TE Connectivity/ Holsworthy	RN73C1J51R1BTG	FEC 114-0446
R93, R106	Resistor, 0603	Vishay	CRCW06030000Z0EA	FEC 146-9739
R94	Resistor, 0603, 1K13, 0.1 %, 0.1 W	Panasonic	ERA3ARB1131V	FEC 209-4485

Name	Part Description	Manufacturer	Part Number	Stock Code
R96	Resistor, 1K07, 0.063 W, 1 %, 0603	MCM Electronics	MC0063W060311K07	FEC 1170792
R97	Resistor, 1K02, 0.063 W, 1 %, 0603	MCM Electronics	MC0063W060311K02	FEC 1170789
R127	Resistor, 0603	Vishay	CRCW06030000Z0EA	FEC 146-9739
SL1	2-way Resistor Link Option	MCM Electronics	MC 0.063W 0603 0R	FEC 9331662
SL2, SL3	2-way Solder Link (Use Or 0603 Resistor)	Not applicable	Insert in Link Position "A"	FEC 933-1662
SL4	3-way Solder Link (Use Or 0603 Resistor)	Not applicable	Insert in Link Position "C"	FEC 933-1662
SL5	2-way Solder Link (Use Or 0603 Resistor)	Not applicable	Insert in Link Position "B"	FEC 933-1662
SL8	4-way Solder Link (Use Or 0603 Resistor)	Not applicable	Insert in Link Position "A"	FEC 933-1662
SL9, SL10	3-way Solder Link (Use Or 0603 Resistor)	Not applicable	Insert in Link Position "A"	FEC 933-1662
SL11	4-way Solder Link (Use Or 0603 Resistor)	Not applicable	Insert in Link Position "A"	FEC 933-1662
STAR3	Ground Link (Copper Short)	Not applicable	Not applicable	Not applicable
U1	32 K I ² C Serial EEPROM	Microchip Technology Inc.	24LC32A-I/MS	FEC1331330
U2	Linear Regulator 5 V, 20 V, 500 mA, Ultralow Noise, CMOS	Analog Devices, Inc.	ADP7104ARDZ-5.0	ADP7104ARDZ-5.0
U3	Quad Voltage Monitor and Sequencer	Analog Devices, Inc.	ADM1185ARMZ-1	ADM1185ARMZ-1
U4	8 V, -200 mA, Low Noise, Linear Regulator	Analog Devices, Inc.	ADP7182AUJZ	ADP7182AUJZ-R7
U5	ADC	Analog Devices, Inc.	AD7172-4BCPZ	AD7172-4BCPZ
U6	5 V XFET Reference	Analog Devices, Inc.	ADR445BRZ	ADR445BRZ
U7	Linear Regulator 2.5 V, Ultralow Noise, CMOS	Analog Devices, Inc.	ADP7118ARDZ-2.5	ADP7118ARDZ-2.5-R7
U8	5.0 V Ultralow Noise, Zero-Drift, RRIO, Dual Op-Amp	Analog Devices, Inc.	ADA4528-2ARMZ	ADA4528-2ARMZ
U9	Fully Differential Funnel Amplifier	Analog Devices, Inc.	AD8475ARMZ	AD8475ARMZ
U10	Linear Regulator 3.3 V, Ultralow Noise, CMOS	Analog Devices, Inc.	ADP7118ARDZ-3.3	ADP7118ARDZ-3.3-R7
U11	CMOS Switched-Capacitor Voltage Converter	Analog Devices, Inc.	ADM660ARZ	ADM660ARZ
U12	5.0 V Ultralow Noise, Zero-Drift, RRIO, Dual Op-Amp	Analog Devices, Inc.	ADA4528-2ARMZ	ADA4528-2ARMZ
V1 through V4	1206 Place Holder	Not applicable	Not applicable	Do Not Insert
X1, X2	3 mm NPTH Hole	Not applicable	MTHOLE-3 mm	
Y1	Miniature Crystal SMD	Epson	FA-20H, 16 MHz, 10 PPM, 9 PF	FEC 171-2814

NOTES



ESD Caution

ESD (electrostatic discharge) sensitive device. Charged devices and circuit boards can discharge without detection. Although this product features patented or proprietary protection circuitry, damage may occur on devices subjected to high energy ESD. Therefore, proper ESD precautions should be taken to avoid performance degradation or loss of functionality.

Legal Terms and Conditions

By using the evaluation board discussed herein (together with any tools, components documentation or support materials, the "Evaluation Board"), you are agreeing to be bound by the terms and conditions set forth below ("Agreement") unless you have purchased the Evaluation Board, in which case the Analog Devices Standard Terms and Conditions of Sale shall govern. Do not use the Evaluation Board until you have read and agreed to the Agreement. Your use of the Evaluation Board shall signify your acceptance of the Agreement. This Agreement is made by and between you ("Customer") and Analog Devices, Inc. ("ADI"), with its principal place of business at One Technology Way, Norwood, MA 02062, USA. Subject to the terms and conditions of the Agreement, ADI hereby grants to Customer a free, limited, personal, temporary, non-exclusive, non-sublicensable, non-transferable license to use the Evaluation Board FOR EVALUATION PURPOSES ONLY. Customer understands and agrees that the Evaluation Board is provided for the sole and exclusive purpose referenced above, and agrees not to use the Evaluation Board for any other purpose. Furthermore, the license granted is expressly made subject to the following additional limitations: Customer shall not (i) rent, lease, display, sell, transfer, assign, sublicense, or distribute the Evaluation Board; and (ii) permit any Third Party to access the Evaluation Board. As used herein, the term "Third Party" includes any entity other than ADI, Customer, their employees, affiliates and in-house consultants. The Evaluation Board is NOT sold to Customer; all rights not expressly granted herein, including ownership of the Evaluation Board, are reserved by ADI. CONFIDENTIALITY. This Agreement and the Evaluation Board shall all be considered the confidential and proprietary information of ADI. Customer may not disclose or transfer any portion of the Evaluation Board to any other party for any reason. Upon discontinuation of use of the Evaluation Board or termination of this Agreement, Customer agrees to promptly return the Evaluation Board to ADI. ADDITIONAL RESTRICTIONS. Customer may not disassemble, decompile or reverse engineer chips on the Evaluation Board. Customer shall inform ADI of any occurred damages or any modifications or alterations it makes to the Evaluation Board, including but not limited to soldering or any other activity that affects the material content of the Evaluation Board. Modifications to the Evaluation Board must comply with applicable law, including but not limited to the RoHS Directive. TERMINATION. ADI may terminate this Agreement at any time upon giving written notice to Customer. Customer agrees to return to ADI the Evaluation Board at that time. LIMITATION OF LIABILITY. THE EVALUATION BOARD PROVIDED HEREUNDER IS PROVIDED "AS IS" AND ADI MAKES NO WARRANTIES OR REPRESENTATIONS OF ANY KIND WITH RESPECT TO IT. ADI SPECIFICALLY DISCLAIMS ANY REPRESENTATIONS, ENDORSEMENTS, GUARANTEES, OR WARRANTIES, EXPRESS OR IMPLIED, RELATED TO THE EVALUATION BOARD INCLUDING, BUT NOT LIMITED TO, THE IMPLIED WARRANTY OF MERCHANTABILITY, TITLE, FITNESS FOR A PARTICULAR PURPOSE OR NON-INFRINGEMENT OF INTELLECTUAL PROPERTY RIGHTS. IN NO EVENT WILL ADI AND ITS LICENSORS BE LIABLE FOR ANY INCIDENTAL, SPECIAL, INDIRECT, OR CONSEQUENTIAL DAMAGES RESULTING FROM CUSTOMER'S POSSESSION OR USE OF THE EVALUATION BOARD, INCLUDING BUT NOT LIMITED TO LOST PROFITS, DELAY COSTS, LABOR COSTS OR LOSS OF GOODWILL. ADI'S TOTAL LIABILITY FROM ANY AND ALL CAUSES SHALL BE LIMITED TO THE AMOUNT OF ONE HUNDRED US DOLLARS (\$100.00). EXPORT. Customer agrees that it will not directly or indirectly export the Evaluation Board to another country, and that it will comply with all applicable United States federal laws and regulations relating to exports. GOVERNING LAW. This Agreement shall be governed by and construed in accordance with the substantive laws of the Commonwealth of Massachusetts (excluding conflict of law rules). Any legal action regarding this Agreement will be heard in the state or federal courts having jurisdiction in Suffolk County, Massachusetts, and Customer hereby submits to the personal jurisdiction and venue of such courts. The United Nations Convention on Contracts for the International Sale of Goods shall not apply to this Agreement and is expressly disclaimed.

©2015–2017 Analog Devices, Inc. All rights reserved. Trademarks and registered trademarks are the property of their respective owners.

UG12678-0-10/17(A)



www.analog.com