

Verpackt in Gurtverpackung
Tape on Reel Packaging
Verpackungseinheit: 400 Stück
Packaging unit: 400 pcs

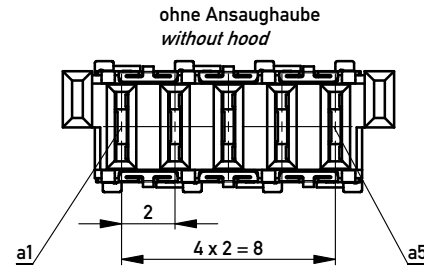

Abspulrichtung - Reel off Direction

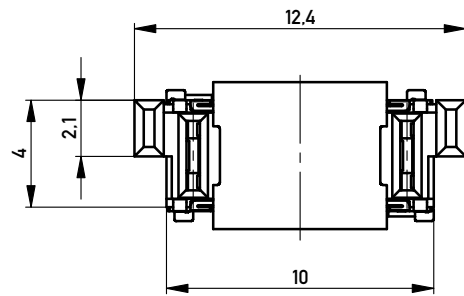
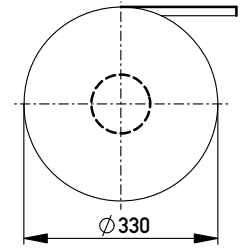
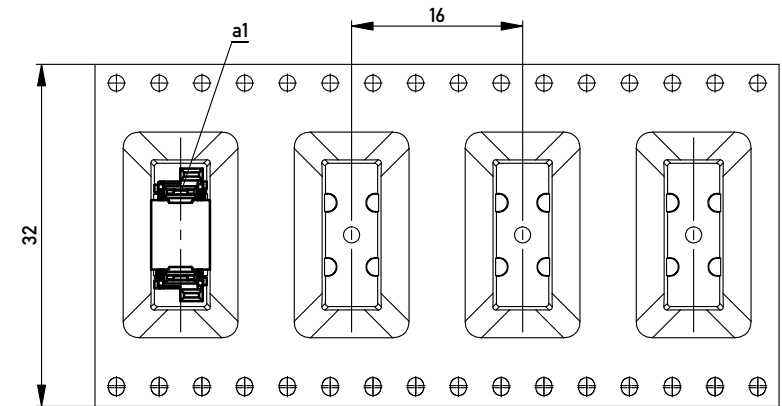

Leiterplatten-Layout Vorschlag / PCB-layout proposal

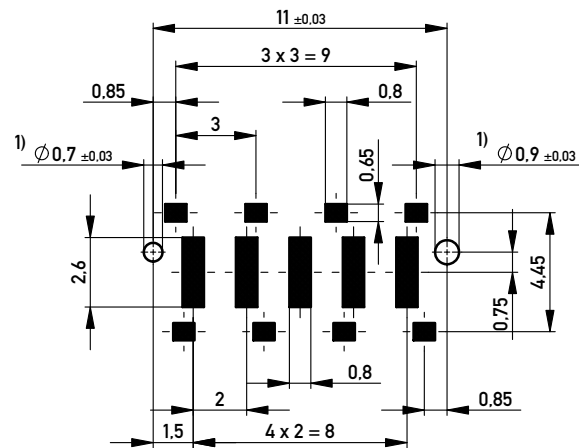

1) Durchmesser des Bohrers / Drill tool

Anforderungsstufe 1
Performance Level 1

Kontaktbereich vergoldet
Mating Area gold plating

Anschlussbereich verzinkt 4-6µm
Terminal Area 4-6µm tin plating

Koplanarität der Anschlüsse ≤ 0.1mm
Coplanarity Area of Termination ≤ 0.1mm

Information:	Tolerances	 All Dimensions in mm	Scale	5:1
	All rights reserved. Only for Information. To ensure that this is the latest version of this drawing, please contact one of the ERNI companies before using.		Designation F04 MSPEED BlindMate PM SMD	
Subject to modification without prior notice. Drawing will not be updated.		 www.ERNI.com	354262	
b	14.09.2012		Class MSPEED	
Index	Date	I A3		

Copyright by ERNI GmbH. Proprietary notice pursuant to ISO 9006 to be observed.