

NOTES:

1. MATERIALS:
HOUSING - LIQUID CRYSTAL POLYMER (LCP),
GLASS-FILLED, UL 94V-0, COLOR: BLACK
SIGNAL PIN & SHIELD - COPPER ALLOY
2. FINISHES:
CONTACT AREA: SELECTIVE GOLD (Au)
PCB TAILS: SELECTIVE MATTE TIN (Sn)
NICKEL (Ni) OVERALL.
3. THIS PART CONFORMS TO MOLEX PRODUCT SPECIFICATION PS-74031-999
4. FOR MIXED CONTACT LENGTHS CONSULT MOLEX FOR AVAILABILITY
5. FOR SPECIFIC MATERIAL NUMBERS & MATING INFORMATION REFER TO SHEET 2
6. PACKAGE PER PK-74058-003
7. MARK PART WITH PART NUMBER & DATE CODE APPROXIMATELY WHERE SHOWN
8. MAPS (MOLEX ADVANCED PLATING SYSTEM).

THE PRIMARY CARTON WITH A LABEL STATING "ELV AND RoHS COMPLAINT" IS LEAD FREE. CARTONS WITHOUT THIS LABEL MAY CONTAIN LEAD.

LEAD FREE CONVERSION EC NO: UCP2013-0687 DRAWINGS: 2012/08/21 CHKD: MWOLF 2012/11/26 APPR: SMILLER 2012/12/14	QUALITY SYMBOLS ▽=0 ▽=0 ▽=0	GENERAL TOLERANCES (UNLESS SPECIFIED)		DIMENSION STYLE MM ONLY	SCALE 2.5:1	DESIGN UNITS METRIC	THIRD ANGLE PROJECTION		
		4 PLACES ± --- ± --- 3 PLACES ± --- ± --- 2 PLACES ± --- ± --- 1 PLACE ± --- ± --- 0 PLACE ± ±	mm INCH	DRAWN BY JMELTON	DATE 2010/05/19	TITLE VHDM 6 ROW SIGNAL END BACKPLANE SALES ASSEMBLY			
		ANGULAR ±1/2°		CHECKED BY SDANNELLEY	DATE 2010/05/19	molex			
		DRAFT WHERE APPLICABLE MUST REMAIN WITHIN DIMENSIONS		APPROVED BY SMILLER	DATE 2010/07/14	MATERIAL NO. SEE SHEET 2	DOCUMENT NO. SD-74058-002	SHEET NO. 1 OF 2	
THIS DRAWING CONTAINS INFORMATION THAT IS PROPRIETARY TO MOLEX INCORPORATED AND SHOULD NOT BE USED WITHOUT WRITTEN PERMISSION									

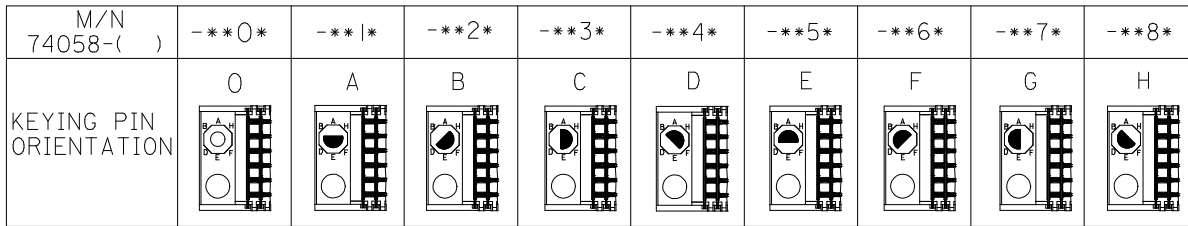

74058 * * * *

CONTACT LOAD (PIN LENGTH)
 1 = 4.75
 2 = 4.25
 3 = 3.75
 4 = 3.25
 5 = 2.75
 6 = 2.25
 7 = 1.75
 8 = 1.25

NUMBER OF COLUMNS/PLATING
 10 = 10 COLUMN MATTE TIN (FORMERLY TIN/LEAD)
 25 = 25 COLUMN MATTE TIN (FORMERLY TIN/LEAD)
 60 = 10 COLUMN MATTE TIN (MAPS)
 75 = 25 COLUMN MATTE TIN (MAPS)
 90 = 10 COLUMN MATTE TIN
 85 = 25 COLUMN MATTE TIN

PART NUMBER	COLUMN	NUMBER OF SIGNAL PIN	NUMBER OF SHIELD	A	B	M	GOLD THICKNESS MICROMETER	TIN THICKNESS MICROMETER
74058-60*1	10	60	10	27.00	18.00	4.75	0.25 MAPS	0.76-1.52
74058-x0*1							0.76	
74058-x0*6							1.27	
74058-75*1	25	150	25	57.00	48.00	4.75	0.25 MAPS	
74058-x5*1							0.76	
74058-x5*6							1.27	
74058-60*2	10	60	10	27.00	18.00	6.25	0.25 MAPS	
74058-x0*2							0.76	
74058-x0*7							1.27	
74058-75*2	25	150	25	57.00	48.00	6.25	0.25 MAPS	
74058-x5*2							0.76	
74058-x5*7							1.27	
74058-60*3	10	60	10	27.00	18.00	4.25	0.25 MAPS	
74058-x0*3							0.76	
74058-x0*8							1.27	
74058-75*3	25	150	25	57.00	48.00	4.25	0.25 MAPS	
74058-x5*3							0.76	
74058-x5*8							1.27	
74058-60*4	10	60	10	27.00	18.00	5.15	0.25 MAPS	
74058-x0*4							0.76	
74058-x0*9							1.27	
74058-75*4	25	150	25	57.00	48.00	5.15	0.25 MAPS	
74058-x5*4							0.76	
74058-x5*9							1.27	

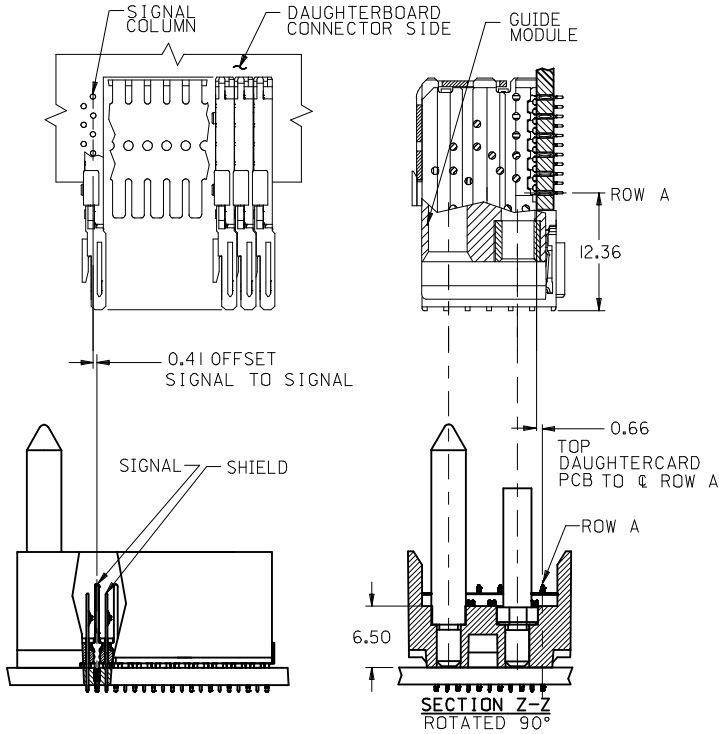

SEE SHEET 1 EC NO: UCP2013-0687 DRAWINGS: 2012/08/21 CHKD: MWOLFE 2012/11/26 APPR: SMILLER 2012/12/14 REV M	QUALITY SYMBOLS	GENERAL TOLERANCES (UNLESS SPECIFIED)	DIMENSION STYLE MM ONLY	SCALE 2.5:1	DESIGN UNITS METRIC	THIRD ANGLE PROJECTION
	▽=0	mm INCH	DRAWN BY DATE JMELTON 2010/05/19	TITLE VHDM 6 ROW SIGNAL END BACKPLANE SALES ASSEMBLY		
	▽=0	4 PLACES ± --- ± ---	CHECKED BY DATE SDANNELLEY 2010/05/19			
	▽=0	3 PLACES ± --- ± ---	APPROVED BY DATE SMILLER 2010/07/14			
	▽=0	2 PLACES ± --- ± ---	MATERIAL NO.	DOCUMENT NO.	SHEET NO.	
	1 PLACE ± --- ± ---	SEE TABLE	SD-74058-002	2 OF 2		
	0 PLACE ± --- ± ---	ANGULAR ±1/2°	THIS DRAWING CONTAINS INFORMATION THAT IS PROPRIETARY TO MOLEX INCORPORATED AND SHOULD NOT BE USED WITHOUT WRITTEN PERMISSION			

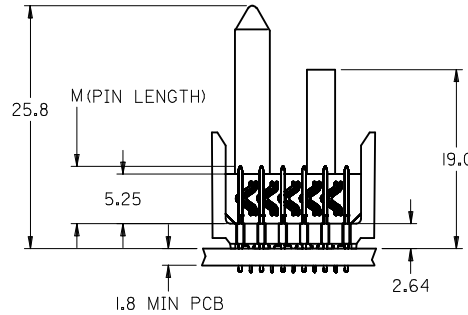
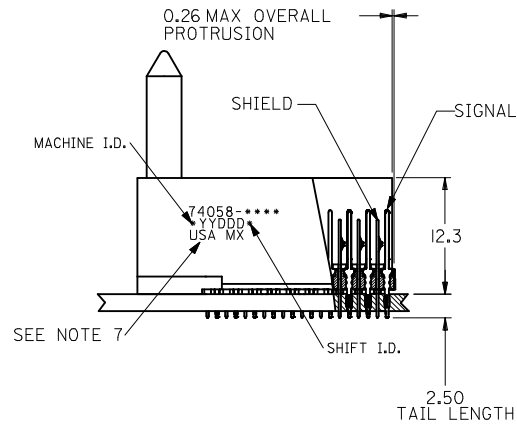
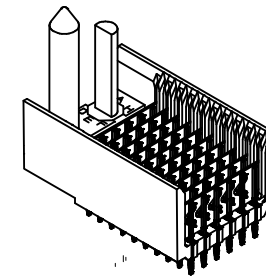
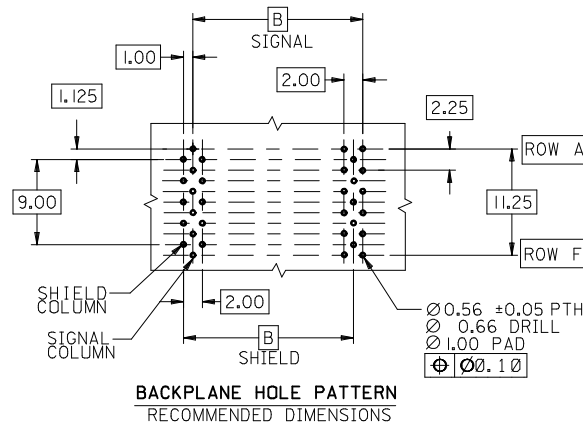
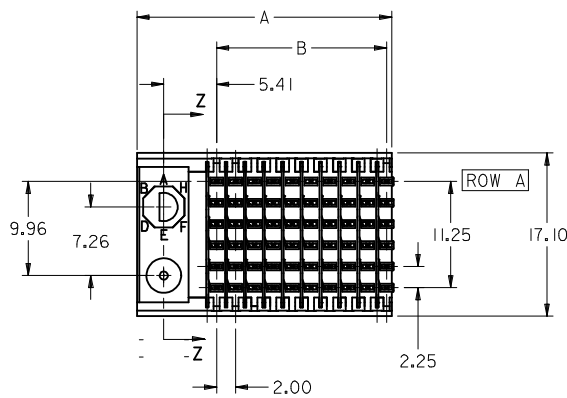

NOTES:

1. MATERIALS:
HOUSING - LIQUID CRYSTAL POLYMER (LCP),
GLASS-FILLED, UL 94V-0, COLOR: BLACK
SIGNAL PIN & SHIELD - COPPER ALLOY
2. FINISHES:
CONTACT AREA: SELECTIVE GOLD (Au)
PCB TAILS: SELECTIVE MATTE TIN (Sn)
NICKEL (Ni) OVERALL.
3. THIS PART CONFORMS TO MOLEX PRODUCT SPECIFICATION PS-74031-999
4. FOR MIXED CONTACT LENGTHS CONSULT MOLEX FOR AVAILABILITY
5. FOR SPECIFIC MATERIAL NUMBERS & MATING INFORMATION REFER TO SHEET 2
6. PACKAGE PER PK-74058-003
7. MARK PART WITH PART NUMBER & DATE CODE APPROXIMATELY WHERE SHOWN
8. MAPS (MOLEX ADVANCED PLATING SYSTEM).

THE PRIMARY CARTON WITH A LABEL STATING "ELV AND RoHS COMPLAINT" IS LEAD FREE. CARTONS WITHOUT THIS LABEL MAY CONTAIN LEAD.

LEAD FREE CONVERSION EC NO: UCP2013-0687 DRAWINGS: 2012/08/21 CHKD:MMWLF 2012/11/26 APPR:SMILLER 2012/12/14	QUALITY SYMBOLS ▽=0 ▽=0 ▽=0	GENERAL TOLERANCES (UNLESS SPECIFIED)		DIMENSION STYLE MM ONLY	SCALE 2.5:1	DESIGN UNITS METRIC	THIRD ANGLE PROJECTION
		mm	INCH	DRAWN BY JMELTON	DATE 2010/05/19	TITLE VHDM 6 ROW SIGNAL END BACKPLANE SALES ASSEMBLY	DOCUMENT NO. SD-74058-002
REV: M	DESCRIPTION	4 PLACES ±	±	CHECKED BY SDANNELLEY	DATE 2010/05/19	molex	
		3 PLACES ±	±	APPROVED BY SMILLER	DATE 2010/07/14		
ANGULAR ±1/2°		DRAFT WHERE APPLICABLE MUST REMAIN WITHIN DIMENSIONS		MATERIAL NO. SEE SHEET 2		THIS DRAWING CONTAINS INFORMATION THAT IS PROPRIETARY TO MOLEX INCORPORATED AND SHOULD NOT BE USED WITHOUT WRITTEN PERMISSION	

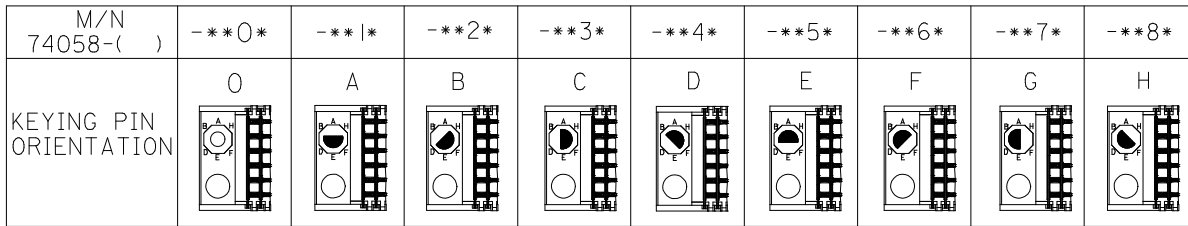

74058 * * * *

CONTACT LOAD (PIN LENGTH)
 1 = 4.75
 2 = 4.25
 3 = 3.75
 4 = 3.25
 5 = 2.75
 6 = 2.25
 7 = 1.75
 8 = 1.25

NUMBER OF COLUMNS/PLATING
 10 = 10 COLUMN MATTE TIN (FORMERLY TIN/LEAD)
 25 = 25 COLUMN MATTE TIN (FORMERLY TIN/LEAD)
 60 = 10 COLUMN MATTE TIN (MAPS)
 75 = 25 COLUMN MATTE TIN (MAPS)
 90 = 10 COLUMN MATTE TIN
 85 = 25 COLUMN MATTE TIN

PART NUMBER	COLUMN	NUMBER OF SIGNAL PIN	NUMBER OF SHIELD	A	B	M	GOLD THICKNESS MICROMETER	TIN THICKNESS MICROMETER
74058-60*1	10	60	10	27.00	18.00	4.75	0.25 MAPS	0.76-1.52
74058-x0*1							0.76	
74058-x0*6							1.27	
74058-75*1	25	150	25	57.00	48.00	4.75	0.25 MAPS	
74058-x5*1							0.76	
74058-x5*6							1.27	
74058-60*2	10	60	10	27.00	18.00	6.25	0.25 MAPS	
74058-x0*2							0.76	
74058-x0*7							1.27	
74058-75*2	25	150	25	57.00	48.00	6.25	0.25 MAPS	
74058-x5*2							0.76	
74058-x5*7							1.27	
74058-60*3	10	60	10	27.00	18.00	4.25	0.25 MAPS	
74058-x0*3							0.76	
74058-x0*8							1.27	
74058-75*3	25	150	25	57.00	48.00	4.25	0.25 MAPS	
74058-x5*3							0.76	
74058-x5*8							1.27	
74058-60*4	10	60	10	27.00	18.00	5.15	0.25 MAPS	
74058-x0*4							0.76	
74058-x0*9							1.27	
74058-75*4	25	150	25	57.00	48.00	5.15	0.25 MAPS	
74058-x5*4							0.76	
74058-x5*9							1.27	

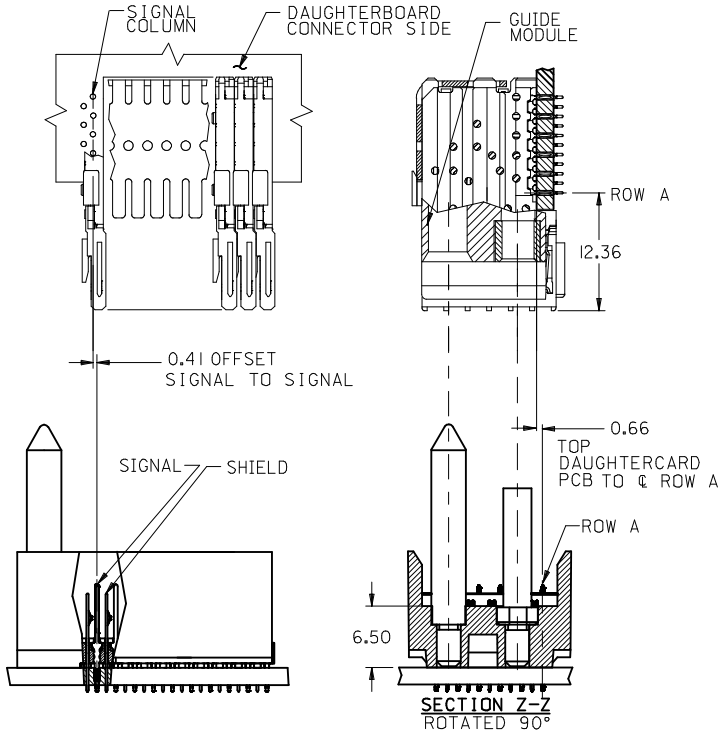

SEE SHEET 1 EC NO: UCP2013-0687 DRWINGS 2012/08/21 CHKD:HWOLF 2012/11/26 APPR:SMILLER 2012/12/14	QUALITY SYMBOLS	GENERAL TOLERANCES (UNLESS SPECIFIED)	DIMENSION STYLE MM ONLY	SCALE 2.5:1	DESIGN UNITS METRIC	THIRD ANGLE PROJECTION
	▽=0	mm INCH	DRAWN BY DATE JMELTON 2010/05/19	TITLE VHDM 6 ROW SIGNAL END BACKPLANE SALES ASSEMBLY		
	▽=0	4 PLACES ± --- ± ---	CHECKED BY DATE SDANNELLEY 2010/05/19	molex DOCUMENT NO. SD-74058-002 SHEET NO. 2 OF 2		
	▽=0	3 PLACES ± --- ± ---	APPROVED BY DATE SMILLER 2010/07/14			
	▽=0	2 PLACES ± --- ± ---	MATERIAL NO. SEE TABLE DRAFT WHERE APPLICABLE MUST REMAIN WITHIN DIMENSIONS			
▽=0	1 PLACE ± --- ± ---	THIS DRAWING CONTAINS INFORMATION THAT IS PROPRIETARY TO MOLEX INCORPORATED AND SHOULD NOT BE USED WITHOUT WRITTEN PERMISSION				