

- NOTES:
1. ALL DIMENSIONS FOR REFERENCE ONLY.
 2. CHASSIS IS RED ANODIZED ALUMINUM WITH LASER ETCHED WHITE TEXT AND ARTWORK.
 3. DESIGNATION STRIPS SHIPPED UNASSEMBLED.
 4. THIS PRODUCT IS RoHS COMPLIANT.

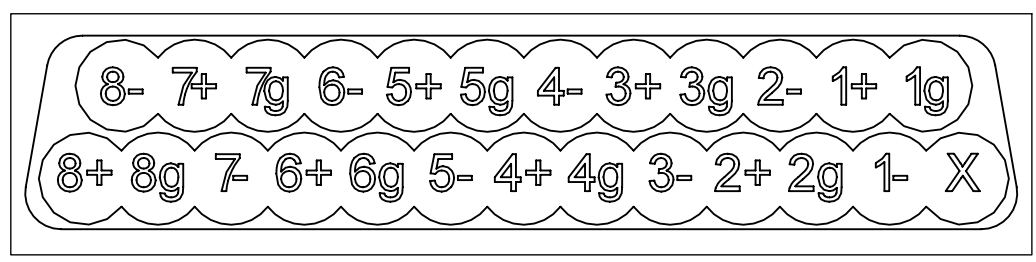
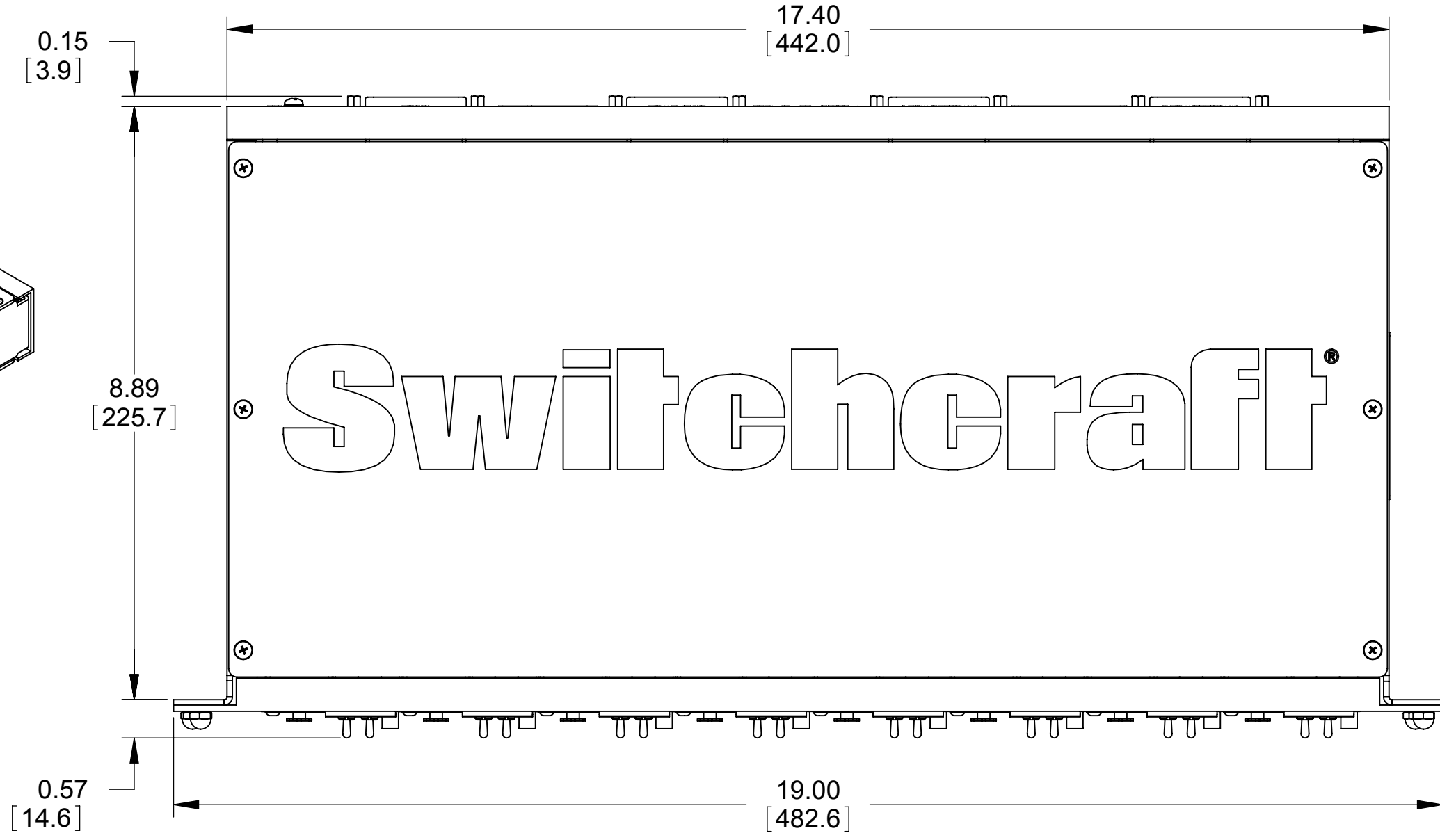

FEMALE DB25 PINOUT
(WIRED TO TASCAM DTRS STANDARD)

CUSTOMER DRAWING

UNLESS OTHERWISE SPECIFIED					THIS DRAWING DESCRIBES A DESIGN CONSIDERED PROPRIETARY IN NATURE, DEVELOPED AND MANUFACTURED BY SWITCHCRAFT INC. AND IS RELEASED ON A CONFIDENTIAL BASIS FOR IDENTIFICATION PURPOSES ONLY.				
1. ALL DIMENSIONS IN INCHES [mm]					SIZE	WIDTH	MULT	LBS/M	TEMPER
- TWO PLACE DECIMALS ±0.02 [0.5]					FINISH				MATERIAL
- THREE PLACE DECIMALS ±0.005 [0.13]					FIRST USED ON				SPEC No.
					SCALE				1:1
					DATE DRAWN	BY	CHKD	APVD	Switchcraft®
					3/3/10	BHM	03/29/17	03/29/17	
					NAME				SHEET 1 OF 3
					AUDIO SPLITTER				REV A
					8 CHANNEL / 3-WAY, RoHS				PART No. RMAS8
REVISIONS					DO NOT SCALE DRAWING				

RMAS8 Audio Splitter Audio Specifications

Switchcraft®

Parameter	Performance	Conditions
Frequency Response	10Hz - 20kHz	+/-0.5dB, ref 1kHz
Total Harmonic Distortion + Noise	< 0.015% < 0.07%	at 1kHz, -20dBu Input, 22kHz Bandwidth at 20Hz, -20dBu Input, 22kHz Bandwidth
Maximum Input Level	+4dBu	at 20Hz with 1% THD+Noise
Input Impedance	> 390Ω	at 1kHz
Output Impedance	< 200Ω	at 1kHz
Common Mode Rejection Ratio (CMRR)	> 108dB	at 60Hz
Deviation from Linear Phase	< 2° < 1° < 24°	at 20Hz at 1kHz at 20kHz
Crosstalk	< -95dB	20Hz - 20kHz, Channel-to-Channel
Voltage Gain		
Direct Output	-2.8dB	+/-1dB
Direct Output (Pad On)	-1.0dB	+/-1dB
Isolated Outputs	-4.0dB	+/-1dB
Isolated Outputs (Pad On)	-44.3dB	+/-1dB
Pad Attenuation	40.3dB	+/-1dB

Notes: All measurements were taken with a 150Ω balanced source with 1.5kΩ loads on all three outputs.
Specifications subject to change without notice.

CUSTOMER DRAWING

SCALE 1:2	Switchcraft®	
DATE DRAWN 3/3/10		
DRAWN BY BHM	PART No. RMAS8	REV A

8

7

6

5

4

3

2

1

F

E

D

C

B

A

F

E

D

C

B

A

INPUT
PARALLEL CONNECTION
BETWEEN FRONT XLR
AND DB25

DIRECT OUT
DB25

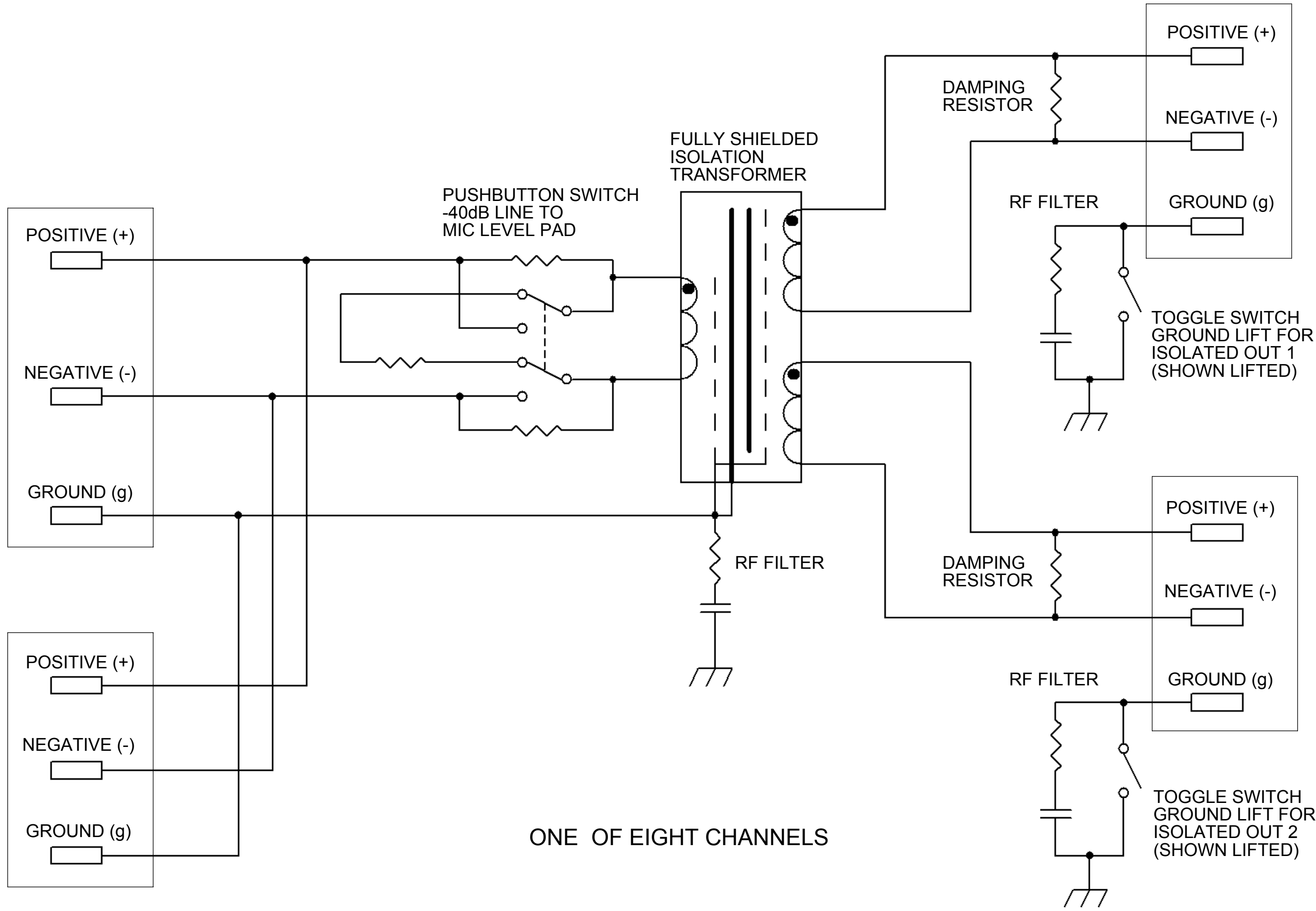

ONE OF EIGHT CHANNELS

ISOLATED OUT 1
DB25

ISOLATED OUT 2
DB25

CUSTOMER DRAWING

SCALE 1:2	Switchcraft [®]	
DATE DRAWN 3/3/10		
DRAWN BY BHM	PART No. RMAS8	REV A