



TMC457 – DATA SHEET

S-profile motion controller with PID feedback control and high resolution micro stepping sequencer for stepper motors and piezo motors

TRINAMIC® Motion Control GmbH & Co. KG

Hamburg
GERMANY
www.trinamic.com



1 Features

The TMC457 is a high end single axis micro stepping motion controller. It adds to any microcontroller or processor with SPI™ (SPI is Trademark of Motorola) interface. It is intended for applications, where a precise and fast, jerk-free motion profile is desired. An encoder can be added for extremely quick and precise positioning using the internal hardware PID regulator and provides for increased reliability / fault detection. The high-resolution micro step sequencer directly controls stepper motors and piezo motors. Wide range motion control parameters eliminate any “gear switching”. The TMC457 supports linear velocity ramps and S-shaped velocity ramps. For maximum flexibility all motion control parameters (target position, target velocity, acceleration, deceleration and bow) can be changed any time during motion.

Highlights

- S-shaped and linear ramps with on-the-fly alteration of all parameters
- Programmable high resolution sequencer with (12 bit, 8192 entry) micro step look-up table
- Incremental encoder interface with flexible up- and down scaling to match drive resolution
- Fast and stable easyPID™ PID controller
- 32 bit registers – from mHz to MHz / from nanometer to meter
- SPI interface to microcontroller
- Reference switch processing / virtual stop switches (programmable soft limits)
- Step / direction output (with programmable timing)
- Position pulse output to trigger external events
- Synchronization of multiple axis via scalable step / direction input
- Direct interface for TMC246/TMC249 family stepper motor drivers supports StallGuard™ (pat.)
- ChopSync™ (pat. fil.) built in for best motor velocity range
- Analog high resolution motor driver control via external dual 12 bit DAC
- Automatic load angle limitation using encoder for stepless servo behaviour

Types of Motors

- Two phase stepper motors (direct sequencer support)
- PiezoMotors (direct sequencer support for PiezoMotor's PiezoLEGS® motor)
- Any type of motor via step/direction interface

Applications

- Medical and laboratory equipment with high speed motion e.g. for liquid handling
- High end placement and positioning systems / High reliability drives
- Sub-micrometer positioning (piezo motors)
- Active stabilization with incremental encoder and fast PID regulator

Life support policy

TRINAMIC Motion Control GmbH & Co. KG does not authorize or warrant any of its products for use in life support systems, without the specific written consent of TRINAMIC Motion Control GmbH & Co. KG.

Life support systems are equipment intended to support or sustain life, and whose failure to perform, when properly used in accordance with instructions provided, can be reasonably expected to result in personal injury or death.

© TRINAMIC Motion Control GmbH & Co. KG 2008

Information given in this data sheet is believed to be accurate and reliable. However no responsibility is assumed for the consequences of its use nor for any infringement of patents or other rights of third parties which may result from its use.

Specification is subject to change without notice.

2 Contents

1	FEATURES	1
2	CONTENTS	3
2.1	Figures	4
2.2	Tables	4
3	GENERAL DESCRIPTION	5
4	TMC457 BLOCK DIAGRAM AND INTERFACES	6
4.1	Microcontroller Interface (SPI™).....	6
4.2	Step Direction Inputs.....	6
4.3	DAC (LTC2602) Interface	6
4.3.1	Piezo Motor Driver	6
4.4	Stepper Motor Driver Interface (TMC236, TMC239, TMC246, TMC249).....	7
4.4.1	Stepper Motor Driver (high resolution micro stepping).....	7
4.4.2	Stepper Motor Driver (low resolution micro stepping)	7
5	FUNCTIONAL BLOCKS AND REGISTERS	8
5.1	Ramp Generator	8
5.2	ABN Incremental Encoder Interface	8
5.2.1	Setting the encoder to match the motor resolution:.....	9
5.3	Vector control	9
5.3.1	Initialization of vector control mode	10
5.4	PID Controller - easyPID™	10
5.5	Step Direction Output Interface.....	11
5.6	Step Direction Input Interface for multi axis interpolation	11
5.7	Reference Switch and Stop Switch Interface.....	11
5.8	Micro Step Sequencer	11
5.8.1	ChopSync™ CHOPCLK	11
5.9	Type and Version Register / Version specific notes and known bugs.....	12
5.10	Interrupt Controller.....	12
5.11	Sine Wave Look-up Table (SIN-LUT) Access and Parameterization	13
5.11.1	Calculation of the Sine Wave Look-Up-Table to drive a Piezo Motor	13
5.11.2	Calculation of the Sine Wave Look-Up-Table to drive a Stepper Motor.....	13
6	REGISTER MAPPING	14
6.1	SPI Datagram Structure.....	14
6.1.1	Selection of Write / Read (WRITE_notREAD).....	14
6.1.2	Data Alignment	14
6.2	Register Block Structure – Register Mapping	14
6.2.1	Nomenclature of Read / Write / Clear on Read / Clear on Write of Registers	15
6.2.2	Time Scaling by Clock Frequency	15
6.2.3	Real World Units vs. Units of the TMC457	27
7	EXAMPLES	28
7.1	How to Get a Motor Running	28
7.2	Set Incremental Encoder Interface Parameters.....	28
8	NOTATION OF NUMBER SYSTEMS	29
9	PINNING, PACKAGE, AND ELECTRICAL DATA OF THE TMC457	30
9.1	Pinning of TMC457	30
9.1.1	Pull-Up / Pull-Down Resistances.....	33
9.1.2	Blocking Capacitors	33
9.2	Package Outlines and Dimensions	34

9.2.1	Fine Pitch BGA Package with 144 Balls (FBGA144) of TMC457-BC	34
10	MICRO CONTROLLER INTERFACE (SPI).....	35
11	CHARACTERISTICS	36
12	LITERATURE	37
13	REVISION HISTORY.....	37

2.1 Figures

Figure 1	: Functional Block Diagram of the TMC457	5
Figure 2	: TMC457 with Piezo Motor Interface.....	6
Figure 3	: High Resolution Micro Stepping Configuration	7
Figure 4	: Stepper Motor Driver Configuration (SPI)	7
Figure 5	: Outline of ABN Signals of an Incremental Encoder	8
Figure 6	: Incremental Encoder Signals Outline (AB w/o clear pulse N).....	29
Figure 7	: Package Outline Drawing FBGA144 – (JEDEC MO-192 VAR DAD-1)	34
Figure 8	: Timing Diagram of the Serial Micro Controller Interface	35
Figure 9	- General IO Timing Parameters	36

2.2 Tables

Table 1	: PWM frequency calculation for ChopSync™	12
Table 2	: TMC457-BC Pin Out.....	33
Table 3	: Dimensions of FBGA144 (Note: BSC = Basis Spacing Between Centers)	34
Table 4	: Timing Characteristics of the Micro Controller Serial Peripheral Interface (SPI)	35
Table 5	- Absolute Maximum Ratings	36
Table 6	– DC Characteristics Operating Conditions.....	36
Table 7	- Power Dissipation.....	36
Table 8	- General IO Timing Parameters	36

3 General Description

The TMC457 has been designed with TRINAMIC's background of more than 10 years of dedicated motion control ICs for stepper motors, like the 6 axis controller TMC406, the low cost 3 axis controller TMC428 and the high end controller TMC453 with its compatible successor TMC454. While there lie 10 years of development and experience between the TMC453 and the TMC457, the basic features look similar, but a lot of ideas, application know-how and customer feedback have been evaluated, sorted and flown into the design. The intention in creating the TMC457 was to provide a motion controller that provides superior performance, which can hardly be achieved by software in a processor system, while providing a very easy-to-use interface to the programmer, which looks similar to the peripherals found in a microcontroller. The electronic gear shift / pre-scaling found in our other motion controllers was eliminated by extending position and velocity registers to 32 bits. This direct control makes it easy to use the full range and precision of parameter setting. The easyPID™ closed loop PID regulator eases the achievement of control loop stability by providing a programmable hysteresis. Some features found in the TMC453 and TMC428 have been streamlined, to make them easier to use and some options have been removed, like the programmable sequencer for many different motor types, bearing in mind the most common applications.

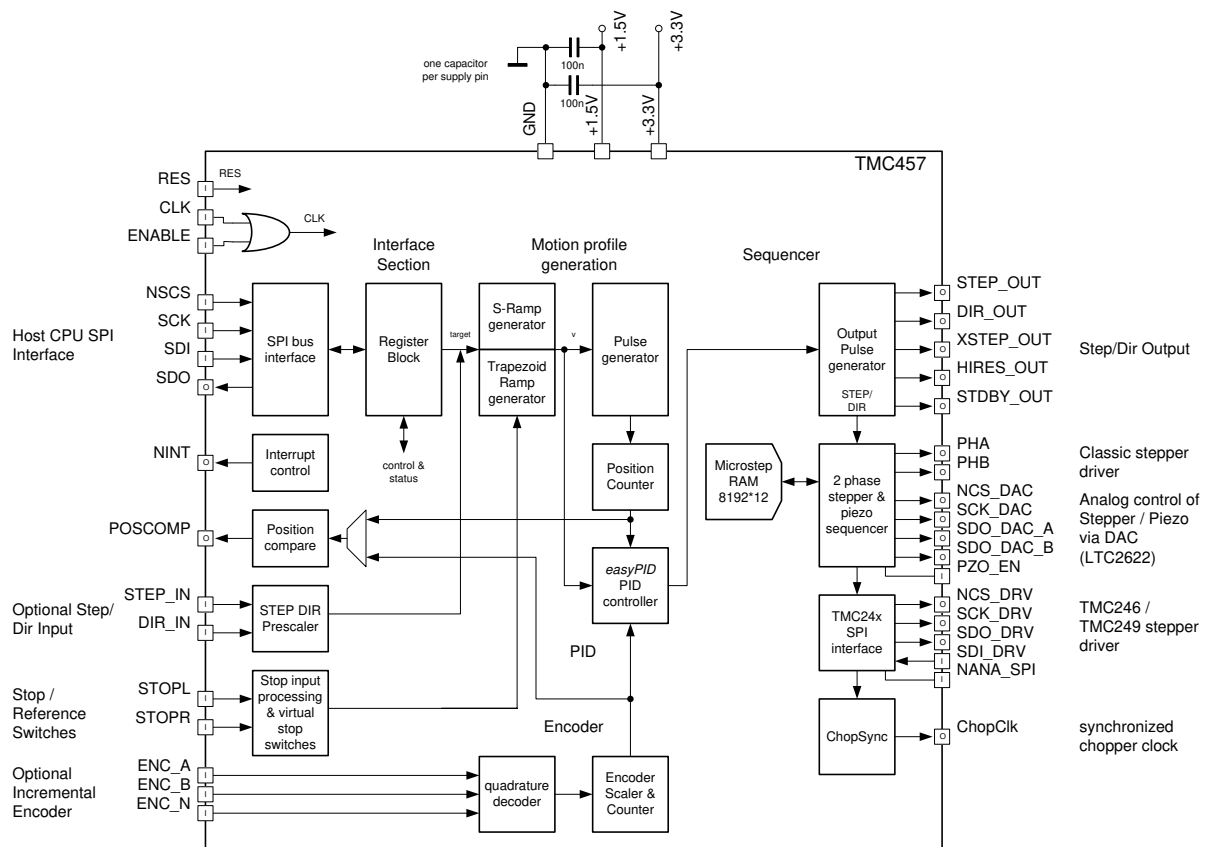

Figure 1 : Functional Block Diagram of the TMC457

4 TMC457 Block Diagram and Interfaces

Figure 1 shows the block diagram of the TMC457 motion controller. The TMC457 is equipped with a SPI interface for communication with the microcontroller. It uses a fixed data length of 40 bit – 8 bit address and 32 data. The TMC457 has a driver SPI to directly control the TRINAMIC stepper motor drivers TMC236, TMC239, TMC246, and TMC249. It supports processing of StallGuard information to emulate a reference switch, when using TMC246 or TMC249. The TMC457 has step direction input and step direction outputs as well to allow the control of step direction power stages (like the TMC332) or for external monitoring of motion by step pulse counting. For high precision micro stepping the TMC457 is equipped with a DAC interface for LTC2602. This allows control of the TMC236 family with extended microstep resolution or control of external power drivers with the classical analog control. An incremental encoder interface is added for processing incremental encoders with digital quadrature signal outputs (ABN). The position available from the quadrature signal decoder is directly available as an input for the PID position regulator. The PID regulator is for position stabilization also during motion. The PID regulator runs at an update rate of 100kHz and thus provides fastest response times.

4.1 Microcontroller Interface (SPI™)

The SPI for communication with the microcontroller to set motion control parameters (velocity, acceleration, bow, ...) of the TMC457 and to send motion command for positioning (set target position) and continuous motion applications (set velocity).

4.2 Step Direction Inputs

In addition to the SPI for micro controller communication with the TMC457, the motion can be controlled externally via the step direction inputs STEP_IN and DIR_IN.

4.3 DAC (LTC2602) Interface

The DAC interface directly controls LTC2602 from Linear Technologies to generate analog output signals (two channels for micro stepping of bipolar two phase stepper motors) and four channels as required for PiezoLEGS motors from the company Piezo-Motors.

4.3.1 Piezo Motor Driver

The power four required power stages of the driver for the piezoelectric motor (PiezoLEGS) must be able to drive a 100nF capacitance at 3kHz with an amplitude of 48V each. A power stage with these capabilities is realized for the TMC457 evaluation board.

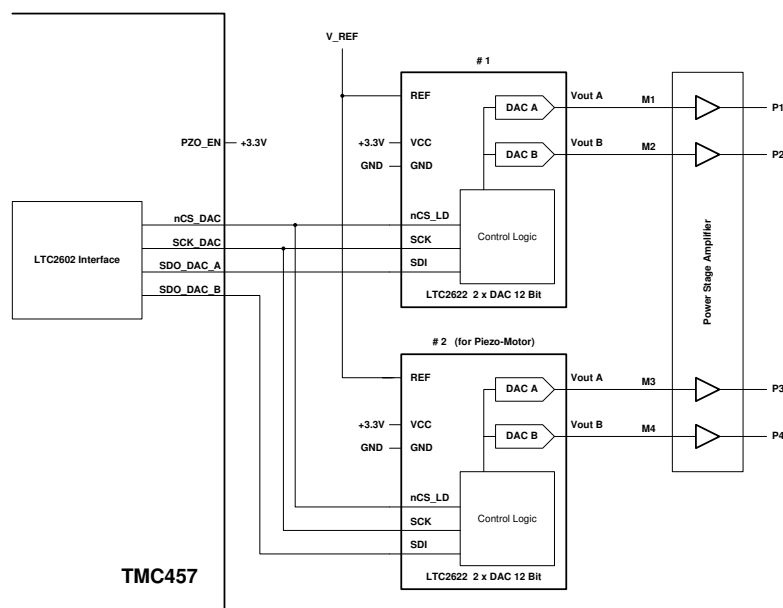

Figure 2 : TMC457 with Piezo Motor Interface

4.4 Stepper Motor Driver Interface (TMC236, TMC239, TMC246, TMC249)

The direct TRINAMIC driver interface of the TMC457 allows the TRINAMIC drivers to be controlled by the TMC457.

4.4.1 Stepper Motor Driver (high resolution micro stepping)

For high resolution micro stepping the TMC457 has an interface for dual SPI DAC LTC2602.

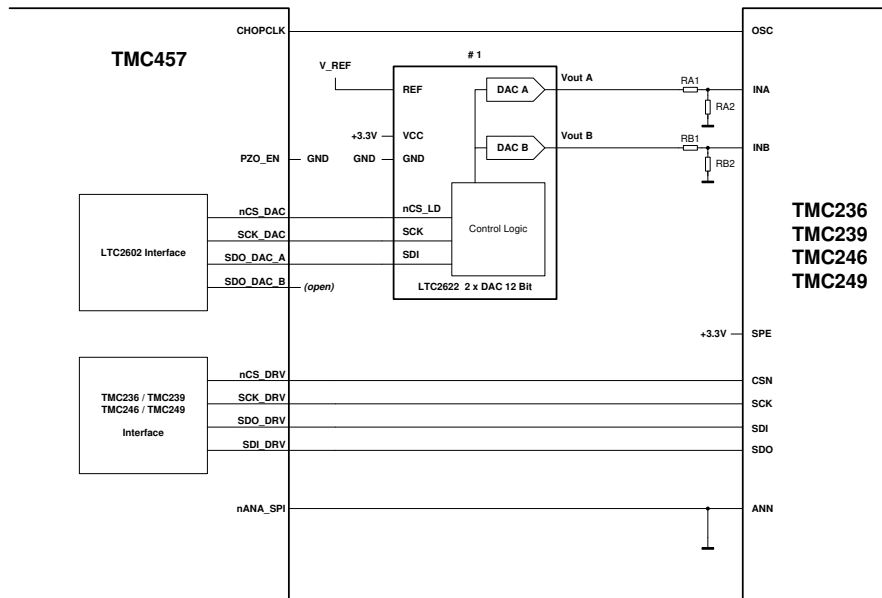

Figure 3 : High Resolution Micro Stepping Configuration

4.4.2 Stepper Motor Driver (low resolution micro stepping)

For low resolution micro stepping, a TRINAMIC driver can be connected directly via SPI without an additional DAC. With this, one can drive with 16 times micro stepping.

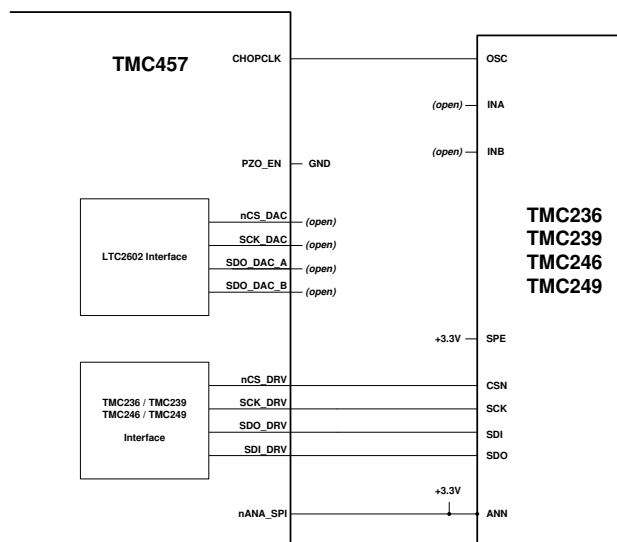

Figure 4 : Stepper Motor Driver Configuration (SPI)

5 Functional Blocks and Registers

5.1 Ramp Generator

The ramp generator is the heart of the motion controller. It runs either ramp with linear velocity profile or ramp with s-shape velocity profile. The selection is done by the bow parameter. Setting bow to 0 selects linear velocity profile. Linear ramps perform the quickest motion, by using the maximum available acceleration at all times. But, since the acceleration becomes switched on and off abruptly, system resonances can occur. They appear like an additional load on the motor, thus reducing the available useful portion of motor torque. Further, system resonances need some time to fade away, and this can cost valuable system time, if a complete stand still is required, before other actions can start. With the S-shaped ramp, resonances can be reduced. However, it is advised to choose the bow parameter as high as possible, in order to optimize positioning time.

The ramp generator provides four modes of operation:

[...]

It should be noted, that the choice of the microstep resolution directly influences the complete ramp generator parameter settings, because a higher microstep resolution means a higher end velocity setting, and thus a higher acceleration and a higher bow parameter to yield the same results. This way, the settings are scaled in a huge range, e.g. when changing between fullstep and highest resolution microstep.

Attention:

At all times, all parameters may be changed, but it should be noted, that unexpected results may occur, when changing the bow parameter to a lower value during an acceleration phase, or when changing the acceleration or deceleration parameter to a lower value. In these cases, the maximum positioning velocity, respectively the target position could be exceeded, in case the new values do not allow decelerating quickly enough. Even an overrun of the register value could occur and lead to unexpected results. Under normal circumstances, the bow parameter will be fixed in an application.

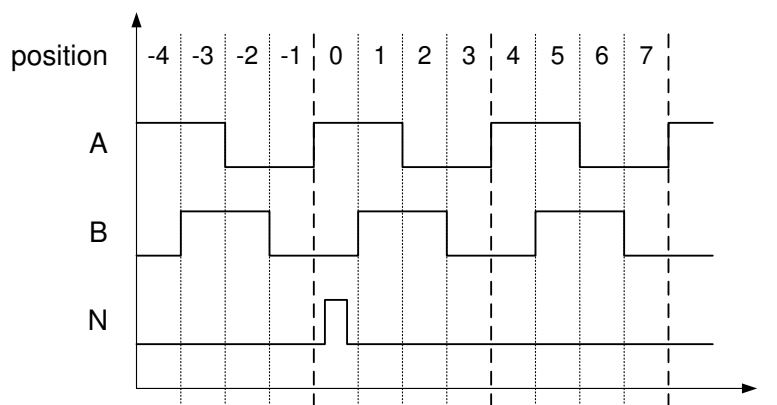

Figure 5 : Outline of ABN Signals of an Incremental Encoder

5.2 ABN Incremental Encoder Interface

The TMC457 is equipped with an incremental encoder interface for ABN encoders that gives positions via digital incremental quadrature signals (usually named A and B) and a clear signal (usually named N for null of Z for zero). The N signal can be used to clear a position. It might be necessary to disable the clearing of the encoder position after the first N signal event because the encoder gives this signal once for each revolution and for most applications a motor turns more than one revolution.

The encoder constant named *enc_const* is added or subtracted on each position change of the quadrature signals AB of the incremental encoder. The encoder constant *enc_const* represents an

unsigned fixed point number (16.16) to facilitate the generic adaption between motors and encoders. In decimal mode, the lower 16 bit represent a number between 0 and 9999. This is especially important for piezo motors (PiezoLEGS) because they do not have a fixed step length they achieve their very high positioning precision in the range of nanometers via closed loop control together with a position encoder. For stepper motors equipped with incremental encoders the fixed number representation allows very comfortable parameterization. Additionally, gear can easily be taken into account.

The encoder counter named `x_enc` holds the current determined encoder position. Different modes concerning handling of the signals A, B, and N take active low and active high signals of usual incremental encoders into account. For details please refer to the register mapping section 6 Register Mapping, page 14 ff.

The register `enc_status` holds the status concerning event of the ABN signals. The register `enc_latch` stores the actual encoder position on an N signal event. The register `x_latch` stores the position while a reference switch event occurs.

A register named `enc_warn_dist` (encoder warning distance) is used to generate an interrupt via the TMC457 interrupt controller if the distance between encoder position and actual position is larger then `enc_warn_dist`. The calculated error `pid_e` is available from the PID controller unit. Therefore, the PID controller needs to be enabled.

5.2.1 Setting the encoder to match the motor resolution:

Encoder example settings for motor parameters: 2048 μ steps, 200FS \rightarrow 409600 / U
Factor = FS \cdot μ S / encoder resolution

Encoder example settings for a 200 fullstep motor with 2048 microsteps		
Encoder resolution	required encoder factor	comment
200	2048	
360	1137,7778 = 74565404,4444 / 2 ¹⁶ = 11377777,7778 / 10000	No exact match possible!
500	819,2 = 53687091,2 / 2 ¹⁶ = 8192000 / 10000	exact match with decimal setting
1000	409,6	exact match with decimal setting
1024	400	
3600	113,7778	No exact match possible!
4000	102,4	exact match with decimal setting
4096	100	
8192	50	
16384	25	
32768	12.5	

5.3 Vector control

The vector control unit allows a load angle based motor control. This makes the motor behave like a servo motor, i.e. it can be overloaded or stopped, and will later on catch up again, using the PID regulator. Therefore, be careful to also activate the PID regulator!

Vector control is only possible using binary encoder resolutions, because no decimal setting is available. Low resolution decimal encoders still give a match.

Vector control example settings for a 200 fullstep motor		
Encoder resolution	required vector encoder factor	<i>venc_us_const</i>
512	25	1600
1024	12.5	800
2048	6.25	400
4096	3.125 = 3 1/8	200
8192	1.5625 = 1 9/16	100
16384	0.78125 = 25/32	50
32768	0.390625 = 25/64	25

A 400 fullstep motor needs the double setting

Different load angle limits above 90° allow for field weakening operation, which gives a faster motor operation.

5.3.1 Initialization of vector control mode

A precise initialization of the vector control mode is critical for best functionality. Also, the encoder needs to have an absolute precision, which is at least ½ fullstep of the motor.

For a newly assembled drive, an initial initialization is necessary. This initialization requires that the motor does not see any mechanical load during initialization. Later on, the vector control can be initialized with a stored offset from the initial initialization, using absolute position information, for example based on the encoder N channel.

For initial initialization, the following procedure can be followed:

The actual encoder position *venc_us_pos* needs to be initialized for vector control. The position must match selected *microstep_adr* bits, when the motor is unloaded in its exact position. This for example can be accomplished, by switching the motor to a high standby torque after power on. Directly after a power on, all *microstep_adr* bits are zero. Now, the motor will be in the exact zero position, as long as it sees no mechanical load. Therefore, now the *venc_us_pos* can be initialized with zero, in order to match the encoder angle to the electrical angle of the motor.

When the absolute position of the encoder is known, the vector control register *venc_us_pos* can be initialized based on this information. Therefore, the encoder needs to be read out, or the N channel needs to be found, and afterwards the stored offset can be added to the absolute position and be written to *venc_us_pos*. Be sure to do this in a high priority procedure, because the encoder should not advance a step in the meantime. If this cannot be guaranteed, a check and iteration should be done.

5.4 PID Controller - easyPID™

The PID (Proportional Integral Differential) controller calculates a velocity *v* based on a position difference error $pid_e = enc_x - x_actual$ where *enc_x* is the actual position- the real mechanical position -determined by the incremental encoder interface and *x_actual* is the actual position of the micro step sequencer –the position the TMC457 assumes to be the actual one. With this, the TMC457 moves with this (signed) velocity *v* until the actual position- measured by the incremental encoder – match. The velocity *v* to minimize the error *e* is calculated by

$$v = P \cdot e(t) + \int_0^t I \cdot e(t) \cdot dt + D \cdot \frac{d}{dt} e(t).$$

The motor moves with this velocity $v = pid_v_actual$ until the error *e(t)* vanishes resp. falls below a programmed limit – the hysteresis *pid_tolerance*. Primary, the PID regulator is parameterized by its basic parameter P, I, D represented by registers *pid_p*, *pid_i*, *pid_d*. Setting *pid_d* = 0 makes a PI regulator, additionally setting *pid_i* = 0 makes a P regulator. For micro controller interaction, the parameter *pid_dv_cpu* is added to the *pid_v_actual*. The readable register *pid_dv_clip* holds the actual value of clipping done by the PID controller of the TMC457.

Due to constraints of practical real world application, the integer part of the PID regulator can be clipped to a limit named `pid_iclip`. Without this, the integral part of the PID regulator `pid_isum` increases with each time step by `pid_i*pid_e` as long as the motor does not follow. The actual error can be read out from register `pid_e`. The integration over time of the error `e` is done with a fixed clock frequency of $f_{PID_INTEGRAL}[Hz] = f_{CLK}[Hz] / 128$. The time scaling for the deviation with respect to time of the error is controlled by the register named `pid_clk_div`.

A stabilization of the target position by programmable hysteresis is integrated to avoid oscillations of regulation when the actual position is close to the real mechanical position. The PID controller of the TMC457 is fast – programmable up to approximate 100kHz update rate at $f_{CLK} = 16$ MHz of the TMC457 – so that it can be used during motion to stabilize the motion. The parameterization of the PID controller of the TMC457 occurs in a direct way. Due to this, it is named easyPID™. Nevertheless, the parameterization of a PID controller might need a detailed knowledge of the application and the dynamic of the mechanics that is controlled by the PID controller. Additionally, a special control register allows software interaction for additional feedback control algorithms that can be implemented within the micro controller used to parameterize the TMC457.

5.5 Step Direction Output Interface

The TMC457 is equipped with step direction outputs (STEP, OUT). In Addition, it is equipped with a so called X_STEP output. A pulse on this output represents a number of (micro) steps. It is configured by the register named `pulse_xstep_div`. The TMC457 is able to generate step pulses with up to its clock frequency $f_{CLK}[Hz]$. Because a step frequency in the range of the clock frequency of the TMC457 might be too high for usual step direction drivers, an additional step output named X_STEP (extended step) is available. The X_STEP represents a number of steps to be done at a lower frequency. The threshold that selects between step pulses and extended step pulses is programmable. This can be parameterized to give full steps on the XSTEP output of the TMC457.

5.6 Step Direction Input Interface for multi axis interpolation

The TMC457 is equipped with step direction inputs (STEP_IN, DIR_IN). This allows using the TMC457 with an external ramp generator. A number of TMC457 can be synchronized by interconnecting the step direction inputs and outputs via a switch matrix. One TMC457 is used as master and its step and direction output is fed to the other TMC457. They can be programmed to follow the master pulses scaled by the 15 bit factor `sd_scale` (and sign). This way, multi-axis interpolation can be realized. The slave motion thus always is equal or slower than the master. When programming the master axis, the maximum allowed acceleration and velocity values of the slave axis have to be considered.

The step input is sampled once per system clock. Thus, the maximum input frequency is equal to the half system clock frequency. Please remark, that this also limits the master velocity during interpolated moves.

5.7 Reference Switch and Stop Switch Interface

The TMC457 is equipped with reference switch that can be programmed for automatic actions. For details please refer to the register mapping section 6 Register Mapping, page 14 ff. The reference switch inputs are available to store a position on a reference switch event. Additionally, these inputs can be enabled to force a stop.

5.8 Micro Step Sequencer

The micro step sequencer can be programmed for different micro step resolutions. The sequencer controls the mixed decay feature of TRINAMIC stepper motor drivers. Current scaling is also done under control of the sequencer. When using TMC246 or TMC249 the StallGuard™ threshold is under control of the sequencer. A readable register holds the TRINAMIC stepper motor driver status bits and diagnosis bits.

5.8.1 ChopSync™ CHOPCLK

To use the ChopSync™ feature together with a TRINAMIC stepper motor driver the output CHOPCLK of the TMC457 has to be connected to the PWM oscillator input OSC of the TRINAMIC stepper motor driver (TMC236, TMC239, TMC246, or TMC249) – without a capacitor at the OSC input. The recommended chopper frequency f_{OSC} for the TRINAMIC stepper motor driver is

36kHz. The chopper frequency should not be below 25kHz and must be lower than 50kHz. The chopper frequency is programmed via the register `chop_clk_div`.

Warning: A chopper clock signal with a too high frequency might damage the stepper motor driver due to dynamic power dissipation overload.

fCLK[Hz]	fOSC[Hz]	chop_clk_div	
16.000.000	36.000	0x1BC	(=444)
	25.000	0x280	(=640)
8.000.000	36.000	0x0DE	(=222)
	25.000	0x140	(=320)
fCLK[Hz]	fOSC[Hz]	fCLK[Hz] / fOSC[Hz]	

Table 1 : PWM frequency calculation for ChopSync™

5.9 Type and Version Register / Version specific notes and known bugs

The type of the controller and its version can be read out from a register. For the TMC457 version 1.02 one gets 0x00457102 reading the type and version register. This allows hardware detection. Reading the version allows handling of different version by a single software version.

Version	Bug	Description and workaround
1.02	AMAX lower limit with linear ramps	<p>When using linear ramps, setting AMAX to a value lower than 128 results in a strange positioning behavior, when AMAX and DMAX differ.</p> <p>This is due to an internal rounding which results in AMAX being used for deceleration rather than DMAX or vice versa.</p> <p>This bug will be corrected in future versions.</p> <p>Workaround:</p> <p>Use AMAX values above 128, when AMAX and DMAX are required to be different. AMAX values below 128 are typically only required, when working with low microstepping resolutions.</p> <p>Alternative: Use S-shaped ramps.</p>
-1.03	Stop switches do not become disabled at move in opposite direction while actual velocity is zero	<p>When the motor becomes stopped by a stop switch, a movement into the opposite direction is not possible without disabling the stop switch.</p> <p>The reason is that the stop switches are active in any direction when velocity is zero.</p> <p>This bug will be corrected in future versions.</p> <p>Workaround:</p> <p>Disable stop switch when moving into opposite direction.</p>

5.10 Interrupt Controller

The interrupt controller is programmable for different conditions. If an interrupt condition occurs the open drain output `nINT` is pulled to low (activated) if the interrupt mask for the corresponding interrupt condition is enabled.

5.11 Sine Wave Look-up Table (SIN-LUT) Access and Parameterization

The TMC457 is equipped with an internal RAM (8192 addresses x 12 bit data) to hold a sine wave look-up table for micro stepping. This look-up table has to be initialized first after power up of the TMC457. Depending on the type of motor, a dedicated sine wave table has to be written into the internal RAM of the TMC457. For both, 8192 values of 12 bit integer have to be calculated. The sine LUT RAM is accessed via two register addresses, one for read and one for write.

Important Hint: When reading data from RAM, the read data are valid with the next read access. So, the read data are pipelined with a delay of one SPI datagram.

5.11.1 Calculation of the Sine Wave Look-Up-Table to drive a Piezo Motor

$$y(x) = 4096 + 4095 * \sin(2\pi * x/8192 - 2*\pi/8) \text{ with } x = 0, 1, 2, 3, \dots, 8189, 8190, 8191.$$

5.11.2 Calculation of the Sine Wave Look-Up-Table to drive a Stepper Motor

$$y(x) = \text{abs}(4095 * \sin(2\pi * x/8192)) \text{ with } x = 0, 1, 2, 3, \dots, 8189, 8190, 8191.$$

With offset, to adjust current zero crossing, the formula becomes

$$y(x) = \text{offset} + \text{abs}((4095 - \text{offset}) * \sin(2\pi * x/8192)) \text{ with } x = 0, 1, 2, 3, \dots, 8189, 8190, 8191.$$

The offset has a theoretical range of 0 to 4094. For a practical application, the offset will lie between 0 and 100. When using current scaling, the offset also becomes scaled down – this may be needed to be taken into account!

6 Register Mapping

6.1 SPI Datagram Structure

The TMC457 uses 40 Bit SPI™ (Serial Peripheral Interface, SPI is Trademark of Motorola) datagrams for communication with a microcontroller. Microcontrollers which are equipped with hardware SPI are typically able to communicate with integer multiples of 8 bit.

Each datagram sent to the TMC457 is composed of an address byte followed by four data bytes. This allows direct 32 bit data word communication with the register set of the TMC457. Each register is accessed via 32 data bits even if it uses less than 32 data bits.

For simplification, each register is specified by a one byte address, where the reading address is given with the most significant bit = '0'. For a write access, the most significant bit of the address byte is '1'. Most registers are write only registers, some can be read additionally, and there are also some read only registers.

6.1.1 Selection of Write / Read (WRITE_notREAD)

The read and write selection is controlled by the MSB of the address byte (bit 39 of the SPI datagram). This bit is '0' for read access and '1' for write access. So, the bit named W is a WRITE_notREAD control bit. The active high write bit is the MSB of the address byte. So, 0x80 has to be added to the address for a write access.

Example: For a read access to the register (x_actual) with the address 0x01, the address byte has to be set to 0x01. For a write access to the register (x_actual) with the address 0x01, the address byte has to be set to 0x80 + 0x01 = 0x81. For read access, the data bit might have any value ('-'). So, one can set them to '0'.

READ x_actual datagram ⇔ 0x01000000000;
 WRITE x_actual := 0x89ABCDEF; datagram ⇔ 0x8189ABCDEF;

TMC457 SPI Datagram Structure																																																	
MSB (transmitted first)								40 bit								LSB (transmitted last)																																	
39 0																													
8 bit ADDRESS								32 bit DATA																																									
39 ... 32								31 ... 0																																									
RW + 7 bit ADDRESS								8 bit DATA				8 bit DATA				8 bit DATA				8 bit DATA																													
39 / 38 ... 32								31 ... 24				23 ... 16				15 ... 8				7 ... 0																													
w	38...32							31...28				27...24				23...20				19...16				15...12				11...8				7...4				3...0													
3	3	3	3	3	3	3	3	3	3	2	2	2	2	2	2	2	2	1	1	1	1	1	1	1	1	1	1	1	1	9	8	7	6	5	4	3	2	1	0	9	8	7	6	5	4	3	2	1	0

6.1.2 Data Alignment

All data are right aligned. Some registers represent unsigned (positive) values, some represent integer values (signed) as two's complement numbers, single bits or groups of bits are represented as single bits respectively as integer groups.

6.2 Register Block Structure – Register Mapping

All parameterizations take place by register writes. The access to the registers is via SPI. The ramp generator register set enfolds basic motion control parameters, a ramp generator register set, an incremental encoder register set, a PID controller register set – named easyPID™, a step direction output configuration register set, a reference switch configuration register set, a micro step sequencer configuration register, a type & version register, an interrupt configuration register, and a sine wave look-up table (LUT) RAM port register.

6.2.1 Nomenclature of Read / Write / Clear on Read / Clear on Write of Registers

Units are written in are given in brackets, e.g. [micro steps]. Read only registers are designated by R. Read only registers with automatic clear (C) on read are designated by R+C. Registers that are cleared on write are designated by W+C. Write only registers are designated by W.

6.2.2 Time Scaling by Clock Frequency

Time is scaled by the the clock frequency of the TMC457. This scales velocity, acceleration, and bow. So, velocity is given in unit [micro steps per time] and not as [micro steps per second], acceleration is given in unit [micro steps per time²] and not unit [micro steps per second²]. Formulas for the conversion into units based on time in seconds is given in section 0, page 27.

Ramp Generator Register Set – Basic Motion Control Parameters					
R/W	Addr	Bits	Register	Description	Range [Unit]
RW	0x00	9...0	<i>mode</i>	bit 1,0: <i>ramp_mode</i> 00 = positioning mode 01 = reserved 10 = velocity mode 11 = hold mode	default = %0000000010
				bit 2: <i>step_dir_enable</i>	
				bit 4: <i>shaft</i>	
				bit 8: <i>PID_on</i>	
				bit 9: <i>PID_base v_actual</i>	
RW	0x01	31...0	<i>x_actual</i>	Actual position	± [μsteps]
R	0x02	31...0	<i>v_actual</i>	Actual velocity	± [μsteps / t]
W	0x03	30...0	<i>v_max</i>	Maximum velocity for positioning mode	0 to \$7FFF0000 for any <i>a_max</i> [μsteps / t]
W	0x04	31...0	<i>v_target</i>	Target velocity The sign determines the direction in velocity mode and hold mode.	± \$7FFF0000 for any <i>a_max</i> [μsteps / t]
W	0x05	23...0	<i>a_max</i>	Acceleration, unsigned fixed point 16.8 representation	0 to \$FFFFFFD [μsteps / t ²]
W	0x06	23...0	<i>d_max</i>	Deceleration parameter, unsigned Fixed point 16.8 representation The effective deceleration with s-ramp enabled is 15/16 of <i>d_max</i> .	0 to \$FFFFFFD [μsteps / t ²]
W	0x07	23...0	<i>d_stop</i>	Deceleration for stop event, for security reason it is with <i>bow</i> = 0	[μsteps / t ²]
W	0x08	4...0	<i>bow_max</i>	S-Ramp configuration 0=linear ramp (trapezoid) <i>bow_index</i> = 1, 2, 3, ..., 18 ⇔ <i>bow_value</i> = 1, 2, 4, ..., 262144	<i>bow_value</i> [μsteps / t ³]
W	0x09	31...0	<i>x_target</i>	Target position for automatic ramp in unit micro steps	± [μsteps]
W	0x0A	31...0	<i>x_compare</i>	POSCOMP output function: The position <i>x_compare</i> is compared either with <i>x_actual</i> or with the encoder position <i>enc_x</i> . (Selection bit: <i>enc_clr_mode</i> .12.) POSCOMP becomes 0 : for <i>x_actual</i> ≤ <i>x_compare</i> 1 : for <i>x_actual</i> > <i>x_compare</i>	± [μsteps]
R	0x0B	4...0	<i>status</i>	bit 0: <i>target_pos_reached</i>	
				bit 1: <i>target_v_reached</i>	
				bit 2: <i>v_is_zero</i>	
				bit 3: - (reserved)	
				bit 4: <i>enc_warn_dist</i>	
R	0x0C	31...0	<i>a_actual</i>	Actual acceleration value Important note: <i>a_max</i> resp. <i>d_max</i> can be exceeded by up to 1/1024 of the <i>bow_value</i> if 1/1024* <i>bow_value</i> is not an integer divider of <i>a_max</i> resp. <i>d_max</i>	0, ..., ± <i>a_max</i> resp. <i>d_max</i> resp. <i>d_stop</i> ; [μsteps / t ²]
W	0x0D	15...0	<i>sd_scale</i>	Step Direction input control:	dir & c (c⇔accumulation constant-1)
				bit 14...0: <i>sd_scaler</i> bit 15: <i>sd_scale_sign</i>	
	0x0E	-	-	reserved	
W	0x0F	23...0	<i>a_max_d_max</i>	Sets <i>a_max</i> and <i>d_max</i> to the same value with a single write access to register <i>a_max_d_max</i>	[μsteps / t ²]

0x00: <i>mode</i> - Ramp Generator Register				
R/W	Bit	Function	Value	Description
RW	1,0	<i>ramp_mode</i>	00	positioning mode
			01	reserved
			10	velocity mode (default mode on RESET)
			11	hold mode (sets <i>v_actual</i> equal to <i>v_target</i>)
RW	2	<i>step_dir_enable</i>	0	step direction inputs are ignored
			1	The step and direction inputs (STEP_IN, DIR_IN) become scaled by <i>sd_scale</i> . In this mode, <i>x_target</i> becomes directly controlled by the scaled step inputs. In order to allow the motor to directly follow the control signals, set to positioning mode and set a high acceleration value <i>a_max_d_max</i> with <i>bow</i> set to zero.
RW	4	<i>shaft</i>	0	Normal direction of the output pulse generator
			1	Inverts the direction of the output pulse generator
RW	8	<i>PID_on</i>	0	PID controller is completely off, all values are frozen. The output pulse generator is fed by <i>v_actual</i> directly.
			1	PID controller is on. This mode also allows access to the PID error <i>pid_e</i> , which is required for a number of other functions. For normal operation, also set <i>PID_base</i> flag to <i>v_actual</i> base.
RW	9	<i>PID_base</i>	0	The pulse generator output is controlled by the PID calculation result only. The motor will not move, if PID result is zero.
			1	PID output base is <i>v_actual</i> . The PID result is added to the velocity output generated by the ramp generator and becomes clipped to $2^{31}-1$.

0x08: <i>bow_max</i> - Ramp Generator Register				
R/W	Bit	Function	Value	Description
W	4...0	<i>bow_index</i>	0	The ramp generator uses trapezoid ramps. This corresponds to an infinite <i>bow</i> value.
			1 to 18	Bow for s-shaped ramps in logarithmic representation. A high <i>bow</i> value leads to a shorter <i>bow</i> phase. The <i>bow_value</i> is added with $1/1024 f_{CLK}[\text{Hz}]$ to acceleration <i>a_actual</i> up to the value set by <i>a_max</i> for acceleration resp. <i>d_max</i> for deceleration. $bow_value = 2^{(bow_index-1)}$ <i>bow_index</i> = 1, 2, 3, ..., 18 ⇔ <i>bow_value</i> = 1, 2, 4, ..., 262144 Attention on bow setting: The resulting <i>bow_value</i> must not exceed <i>A_MAX</i> or <i>D_MAX</i> setting. Otherwise oscillations may result.

0x0b: status - Ramp Generator Register				
R/W	Bit	Function	Value	Description
R	0	<i>target_pos_reached</i>	1	Signals that the motor has stopped at the target position ($x_{actual}=x_{target}$), or at a position determined by <i>PositionLimit L</i> or <i>PositionLimit R</i> .
	1	<i>target_v_reached</i>	1	Signals that v_{actual} has reached v_{target} , respectively v_{max} during an automatic ramp.
	2	<i>v_is_zero</i>	1	Signals that the motor has stopped.
	3	-	-	Unused (reserved)
	4	<i>enc_warn_dist_status</i>	1	Signals that the deviation between encoder position and actual ramp position exceeds the warning threshold <i>enc_warn_dist</i> .

0x0D: <i>sd_scale</i> - Ramp Generator Register				
R/W	Bit	Function	Value	Description
W	14...0	<i>sd_scaler</i>	x	Each step input pulse counts up resp. down <i>x_target</i> by $(x+1) / (2^{15})$
	15	<i>sd_scale_sign</i>	0	Count up when direction input is positive
			1	Count down when direction input is positive

Encoder Register Set					
R/W	Addr	Bits	Register	Description	Range [Unit]
W	0x10	31...0	<i>enc_const</i>	Accumulation constant, 16 bit integer part, 16 bit fractional part <i>enc_x</i> accumulates $\pm enc_const / (2^{16} * enc_x)$ (binary) or $\pm enc_const / (10^4 * enc_x)$ (decimal) To switch between decimal and binary setting, see <i>enc_mode</i> bit 13. Use the sign, to match rotation direction!	binary: $\pm [\mu\text{steps}/2^{16}]$ $\pm(0...32767.0...65535)$ decimal: $\pm(0...32767.0...9999)$ default = 1.0 (=65536)
RW	0x11	31...0	<i>enc_x</i>	Actual encoder position	$\pm [\mu\text{steps}]$
W	0x12	12...0	<i>enc_mode</i>	bit 0 : <i>pol_A</i> bit 1 : <i>pol_B</i> bit 2 : <i>pol_N</i> bit 3 : <i>ignore_AB</i> bit 4 : <i>clr_cont</i> bit 5 : <i>clr_once</i> bit 6 : <i>pos_edge</i> bit 7 : <i>neg_edge</i> bit 8 : <i>clr_enc_x</i> bit 12 : <i>x_comp_sel_enc</i> bit 13 : <i>enc_sel_decimal</i>	
R+C	0x13	0	<i>enc_status</i>	bit 0 : <i>N_event</i> Encoder N event detected, status bit is cleared on read: Read (R) + clear (C)	
R	0x14	31...0	<i>enc_latch</i>	Encoder position <i>enc_x</i> latched on N event	$[\mu\text{steps}]$
R	0x15	31...0	<i>x_act_latch</i>	Motor position <i>x_actual</i> latched on reference switch event or virtual stop switch event	$[\mu\text{steps}]$
W	0x16	19...0	<i>enc_warn_dist</i>	Warning threshold for motor to encoder deviation ($x_actual - enc_x$). This function uses <i>pid_e</i> . An interrupt can be triggered when the threshold is exceeded. $abs(pid_e) > enc_warn_dist$	$[\mu\text{steps}]$

0x12: <i>enc_mode</i> - Encoder Register				
R/W	Bit	Function	Value	Description
	0	<i>pol_A</i>	x	A polarity when N is active
	1	<i>pol_B</i>	x	B polarity when N is active
	2	<i>pol_N</i>	x	defines polarity of N
	3	<i>ignore_AB</i>	x	Ignore A and B polarity
	4	<i>clr_cont</i>	1	continuous clear while N is active (clear once per revolution)
	5	<i>clr_once</i>	1	N event enable, clear on next N event
	6	<i>pos_edge</i>	1	N positive edge trigger (when N becomes active) Disables N level control
	7	<i>neg_edge</i>	1	N negative edge trigger (when N becomes inactive) Disables N level control
	8	<i>clr_enc_x</i>	0	Upon N event, the <i>enc_x</i> becomes latched to <i>enc_latch</i> only
			1	Additionally clear encoder counter <i>enc_x</i> at N-event
	9	-	-	- (reserved)
	10	-	-	- (reserved)
	11	-	-	- (reserved)
	12	<i>x_comp_sel_enc</i>	0	Source for POSCOMP: <i>x_compare</i> is compared to <i>x_actual</i>
			1	<i>x_compare</i> is compared to <i>enc_x</i>
	13	<i>enc_sel_decimal</i>	0	Encoder divisor binary: Counts in n/65536
			1	Encoder divisor decimal: Counts in n/10000

Vector Control Register Set					
R/W	Addr	Bits	Register	Description	Range [Unit]
W	0x17	11...0	<i>venc_us_const</i>	Accumulation constant, 6 integer part, 6 bit fractional part $venc_us_const = 64 * (\text{motor full steps per rotation}) / \text{encoder resolution}$ 0.0: vector control off Use the sign, to match rotation direction!	\pm [μ steps/64] default = 0 (off)
RW	0x18	7...0	<i>venc_us_pos</i>	Actual encoder position (use for initialization of function – position must match selected <i>microstep_adr</i> bits)	[256 / electrical period]
W	0x19	9...8, 1...0	<i>venc_us_sel</i>	bit 0,1 : <i>venc_microstep_resolution</i> 00 = 2048 microsteps 01 = 1024 microsteps 10 = 256 microsteps 11 = 64 microsteps selects bits from <i>microstep_adr</i> (0x33) to match one electrical period bit 8, 9 : <i>venc_phi_load_sel</i> 00 = 90° 01 = 101,25° 10 = 112,5° 11 = 121,75° selects maximum motor load angle	

0x19: <i>venc_us_sel</i> – Vector Control Register				
R/W	Bit	Function	Value	Description
W	1, 0	<i>venc_us_sel</i>	00	2048 microsteps: <i>microstep_adr</i> bits 12 down to 5 are used to determine angle within one electrical period
			01	1024 microsteps: <i>microstep_adr</i> bits 11 down to 4 are used to determine angle within one electrical period
			10	256 microsteps: <i>microstep_adr</i> bits 9 down to 2 are used to determine angle within one electrical period
			11	64 microsteps: <i>microstep_adr</i> bits 7 down to 0 are used to determine angle within one electrical period
	9, 8	<i>venc_phi_load_sel</i>	00	vector encoder function load angle limit to +/- 90° (64/256 of an electrical period) (max. torque)
			01	+/- 101.25° (72/256 of an electrical period)
			10	+/- 112,5° (80/256 of an electrical period)
			11	+/- 123,75° (88/256 of an electrical period) (max. velocity)

PID Register Set - easyPID™					
R/W	Addr	Bits	Register	Description	Range
W	0x20	23...0	<i>pid_p</i>	P parameter (unsigned) update frequency $f_{CLK}/128$; Result: $pid_e * pid_p / 256$ (becomes clipped to +/- 2 ³¹)	(0: disable)
W	0x21	23...0	<i>pid_i</i>	I parameter (unsigned) Result: $(pid_{isum}/256) * pid_i / 256$ (becomes clipped to +/- 2 ³¹)	(0: disable)
W	0x22	23...0	<i>pid_d</i>	D parameter (unsigned), <i>pid_e</i> is sampled with a frequency of $(f_{CLK}[Hz]/128/pid_d_clkdiv)$. Result: $(pid_e_last - pid_e_now) * pid_d$ (The delta-error ($pid_e_last - pid_e_now$) becomes clipped to +/- 127)	(0: disable)
W	0x23	14...0	<i>pid_iclip</i>	Clipping parameter for <i>pid_isum</i> Clipping of $(pid_{isum} * 2^{16} * pid_iclip)$	0...\$7F80
R W+C	0x24	31...0	<i>pid_isum</i>	PID integrator sum (signed) Updated with $f_{CLK}[Hz]/128$ Cleared to zero upon write access	±
W	0x25	7...0	<i>pid_d_clkdiv</i>	Clock divider for D part calculation D-part is calculated with a frequency of: $f_{CLK} / (pid_d_clkdiv * 128)$ (Attention: <i>pid_d_clkdiv</i> =0 results in 256)	1...255, 0 = 1...256
W	0x26	-	-	-	-
W	0x27	30...0	<i>pid_dv_clip</i>	Clipping parameter for PID calculation result pid_v_actual $pid_v_actual = v_actual + clip(PID_result, pid_dv_clip)$	bits 7...0 are always 0 (0: disable PID)
R	0x28	23...0 (31...0)	<i>pid_e</i>	Position deviation (for monitoring) $pid_e = enc_x - x_actual$ (clipped to +/- 2 ²³)	±2 ²³
R	0x29	31...0	<i>pid_v_actual</i>	PID calculation result (with <i>PID_base</i> =0) resp. $PID_result + v_actual$ (<i>PID_base</i> =1) (clipped to +/- 2 ³¹)	±
W	0x2A	19...0	<i>pid_tolerance</i>	Tolerance for PID regulation If the absolute value of the error <i>pid_e</i> is below <i>pid_tolerance</i> after an exact hit, then the <i>pid_error_in</i> becomes 0 and <i>pid_i_sum</i> is set to zero, until the	

				tolerance zone is left again.	
--	--	--	--	-------------------------------	--

Step Direction Output Configuration Register Set					
R/W	Addr	Bits	Register	Description	Range
W	0x30	28...0	<i>pulse_max</i>	Velocity threshold for resolution indication output HIRES_OUT If $v_{actual} \geq pulse_max$ then output HIRES = 1 The driver stage can do extended steps based on XSTEP_OUT	bits 20...0 are always 0
W	0x31	15...0	<i>pulse_xstep_div</i>	Pulse divisor for XSTEP_OUT output control One XSTEP_OUT pulse is generated after each <i>pulse_xstep_div</i> steps	1...65535 default=16
W	0x32	0	<i>step_dir_mode</i>	0: disable STEP_OUT delay 1: enable STEP_OUT delay after a change of the direction (DIR_OUT) (It is recommended to disable the delay, unless a step / direction drive is used)	
RW	0x33	12...0	<i>microstep_adr</i>	Actual micro step position within look-up table	
W	0x34	11...0	<i>stdby_delay</i>	Stand-by delay, time is given in $1/f_{CLK} / 2^{16}$	
W	0x35	7...0	<i>pulse_length</i>	Pulse length in clock periods for STEP_OUT and XSTEP_OUT outputs (DIR_OUT remains stable during STEP_OUT active, XSTEP_OUT occurs 2 clock periods later)	

Reference Switch Configuration Register Set					
R/W	Addr	Bits	Register	Description	Range
RW	0x40	13...0	<i>switch_mode</i>	bit 0: <i>stop_L</i>	
				bit 1: <i>stop_R</i>	
				bit 2: <i>pol_stop_L</i>	
				bit 3: <i>pol_stop_R</i>	
				bit 4: <i>swap_LR</i>	
				bit 5: <i>soft_stop</i>	
				bit 6: <i>en_lim_L</i>	
				bit 7: <i>en_lim_R</i>	
				bit 8: <i>latch_L_act</i>	
				bit 9: <i>latch_L_inact</i>	
				bit 10: <i>latch_R_act</i>	
				bit 11: <i>latch_R_inact</i>	
				bit 12: <i>en_latch_enc</i>	
				bit 13: <i>SG_stop</i>	
R, R+C	0x41	6...0	<i>switch_status</i>	bit 0 : <i>status_stop_L</i>	
				bit 1 : <i>status_stop_R</i>	
				bit 2 : <i>status_latch_L</i>	
				bit 3: <i>status_latch_R</i>	
				bit 4: <i>event_stop_L</i>	
				bit 5: <i>event_stop_R</i>	
				bit 6: <i>event_stop_SG</i>	
W	0x42	31...0	<i>pos_limit_L</i>	Software controlled stop position, programmable virtual stop switch If enabled, the motor will automatically slow down and come to a stop at the <i>pos_limit</i> rather than crossing it.	
W	0x43	31...0	<i>pos_limit_R</i>	Software controlled stop position, programmable virtual stop switch If enabled, the motor will automatically slow down and come to a stop at the <i>pos_limit</i> rather than crossing it.	

0x40: <i>switch_mode</i> – Reference Switch Configuration Register				
R/W	Bit	Function	Value	Description
R/W	0	<i>stop_L</i>	1	Enable stop switch left
	1	<i>stop_R</i>	1	Enable stop switch right
	2	<i>pol_stop_L</i>	0	Left stop switch is positive active (STOP_L=1 stops motor)
			1	Left stop switch is negative active (STOP_L=0 stops motor)
	3	<i>pol_stop_R</i>	0	Right stop switch is positive active (STOP_R=1 stops motor)
			1	Right stop switch is negative active (STOP_R=0 stops motor)
	4	<i>swap_LR</i>	0	STOP_L stops motor when driving in negative direction, STOP_R stops motor when driving in positive direction
			1	Stop inputs are swapped: STOP_R stops motor when driving in negative direction, STOP_L stops motor when driving in positive direction
	5	<i>soft_stop</i>	0	The motor velocity is switched to 0 when hitting a stop switch (hard stop).
			1	SoftStop enable: The motor is slowed down to 0 using a linear ramp using acceleration <i>d_stop</i> when hitting a stop switch.
	6	<i>en_lim_L</i>	1	Position limit L <i>pos_limit_L</i> enable (virtual stop switch)
	7	<i>en_lim_R</i>	1	Position limit R <i>pos_limit_R</i> enable (virtual stop switch)
	8	<i>latch_L_act</i>	1	Latch ramp position to <i>x_act_latch</i> on stop switch left going active.
	9	<i>latch_L_inact</i>	1	Latch ramp position to <i>x_act_latch</i> on stop switch left going inactive.
10	<i>latch_R_act</i>	1	Latch ramp position to <i>x_act_latch</i> on stop switch right going active.	
11	<i>latch_R_inact</i>	1	Latch ramp position to <i>x_act_latch</i> on stop switch right going inactive.	
12	<i>en_latch_enc</i>	0	Encoder position is not latched upon stop switch event.	
		1	Also latch encoder position together with ramp position to <i>enc_latch</i> .	
13	<i>stop_SG</i>	1	Stop motor on StallGuard event signaled by TMC246 / TMC249	

0x41: <i>switch_status</i> – Reference Switch Configuration Register				
R/W	Bit	Function	Value	Description
R	0	<i>status_stop_L</i>	1	Stop switch left status (1=active)
	1	<i>status_stop_R</i>	1	Stop switch right status (1=active)
R+C	2	<i>status_latch_L</i>	1	Latch left ready (corresponding to <i>switch_mode latch_L_act</i> or <i>latch_L_inact</i>) (Flag is cleared upon reading)
	3	<i>status_latch_R</i>	1	Latch right ready (corresponding to <i>switch_mode latch_R_act</i> or <i>latch_R_inact</i>) (Flag is cleared upon reading)
R	4	<i>event_stop_L</i>	1	Signals an active stop left condition due to stop switch
	5	<i>event_stop_R</i>	1	Signals an active stop right condition due to stop switch
R+C	6	<i>event_stop_SG</i>	1	Signals an active StallGuard stop event (Flag is cleared upon reading)

Sequencer Configuration Register					
R/W	Addr	Bits	Register	Description	Range
	0x50		- (reserved)		
	0x51		- (reserved)		
	0x52		- (reserved)		
	0x53		- (reserved)		
RW	0x54	8...0	<i>seq_mode</i>	bit 3...0: microstep table length Controls the number of microsteps per electrical period. For a stepper motor, the resulting microstep rate is 1/4 of the table length. Values: 0: 8192 entries (Default), 1: 4096 entries, ... 10: 8 entries, 11: 4 entries (full stepping) bit 8: sequencer stop	
W	0x55	23...0	<i>dacscale_icntl</i>	bit 0..4: <i>current_op</i> bit 7: <i>mixdecay_op</i> bit 8..12: <i>current_sb</i> bit 15: <i>mixdecay_sb</i>	default=% 00000000 00000000 10010000
W	0x56	2...0	<i>stallguard_thrs</i>	StallGuard threshold	0...7
R		2...0	<i>stallguard_value</i>	actual StallGuard value reported by TMC249	0...7
R	0x57	2...0	<i>driver_status</i>	Driver status read back information: bit 0 : <i>tmcdrv_error</i> (OT, UV, OCHS, OCB, OCA. i.e. all driver shutdown conditions) bit 1 : <i>tmcdrv_otpw</i> (over temperature pre-warning) bit 2 : <i>tmcdrv_stall</i> (StallGuard)	
	0x58		- (reserved)		
W	0x59	11...0	<i>chop_clk_div</i>	chopper clock frequency register (for safety reasons a value below 96 can not be set)	96...818 default = 640

0x55: <i>dacscale_icntl</i> – Sequencer Configuration Register				
R/W	Bit	Function	Value	Description
W	4...0	<i>current_op</i>	0...16	Motor current scale during operation (Default=16) Allows a current scaling by scaling the sine table entries before sending to the DACs or to the SPI stepper drivers. This function is available only for stepper motors. 16 = 100% 15...1 = 15 / 16 ... 1 / 16 0 = DAC disable / stepper driver disable
	7	<i>mixdecay_op</i>	1	Mixed Decay Enable Operation (Default = 1) Enables the TMC23X / TMC24X mixed decay feature during motor operation.
	12...8	<i>current_sb</i>	0...16	Standby current scale (Default=0) The motor is switched to the standby current after a delay time controller by <i>stdby_delay</i> . Same values as for <i>current_op</i> .
	15	<i>mixdecay_sb</i>	1	Mixed Decay Enable Standby (Default=0) Enables the TMC23X / TMC24X mixed decay feature during motor stand still.

Type & Version Register					
R/W	Addr	Bits	Register	Description	Range
R	0x60	23...0	<i>version</i>	TMC457 v. 1.00 ⇔ 0x457100	

Interrupt Configuration Register					
R/W	Addr	Bits	Register	Description	Range
W	0x61	7...0	<i>int_mask</i>	bit 0: <i>int_target</i>	
				bit 1: <i>int_deviation</i>	
				bit 2: <i>int_N</i>	
				bit 3: <i>int_stop</i>	
				bit 4: <i>int_drvstatus</i>	
				bit 5: <i>int_ref_L</i>	
				bit 6: <i>int_ref_R</i>	
				bit 7: <i>int_x_comp</i>	
R W+C	0x62	7...0	<i>int_flag</i>	Same assignments as <i>int_mask</i> register. An active interrupt bit reads out as '1'. Writing a 1 to an active bit resets the interrupt flag. The interrupt output becomes active (low) as soon as at least one bit is set.	

0x61: <i>int_mask</i> – Interrupt Configuration Register					
R/W	Bit	Function	Value	Description	
W	0	<i>int_target</i>	1	Target position reached interrupt: If set, an interrupt is issued when the motor comes to a standstill at <i>x_target</i>	
	1	<i>int_deviation</i>	1	Encoder position mismatch interrupt: If set, an interrupt is issued, when <i>pid_e</i> exceeds the tolerance value <i>pid_tolerance</i> .	
	2	<i>int_N</i>	1	Encoder N event interrupt : If set, an interrupt is issued upon an encoder N event, as defined by <i>enc_clr_mode</i> .	
	3	<i>int_stop</i>	1	Stop condition interrupt: If set, an interrupt is issued upon a motor stop condition, as defined by <i>switch_mode</i> .	
	4	<i>int_drvstatus</i>	1	Driver status interrupt: If set, an interrupt is issued upon a driver error detected in the <i>driver_status</i> bits.	
	5	<i>int_ref_L</i>	1	Reference switch left interrupt: If set, an interrupt becomes issued upon activation of the left reference switch.	
	6	<i>int_ref_R</i>	1	Reference switch right interrupt: If set, an interrupt is issued upon activation of the right reference switch.	
	7	<i>int_x_comp</i>	1	POSCOMP (<i>x_compare</i>) change interrupt: If set, an interrupt is issued, when the polarity of the POSCOMP output changes. <i>Attention:</i> For a move right, this is when <i>x_actual</i> (resp. <i>enc_x</i>) becomes larger than <i>x_compare</i> , i.e. reaches <i>x_compare</i> +1. For a move left, it is upon position match! <i>Attention:</i> Modifying the compare position also will trigger the interrupt flag and will toggle the output, when the comparison result differs.	

Sine Wave Look-Up Table (LUT) Port Register					
R/W	Addr	Bits	Register	Description	Range
R	0x7F	31...16 15...0	RAM	READ (data D of last A)	xxxAAAAAAAAAAAAA xxxxDDDDDDDDDDDD (data of this address come on next read)
W	0xFF	31...16 15...0	RAM	WRITE	xxxAAAAAAAAAAAAA xxxxDDDDDDDDDDDD

6.2.3 Real World Units vs. Units of the TMC457

The units of a TMC457 register content are written as register[457].

Parameter vs. Units		
Parameter / Symbol	Unit	calculation / description / comment
f_{CLK} [Hz]	[Hz]	clock frequency of the TMC457 in [Hz]
s	[s]	second
US	microstep	
FS	fullstep	
velocity v [Hz]	microsteps / s	$v[Hz] = v[457] * (2 * f_{CLK}[Hz] / 2^{31})$
acceleration a [Hz/s]	microsteps / s ²	$a[Hz/s] = a[457] * f_{CLK}[Hz]^2 / (16*256) / 2^{30}$
micro step resolution USR (used U instead of μ for micro)	counts	micro step resolution in number of microsteps (i.e. the number of microsteps between two fullsteps)
$v[FS]$ @ USR	US/s	$v[FS/s] = v[US/2] / USR$ USR \leftrightarrow microstep resolution
$a[FS/s^2]$ @ USR	US/s ²	$a[FS/s^2] = a[US/s] / USR$
ramp_steps[457] = rs	[457]	$rs = 2 * (v[457])^2 / (a[457]) / 2^{18}$ micro steps during linear acceleration ramp (if v_{max} is really reached during acceleration)

7 Examples

Following, some examples are given how to program the TMC457 to do a desired task. The examples are given as sequences of SPI datagram as 40 bit hexadecimal number with an additional comment.

```
$89 12 34 56 78 // set x_target := $12 34 56 78
```

So, for this example the datagram is \$89 12 34 56 78. That datagram sets the register x_target to the hexadecimal value \$12345678.

7.1 How to Get a Motor Running

// initialize the sine wave look-up table **once** (either for stepper motor or for piezo motor).

```
for (x=0; x<8192; x++)
{
  y = abs( 4095 * sin(2.0 * 3.141592652 * x / 8192) ); // stepper motor
  datagram = ( 0x7F << 32 ) | ( x << 16 ) | ( y ); // compose datagram
}
```

This results in a sequence of datagramms for initializing the sine wave look-up table as:

```
$FF $00 $00 $00 $00 // ram[ 0] := 0x0000;
$FF $00 $01 $00 $03 // ram[ 1] := 0x0003;
$FF $00 $02 $00 $06 // ram[ 2] := 0x0006;
.
.
$FF $1F $FD $00 $09 // ram[8189] := 0x0009;
$FF $1F $FE $00 $06 // ram[8190] := 0x0006;
$FF $1F $FF $00 $03 // ram[8191] := 0x0003;
```

// now the motion //

```
$80 xx xx xx xx // mode := %00 = ramp_mode positioning mode with linear ramps
$83 xx xx xx xx // v_max := $xx xx xx xx
$88 00 00 00 00 // bow_max := 0 = linear ramp
$8F xx xx xx xx // a_max_d_max := $xx xx xx xx
$89 00 BC 61 4E // x_target := 12345678; => move to target position x_target
```

7.2 Set Incremental Encoder Interface Parameters

For this example, we assume to have an incremental encoder with a resolution of 16384 steps per revolution. For the quadrature signals A and B this means that they toggle 8192 times per revolution with a phase shift of quarter period.

A stepper motor is assumed to have 200 full steps per revolution and is driven with a micro step revolution of 256 micro steps per full step. So, for this example, the stepper motor has $200 * 256 = 51200$ micro steps per revolution.

The axis of the incremental encoder is assumed to be directly connected to the axis of the stepper motor with a gear. With this, a number of 16384 positions of the incremental encoder are equal to 51200 micro steps of the stepper motor.

So, each position count of the encoder is equal to $51200 / 16384 = 3.125$ micro steps.

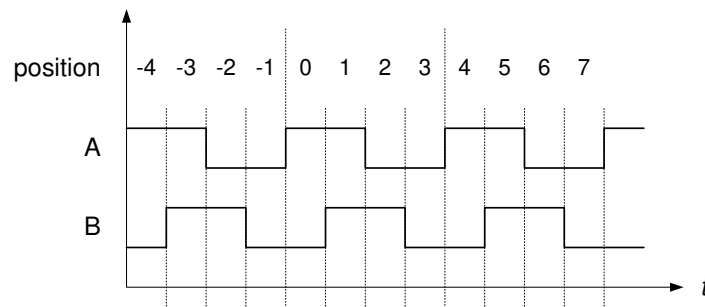

Figure 6 : Incremental Encoder Signals Outline (AB w/o clear pulse N)

So, the accumulation constant **enc_const** of the incremental encoder interface of the TMC457 has to be set that each encoder step represents 3.15. This is achieved by setting $\text{enc_const} = 3.125 * 65536 = 204800 = \$00\ 03\ 20\ 00$. The datagram sequence doing the initialization of the encoder interface is:

```

$90 00 03 20 00      // set enc_const := $00 03 20 00

$91 00 03 20 00      // set x_enc := $00 00 00 00
$92 00 03 20 00      // set enc_clr_mode := $00 00 00 00, ignore N pulse

```

8 Notation of Number Systems

Decimal numbers are used as usual without additional identification. Binary numbers are identified by a prefixed % character. Hexadecimal numbers are identified by a prefixed \$ character. Alternatively, hexadecimal numbers are identified similar to C language with a prefixed 0x. For better readability of long number spaces are inserted. So, for example the decimal number 42 in the decimal system is written as %101010 in the binary number system, and it is written as \$2A or 0x2A in the hexadecimal number system.

9 Pinning, Package, and Electrical data of the TMC457

9.1 Pinning of TMC457

The TMC457-BC is available within a 144 ball fine pitch (1 mm) BGA package.

Important Hints:

All pins specified as (n.c. = not connect) *must* be left unconnected (open). All power supply pins (named V33 for +3.3V and named V15 for +1.5V) and all ground pins *must* be connected.

All inputs and all outputs have 3.3V CMOS level. Level shifters are required when using 5V devices (e.g. micro controller with 5V IO, incremental encoder with 5V ABN outputs, ...).

Other unnamed pins have to be left open. Pins with comment "do not connect (must not be connected)" must be left open because these are unused but driving outputs.

#	BGA Ball	Signal Name	In/Out	Description / Comment
1	A1	GND		ground
2	A2	V33		+3.3V supply voltage
3	A3	-	n.c.	do not connect (must not be connected)
4	A4	-	n.c.	do not connect (must not be connected)
5	A5	DIR_IN	I	direction input
6	A6	GND		ground
7	A7	-		
8	A8	V15		+1.5V supply voltage
9	A9	-	n.c.	do not connect (must not be connected)
10	A10	STEP_IN	I	step input
11	A11			
12	A12	GND		ground
13	B1	CLK	I	clock input
14	B2	GND		ground
15	B3			
16	B4	POSCOMP	O	position comparator output signal (pls. refer x_compare)
17	B5	ENC_A	I	A signal from incremental encoder (ABN) for 3.3V level
18	B6			
19	B7			
20	B8	-	n.c.	do not connect (must not be connected)
21	B9	-	n.c.	do not connect (must not be connected)
22	B10			
23	B11	GND		ground
24	B12	V33		+3.3V supply voltage
25	C1	nEN	I	clock gating input, logical ored with CLK, must be connected to ground
26	C2	RES	I	active high reset input
27	C3			
28	C4	V15		+1.5V supply voltage
29	C5	ENC_B		B signal from incremental encoder (ABN) for 3.3V level
30	C6			
31	C7			
32	C8	-	n.c.	do not connect (must not be connected)

33	C9	-	n.c.	do not connect (must not be connected)
34	C10	PZO_EN	I	piezo motor enable (0:stepper motor / 1:piezo motor)
35	C11	SDO_DAC_A	O	SDO for LTC2602 DAC A input SDI
36	C12	SDO_DAC_B	O	SDO for LTC2602 DAC B input SDI
37	D1	SCK	I	SPI clock input from microcontroller
38	D2	nINT	o.C./O	active low interrupt output (open drain)
39	D3			
40	D4			
41	D5	ENC_N	I	N signal from incremental encoder (ABN) for 3.3V level
42	D6			
43	D7			
44	D8	-	n.c.	do not connect (must not be connected)
45	D9			
46	D10			
47	D11			
48	D12			
49	E1	V15		+1.5V supply voltage
50	E2			
51	E3			
52	E4	V33		+3.3V supply voltage
53	E5			
54	E6	V33		+3.3V supply voltage
55	E7	V33		+3.3V supply voltage
56	E8			
57	E9	V33		+3.3V supply voltage
58	E10	V15		+1.5V supply voltage
59	E11			
60	E12			
61	F1	nSCS	I	chip select input for microcontroller interface
62	F2	GND		ground
63	F3			
64	F4		n.c.	do not connect (must not be connected)
65	F5	GND		ground
66	F6	GND		ground
67	F7	GND		ground
68	F8			
69	F9			
70	F10	GND		ground
71	F11			
72	F12	SCK_DAC	O	serial clock for LTC2602 DAC
73	G1			
74	G2	GND		ground
75	G3		n.c.	do not connect (must not be connected)
76	G4			
77	G5	GND		ground
78	G6	GND		ground
79	G7	GND		ground
80	G8			
81	G9			
82	G10			
83	G11			

84	G12	NCS_DAC	O	chip select for LTC2602 DAC
85	H1	V15		+1.5V supply voltage
86	H2			
87	H3			
88	H4			
89	H5	V15		+1.5V supply voltage
90	H6	unused output	O	
91	H7	unused output	O	
92	H8	unused output	O	
93	H9			
94	H10	V33		+3.3V supply voltage
95	H11			
96	H12	V15		+1.5V supply voltage
97	J1			
98	J2			
99	J3	V33		+3.3V supply voltage
100	J4			
101	J5	PHA	O	phase A polarity output (for stepper motors)
102	J6	CHOPCLK	O	ChopSync™ PWM clock signal output for TRINAMIC stepper motor driver OSC input (TMC236, TMC239, TMC246, TMC249)
103	J7	V15		+1.5V supply voltage
104	J8	(TCK)	I	can be left open with VJTAG tied to GND
105	J9			
106	J10	(TDO)	TRST/O	can be left open with VJTAG tied to GND
107	J11			
108	J12	STOPL	I	stop switch left
109	K1	SDI	I	serial data input, driven by micro controller output MOSI
110	K2	SDO	TRST/O	serial data output, drives micro controller input MISO
111	K3			
112	K4	HIRES_OUT	O	high resolution control output (optional use) 0 : low resolution (use higher step width mode, XSTEP or full step mode), 1 : high resolution (use micro stepping)
113	K5	PHB	O	phase B polarity output (for stepper motors)
114	K6	SCK_DRV	O	serial data clock signal to stepper motor driver
115	K7	GND		ground
116	K8			
117	K9			
118	K10	GND		ground
119	K11			
120	K12	STOPR	I	stop switch right
121	L1	GND		ground
122	L2	V33		+3.3V supply voltage
123	L3	DIR_OUT	O	direction output
124	L4	STDBY_OUT	O	stand-by output signal to lower standby current of driver
125	L5	V33		+3.3V supply voltage
126	L6	SDO_DRV	O	serial data output to stepper motor driver
127	L7			
128	L8			
129	L9	(TMS)		can be left open with VJTAG tied to GND
130	L10	(VJTAG)		ground to disable JTAG
131	L11	V33		+3.3V supply voltage

132	L12	(TRST)	I	ground to disable JTAG
133	M1	GND		ground
134	M2	STEP_OUT	O	step output
135	M3	XSTEP_OUT	O	extended step output (lower frequency)
136	M4	nANA_SPI	I	SPI / not analog input selects type of stepper driver control (0: use external DAC, 1: use TMC236 internal DAC)
137	M5	nCS_DRV	O	serial data selection signal to stepper driver
138	M6	SDI_DRV	I	serial data input from stepper driver
139	M7			
140	M8			
141	M9	(TDI)		can be left open with VJTAG tied to GND
142	M10	V33		+3.3V supply voltage
143	M11	PDR	I	connect this input via 1K pull-down resistor to ground
144	M12	GND		ground

Table 2: TMC457-BC Pin Out

9.1.1 Pull-Up / Pull-Down Resistances

Some inputs have weak on-chip pull-up resp. weak pull-down resistors. The resistance of these is within the range of 10 kOhm (min.) ... 45 kOhm (max.)

9.1.2 Blocking Capacitors

Ceramic capacitors of 100nF capacitance should be connected as close as possible at each 1V5 power supply pin and at each 3V3 power supply pin. Alternatively, two power planes – one power plane for +1V5 (V15) and one power plane for +3V3 (V33) can be used.

9.2 Package Outlines and Dimensions

9.2.1 Fine Pitch BGA Package with 144 Balls (FBGA144) of TMC457-BC

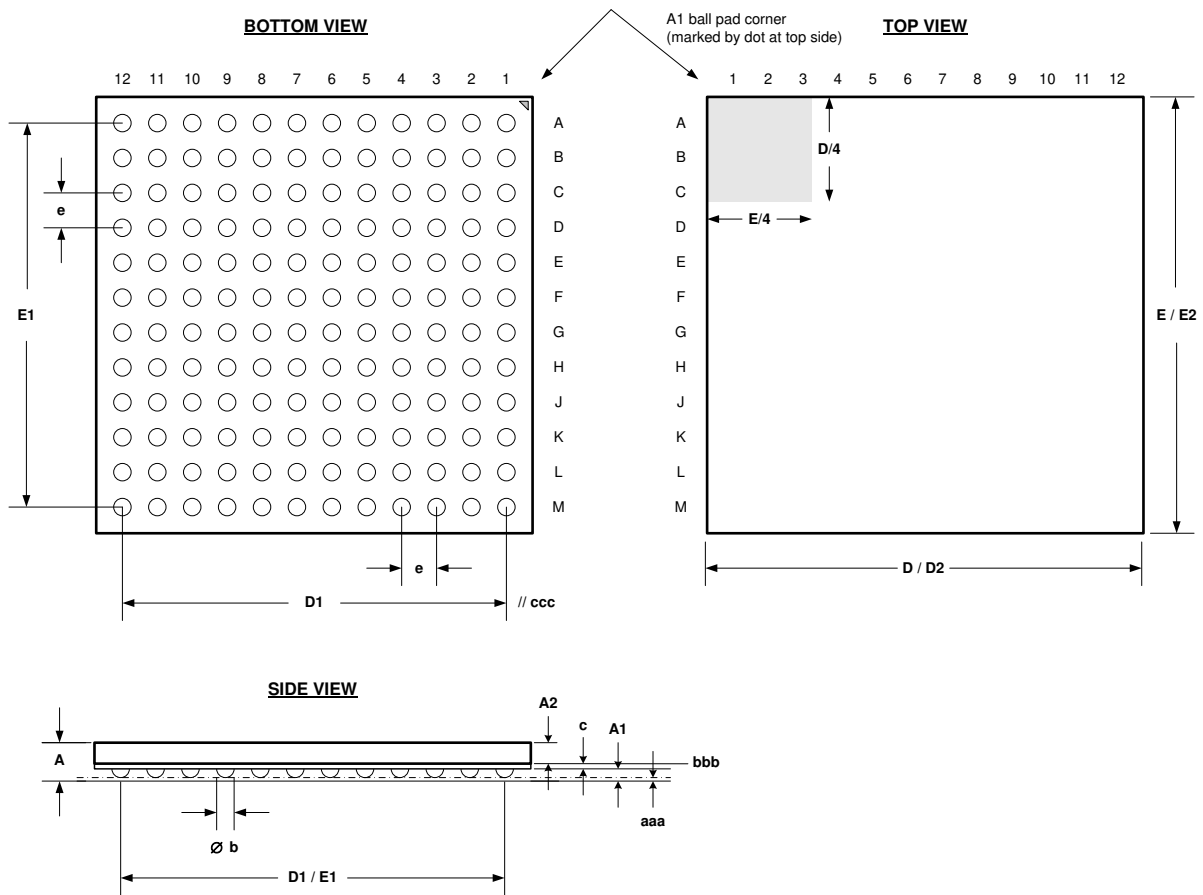

Figure 7 : Package Outline Drawing FBGA144 – (JEDEC MO-192 VAR DAD-1)

Symbol	Dimensions in MILLIMETERS			Dimensions in INCHES		
	Min	Typ	Max	Min	Typ	Max
A	1.35	1.45	1.55			
A1	0.35	0.40	0.45			
A2	0.65	0.70	0.75			
aaa		0.12				
b	0.45	0.50	0.55			
bbb		0.25				
c	-	0.35	-			
ccc		0.35				
D	12.80	13.00	13.20			
D1	11.00 BSC					
D2	12.80	13.00	13.20			
E	12.80	13.00	13.20			
E1	11.00 BSC					
E2	12.80	13.00	13.20			
e		1.00				

Table 3 : Dimensions of FBGA144 (Note: BSC = Basis Spacing Between Centers)

10 Micro Controller Interface (SPI)

The communication between micro controller and TMC457 takes place via the four via serial interface, the Serial Peripheral Interface (SPI™, SPI is trademark of Motorola). Many types of micro controllers of different vendors are equipped with SPI hardware.

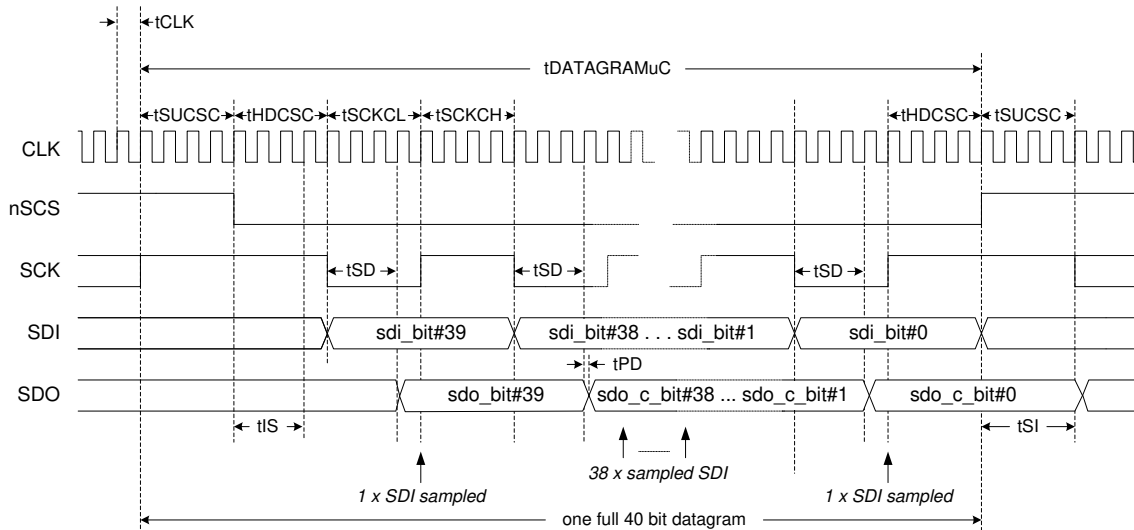

Figure 8 : Timing Diagram of the Serial Micro Controller Interface

Symbol	Parameter	Min	Typ	Max	Unit
tSUCSC	Setup Clocks for nSCS	3		∞	CLK periods
tHDCSC	Hold Clocks for nSCS	3		∞	CLK periods
tSCKCL	Serial Clock Low	3		∞	CLK periods
tSCKCH	Serial Clock High	3		∞	CLK periods
tSD	SDO valid after SCK low	2.5		3.5	CLK periods
tSI	SDO valid after nSCS high			4.5	CLK periods
tDAMAGRAMuC	Datagram Length	$3+3 + 40*6 = 246$		∞	CLK periods
tDAMAGRAMuC	Datagram Length	12.3		∞	μs
fCLK	Clock Frequency	0		20	MHz
tCLK	Clock Period tCLK = 1 / fCLK	50		∞	ns
tPD	CLK-rising-edge-to-Output Propagation Delay		5		ns

Table 4: Timing Characteristics of the Micro Controller Serial Peripheral Interface (SPI)

11 Characteristics

Symbol	Parameter	Conditions	Min	Max	Unit
VCORE_AMR	core supply voltage		-0.3	1.65	V
VOI_AMR	IO supply voltage		-0.3	3.75	V
VIN_AMR	input voltage	3.3V IO supply voltage VIO	-0.3	3.6	V

Table 5 - Absolute Maximum Ratings

Symbol	Parameter	Conditions	Min	Typ	Max	Unit
TCOM	commercial temperature range		0		70	°C
VCORE	nominal core voltage			1.5		V
VIO	nominal IO voltage			3.3		V
VIN	nominal input voltage		0.0		3.3	V
VINL	input voltage low level	85°C (test condition)	-0.3		0.8	V
VINH	input voltage high level	85°C (test condition)	2.0		3.6	V
VOUTL	output voltage low level	85°C (test condition)			0.4	V
VOUTH	output voltage high level	85°C (test condition)	2.4			V
IOUTDRV	output driver strength	85°C (test condition)		12		mA

Table 6 – DC Characteristics Operating Conditions

Symbol	Parameter	Conditions	Min	Typ	Max	Unit
PDST	static power dissipation	25°C		15		mW
PDDY	dynamic power dissipation	25°C, 16 MHz		75		mW
PD	total power dissipation	25°C, 16 MHz		90		mW

Table 7 - Power Dissipation

Symbol	Parameter	Conditions	Min	Typ	Max	Unit
fCLK	Operation Frequency	fCLK = 1 / tCLK			20	MHz
tCLK	Clock Period	Raising Edge to Raising Edge of CLK			50	ns
tCLK_L	Clock Time Low		25			ns
tCLK_H	Clock Time High		25			ns
tRISE_I	Input Signal Rise Time	10% to 90%		5		ns
tFALL_I	Input Signal Fall Time	90% to 10%		5		ns
tRISE_O	Output Signal Rise Time	10% to 90%		5		ns
tFALL_O	Output Signal Fall Time	90% to 10%				ns
tSU	Setup Time	relative to falling clock edge at CLK		5		ns
tHD	Hold Time	relative to falling clock edge at CLK		5		ns
tPD	Propagation Delay Time	50% of rising edge of the clock CLK to 50% of the output		30		ns

Table 8 - General IO Timing Parameters

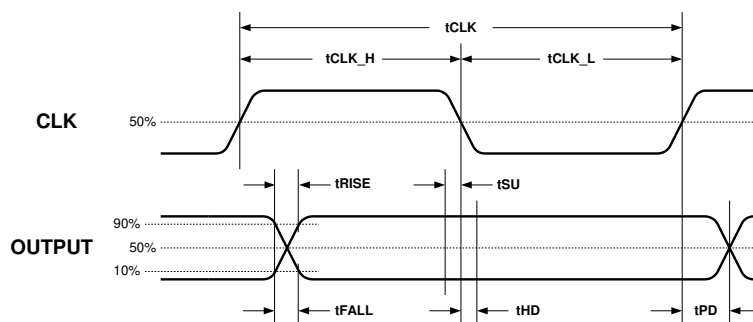

Figure 9 - General IO Timing Parameters

12 Literature

LTC2602 Datasheet, www.linear.com

TMC236 Datasheet, www.trinamic.com

TMC239 Datasheet, www.trinamic.com

TMC246 Datasheet, www.trinamic.com

TMC249 Datasheet, www.trinamic.com

PiezoMotor, www.piezomotor.se

PiezoLEGS® Technology Information, <http://www.piezomotor.se/pages/PLtechnology.html>

PiezoLEGS® Datasheets, <http://www.piezomotor.se/pages/PLdownloads.html>

13 Revision History

Version	Date (LL=Dr. Lars Larsson BD=Bernhard Dwersteg)	Description
1.00	25.08.2008 (LL)	First published version
1.01	30.10.2008 (LL)	Formula for calculation of sine wave look-up table corrected (section 5.11.2, page 13 and section 7.1, page 28).
1.02	03.10.2008 (LL)	load_scale outputs added at pinning table and register mapping (section 9, page 30 ff. & section 6.2, page 14 ff.)
1.06	27.10.2008 (BD)	Detail tables for registers with complex content, added some missing register bits
1.07	04.01.2009 (LL, BD)	formula for calculation of sine wave look-up table corrected (section 5.11.2, page 13) and calculation of look-up table with offset added, corrected acceleration formula
1.08	19.01.2009 (LL)	Pin F4 in Table 2: TMC457-BC Pin Out, page 33 corrected (n.c. instead of ground)
1.09	26.03.2009 (BD)	Reference Switch table corrected (Reference Switch Configuration Register Set)
1.10	31.03.2009 (BD)	Changed documentation for Version 1.02 of TMC457 : <ul style="list-style-type: none"> Added vector encoder registers (venc...) Attention: VENC functions are only available starting from V1.02 of TMC457! Register PID_DV_CPU was removed; register bits current_scale and outputs LOAD_SCALE were removed, Actual TMC249 stallguard value can be read now Encoder constant can now be scaled in 1/10000 steps (enable via bit 13 of enc_mode) enc_clr_mode register renamed to enc_mode
1.11	22.04.2009 (BD)	Added bow restrictions, corrected formula for bow value (Bernhard Dwersteg 40 th birthday version!)
1.12	12.06.2009 (BD)	Improved some descriptions
1.13	07.09.2009 (LL, BD)	Pin G3 (75) explicitly marked as n.c. / F1 is input / Corrected pinning table according names in Fig.1
1.14	09.09.2009 (BD)	C4 is GND, new method to disable JTAG by tying L10 and L12 to GND
1.15	05.10.2009 (LL, BD)	C4 is a +1V5 (correct in pinning table, but comment in history 1.14 needed adaption) V1.02 of TMC457: linear ramp failure when AMAX<128 and AMAX/=DMAX Added known bugs section
1.16	25.11.2009 (BD)	Documented wrong stop switch behavior, corrected in V1.04 of TMC457.
1.17	06.01.2010 (BD)	Corrected x_compare interrupt functional description, wrong venc_us formula
1.18	16.03.2010 (BD)	Minor changes in example code
1.19	19.01.2011 (LL)	Example section 7.1 How to Get a Motor Running, p. 28 corrected according to correct calculation described in section 5.11.2 Calculation of the Sine Wave Look-Up-Table to drive a Stepper Motor, p. 13.

Please refer to www.trinamic.com for updated data sheets and application notes on this product and on other products.

The TMCtechLIB CD-ROM including data sheets, application notes, schematics of evaluation boards, software of evaluation boards, source code examples, parameter calculation spreadsheets, tools, and more is available from TRINAMIC Motion Control GmbH & Co. KG by request to tmc_info@trinamic.com