

THIS DRAWING IS UNPUBLISHED. RELEASED FOR PUBLICATION
 © COPYRIGHT copyright.d8Te- ALL RIGHTS RESERVED.

REVISIONS					
P	LTR	DESCRIPTION	DATE	DWN	APVD
	A	NEW DRAWING	14SEP2016	RS	ML
	A1	REVISED PER ECR-16-016988	03JAN2017	RK	PO

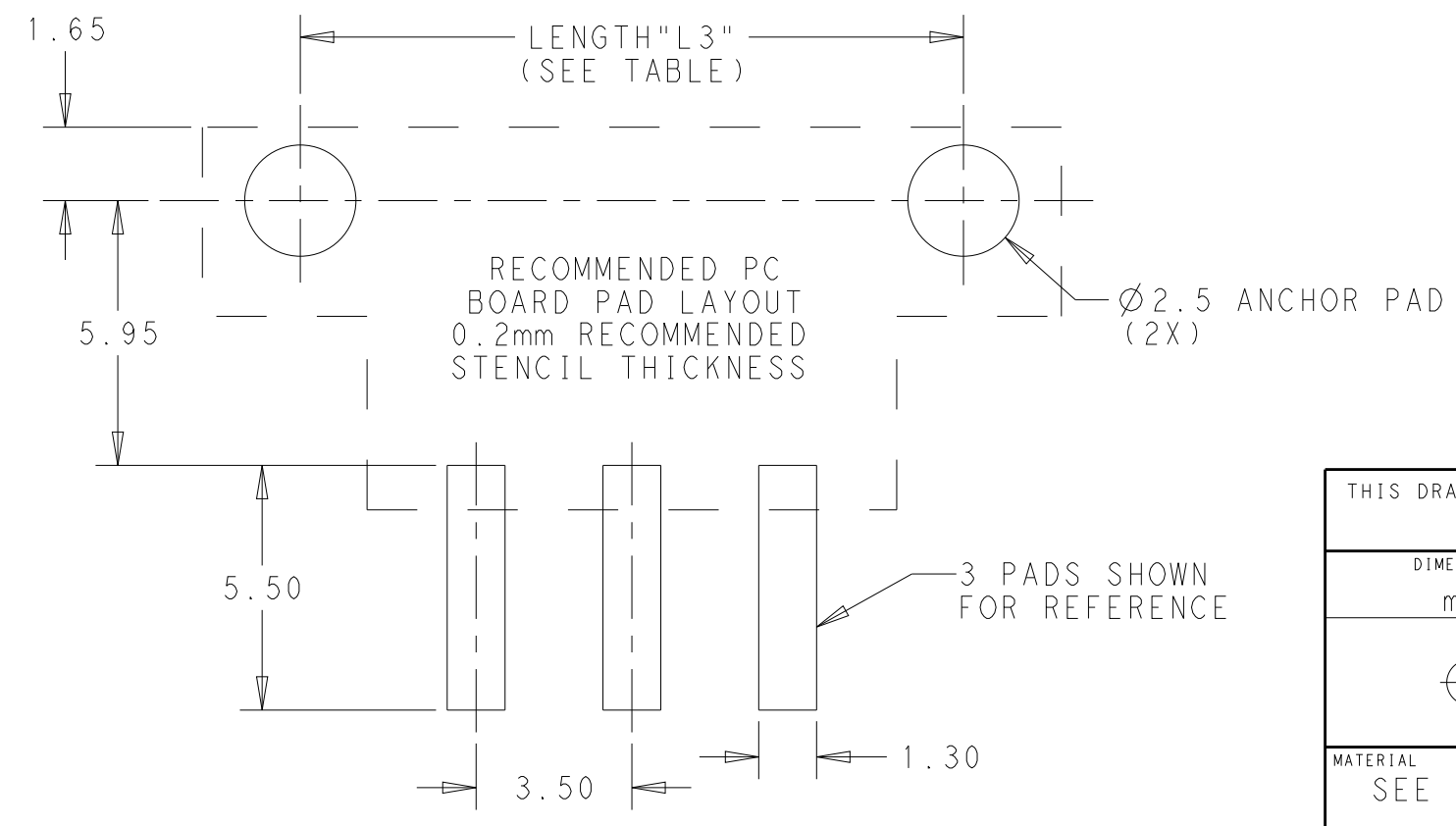
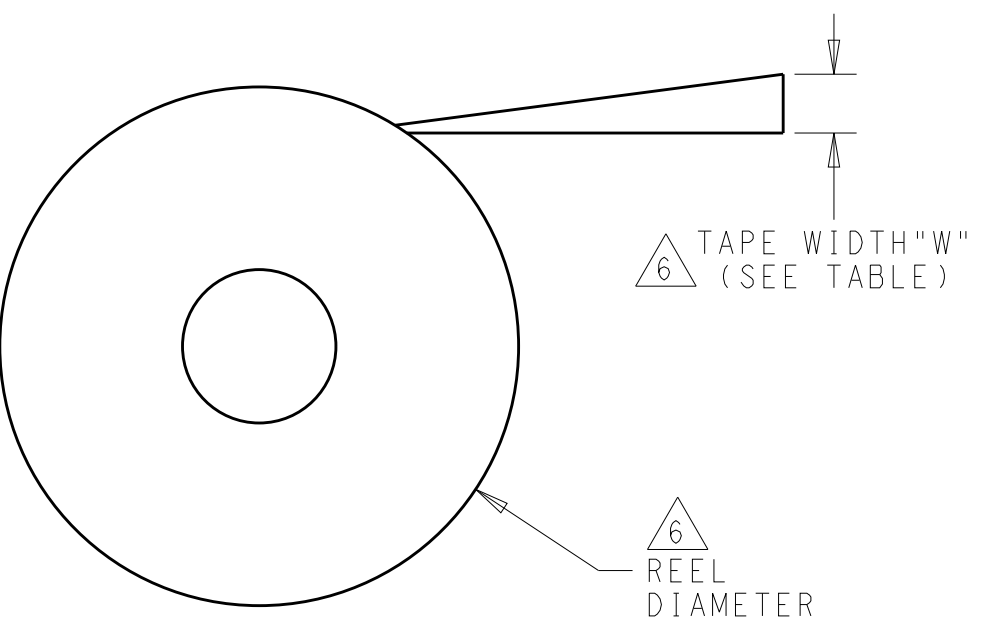
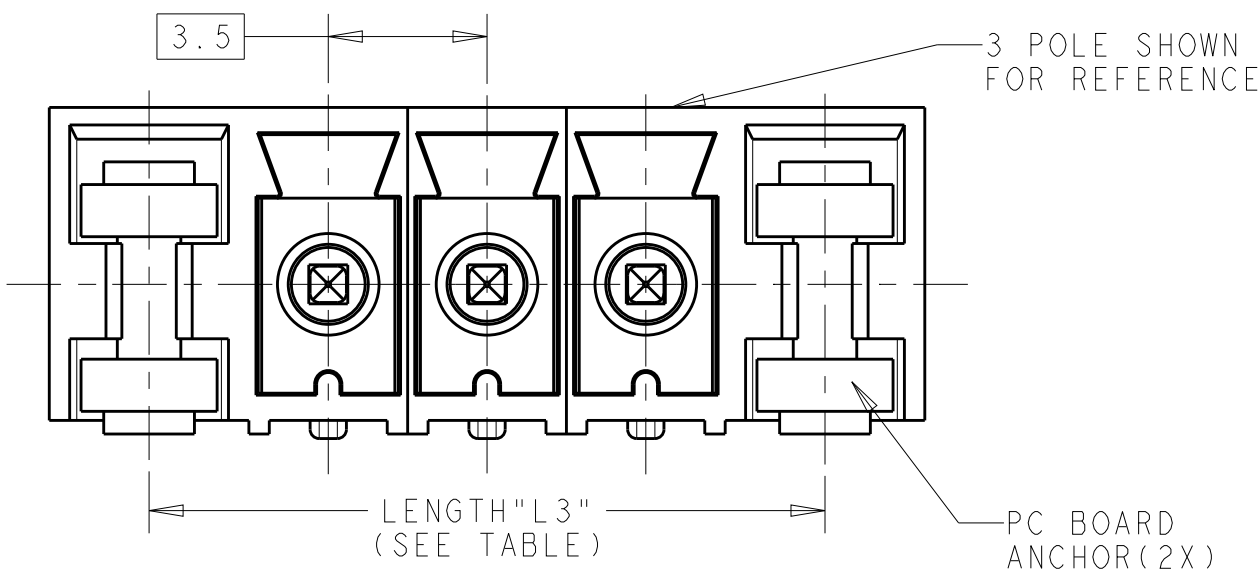
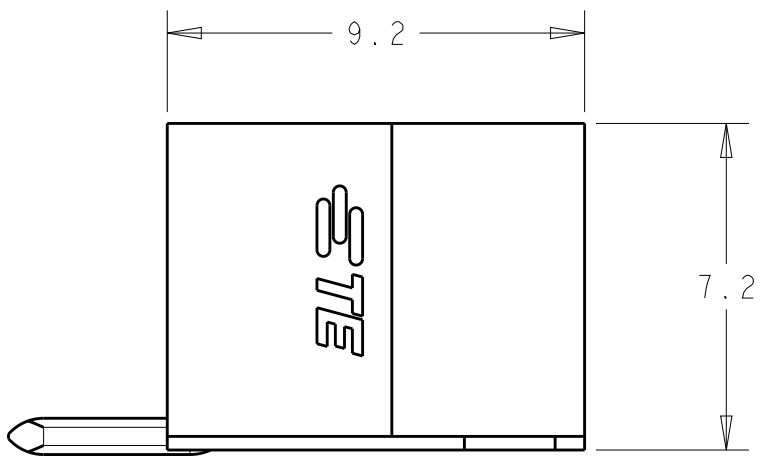
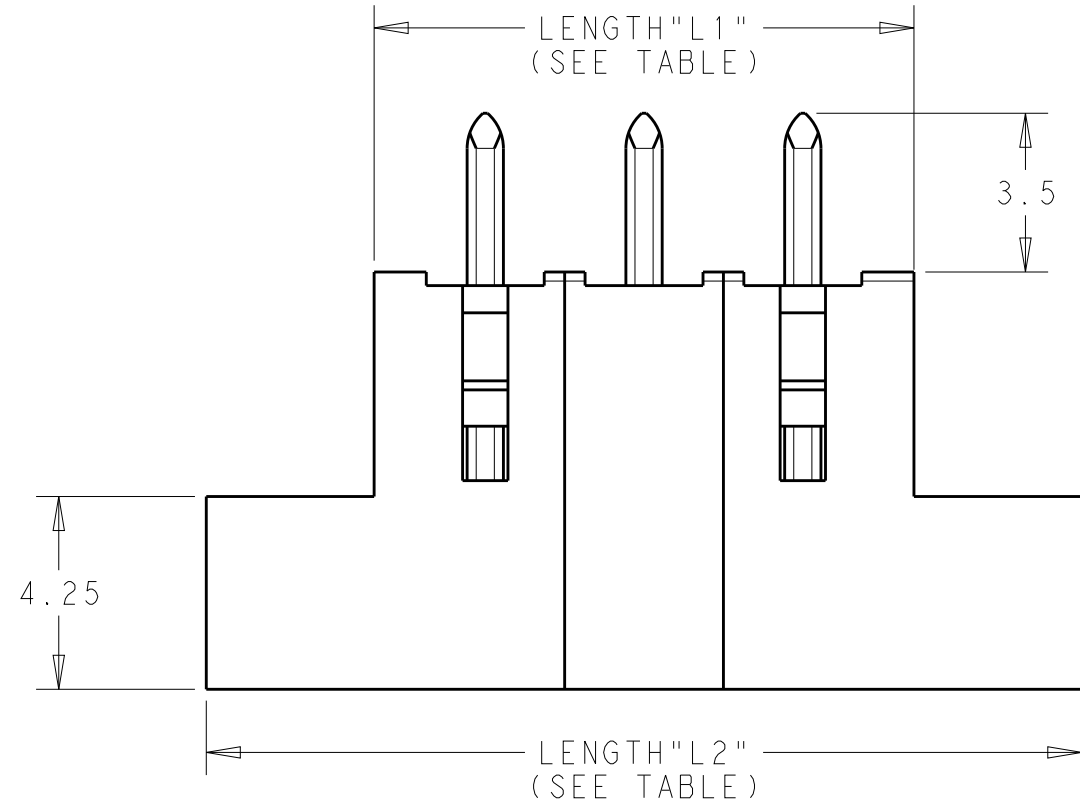
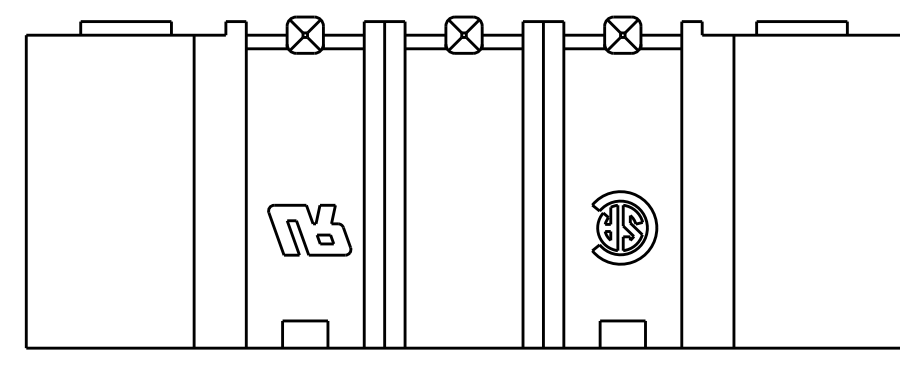
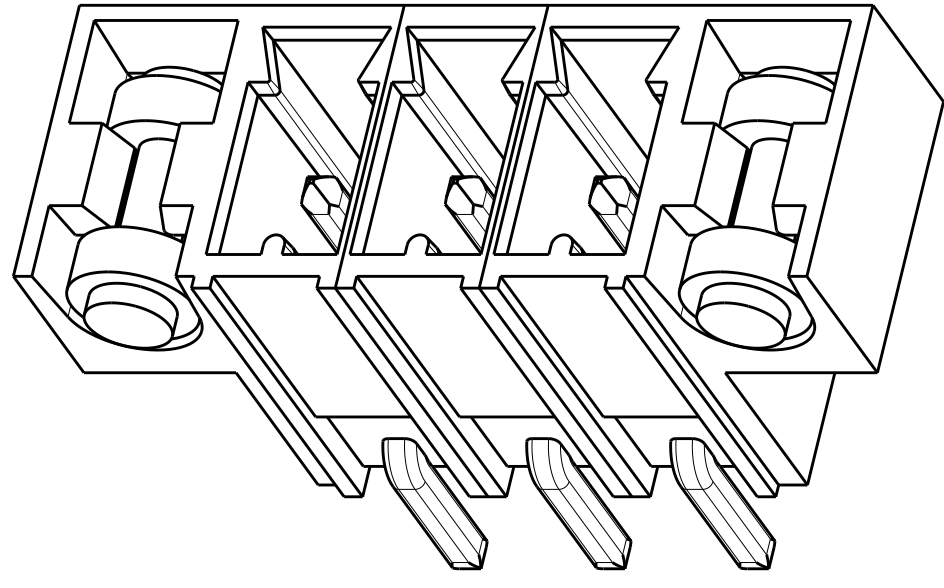

- HOUSING MATERIAL: THERMOPLASTIC, FLAME-RETARDANT PER UL94V-0 COLOR = BLACK
- CONTACT MATERIAL: COPPER ALLOY WITH TIN PLATE
- PRODUCT CERTIFICATIONS:
UL: 8A/300V (APPLICATION GROUPS B & D)
CSA: 8A/300V (APPLICATION GROUP B)
- MATING CONNECTOR: 2213936-SERIES
- HAZARDOUS SUBSTANCE COMPLIANCE: RoHS, REACH
- PACKAGING: TAPE AND REEL
REEL DIAMETER = 380mm
TAPE WIDTH = SEE TABLE

72	46.4	50.8	43.4	12	1-2213933-2
	42.9	47.3	39.9	11	1-2213933-1
	39.4	43.8	36.4	10	1-2213933-0
	35.9	40.3	32.9	9	2213933-9
56	32.4	36.8	29.4	8	2213933-8
	28.9	33.3	25.9	7	2213933-7
	25.4	29.8	22.4	6	2213933-6
	21.9	26.3	18.9	5	2213933-5
	18.4	22.8	15.4	4	2213933-4
	14.9	19.3	11.9	3	2213933-3
	11.4	15.8	8.4	2	2213933-2
	TAPE WIDTH "W" (mm)	LENGTH "L3" (mm)	LENGTH "L2" (mm)	LENGTH "L1" (mm)	NO. OF POLES

THIS DRAWING IS A CONTROLLED DOCUMENT.

DIMENSIONS: mm	TOLERANCES UNLESS OTHERWISE SPECIFIED:	DWN: RAVLS 14SEP2016	TE Connectivity
	0 PLC ±	CHK: M.LUKSIC 14SEP2016	
	1 PLC ±0.2	APVD: M.LUKSIC 14SEP2016	
MATERIAL: SEE NOTES	2 PLC ±0.13	PRODUCT SPEC: -	NAME: ANCHOR TERMINAL BLOCK HEADER, SMT, HORIZONTAL, 3.5MM PITCH
	3 PLC ±	APPLICATION SPEC: -	SIZE: A2
	4 PLC ±	WEIGHT: -	CAGE CODE: -
	ANGLES: ±	CUSTOMER DRAWING	DRAWING NO: C-2213933
	FINISH: ±	SCALE: 5:1	SHEET 1 OF 2
			REV: A1

THIS DRAWING IS UNPUBLISHED. RELEASED FOR PUBLICATION
 © COPYRIGHT copyright.dBTe- ALL RIGHTS RESERVED.

REVISIONS				
P	LTR	DESCRIPTION	DATE	APVD
-		SEE SHEET 1	-	-

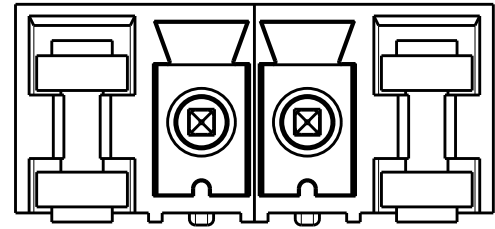

2 POLES: 2213933-2

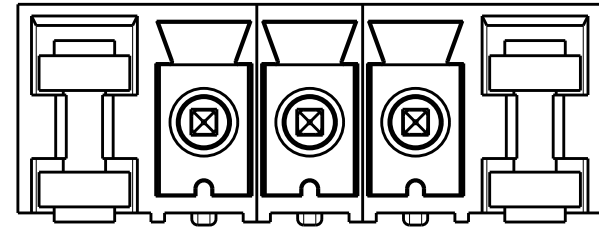

3 POLES: 2213933-3

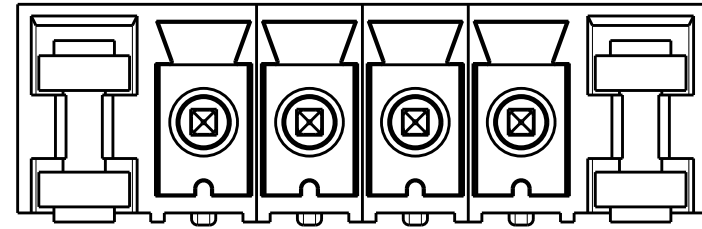

4 POLES: 2213933-4

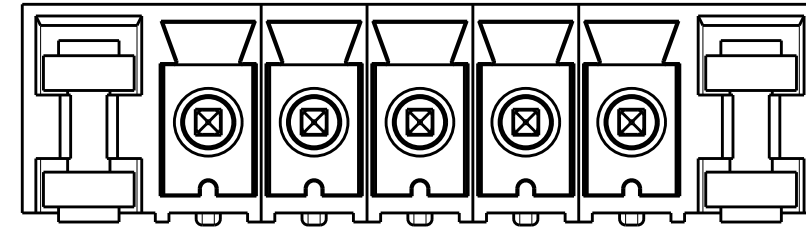

5 POLES: 2213933-5

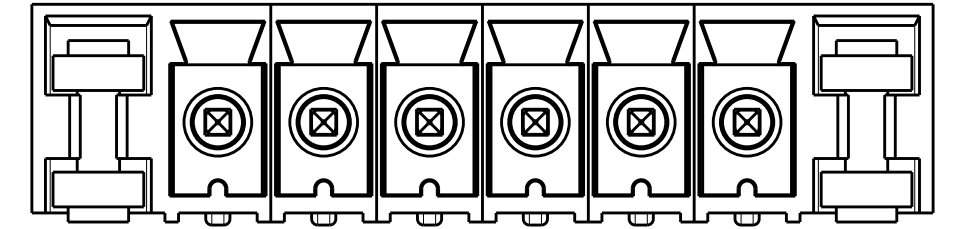

6 POLES: 2213933-6

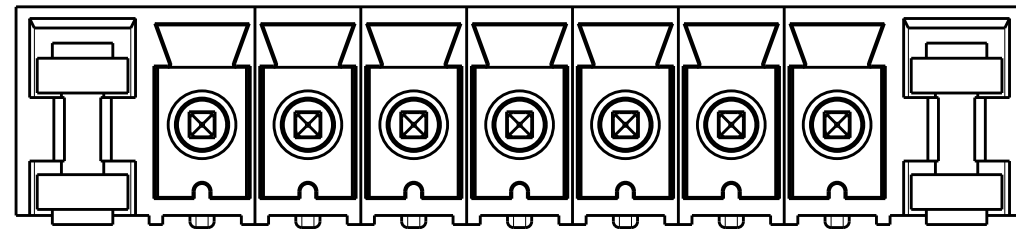

7 POLES: 2213933-7

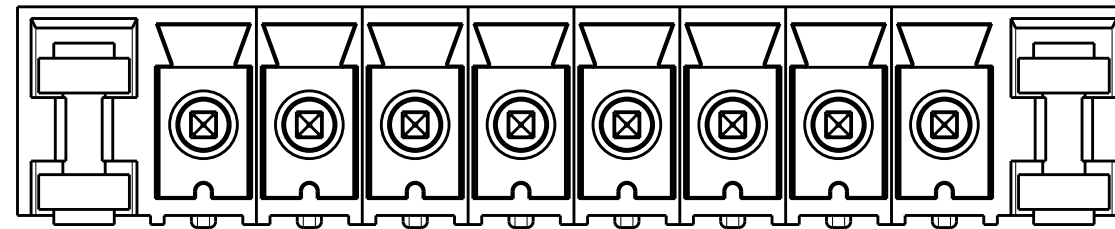

8 POLES: 2213933-8

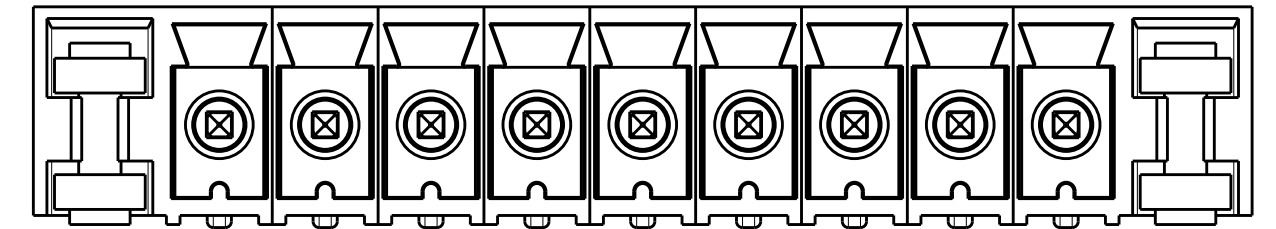

9 POLES: 2213933-9

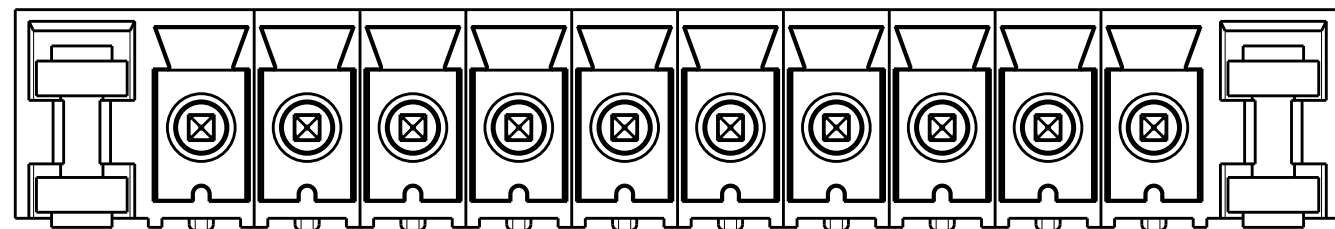

10 POLES: 1-2213933-0

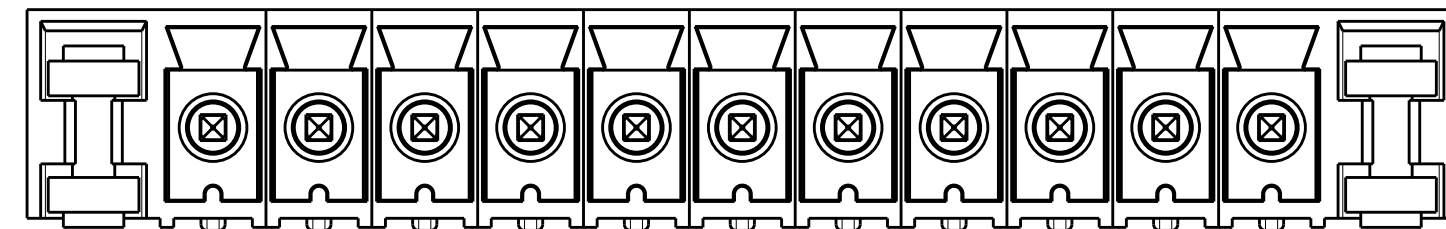

11 POLES: 1-2213933-1

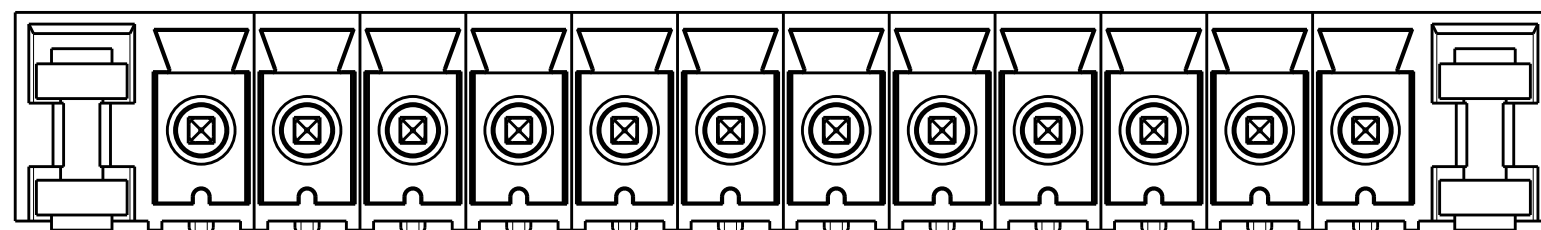

12 POLES: 1-2213933-2

THIS DRAWING IS A CONTROLLED DOCUMENT.		DWN RAVLS 14SEP2016	 TE Connectivity	
DIMENSIONS: mm		CHK M.LUKSIC 14SEP2016		
TOLERANCES UNLESS OTHERWISE SPECIFIED:		APVD M.LUKSIC 14SEP2016	NAME ANCHOR TERMINAL BLOCK HEADER, SMT, HORIZONTAL, 3.5MM PITCH	
0 PLC ± 1 PLC ±0.2 2 PLC ±0.13 3 PLC ± 4 PLC ± ANGLES ± FINISH		PRODUCT SPEC -	RESTRICTED TO -	
MATERIAL -		APPLICATION SPEC -	SIZE A2	CAGE CODE -
		WEIGHT -	DRAWING NO C-2213933	
		CUSTOMER DRAWING	SCALE 5:1	SHEET 2 OF 2
			REV A1	