

THIS IS A C.A.D. GENERATED DRAWING
DO NOT MAKE MANUAL REVISIONS TO MASTER.

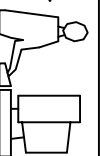

ISSUE NUMBER
ORIGINAL

①

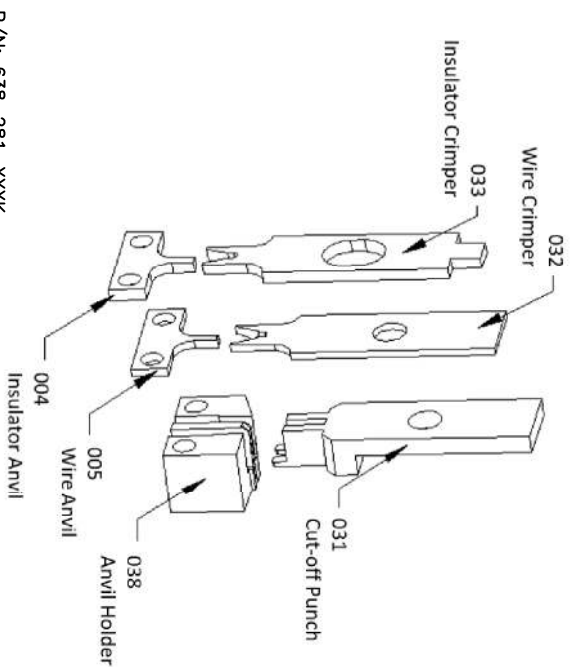
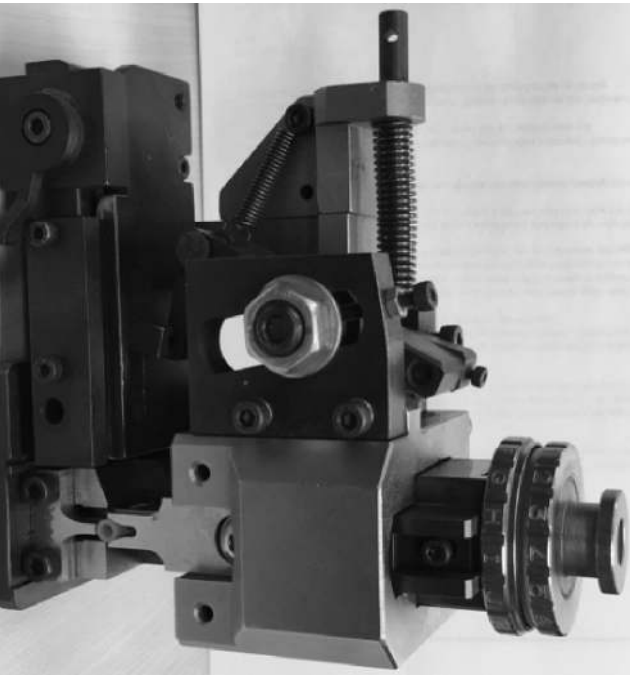

P/N: 638-281-XXXX

PRESS TYPE	K PRESS
STROKE LENGTH	30.00 MM
SHUT HEIGHT	119.55 MM
AWG	24-26

REPLACEMENT PUNCH & DIE PARTS					
INSULATOR ANVIL	WIRE ANVIL	WIRE CRIMPER	INSULATOR CRIMPER	CUT OFF PUNCH	ANVIL HOLDER
638-281-004K	638-281-005K	638-281-032K	638-281-033K	638-281-031K	638-281-038K

NOTES:

- 1- THIS APPLICATOR IS DESIGNED TO BE USED ON A K CRIMPING MACHINE.
- 2- THIS APPLICATOR IS DESIGNED FOR CRIMPING EDAC CONTACT P/N 638-292-271.
- 3- FOR THE DEFINITION OF STROKE LENGTH AND SHUT HEIGHT, APPLICATOR SETUP AND OPERATING INSTRUCTION, PLEASE REFER TO DOCUMENT "APPLICATOR INSTRUCTION MANUAL K PRESS".

K PRESS APPLICATOR FOR 638-292-271

EDAC INC
TORONTO, ONTARIO
CANADA

THESE DRAWINGS AND SPECIFICATIONS
ARE THE PROPERTY OF EDAC INC. AND
SHALL NOT BE REPRODUCED, OR COPIED
OR USED AS THE BASIS FOR THE
MANUFACTURE OR SALE OF APPARATUS
WITHOUT WRITTEN PERMISSION.

ACAD REFERENCE NO.	638-280-751K	
DRAWN:	K.L.	DATE: OCT.30/2020
CHECKED:	R.S.M.	DATE: OCT.30/2020
SCALE:	N.T.S.	SHEET 1 OF 1
DRAWING NUMBER	638-280-751K	
ISSUE	1	