

350036

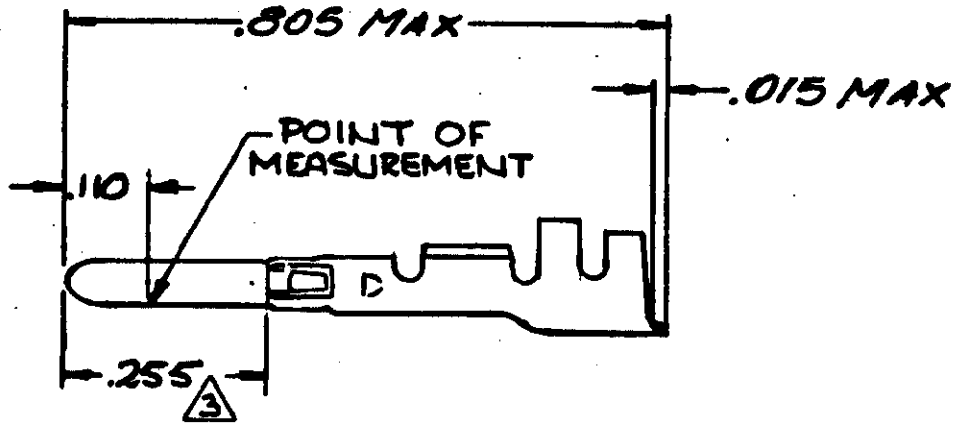

1. FOR ADDITIONAL INFORMATION SEE DWG 350018.
  2. THIS TERMINAL TO BE SUPPLIED IN INDIVIDUAL FORM, NOT AS CONTINUOUS STRIP.
- △ PLATED WITH .000030 GOLD, OVER .000050 NICKEL UNDERPLATE.

PART NO.	MATERIAL & FINISH
350036-1	.008 BRASS - PRE-TIN
350036-2	.008 BRASS - GOLD △

DIMENSIONS IN INCHES. DO NOT SCALE PRINT.

G	REVISED PER ECR-22-161356	15DEC22	M.J	T.S
F	REVISED PER ECR-22-159524	25NOV22	M.J	T.S

Unpublished copy not to be reproduced nor published without written permission of AMP Incorporated

E1	RESTORED		BO/RS	10/1/83
E	REVISED PER M-7349	TW	JH	5/1/83
D	ADDED NOTE 3, m-6086	MF	JH	11/13/80
C	REVISED M-4049		MF/JH	1-10-77
B	FEED LATCH	M-1500	MF/JH	2/12/76
A	REVISED DESIGN	M-1661	MF/RS	1/13
LTR	REVISION RECORD	ECN	OP	CHK

©1977 BY AMP INCORPORATED. ALL RIGHTS RESERVED. AMP PRODUCTS COVERED BY PATENTS AND/OR PATENTS PENDING

CUSTOMER COPY REFERENCE ONLY

MATERIAL AND FINISH  
**SEE TABLE**



AMP INCORPORATED  
HARRISBURG, PENNSA

CLASS —#—

WIRE — RANGE — INSULATION  
#26-#18 .050-.115

TYPE —#—

TOLERANCE EXCEPT AS NOTED ± 0.15 ± 1.0

LOC. CM A NO. 350036 REL. G

DR. **JIM KUNKLE** 6-7-71  
CHK APP 6-7-71

NAME .058 DIA PIN (LOOSE PIECE)