

THIS DRAWING IS UNPUBLISHED. RELEASED FOR PUBLICATION  
 © COPYRIGHT BY TYCO ELECTRONICS CORPORATION. ALL RIGHTS RESERVED.

LOC	DIST	REVISIONS			
P	LTR	DESCRIPTION	DATE	DWN	APVD
AJ	16	AK	REVISED PER ECO-10-008433	21MAY10	HMR KW

- 1. COPPER ALLOY
- 2. 5.08  $\mu\text{m}$  [.000200] MINIMUM THICK SILVER PLATE PER QQ-S-365
- 3. 2.54  $\mu\text{m}$  [.000100] MINIMUM THICK TIN-LEAD PLATE PER ASTM-B-545, WITH SUPPLEMENTAL ANTI FRETTING LUBRICANT.
- 4. 2.54  $\mu\text{m}$  [.000100] MINIMUM THICK MATTE TIN PLATE, WITH SUPPLEMENTAL ANTI FRETTING LUBRICANT.

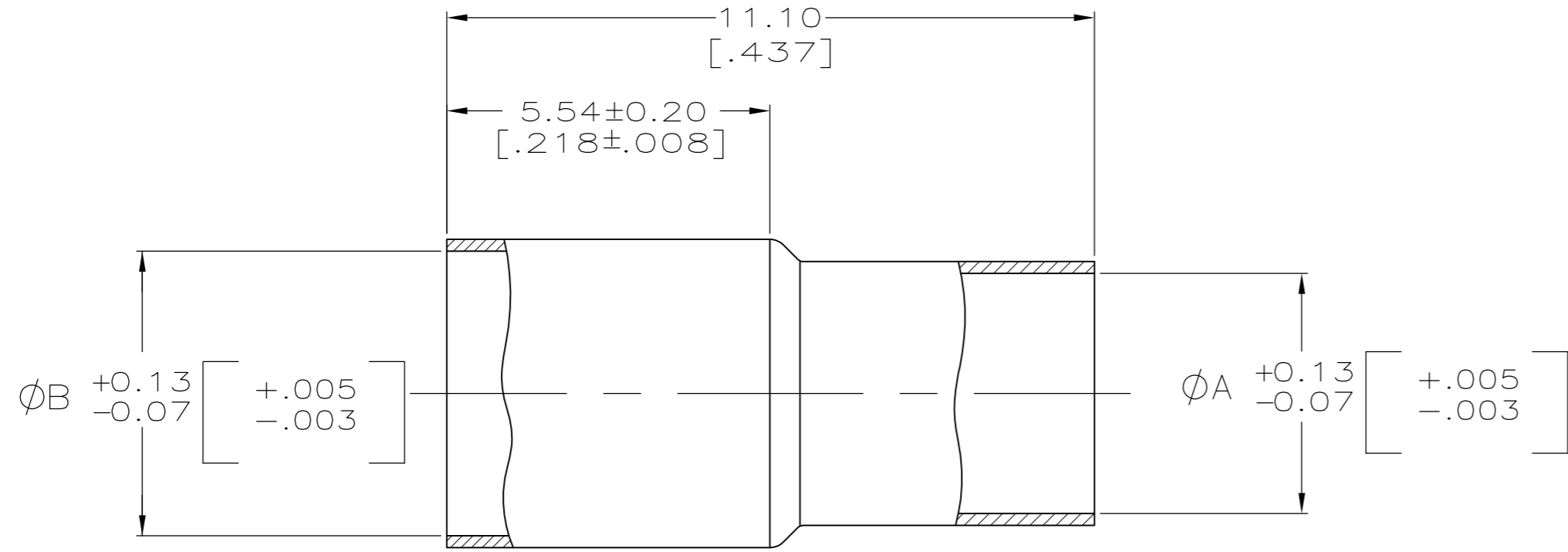

VIEW C

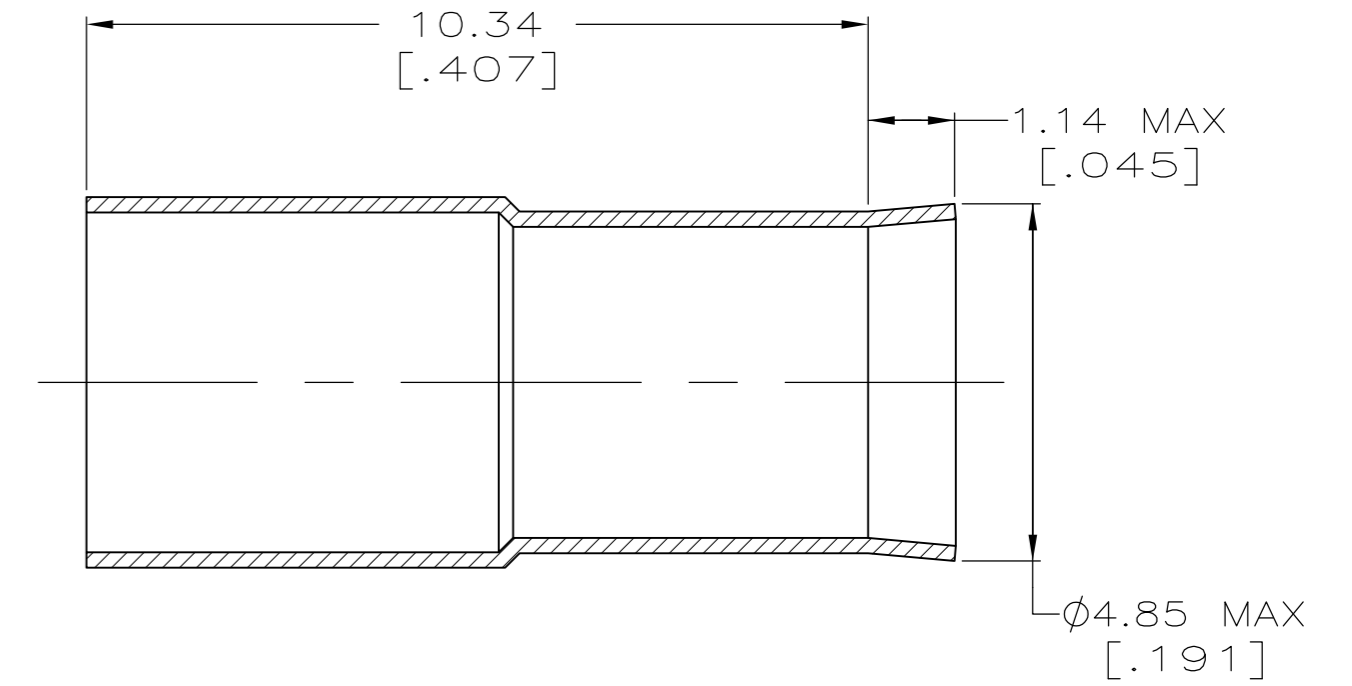

VIEW Z  
SAME AS VIEW C EXCEPT AS SHOWN

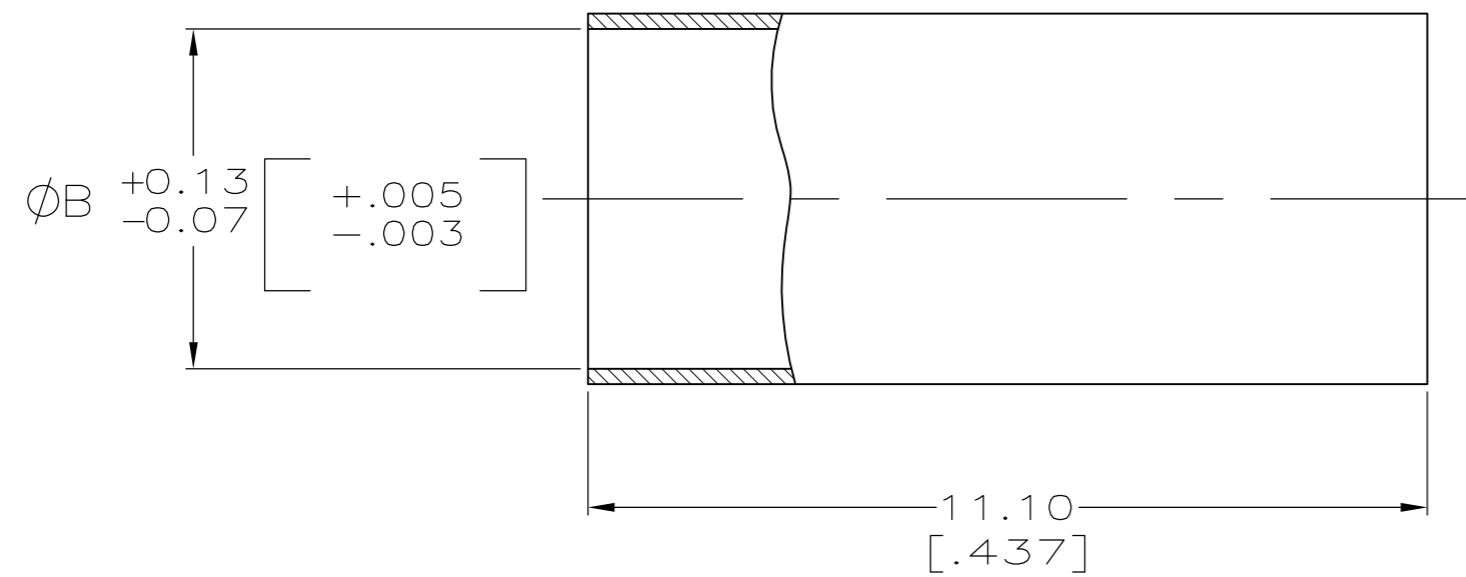

VIEW D

	VIEW	B	A	FINISH	PART NUMBER
SUPERCEDED BY 9-329461-0	D	4.50 [.177]	-	4	9-329461-2
	Z	4.50 [.177]	4.11 [.162]	4	9-329461-1
OBSOLETE	Z	4.50 [.177]	4.11 [.162]	4	9-329461-0
	D	4.50 [.177]	-	3	3-329461-3
OBSOLETE	C	4.88 [.192]	4.22 [.166]	3	2-329461-9
	Z	4.50 [.177]	4.11 [.162]	4	2-329461-7
OBSOLETE	C	4.88 [.192]	4.22 [.166]	2	2-329461-6
OBSOLETE	D	4.50 [.177]	-	2	2-329461-2
	Z	4.50 [.177]	4.11 [.162]	2	329461

THIS DRAWING IS A CONTROLLED DOCUMENT.		DWN	J. L. GROFT	9-24-90	Tyco Electronics Corporation Harrisburg, PA, 17105-3608
DIMENSIONS: MM [INCHES]		CHK	M. SNEED	1-30-91	
TOLERANCES UNLESS OTHERWISE SPECIFIED:		APVD	R. HENRY	1-30-91	
0 PLC ± - 1 PLC ± - 2 PLC ± 0.38 [.015] 3 PLC ± - 4 PLC ± - ANGLES ± -		PRODUCT SPEC	-		
MATERIAL SEE NOTES		FINISH	SEE NOTES		NAME
		WEIGHT	-		SIZE
		CUSTOMER DRAWING	SCALE 10:1		CAGE CODE
			SHEET 1 OF 1		DRAWING NO
			REV AK		RESTRICTED TO

329461

A