

© 2021 TE Connectivity. All Rights Reserved.	
PROJECT	PRJ-14-000004825
PART NO	X-2823450-X
HV DESC	M12, A-CODED,RAIL FEMALE CRIMP
CUSTOMER	GENERAL MARKET

REVISIONS				
P	LTR	DESCRIPTION	DATE	APVD
	A5	CRIMP TOOL INFORMATION UPDATED	18JAN2021	GK SE

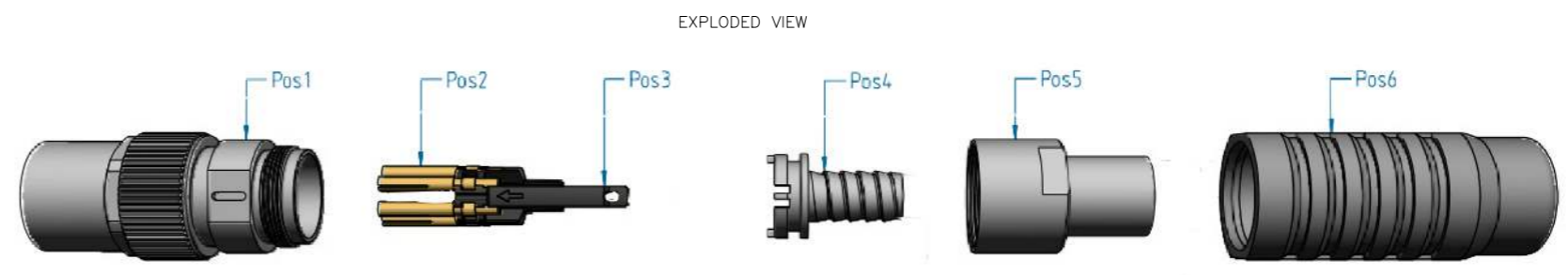
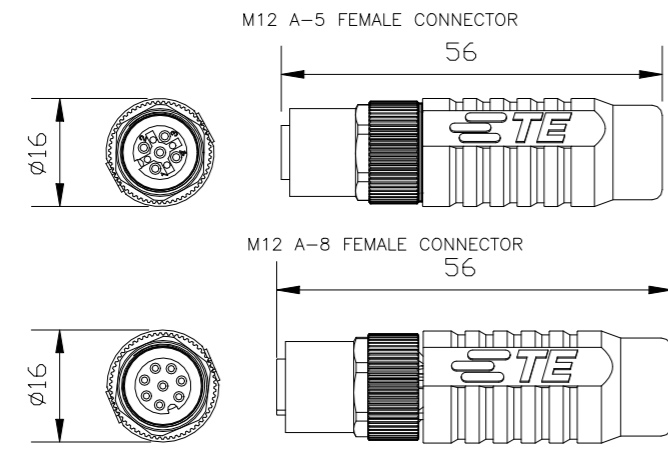

TE PN	Description	Coding	Number of positions	Gender	Number of contacts included	Connector type	Applicable on cable	Manufacturer PN	Category	Color	Conductor size	Cable preparation		Recommended Contact crimping tools		Recommended Jacket Crimping Tools		Crimp Flange insertion		Connector assembly tool			
												Conductor stripping	Jacket cutting	Hand tool	Contact positioner	Crimp Selection number*	Crimp Tool	Tool Setting	Handle		Insert for handle		
1-2823450-1	M12 A-F-5, CAT 5 RADOX 6.6MM, H&S	A	5	Female	5	Straight	Radox 6.6mm	H&S 12584038	Cat 5	Black	4 x AWG22	734185-1	2119000-1	601966-1	1-2823581-1	6	2380757-2	ORANGE	1-2823560-1	1-2823561-1	1-2823564-1		
1-2823450-2	M12 A-F-5, CAT 5 RADOX 7.3MM, H&S		5		Radox 7.3mm		H&S 12568935	Cat 5	Black	4 x AWG22	1-2823581-1											6	GREEN
1-2823450-3	M12 A-F-5, CAT 5 RADOX 8.3MM, H&S		5		Radox 8.3mm		H&S 12585489	Cat 5	Black	4 x AWG20	1-2823581-1											7	BLUE
1-2823450-4	M12 A-F-8, CAT 5 RADOX 7.3MM, H&S		8		Radox 7.3mm		H&S 12568935	Cat 5	Black	4 x AWG22	1-2823582-9											5	GREEN
1-2823450-5	M12 A-F-8, CAT 5 RADOX 6.6MM, H&S		8		Radox 6.6mm		H&S 12584038	Cat 5	Black	4 x AWG22	1-2823582-9											5	ORANGE
1-2823450-6	M12 A-F-8, CAT 7, 8.4MM, TE		8		TE Cat 7 cable TECC0011C7		TE 2297799-1	Cat 7	Blue	8 x AWG24	1-2823582-9											5	YELLOW
1-2823450-7	M12 A-F-5, CAT 7, 8.4MM, TE		5		TE Cat 7 cable TECC0011C7		TE 2297799-1	Cat 7	Blue	8 x AWG24	1-2823581-1											5	YELLOW
1-2823450-8	M12 A-F-5, CAT 5E, 6.5 MM, TE		5		TE Cat 5e cable TECC0026CS		TE 2320808-1	Cat 5e	Blue	4 x AWG22	1-2823581-1											6	ORANGE

\*TOOL SETTING MUST BE VALIDATED ON CABLE USED



ISO VIEW  
M12 A-5 FEMALE CONNECTOR

ISO VIEW  
M12 A-8 FEMALE CONNECTOR

- NOTES:
- ALL DIMENSIONS ARE FOR NOMINAL REFERENCE ONLY.
  - PACKAGING: 1 PIECE IN A BOX, CONTACTS INCLUDED.
  - THE CONNECTOR IS AS PER IEC 61076-2-101
  - TEMPERATURE RANGE: WITH CABLE BOOT -40°C TO +70°C. WITHOUT CABLE BOOT -40°C TO +85°C.
  - VIBRATION & SHOCK TEST CONDUCTED AS PER IEC 61373:CAT 1 CLASS B.
  - FIRE PERFORMANCE CONDUCTED AS PER EN45545-2 HL3 R22/R23 NFF16-101 AND NFF16-102.
  - SPECIAL CRIMP FLANGE SYSTEM WITH CRIMP INSERT AND CRIMP SLEEVE SECURES THE EFFECTIVE SHIELDING OVER THE LIFETIME WITH EXTREMELY HARD CONDITIONS.
  - VIBRATION AND TORSION-PROOF CABLE STRAIN RELIEF FOR ROUGH ENVIRONMENT ACHIEVED BY HEXAGONAL CRIMP OF THE CRIMP SLEEVE OF THE CRIMP FLANGE SYSTEM.
  - DEGREE OF PROTECTION: IP 67 (ONLY SCREW-LOCKED).
  - DATA TRANSMISSION RATE: UP TO 10Gbit/s
  - CURRENT RATING: A8: 2A NOMINAL VOLTAGE: 30V, CONTACT RESISTANCE: ≤ 5 mΩ, INSULATION RESISTANCE: ≥ 100 mΩ.
  - CURRENT RATING: A5: 4A, NOMINAL VOLTAGE: 250V AC/ 50V DC, CONTACT RESISTANCE: ≤ 5 mΩ, INSULATION RESISTANCE: ≥ 100 mΩ.
  - DURABILITY: ≥ 200 MATING CYCLES

SL. NO.	DESCRIPTION	MATERIAL	QTY	UNITS
6	GRIP BOOT	TPE WITH S3 & SR2 (DIN 5510-2)	1	PC
5	BACK NUT & SLEEVE	Cu ALLOY Ni-PLATED	1	PC
4	CRIMP INSERT	Cu ALLOY Ni-PLATED	1	PC
3	CONTACT HOLDER	THERMOPLAST	1	PC
2	CRIMP CONTACTS MACHINED	Cu ALLOY Ni-Au PLATED	SEE TABLE	PC
1	FRONT HOUSING	Cu ALLOY Ni-PLATED	1	PC

THIS DRAWING IS A CONTROLLED DOCUMENT.		DWN 16APR2019 GOPALAKRISHNA HV	TE Connectivity <b>M12, A-CODED RAIL FEMALE, CRIMP CONNECTORS</b>												
DIMENSIONS: mm		CHK 16APR2019 S EGBERT			NAME										
TOLERANCES UNLESS OTHERWISE SPECIFIED:		APVD 16APR2019 S EGBERT			PRODUCT SPEC										
<table border="1"> <tr><td>0 PLC</td><td>± -</td></tr> <tr><td>1 PLC</td><td>± -</td></tr> <tr><td>2 PLC</td><td>± -</td></tr> <tr><td>3 PLC</td><td>± -</td></tr> <tr><td>4 PLC</td><td>± -</td></tr> <tr><td>ANGLES</td><td>± -</td></tr> </table>		0 PLC			± -	1 PLC	± -	2 PLC	± -	3 PLC	± -	4 PLC	± -	ANGLES	± -
0 PLC	± -														
1 PLC	± -														
2 PLC	± -														
3 PLC	± -														
4 PLC	± -														
ANGLES	± -														
MATERIAL	FINISH	WEIGHT	SIZE	CAGE CODE	DRAWING NO	RESTRICTED TO									
-	-	-	A3	00779	C-2823450	-									
CUSTOMER DRAWING			SCALE	SHEET	REV										
			NTS	1 OF 1	A5										