

BGSF18DM20

SP8T Antenna Switch Module with integrated SPI controller, 2 GSM-Tx and 6 WCDMA-TRx Ports for 2G/3G Convergence

Data Sheet

Revision 2.4, 2013-05-31

Edition 2011-03-07

**Published by
Infineon Technologies AG
81726 Munich, Germany**

**© 2011 Infineon Technologies AG
All Rights Reserved.**

Legal Disclaimer

The information given in this document shall in no event be regarded as a guarantee of conditions or characteristics. With respect to any examples or hints given herein, any typical values stated herein and/or any information regarding the application of the device, Infineon Technologies hereby disclaims any and all warranties and liabilities of any kind, including without limitation, warranties of non-infringement of intellectual property rights of any third party.

Information

For further information on technology, delivery terms and conditions and prices, please contact the nearest Infineon Technologies Office (www.infineon.com).

Warnings

Due to technical requirements, components may contain dangerous substances. For information on the types in question, please contact the nearest Infineon Technologies Office.

Infineon Technologies components may be used in life-support devices or systems only with the express written approval of Infineon Technologies, if a failure of such components can reasonably be expected to cause the failure of that life-support device or system or to affect the safety or effectiveness of that device or system. Life support devices or systems are intended to be implanted in the human body or to support and/or maintain and sustain and/or protect human life. If they fail, it is reasonable to assume that the health of the user or other persons may be endangered.

BGSF18DM20 SP8T Antenna Switch Module with integrated SPI controller, 2 GSM-Tx and 6 WCDMA-TRx Ports for 2G/3G Convergence

Confidential

Revision History: 2013-05-31, Revision 2.4

Previous Revision: 2012-03-28, Revision 2.3

Page	Subjects (major changes since last revision)
	no changes - make it public version

Trademarks of Infineon Technologies AG

A-GOLD™, BlueMoon™, COMNEON™, CONVERGATE™, COSIC™, C166™, CROSSAVE™, CanPAK™, CIPOST™, CoolMOS™, CoolSET™, CONVERPATH™, CORECONTROL™, DAVE™, DUALFALC™, DUSLIC™, EasyPIM™, EconoBRIDGE™, EconoDUAL™, EconoPACK™, EconoPIM™, E-GOLD™, EiceDRIVER™, EUPEC™, ELIC™, EPIC™, FALC™, FCOS™, FLEXISLIC™, GEMINAX™, GOLDMOS™, HITFET™, HybridPACK™, INCA™, ISACT™, ISOFACE™, IsoPACK™, IWORX™, M-GOLD™, MIPAQ™, ModSTACK™, MUSLIC™, my-d™, NovalithIC™, OCTALFALC™, OCTAT™, OmniTune™, OmniVia™, OptiMOS™, OPTIVERSE™, ORIGAT™, PROFET™, PRO-SIL™, PrimePACK™, QUADFALC™, RASIC™, ReverSave™, SatRIC™, SCEPTRE™, SCOUT™, S-GOLD™, SensoNor™, SEROCCO™, SICOFI™, SIEGET™, SINDRION™, SLIC™, SMARTi™, SmartLEWIS™, SMINT™, SOCRATES™, TEMPFET™, thinQ!™, TrueENTRY™, TriCore™, TRENCHSTOP™, VINAX™, VINETIC™, VIONTIC™, WildPass™, X-GOLD™, XMM™, X-PMU™, XPOSYS™, XWAY™.

Other Trademarks

AMBA™, ARM™, MULTI-ICE™, PRIMECELL™, REALVIEW™, THUMB™ of ARM Limited, UK. AUTOSAR™ is licensed by AUTOSAR development partnership. Bluetooth™ of Bluetooth SIG Inc. CAT-iq™ of DECT Forum. COLOSSUS™, FirstGPS™ of Trimble Navigation Ltd. EMV™ of EMVCo, LLC (Visa Holdings Inc.). EPCOS™ of Epcos AG. FLEXGO™ of Microsoft Corporation. FlexRay™ is licensed by FlexRay Consortium. HYPERTERMINAL™ of Hilgraeve Incorporated. IEC™ of Commission Electrotechnique Internationale. IrDA™ of Infrared Data Association Corporation. ISO™ of INTERNATIONAL ORGANIZATION FOR STANDARDIZATION. MATLAB™ of MathWorks, Inc. MAXIM™ of Maxim Integrated Products, Inc. MICROTEC™, NUCLEUS™ of Mentor Graphics Corporation. Mifare™ of NXP. MIPI™ of MIPI Alliance, Inc. MIPS™ of MIPS Technologies, Inc., USA. muRata™ of MURATA MANUFACTURING CO. OmniVision™ of OmniVision Technologies, Inc. Openwave™ Openwave Systems Inc. RED HAT™ Red Hat, Inc. RFMD™ RF Micro Devices, Inc. SIRIUS™ of Sirius Sattelite Radio Inc. SOLARIS™ of Sun Microsystems, Inc. SPANSION™ of Spansion LLC Ltd. Symbian™ of Symbian Software Limited. TAIYO YUDEN™ of Taiyo Yuden Co. TEAKLITE™ of CEVA, Inc. TEKTRONIX™ of Tektronix Inc. TOKO™ of TOKO KABUSHIKI KAISHA TA. UNIX™ of X/Open Company Limited. VERILOG™, PALLADIUM™ of Cadence Design Systems, Inc. VLYNQ™ of Texas Instruments Incorporated. VXWORKS™, WIND RIVER™ of WIND RIVER SYSTEMS, INC. ZETEX™ of Diodes Zetex Limited.

Last Trademarks Update 2009-10-19

Table of Contents

	Table of Contents	4
	List of Figures	5
	List of Tables	6
1	Features	7
2	Maximum Ratings	9
3	Operation Ranges	10
4	Electrical Characteristics	11
5	Pin Definition and Package Outline	13
6	SPI Command Set	16

List of Figures

Figure 1	ASM Configuration with Lext = 1.5nH (optional)	8
Figure 2	Pin Configuration	14
Figure 3	Package Outline	14
Figure 4	Marking	15
Figure 5	SPI Command Set	16



List of Tables

Table 1	Maximum Ratings	9
Table 2	Operation Ranges	10
Table 3	RF Characteristics	11
Table 4	Pin Configuration	13
Table 5	Mechanical Data	13

1 Features

Main Features

- 2 high-linearity GSM Tx paths with power handling capability of up to 36 dBm
- 6 high-linearity WCDMA TRx ports
- Integrated harmonic filters for GSM High and Low bands
- Integrated ESD protection at ANT port
- Low insertion loss
- Low harmonic generation
- On chip control logic including ESD protection
- Suitable for Quadband GSM / Edge / C2K / LTE / WCDMA Applications
- 0.1 to 2.7 GHz coverage
- High port-to-port-isolation
- No external DC blocking capacitors required
- Integrated SPI decoder supporting logic levels from 1.35 V to 3.3 V
- Direct connect to battery
- Small form factor 3.2 mm x 2.8 mm
- Height 1.0 mm max.

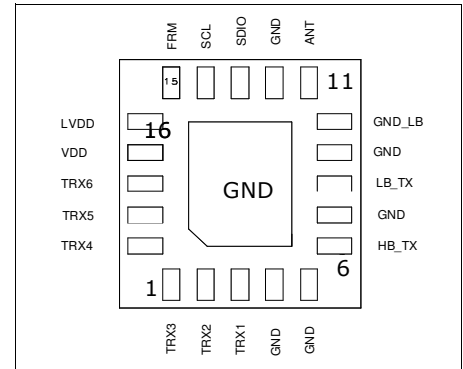

Description

The BGSF18DM20 is a Single Pole Eight Throw (SP8T) switch module optimized for wireless applications up to 2.7 GHz. It is a perfect solution for multimode handsets based on GSM Quadband and WCDMA. The switch module configuration is shown in [Figure 1](#). The module comes in a miniature LGA Package and comprises of a high power CMOS SP8T switch with integrated SPI controller and harmonic filters for GSM high and low band transmit paths. The on-chip controller integrates CMOS logic and level shifters, driven by control inputs from 1.35 to 3.3 V. The module features direct-connect-to-battery functionality and DC-free RF ports.

The antenna port has integrated ESD protection to achieve 8kV ESD robustness without external components.

Product Name	Package	Chip	Marking
BGSF18DM20	PG-VCCN-20-1	M4783A	1XX / YWW / 1.3

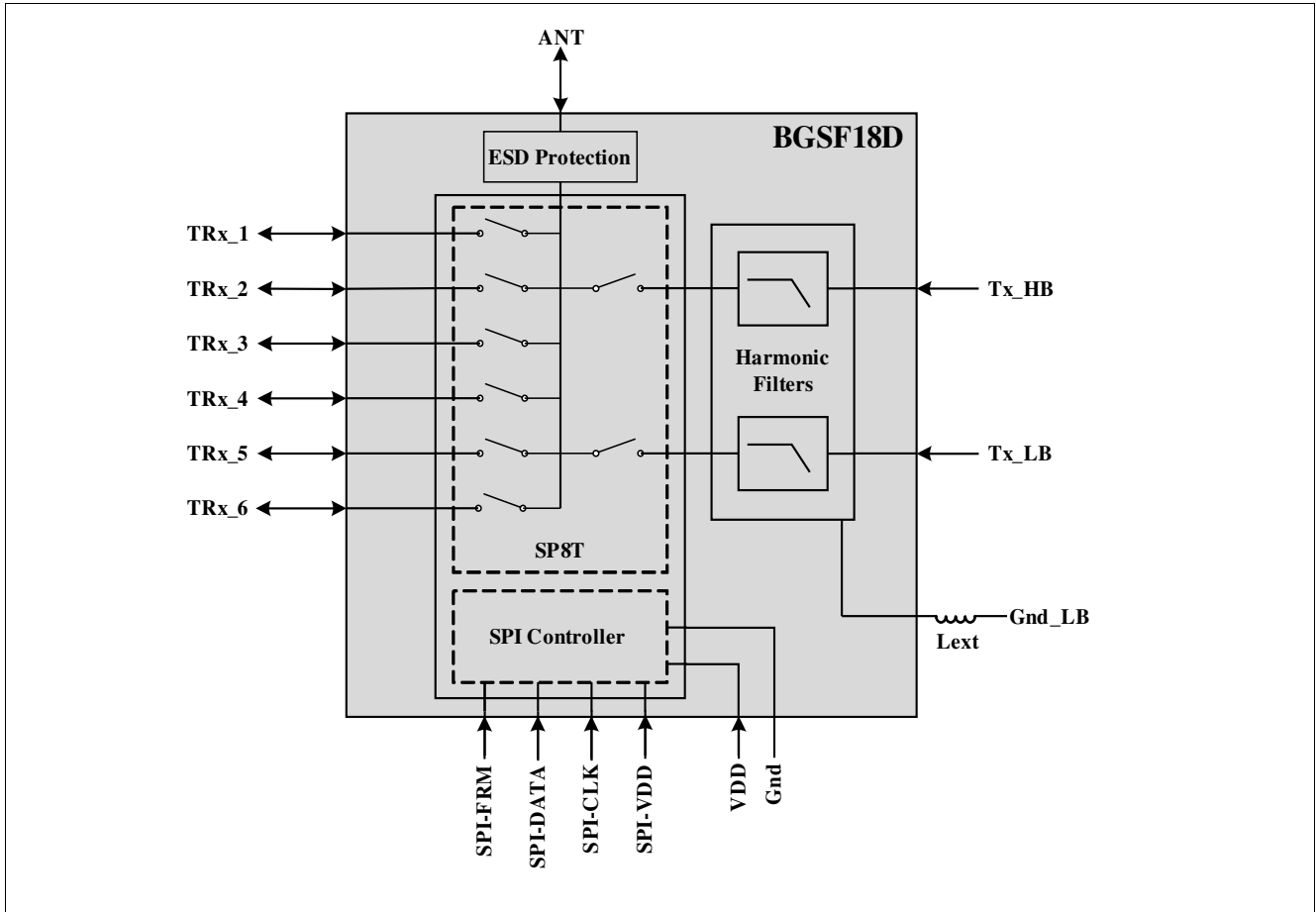

Figure 1 ASM Configuration

2 Maximum Ratings

Table 1 Maximum Ratings

Parameter	Symbol	Values			Unit	Note / Test Condition
		Min.	Typ.	Max.		
Supply Voltage	V_{dd}	-0.5	–	5.5	V	–
Storage temperature range	T_{STG}	-55	–	+150	°C	–
RF input power at all GSM Tx ports	P_{inTx}	–	–	+36	dBm	–
RF input power at all TRx ports	P_{inTRx}	–	–	+32	dBm	–
ESD capability Human Body Model	V_{ESD_HBM}	1000	–	–	V	–
ESD capability ANT port (according IEC 61000-4-2 contact)	V_{ESD_ANT}	8000	–	–	V	–
Junction temperature	T_j	–	–	+125	°C	–
Thermal resistance junction - soldering point	R_{thJS}	–	–	80	K/W	–

Attention: Stresses above the max. values listed here may cause permanent damage to the device. Exposure to absolute maximum rating conditions for extended periods may affect device reliability. Maximum ratings are absolute ratings; exceeding only one of these values may cause irreversible damage to the integrated circuit.

3 Operation Ranges

Table 2 Operation Ranges

Parameter	Symbol	Values			Unit	Note / Test Condition
		Min.	Typ.	Max.		
Supply Voltage	V_{dd}	2.85	3.5	4.7	V	–
Supply current	I_{dd}	100	250	400	μ A	–
SPI supply voltage	V_{dd_SPI}	1.6	1.8	3.5	V	–
SPI Control voltage low	V_{Ctrl_L}	-0.3	0	0.3	V	–
SPI Control voltage high	V_{Ctrl_H}	1.35	V_{dd}	$V_{dd_SPI} + 0.3$ V	V	–
SPI Control current	I_{Ctrl}	5	250	400	μ A	–
RF frequency	f_{RF}	0.1	0.8 - 2.1	2.7	GHz	–
Ambient temperature range	T_A	-30	+25	+85	$^{\circ}$ C	–
Input Power						
TRx ports (VSWR = 4:1)	P_{in_TRx}	–	–	25	dBm	–
GSM Tx port @ 1 GHz (VSWR = 4:1)	P_{inGSM_F1}	–	–	35	dBm	–
GSM Tx port @ 2 GHz (VSWR = 4:1)	P_{inGSM_F2}	–	–	33	dBm	–

4 Electrical Characteristics

Terminating port impedance: $Z_0 = 50 \Omega$

Temperature: $T = -30^\circ\text{C} \dots +85^\circ\text{C}$

Supply voltage: $V_{\text{dd}} = 2.85 \text{ V} \dots 4.7 \text{ V}$

Table 3 RF Characteristics

Parameter	Symbol	Values			Unit	Note / Test Condition
		Min.	Typ.	Max.		
Insertion Loss						
TRX_1-6	IL	0.5	0.6	0.9	dB	824 to 960 MHz
TRX_1-6	IL	0.6	0.7	1.0	dB	1710 to 1980 MHz
TRX_1,4,5,6	IL	0.7	0.9	1.2	dB	1990 to 2170 MHz
TRX_2,3	IL	0.6	0.8	1.1	dB	1990 to 2170 MHz
TX_LB	IL	0.8	1.0	1.3	dB	824 to 915 MHz
TX_HB	IL	0.8	1.0	1.3	dB	1710 to 1910 MHz
Return Loss						
	RL	10	20	30	dB	824 to 960 MHz
		10	14	25	dB	1710 to 1980 MHz
		10	20	30	dB	1990 to 2170 MHz
Isolation						
	ISO	30	35	40	dB	Antenna to any TRx port
		30	35	40	dB	Between the ports TRx2, TRx4 and TRx6
		25	30	35	dB	Between any two ports
P0.1 dB Compression Point						
TX_LB	$P_{0.1\text{dB}}$	35	36	38 ¹⁾	dBm	824 to 915 MHz
TX_HB	$P_{0.1\text{dB}}$	33	35	38 ¹⁾	dBm	1710 to 1980 MHz
TRx_1-6	$P_{0.1\text{dB}}$	30	31	32	dBm	824 to 2170 MHz
Switching Time						
On/Off	$t_{\text{on/off}}$	0.5	1	3	μs	90% OFF to 90% ON; 90% ON to 90% OFF
Boost Converter Settling Time	t_{BC}	–	10	25	μs	After power down mode
Intermodulation Distortion in Rx Band						
IMD2, low	IMD2 low	-135	-115	-105	dBm	Tx = 20 dBm, Interferer = -15 dBm
IMD3	IMD3	-135	-110	-105	dBm	
IMD2, high	IMD2 high	-135	-115	-105	dBm	
Harmonic Generation up to 12.75 GHz						
TX_LB	P_{Harm}	-75	-80	-85	dBc	35 dBm, 50 Ω , 25% duty cycle
TX_HB		-73	-80	-80	dBc	33 dBm, 50 Ω , 25% duty cycle
TRX_1-6		-75	-85	-90	dBc	25 dBm, 50 Ω , 25% duty cycle

Table 3 RF Characteristics (cont'd)

Parameter	Symbol	Values			Unit	Note / Test Condition
		Min.	Typ.	Max.		
Harmonic Attenuation²⁾						
TX_LB	P_{att}	22	25	35	dB	1648 to 1830 MHz
		15	20	35	dB	2472 to 2745 MHz
		15	20	30	dB	3296 to 12750 MHz
TX_HB	P_{att}	22	30	35	dB	3420 to 3820 MHz
		21	30	38	dB	5130 to 5730 MHz
		20	25	30	dB	6840 to 12750 MHz

1) Beyond operating range, maximum rating limits exceeded.

2) Harmonic Attenuation optimization by using different values of external inductor L_{ext} . See also Application Note.

Note: All electrical characteristics are measured with all RF ports terminated in 50 Ω and recommended circuit.

5 Pin Definition and Package Outline

Table 4 Pin Configuration

Pin No.	Name	Pin Type	Buffer Type	Function
1	TRX_3			WCDMA TRX-port
2	TRX_2			WCDMA TRX-port
3	TRX_1			WCDMA TRX-port
4	GND			Ground
5	GND			Ground
6	HB_TX			High Band GSM TX-port
7	GND			Ground
8	LB_TX			Low Band GSM TX-port
9	GND			Ground
10	GND_LB			Ground Lowband
11	ANT			Antenna Port
12	GND			Ground
13	SDIO			SPI Data
14	SCL			SPI Clock
15	FRM			SPI Frame
16	LVDD			SPI Supply Voltage
17	VDD			Supply Voltage
18	TRX_6			WCDMA TRX-port
19	TRX_5			WCDMA TRX-port
20	TRX_4			WCDMA TRX-port

Table 5 Mechanical Data

Parameter	Symbol	Value	Unit
Package size	Size	3.2 x 2.8	mm
Package height	H	0.99	mm

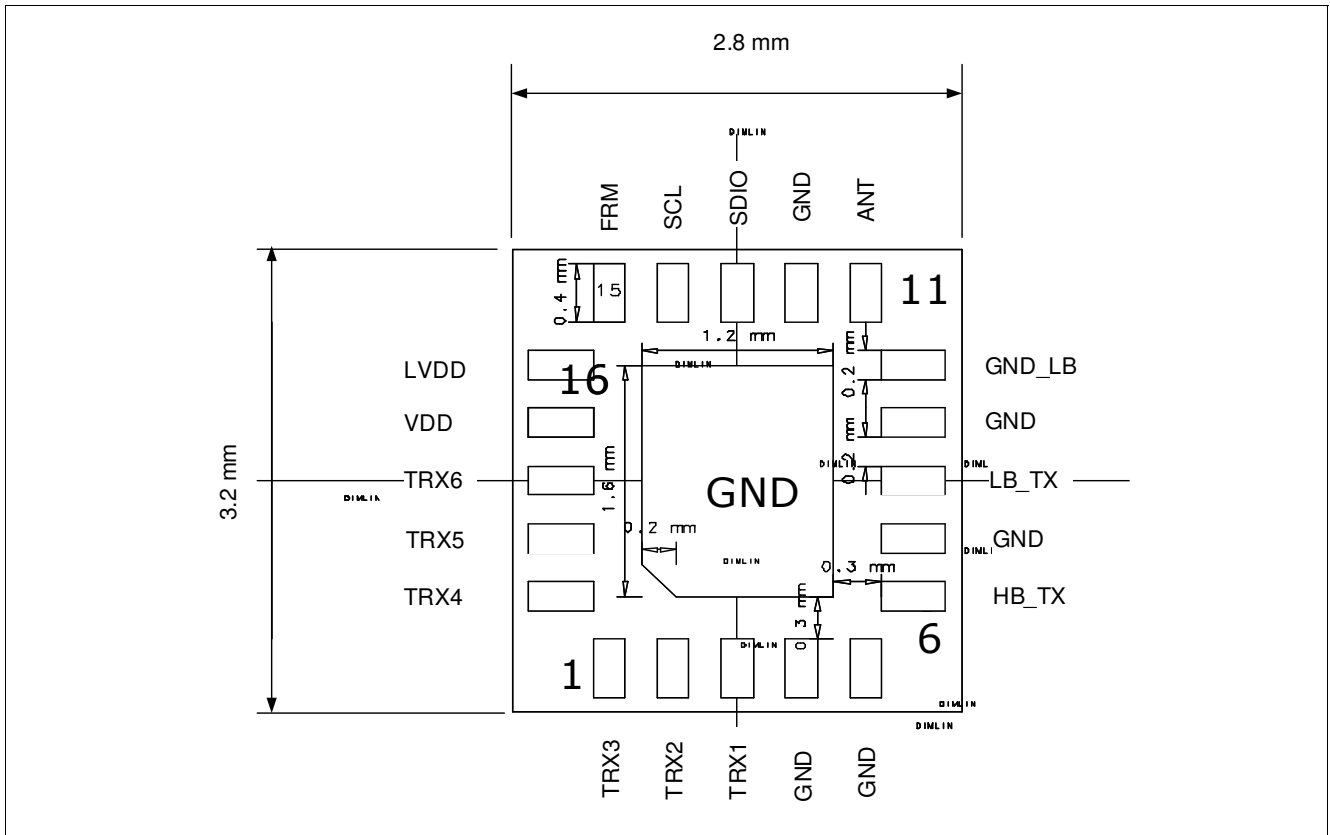

Figure 2 Pin Configuration

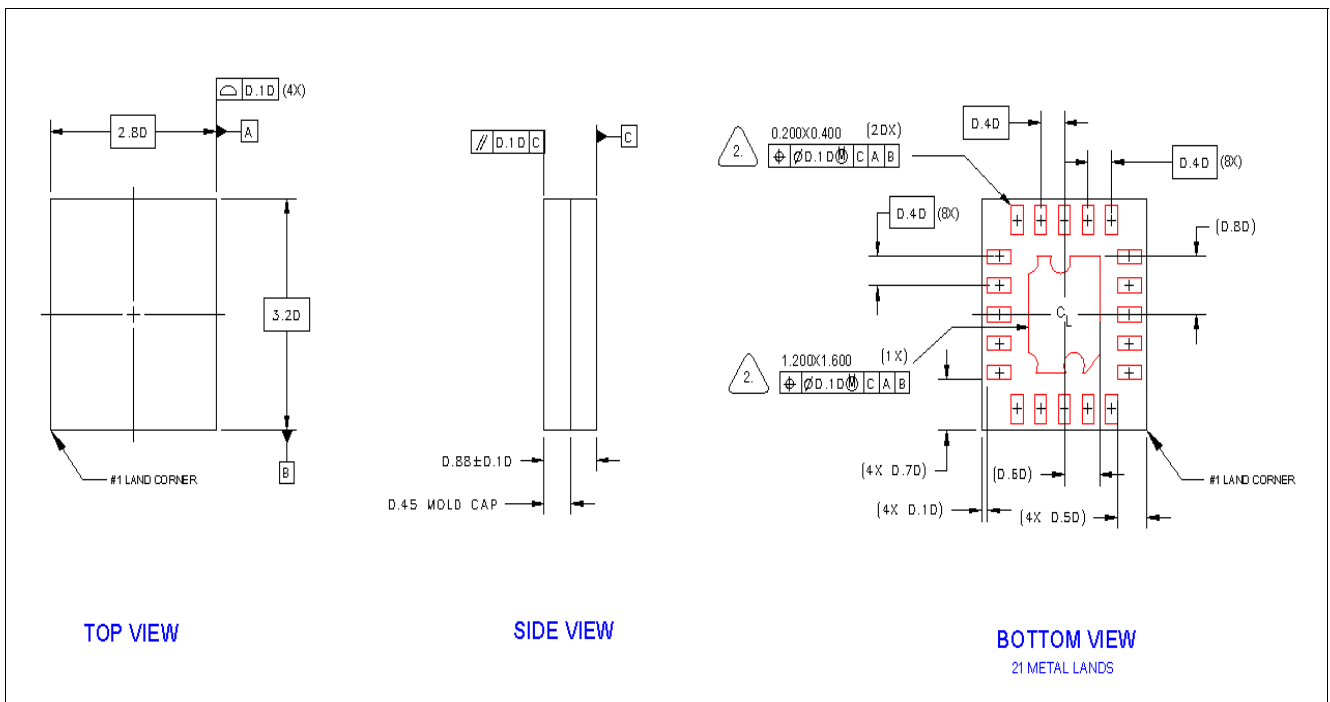

Figure 3 Package Outline

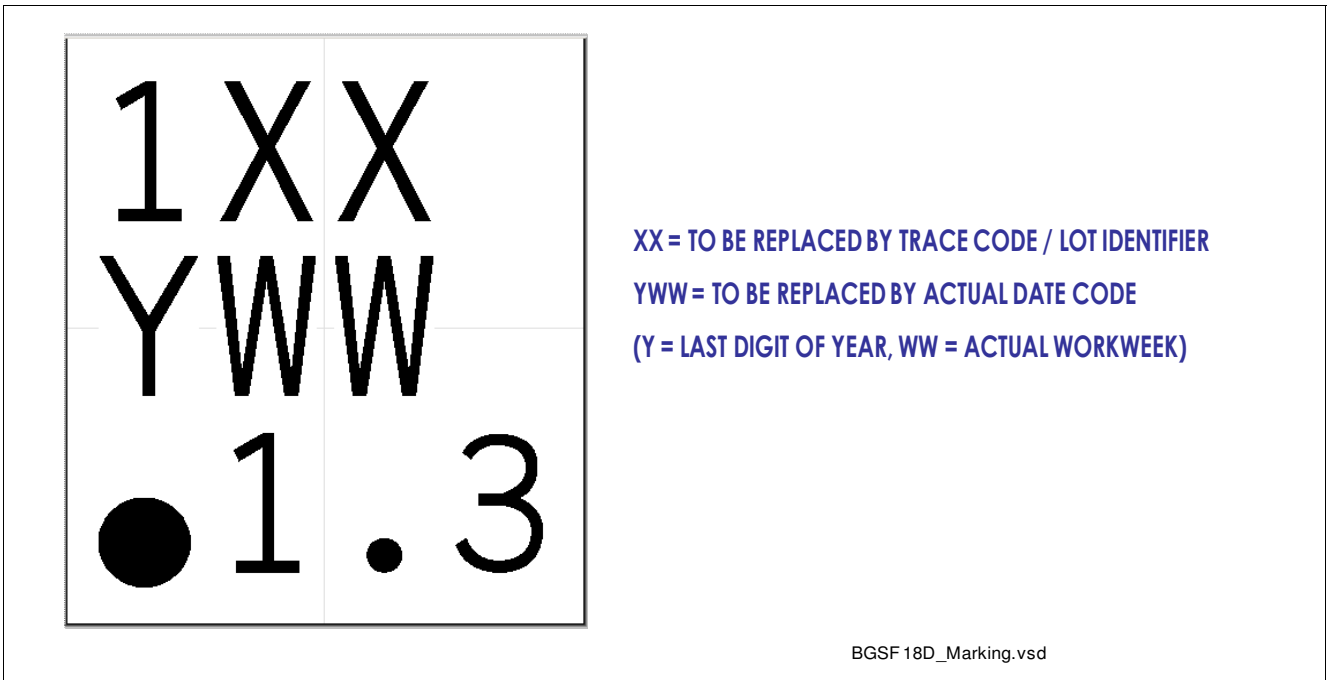

Figure 4 Laser Marking

6 SPI Command Set

Data Write																																	
29	28	27	26	25	24	23	22	21	20	19	18	17	16	15	14	13	12	11	10	9	8	7	6	5	4	3	2	1	0	Description			
R/W	Device address								Register address								Data																
1																															Read (not used)		
0																															Write		
	0	0	1	0	0	0	1	0	0	0	0	0	0																		Only 1 SPI register used		
														x						x	x	x	x	x	x	x	x	x	x	x	Bits not used		
														0	0	0	0														Switch Disabled (low current mode)		
														0	0	0	1														GSM HB_TX		
														0	0	1	0														GSM LB_TX		
														0	1	0	0														TRX1		
														0	1	0	1														TRX2		
														0	1	1	0														TRX3		
														1	0	0	0														TRX4		
														1	0	0	1														TRX5		
														1	0	1	0														TRX6		
														1	1	1	1														Isolation state		
Global Write																																	
29	28	27	26	25	24	23	22	21	20	19	18	17	16	15	14	13	12	11	10	9	8	7	6	5	4	3	2	1	0	Description			
R/W	Device address								Register address								Data																
0	1	1	1	1	1	1	1	1	1	1	1	1	1	x	x	x	x	x	x	x	x	x	x	x	x	x	x	x	x	x	Standby Mode		

Figure 5 SPI Command Set

www.infineon.com

Published by Infineon Technologies AG