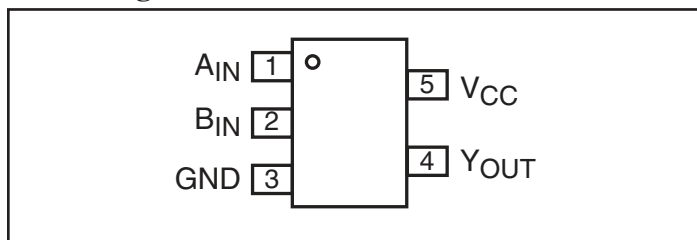
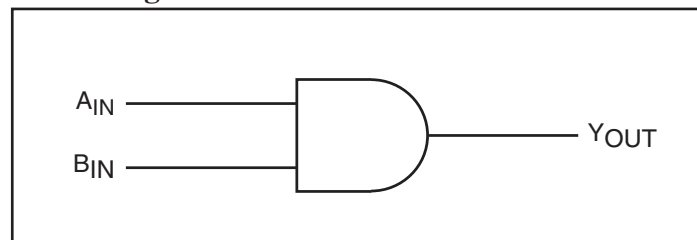

**Features**

- High-speed:  $t_{PD} = 1.8\text{ns}$  typical
- Broad operating range:  $V_{CC} = 1.8\text{V} - 3.6\text{V}$
- Power down high-impedance inputs/outputs
- High output drive:  $\pm 24\text{mA}$  at  $3\text{V } V_{CC}$
- Packaging (Pb-free & Green available):
  - 5-pin SOT23 (T)
  - 5-pin SC70 (C)

**Description**

The PI74ST1G08 is a 2-Input AND Gate that operates over the 1.8V to 3.6V  $V_{CC}$  operating range.

**Pin Configuration**

**Block Diagram**

**Pin Description**

Pin Name	Description
$A_{IN}$	Input
$B_{IN}$	Input
$Y_{OUT}$	Output

**Recommended Operating Conditions<sup>(1)</sup>**

Parameter	Condition	Min.	Max.	Units
Supply Voltage ( $V_{CC}$ )		1.8	3.6	V
Input Voltage ( $V_{IN}$ )		0	5.5	
Output Voltage ( $V_{OUT}$ )		0	$V_{CC}$	
Operating Temperature		-40	85	°C
Input Rise and Fall Time ( $t_r, t_f$ )	$V_{CC} = 1.8\text{V}, 2.5\text{V} \pm 0.2\text{V}$	0	20	ns/V
	$V_{CC} = 3.3\text{V} \pm 0.3\text{V}$	0	10	

**Function Table**

Inputs		Outputs
$A_{IN}$	$B_{IN}$	$Y_{OUT}$
L	L	L
L	H	L
H	L	L
H	H	H

**Notes:**

- H = HIGH Logic Level
- L = LOW Logic Level

**Notes:**

1. Unused inputs must be held HIGH or LOW. They may not float.

**Absolute Maximum Ratings**

Supply Voltage (V <sub>CC</sub> )	-0.5V to +4V
DC Input Voltage (V <sub>IN</sub> )	-0.5V to +6V
DC Output Voltage (V <sub>OUT</sub> )	-0.5V to +6V
DC Input Diode Current (I <sub>IK</sub> )	-50mA to 20mA
DC Output Diode Current (I <sub>OK</sub> )	-50mA to 20mA
DC Output Current (I <sub>OUT</sub> )	±50mA
DC V <sub>CC</sub> /GND Current (I <sub>CC</sub> /I <sub>GND</sub> )	±50mA
Storage Temperature (T <sub>STG</sub> )	-65°C to +150°C
Junction Lead Temperature (I <sub>OS</sub> )	200°C
Power Dissipation SOT23	200mW
SC70	150mW

**Note:**

Absolute maximum ratings are DC values beyond which the device may be damaged or have its useful life impaired. The datasheet specifications should be met, without exception, to ensure that the system design is reliable over its power supply, temperature, and output/input loading variables. Pericom does not recommend operation outside datasheet specifications.

**DC Electrical Characteristics** (Over supply voltage and operating temperature ranges, unless otherwise specified)

Symbol	Parameter	V <sub>CC</sub> (V)	Conditions	T <sub>A</sub> = +25°C			T <sub>A</sub> = -40° C to +85°C		Units	
				Min.	Typ.	Max.	Min.	Max.		
V <sub>IH</sub>	HIGH Level Input Voltage	1.8 2.3-3.6		0.75V <sub>CC</sub> 0.70V <sub>CC</sub>			0.75V <sub>CC</sub> 0.70V <sub>CC</sub>		V	
V <sub>IL</sub>	LOW Level Input Voltage	1.8 2.3-3.6				0.25V <sub>CC</sub> 0.30V <sub>CC</sub>		0.25V <sub>CC</sub> 0.30V <sub>CC</sub>		
V <sub>OH</sub>	HIGH Level Output Voltage	1.8	V <sub>IN</sub> = V <sub>IH</sub>	I <sub>OH</sub> = -100μA	1.7	1.79		1.7		
		2.3			2.2	2.29		2.2		
		3.0			2.9	2.99		2.9		
V <sub>OH</sub>	HIGH Level Output Voltage	2.3		I <sub>OH</sub> = -8mA I <sub>OH</sub> = -16mA I <sub>OH</sub> = -24mA	1.9	2.13		1.9		
		3.0			2.4	2.71		2.4		
		3.0			2.3	2.55		2.3		
V <sub>OL</sub>	LOW Level Out-put Voltage	1.8	V <sub>IN</sub> = V <sub>IL</sub>	I <sub>OL</sub> = 100μA		0.01	0.1			0.1
		2.3				0.01	0.1			0.1
		3.0				0.00	0.1		0.1	
		2.3			I <sub>OH</sub> = 8mA I <sub>OH</sub> = 16mA I <sub>OH</sub> = 24mA	0.10	0.3		0.3	
3.0	0.18	0.4		0.4						
3.0	0.28	0.55		0.55						
I <sub>IN</sub>	Input Leakage Current	0-3.6	V <sub>IN</sub> = 5.5V, GND	-1		1	-1	1	μA	
I <sub>OFF</sub>	Power Off Leakage Current	0.0	V <sub>IN</sub> or V <sub>OUT</sub> = 5.5V	-1		1	-1	1		
I <sub>CC</sub>	Quiescent Supply Current	1.8-3.6	V <sub>IN</sub> = 5.5V, GND		2.0			20		

### AC Electrical Characteristics

Symbol	Parameter	V <sub>CC</sub> (V)	Conditions	T <sub>A</sub> = +25°C			T <sub>A</sub> = -40° C to +85°C		Units	Fig. No.
				Min.	Typ.	Max.	Min.	Max.		
t <sub>PLH</sub> t <sub>PHL</sub>	Propagation Delay	1.8 2.5±0.2 3.3±0.3	C <sub>L</sub> = 15pF, R <sub>L</sub> = 1MΩ	2.2 0.8 0.5	3.0 1.9 1.3	4.0 2.6 2.2	2.0 0.8 0.5	4.4 2.8 2.5	ns	1 3
t <sub>PLH</sub> t <sub>PHL</sub>	Propagation Delay	3.3±0.3	C <sub>L</sub> = 50pF, R <sub>L</sub> = 500Ω	1.5	2.9	3.8	1.5	4.2		1 3
C <sub>IN</sub>	Input Capacitance	V <sub>IN</sub> = 0			4				pF	
C <sub>PD</sub> <sup>(1)</sup>	Power Dissipation Capacitance	3.3	Note 3		20					2

#### Notes:

- C<sub>PD</sub> is defined as the value of the internal equivalent capacitance which is derived from dynamic operating current consumption (I<sub>CCD</sub>) at no output loading and operating at 50% duty cycle (see Figure 2). C<sub>PD</sub> is related to I<sub>CCD</sub> dynamic operating current by the expression:

$$I_{CCD} = (C_{PD})(V_{CC})(f_{IN}) + (I_{CC} \text{ static}).$$

### AC Loading and Waveforms

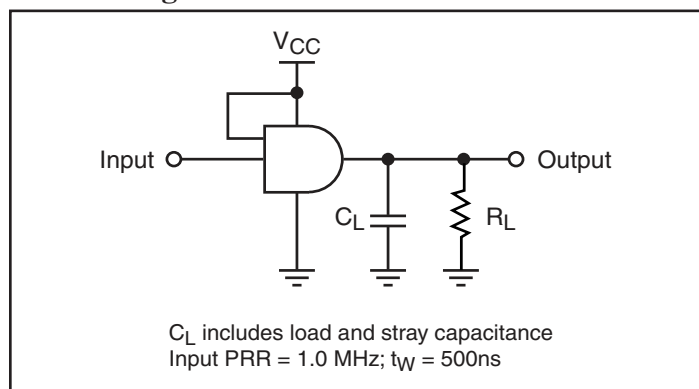

Figure 1. AC Test Circuit

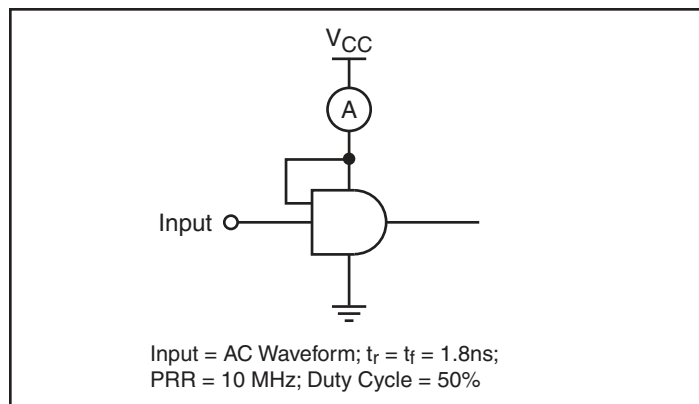

Figure 2. I<sub>CCD</sub> Test Circuit

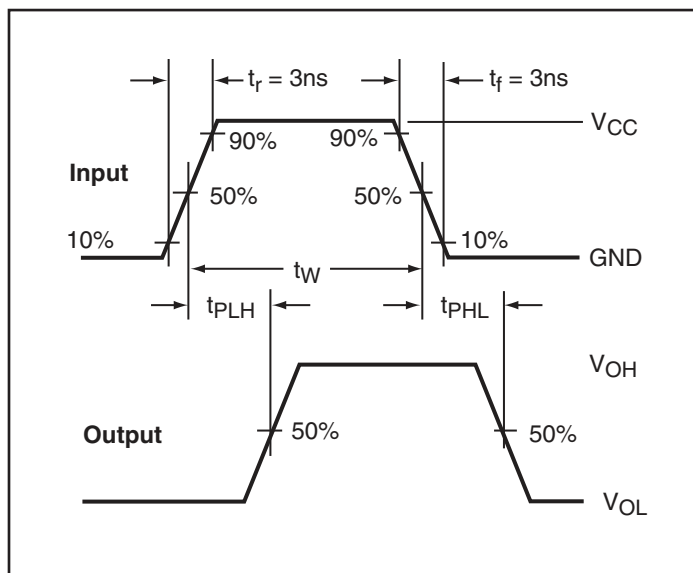
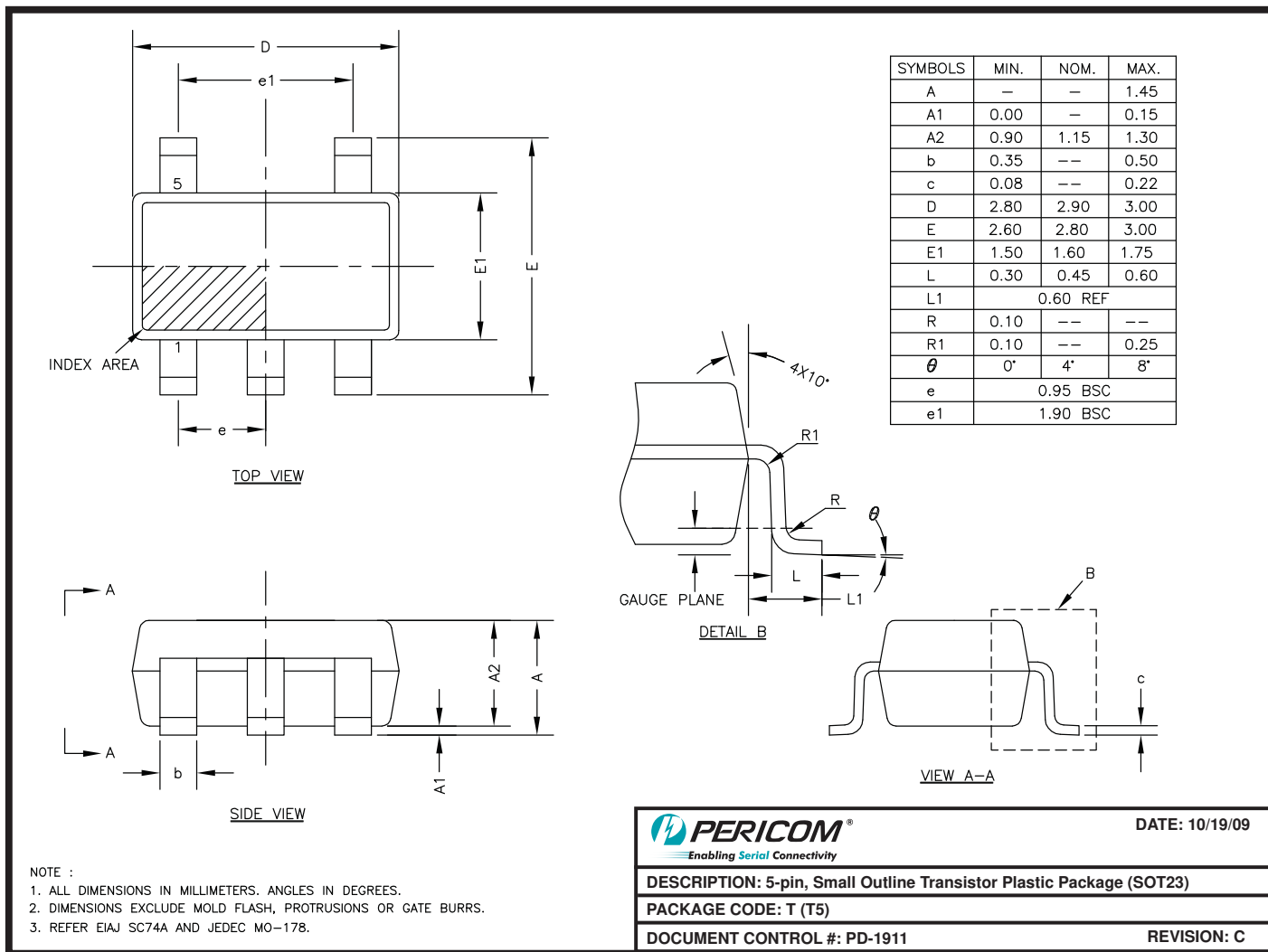
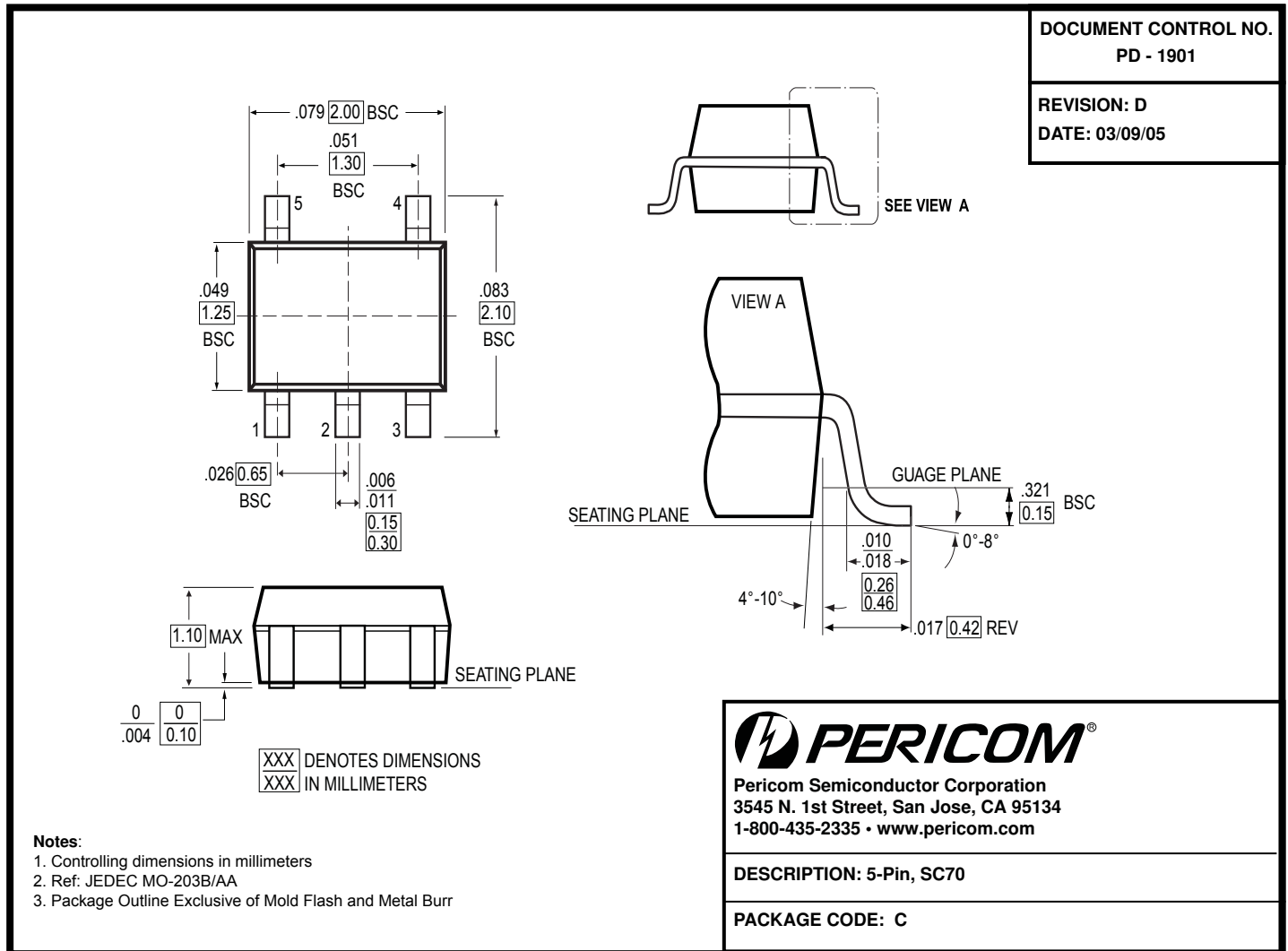

Figure 3. AC Waveforms



09-0130

**Note:**

- For latest package info, please check: <http://www.pericom.com/products/packaging/mechanicals.php>

**Ordering Information**

Ordering Code	Package Code	Package Description	Top Marking
PI74ST1G08TEX	T	Pb-free & Green, 5-pin SOT23	A8
PI74ST1G08CEX	C	Pb-free & Green, 5-pin SC70	A8

**Notes:**

- Thermal characteristics can be found on the company web site at [www.pericom.com/packaging/](http://www.pericom.com/packaging/)
- E = Pb-free and Green
- X Suffix = Tape and Reel