

FEATURES

- Drives 6 LEDs from 2.6 V to 5.5 V (Li-Ion) input supply
- 1×/1.5×/2× fractional charge pump to maximize power efficiency
- 1% maximum LED current matching
- Up to 88% power efficiency over Li-Ion range
- Powers main and sub display LEDs with individual shutdown
- Package footprint only 9 mm² (3 mm × 3 mm)
- Package height only 0.75 mm
- Low power shutdown mode
- Shutdown function
- Soft-start limiting in-rush current

APPLICATIONS

- Cellular phones with main and sub displays
- White LED backlighting
- Camera flash/strobes and movie lights
- Micro TFT color displays
- DSC
- PDA's

GENERAL DESCRIPTION

The ADM8845 uses charge pump technology to provide the power required to drive up to six LEDs. The LEDs are used for backlighting a color LCD display, having regulated constant current for uniform brightness intensity. The main display can have up to four LEDs, and the sub display can have one or two LEDs. The digital CTRL1 and CTRL2 input control pins control the shutdown operation and the brightness of the main and sub displays.

To maximize power efficiency, the charge pump can operate in a 1×, 1.5×, or 2× mode. The charge pump automatically switches between 1×/1.5×/2× modes, based on the input voltage, to maintain sufficient drive for the LED anodes at the highest power efficiency.

Improved brightness matching of the LEDs is achieved by a feedback pin to sense individual LED current with a maximum matching accuracy of 1%.

FUNCTIONAL BLOCK DIAGRAM

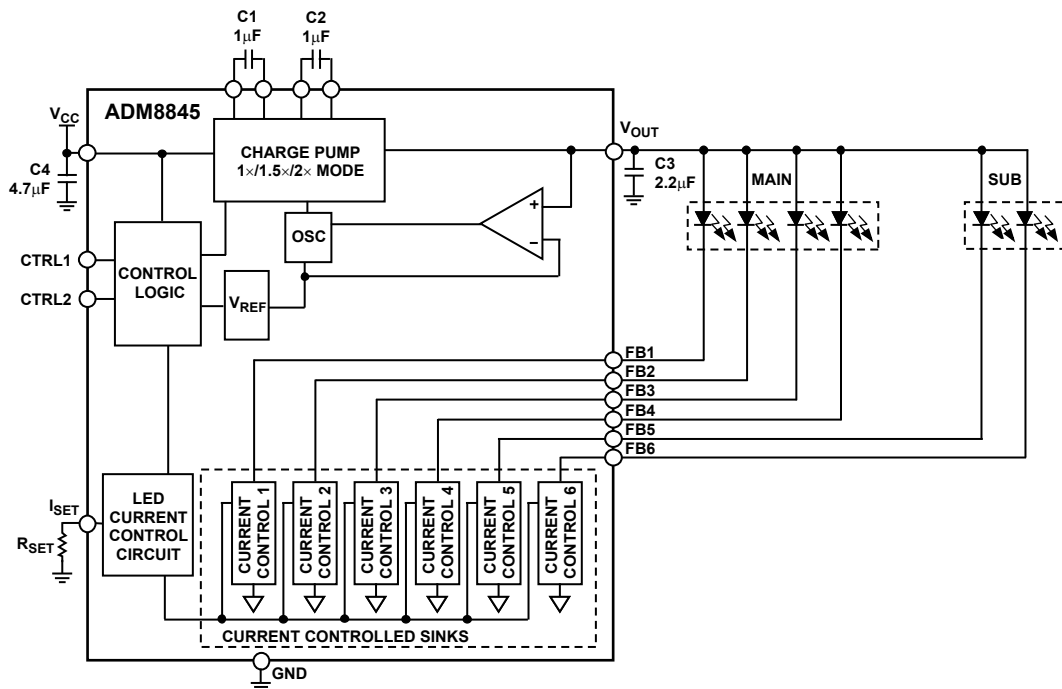

Figure 1.

04887-0-001

Rev. D

[Document Feedback](#)

Information furnished by Analog Devices is believed to be accurate and reliable. However, no responsibility is assumed by Analog Devices for its use, nor for any infringements of patents or other rights of third parties that may result from its use. Specifications subject to change without notice. No license is granted by implication or otherwise under any patent or patent rights of Analog Devices. Trademarks and registered trademarks are the property of their respective owners.

One Technology Way, P.O. Box 9106, Norwood, MA 02062-9106, U.S.A.
Tel: 781.329.4700 ©2004–2018 Analog Devices, Inc. All rights reserved.
[Technical Support](#) www.analog.com

TABLE OF CONTENTS

Features	1
Applications	1
General Description	1
Functional Block Diagram	1
Revision History	2
Specifications	3
Absolute Maximum Ratings	4
Thermal Resistance	4
ESD Caution	4
Pin Configuration and Function Descriptions	5
Typical Performance Characteristics	6
Theory of Operation	10
Output Current Capability	11
Automatic Gain Control	11
Current Matching	11
Brightness Control with a Digital PWM Signal	11

REVISION HISTORY

5/2018—Rev. C to Rev. D

Changes to Features Section	1
Add Thermal Resistance Section	4
Changes to Figure 2	5
Updated Outline Dimensions	18
Changes to Ordering Guide	18

1/2011—Rev. B to Rev. C

Changes to Figure 18 and Figure 19	8
Changes to Ordering Guide	18

4/2010—Rev. A to Rev. B

Changes to Figure 2	5
Changes to Figure 4	6

LED Brightness Control Using a PWM Signal Applied to V_{PWM}	13
LED Brightness Control Using a DC Voltage Applied to V_{BRIGHT}	13
Applications Information	14
Layout Considerations and Noise	14
White LED Shorting	14
Driving Fewer than Six LEDs	14
Driving Flash LEDs	15
Driving Camera Light, Main, and Sub LEDs	15
Driving Four Backlight White LEDs and Flash LEDs	16
Power Efficiency	17
Outline Dimensions	18
Ordering Guide	18

Changes to Figure 16 to Figure 19	8
Changes to Brightness Control with a Digital PWM Signal Section	11
Added Exposed Pad Notation to Outline Dimensions	18
Changes to Ordering Guide	18

7/2005—Rev. 0 to Rev. A

Changes to Table 3	5
Changes to Table 7	12
Updated Outline Dimensions	18
Changes to Ordering Guide	18

10/2004—Revision 0: Initial Version

SPECIFICATIONS

$V_{CC} = 2.6\text{ V to }5.5\text{ V}$, $T_A = -40^\circ\text{C to }+85^\circ\text{C}$, unless otherwise noted. $C_1, C_2 = 1.0\ \mu\text{F}$, $C_3 = 2.2\ \mu\text{F}$, and $C_4 = 4.7\ \mu\text{F}$.

Table 1.

Parameter	Min	Typ	Max	Unit	Test Conditions
INPUT VOLTAGE, V_{CC}	2.6		5.5	V	
SUPPLY CURRENT, I_{CC}		2.6	5	mA	All six LEDs disabled, $V_{CC} = 3.3\text{ V}$, $R_{SET} = 7.08\text{ k}\Omega$, $CTRL1 = 1$, $CRTL2 = 1$
SHUTDOWN CURRENT			5	μA	
CHARGE PUMP FREQUENCY		1.5		MHz	
CHARGE PUMP MODE THRESHOLDS					
1.5x to 2x		3.33		V	
Accuracy			4	%	
2x to 1.5x		3.36		V	
Accuracy			4	%	
Hysteresis		40		mV	
1x to 1.5x		4.77		V	
Accuracy			4	%	
1.5x to 1x		4.81		V	
Accuracy			4	%	
Hysteresis		40		mV	
I_{SET} PIN					
LED					
LED Matching	-1		+1	%	$I_{LED} = 20\text{ mA}$, $V_{FB} = 0.4\text{ V}$
I_{SET} Accuracy	-1		+1	%	$I_{LED} = 20\text{ mA}$, $R_{SET} = 7.08\text{ k}\Omega$, $V_{FB} = 0.4\text{ V}$, $V_{CC} = 3.6\text{ V}$, $T_A = 25^\circ\text{C}$
I_{SET} Pin Voltage		1.18		V	
I_{LED} to I_{SET} Ratio		120			
MIN COMPLIANCE ON FBx PIN		0.2	0.3	V	$I_{SET} = 20\text{ mA}$
Charge Pump Output Resistance		1.2	1.8	Ω	1x mode
		3.5	5.1	Ω	1.5x mode
		8.0	14	Ω	2x mode
LED Current			30	mA	Guaranteed by design. Not 100% production tested. See Figure 21.
PWM	0.1		200	kHz	
DIGITAL INPUTS					
Input High	0.5 V_{CC}			V	
Input Low			0.3 V_{CC}	V	
Input Leakage Current			1	μA	
CHARGE PUMP POWER EFFICIENCY		88		%	$CTRL1 = 1$, $CRTL2 = 1$, $V_{CC} = 3.4\text{ V}$, $V_{FB} = 0.2\text{ V}$, $I_{FB} = 20\text{ mA}$
V_{OUT} RIPPLE		30		mV	$V_{CC} = 3.6\text{ V}$, $I_{LED} = 20\text{ mA}$, all six LEDs enabled

ABSOLUTE MAXIMUM RATINGS

$T_A = 25^\circ\text{C}$, unless otherwise noted.

Table 2.

Parameter	Rating
Supply Voltage, V_{CC}	-0.3 V to +6.0 V
I_{SET}	-0.3 V to +2.0 V
CTRL1, CTRL2	-0.3 V to +6.0 V
V_{OUT} Shorted ¹	Indefinite
Feedback Pins FB1 to FB6	-0.3 V to +6.0 V
Operating Temperature Range	
Six LEDs Enabled with 30 mA/LED ²	-40°C to +65°C
Six LEDs Enabled with 20 mA/LED ²	-40°C to +85°C
V_{OUT} ³	180 mA
Storage Temperature Range	-65°C to +125°C
Power Dissipation	2 mW
Electrostatic Discharge (ESD) Class	1

¹ Short through LED.

² LED current should be derated above $T_A > 65^\circ\text{C}$, refer to Figure 21.

³ Based on long-term current density limitations.

Stresses at or above those listed under Absolute Maximum Ratings may cause permanent damage to the product. This is a stress rating only; functional operation of the product at these or any other conditions above those indicated in the operational section of this specification is not implied. Operation beyond the maximum operating conditions for extended periods may affect product reliability.

THERMAL RESISTANCE

Thermal resistance values specified in Table 3 are simulated based on JEDEC specifications, unless specified otherwise, and must be used in compliance with JESD51-12.

Table 3. Thermal Resistance

Package Type	θ_{JA}	θ_{JC} ¹	θ_{JB}	Ψ_{JT}	Ψ_{JB}	Unit
CP-16-22 ²	39.25	7.5	17.4	0.8	12.4	$^\circ\text{C}/\text{W}$

¹ For θ_{JC} , 100 μm thermal interface material is used. Thermal interface material is assumed to have 3.6 W/mK.

² Using enhanced heat removal (printed circuit board (PCB), heat sink, and airflow) techniques improves thermal resistance values.

ESD CAUTION



ESD (electrostatic discharge) sensitive device.

Charged devices and circuit boards can discharge without detection. Although this product features patented or proprietary protection circuitry, damage may occur on devices subjected to high energy ESD. Therefore, proper ESD precautions should be taken to avoid performance degradation or loss of functionality.

PIN CONFIGURATION AND FUNCTION DESCRIPTIONS

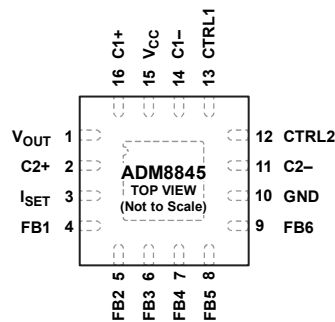

NOTES
1. CONNECT EXPOSED PADDLE TO GND.

04867-0-003

Figure 2. Pin Configuration

Table 4. Pin Function Descriptions

Pin No.	Mnemonic	Function
1	V _{OUT}	Charge Pump Output. A 2.2 μF capacitor to ground is required on this pin. Connect V _{OUT} to the anodes of all the LEDs.
2	C2+	Flying Capacitor 2 Positive Connection.
3	I _{SET}	Bias Current Set Input. The current, I _{SET} , flowing through the resistor, R _{SET} , is gained up by 120 to give the I _{LED} current. Connect R _{SET} to GND to set the bias current as V _{SET} /R _{SET} . Note that V _{SET} = 1.18 V.
4 to 9	FB1 to FB6	LED1 to LED6 Cathode Connection and Charge Pump Feedback. The current, I _{SET} , flowing in these LEDs is 120 times the current flowing through resistor, R _{SET} . When using fewer than six LEDs, this pin can be left unconnected or connected to GND.
10	GND	Device Ground Pin.
11	C2-	Flying Capacitor 2 Negative Connection.
12	CTRL2	Digital Input. 3 V CMOS Logic. Used with CTRL1 to control the shutdown operation of the main and sub LEDs.
13	CTRL1	Digital Input. 3 V CMOS Logic. Used with CTRL2 to control the shutdown operation of the main and sub LEDs.
14	C1-	Flying Capacitor 1 Negative Connection.
15	V _{CC}	Positive Supply Voltage Input. Connect this pin to a 2.6 V to 5.5 V supply with a 4.7 μF decoupling capacitor.
16	C1+	Flying Capacitor 1 Positive Connection.
	EP	Exposed Paddle. Connect the exposed paddle to GND.

TYPICAL PERFORMANCE CHARACTERISTICS

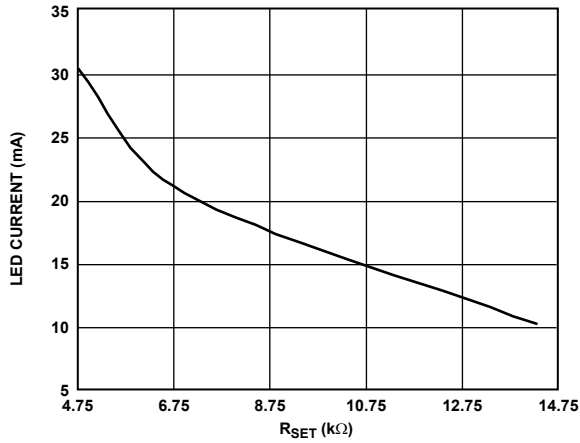

Figure 3. LED Current vs. R_{SET}

04867-0-004

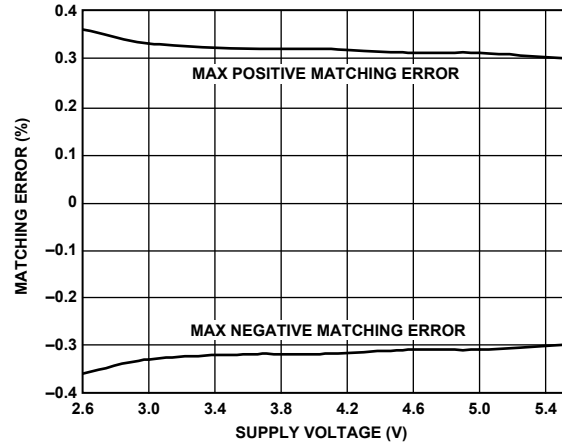

Figure 6. I_{LED} Matching Error vs. Supply Voltage, $T_A = 25^\circ C$ and $I_{LED} = 20\text{ mA}$

04867-0-007

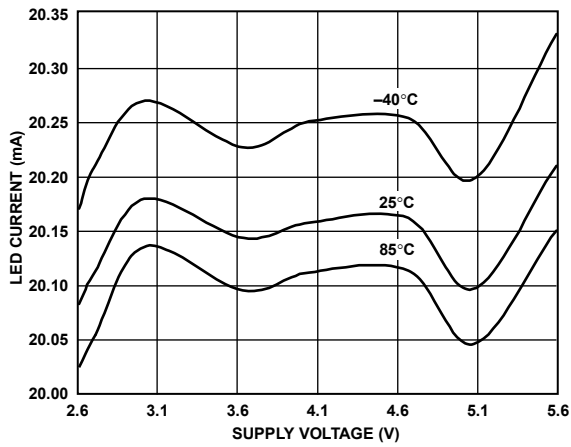

Figure 4. LED Current vs. Supply Voltage Over Various Temperatures, Six LEDs Enabled

04867-0-005

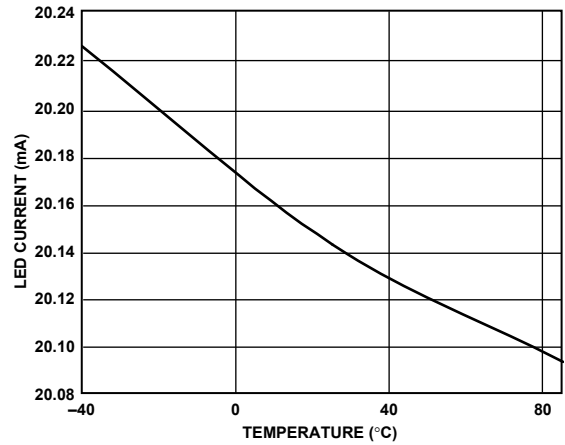

Figure 7. LED Current Variation over Temperature, $V_{CC} = 3.6\text{ V}$

04867-0-008

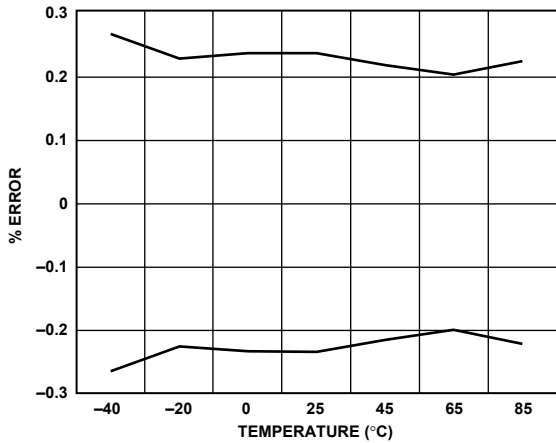

Figure 5. LED Current Matching over Temperature, $V_{CC} = 3.6\text{ V}$, $I_{LED} = 20\text{ mA}$, Six LEDs Enabled

04867-0-006

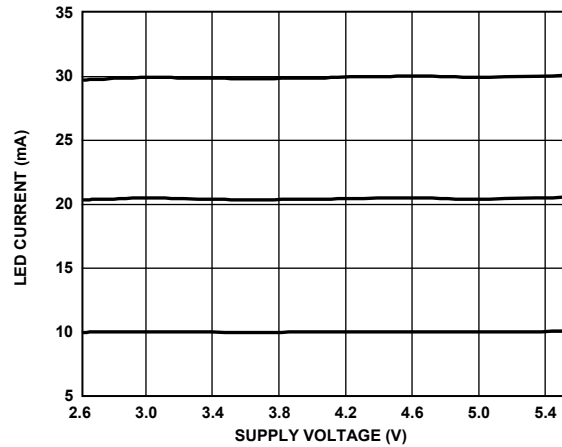

Figure 8. LED Current vs. Supply Voltage

04867-0-009

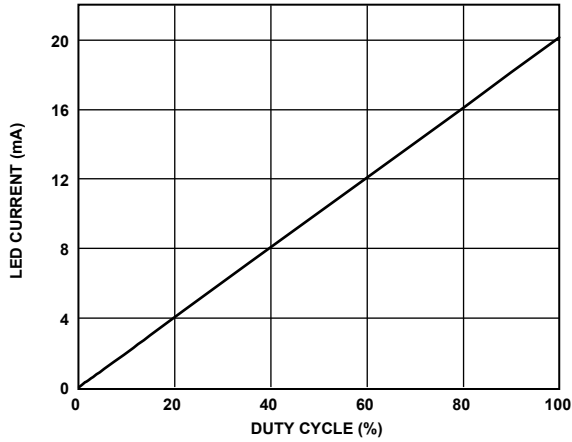

Figure 9. LED Current vs. PWM Dimming (Varying Duty Cycle), Six LEDs Enabled, Frequency = 1 kHz

04887-0-010

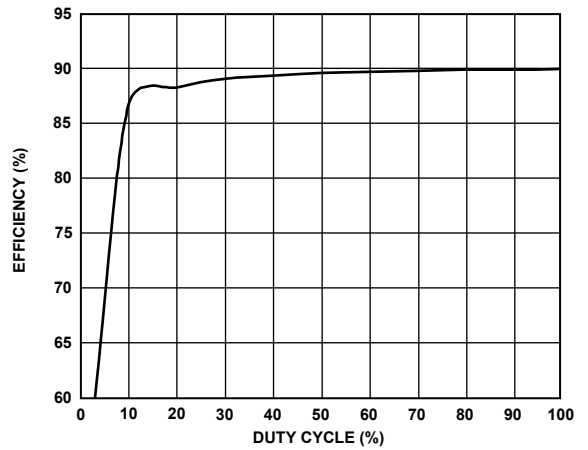

Figure 12. LED Efficiency vs. Varying Duty Cycle of 1 kHz PWM Signal, Six LEDs Enabled, 20 mA/LED

04887-0-013

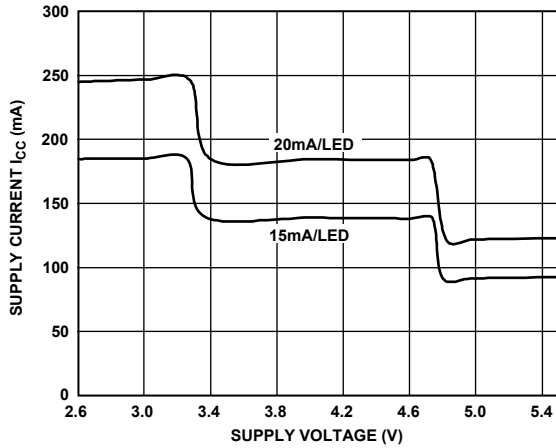

Figure 10. Supply Current I_{CC} vs. Supply Voltage, Six LEDs Enabled

04887-0-011

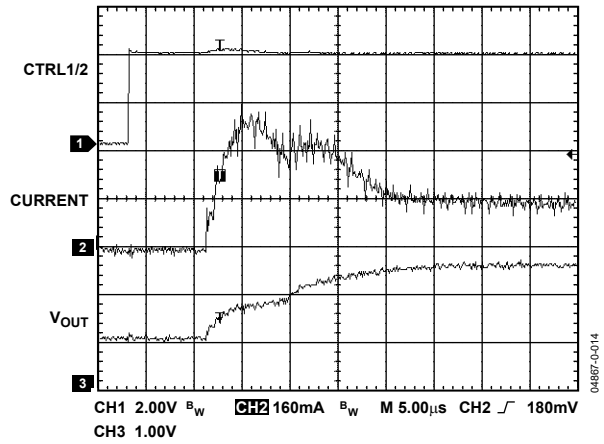

Figure 13. Soft Start Showing the Initial In-Rush Current and V_{OUT} Variation, Six LEDs at 20 mA/LED, $V_{CC} = 3.6 V$

04887-0-014

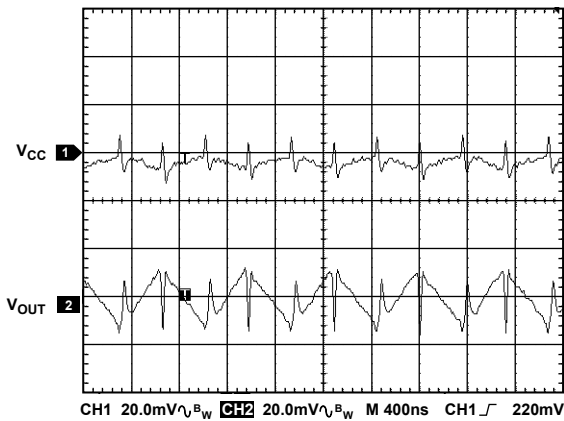

Figure 11. 1.5x Mode Operating Waveforms

04887-0-012

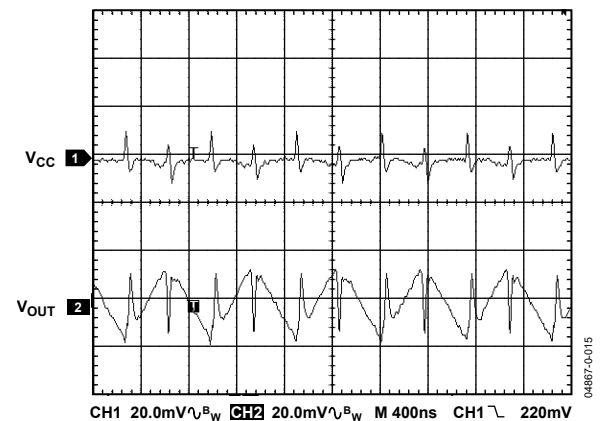

Figure 14. .2x Mode Operating Waveform

04887-0-015

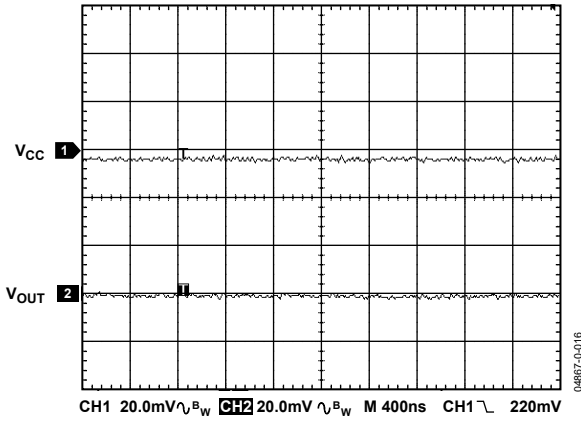

Figure 15. 1x Mode Operating Waveforms

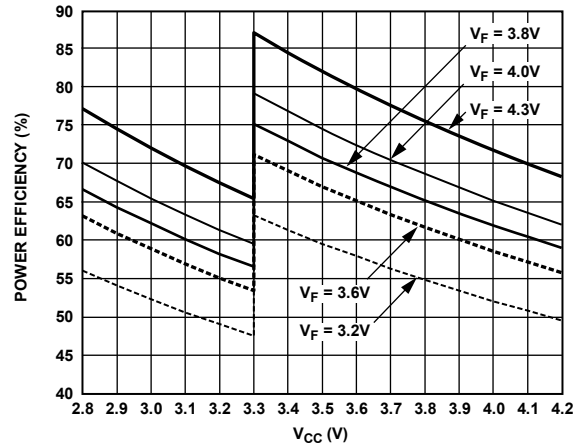

Figure 18. Power Efficiency vs. V_{CC} over Li-Ion Range, Six LEDs at 20 mA/LED

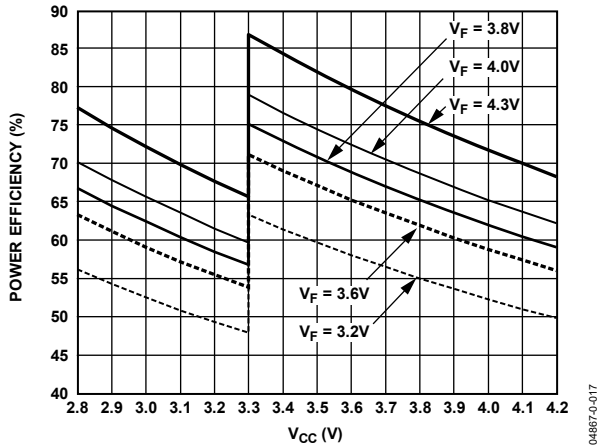

Figure 16. Power Efficiency vs. V_{CC} over Li-Ion Range, Six LEDs at 15 mA/LED

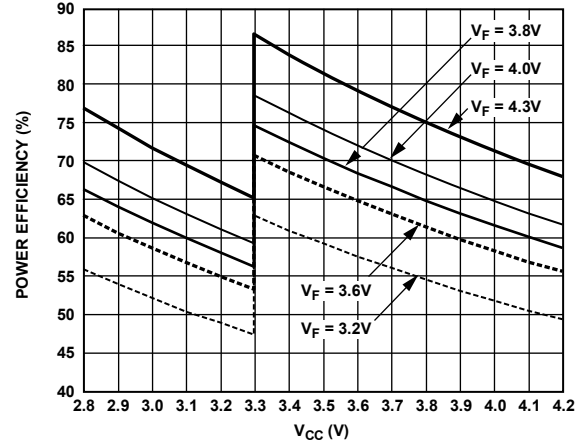

Figure 19. Power Efficiency vs. V_{CC} over Li-Ion Range, Four LEDs at 20 mA/LED

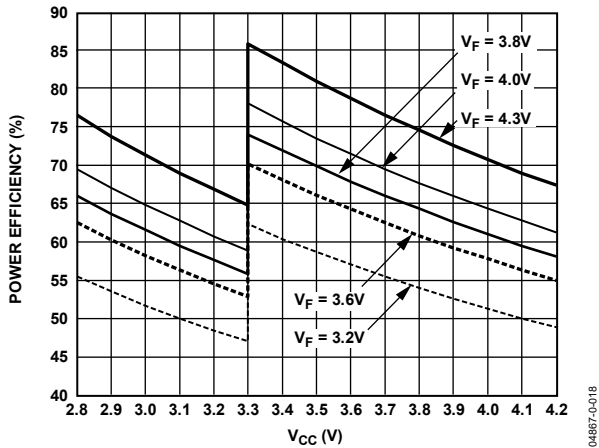

Figure 17. Power Efficiency vs. V_{CC} over Li-Ion Range, Four LEDs at 15 mA/LED

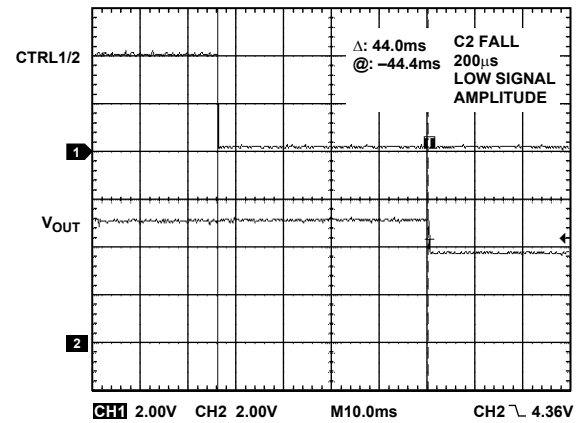

Figure 20. TPC Delay

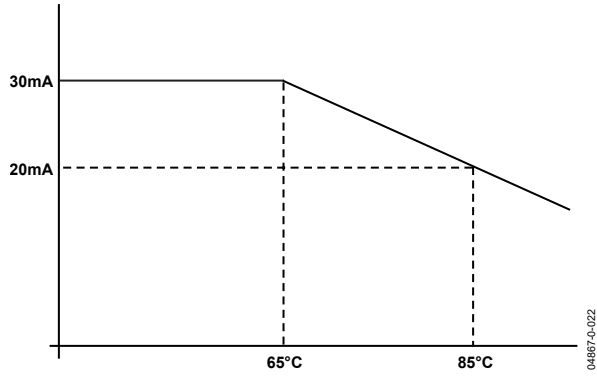

Figure 21. Maximum I_{LED} vs. Ambient Temperature, Six LEDs Connected

THEORY OF OPERATION

The ADM8845 charge pump driver for LCD white LED backlights implements a multiple gain charge pump (1×, 1.5×, 2×) to maintain the correct voltage on the anodes of the LEDs over a 2.6 V to 5.5 V (Li-Ion) input supply voltage. The charge pump automatically switches between 1×/1.5×/2× modes, based on the input voltage, to maintain sufficient drive for the LED anodes, with V_{CC} input voltages as low as 2.6 V. It also includes regulation of the charge pump output voltage for supply voltages up to 5.5 V. The six LEDs of the ADM8845 are arranged into two groups, main and sub. The main display can have up to four LEDs, FB1 to FB4, and the sub display can have one or two LEDs, FB5 and FB6 (see Figure 23). Two digital input control pins, CTRL1 and CTRL2, control the shutdown operation and the brightness of the main and sub displays (see Table 5).

Table 5. Shutdown Truth Table

CTRL1	CTRL2	LED Shutdown Operation
0	0	Sub display off/main display off
0	1	Sub display off/main display on
1	0	Sub display on/main display off
1	1	Sub display on/main display on

An external resistor, R_{SET} , is connected between the I_{SET} pin and GND. This resistor sets up a reference current, I_{SET} , which is internally gained up by 120 within the ADM8845 to produce the I_{LED} currents of up to 30 mA/LED ($I_{LED} = I_{SET} \times 120$ and $I_{SET} = 1.18 \text{ V}/R_{SET}$). The ADM8845 uses six individual current sinks to individually sense each LED current with a maximum matching performance of 1%. This current matching performance ensures uniform brightness across a color display.

The ADM8845 lets the user control the brightness of the white LEDs with a digital PWM signal applied to CTRL1 and/or CTRL2. The duty cycle of the applied PWM signal determines the brightness of the main and/or sub display backlight white LEDs. The ADM8845 also allows the brightness of the white LEDs to be controlled using a dc voltage (see Figure 22). Soft-start circuitry limits the in-rush current flow at power-up. The ADM8845 is fabricated using CMOS technology for minimal power consumption and is packaged in a 16-lead lead frame chip scale package.

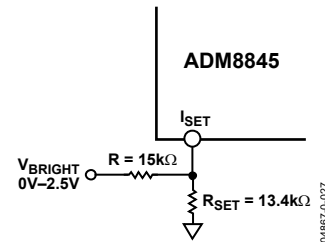

Figure 22. PWM Brightness Control Using a DC Voltage Applied to V_{BRIGHT}

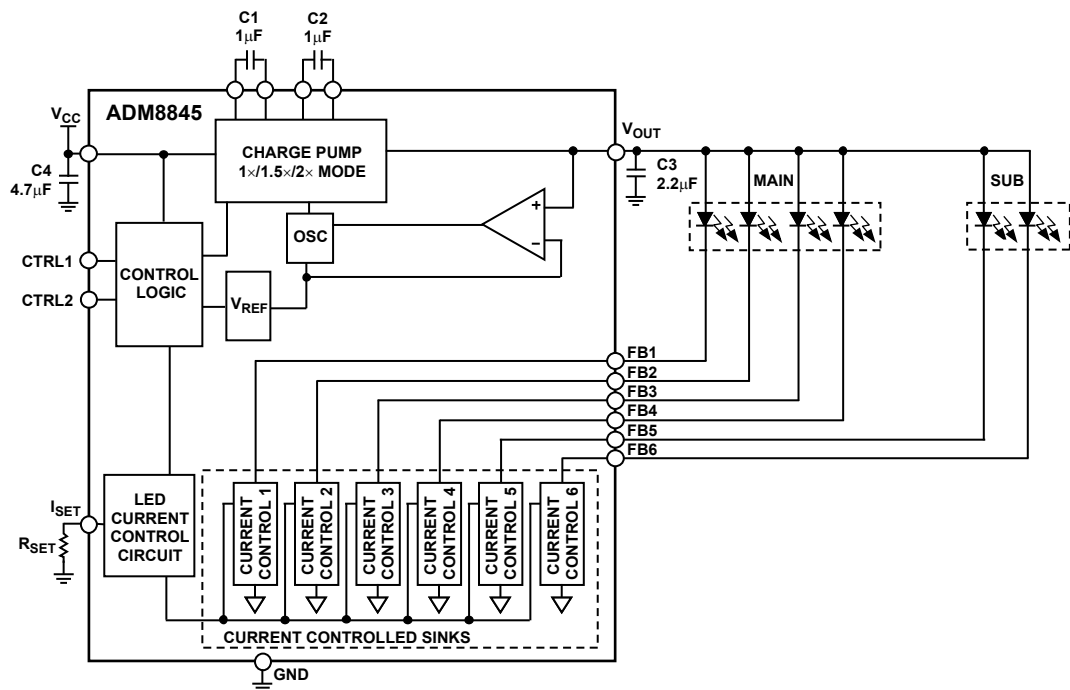

Figure 23. Functional Block Diagram

OUTPUT CURRENT CAPABILITY

The ADM8845 can drive up to 30 mA of current to each of the six LEDs given an input voltage of 2.6 V to 5.5 V. The LED currents have a maximum current matching of 1% between any two LED currents. An external resistor, R_{SET} , sets the output current, approximated by the following equation:

$$R_{SET} = 120 \times (1.18 \text{ V}/I_{LED})$$

To regulate the LED currents properly, sufficient headroom voltage (compliance) must be present. The compliance refers to the minimum amount of voltage that must be present across the internal current sinks to ensure that the desired current and matching performance can be realized. To ensure that the desired current is obtained, use the following equation to find the minimum input voltage required:

$$V_{OUT} - V_F \geq \text{Compliance}$$

where V_F is the LED forward voltage. For 20 mA/LED, the compliance is 0.20 V typical and 0.30 V maximum (see Table 6).

Table 6. I_{LED} , R_{SET} , and Compliance Table

I_{LED} (mA)	R_{SET} (k Ω)	Typical Compliance (V)
15	9.44	0.17
20	7.08	0.20
30	4.72	0.34

When the ADM8845 charge pump is loaded with 180 mA (six LEDs at 30 mA/LED), the ambient operating temperature is reduced (see Figure 21).

AUTOMATIC GAIN CONTROL

The automatic gain control block controls the operation of the charge pump by selecting the appropriate gain for the charge pump. This maintains sufficient drive for the LED anodes at the highest power efficiency over a 2.6 V to 5.5 V input supply range. The charge pump switching thresholds are described in Table 7.

Table 7. Charge Pump Switching Thresholds

Gain	Threshold (V)
1.5 \times to 2 \times	3.33
2 \times to 1.5 \times	3.36
1 \times to 1.5 \times	4.77
1.5 \times to 1 \times	4.81

CURRENT MATCHING

The 1% maximum current matching performance is defined by the following equations:

$$I_{AVG} = (I_{MAX} + I_{MIN})/2$$

$$\text{Maximum Matching Error} = [(I_{MAX} - I_{AVG})/I_{AVG}] \times 100$$

or

$$\text{Minimum Matching Error} = [(I_{MIN} - I_{AVG})/I_{AVG}] \times 100$$

where:

I_{MAX} is the largest I_{LED} current.

I_{MIN} is the smallest I_{LED} current.

BRIGHTNESS CONTROL WITH A DIGITAL PWM SIGNAL

PWM brightness control provides the widest brightness control method by pulsing the white LEDs on and off using the digital input control pins, CTRL1 and/or CTRL2. PWM brightness control also removes any chromaticity shifts associated with changing the white LED current, because the LEDs operate either at zero current or full current (set by R_{SET}).

The digital PWM signal applied with a frequency of 100 Hz to 200 kHz turns the current control sinks on and off using CTRL1 and/or CTRL2. The average current through the LEDs changes with the PWM signal duty cycle. If the PWM frequency is much less than 100 Hz, flicker could be seen in the LEDs. For the ADM8845, zero duty cycle turns off the LEDs, and a 50% duty cycle results in an average LED current I_{LED} being half the programmed LED current. For example, if R_{SET} is set to program 20 mA/LED, a 50% duty cycle results in an average I_{LED} of 10 mA/LED, I_{LED} being half the programmed LED current.

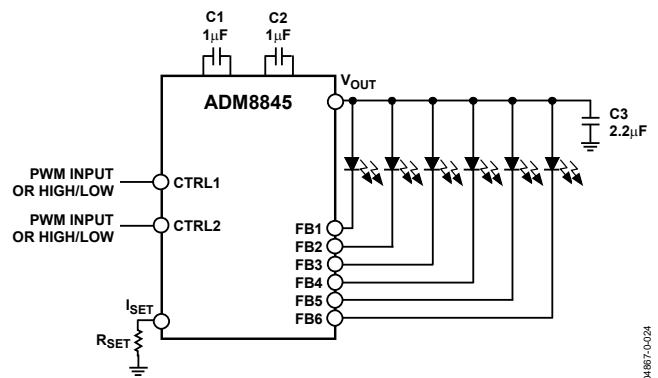

Figure 24. Digital PWM Brightness Control Application Diagram

By applying a digital PWM signal to the digital input control pins, CTRL1 and/or CTRL2 can adjust the brightness of the sub and/or main displays. The six white LEDs of the ADM8845 are organized into two groups: main display, FB1 to FB4, and sub display, FB5 and FB6. For more information, refer to the Theory of Operation section.

The main and sub display brightness of the ADM8845 can be controlled together or separately by applying a digital PWM signal to both CTRL1 and CTRL2 pins. The duty cycle of the applied digital PWM signal determines the brightness of the main and sub displays together. Varying the duty cycle of the applied PWM signal also varies the brightness of the main and sub displays from 0% to 100%.

By holding CTRL1 low and applying a digital PWM signal to CTRL2, the sub display is turned off and the main display is turned on. The brightness of the main display is then determined by the duty cycle of the applied digital PWM signal.

By applying a digital PWM signal to CTRL1 and holding CTRL2 low, the sub display is turned on and the main display is turned off. Then the brightness of the sub display is determined by the duty cycle of the applied digital PWM signal.

By applying a digital PWM signal to CTRL1 and holding CTRL2 high, the sub display is turned on and the main display is turned on. Then the brightness of the sub display is determined by the

duty cycle of the applied digital PWM signal. The brightness of the main display is set to the maximum, which is set by R_{SET} .

By holding CTRL1 high and applying a digital PWM signal to CTRL2, the sub display is turned on and the main display is turned on. Then the brightness of the main display is determined by the duty cycle of the applied digital PWM signal. The brightness of the sub display is set to the maximum, which is set by R_{SET} .

When CTRL1 and CTRL2 go low, the LED current control sinks shutdown. Shutdown of the charge pump is delayed by 15 ms. This timeout period (t_{CP}) allows the ADM8845 to determine if a digital PWM signal is present on CTRL1 and CTRL2 or if the user has selected a full chip shutdown (see Figure 25).

If digital PWM brightness control of the LEDs is not required, a constant logic level 1 (V_{CC}) or 0 (GND) must be applied.

The six white LEDs in the ADM8845 are arranged in two groups, sub and main. It is possible to configure the six LEDs as in Table 8. For more information, also refer to Figure 25.

Table 8. Digital Inputs Truth Table

CTRL1	CTRL2	LED Operation
0	0	Sub display off/main display off (full shutdown) ^{1, 2}
0	1	Sub display off/main display on ^{1, 3}
1	0	Sub display on/main display off ^{4, 2}
1	1	Sub display on/main display on (full on) ^{4, 3}
0	PWM	Sub display off/digital PWM brightness control on main display ^{1, 5}
PWM	0	Digital PWM brightness control on sub display/main display off ^{5, 2}
1	PWM	Sub display on/ digital PWM brightness control on main display ^{4, 5}
PWM	1	Digital PWM brightness control on sub display/main display on ⁵
PWM	PWM	Digital PWM brightness control on sub and main display ⁵

¹ Sub display off means the sub display LEDs only is off. CTRL1 = 0 means a constant logic level (GND) is applied to CTRL1.

² Main display off means the main display only is off. CTRL2 = 0 means a constant logic level (GND) is applied to CTRL2.

³ Main display on means the display is on with the maximum brightness set by the R_{SET} resistor. CTRL2 = 1 means a constant logic level (V_{CC}) is applied to CTRL2.

⁴ Sub display on means the display is on with the maximum brightness set by the R_{SET} resistor. CTRL1 = 1 means a constant logic level (V_{CC}) is applied to CTRL1.

⁵ PWM means a digital PWM signal is applied to the CTRL1 and/or the CTRL2 pin with a frequency from 100 Hz to 200 kHz.

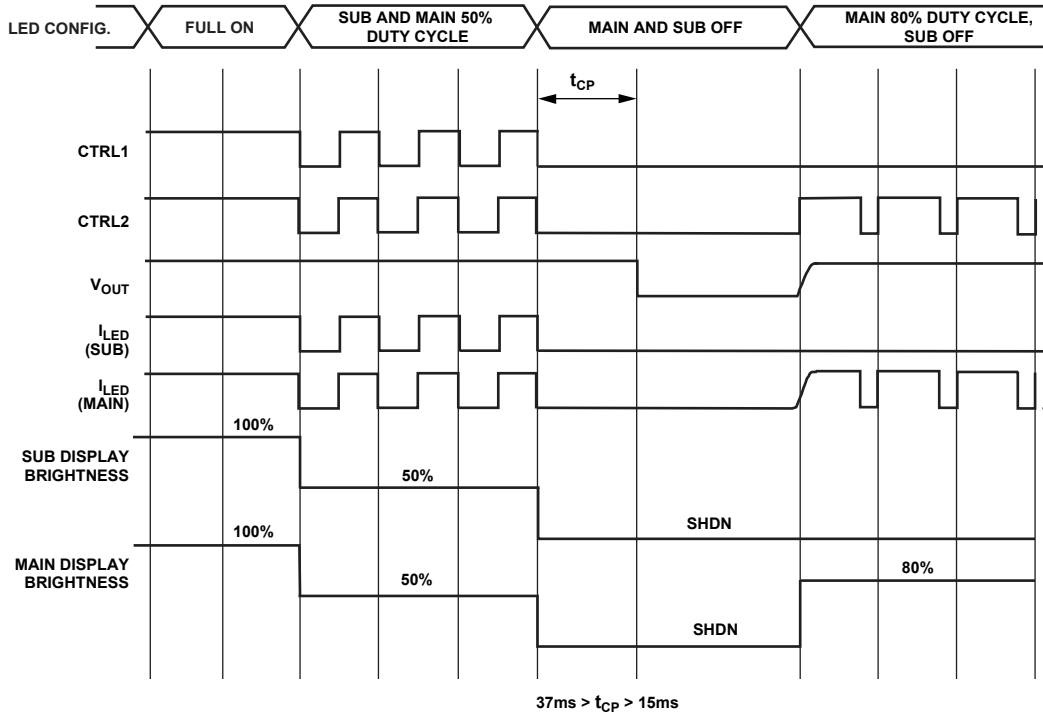

Figure 25. Application Timing

LED BRIGHTNESS CONTROL USING A PWM SIGNAL APPLIED TO V_{PWM}

Adding two external resistors and a capacitor, as shown in Figure 26, can also be used to control PWM brightness. This PWM brightness control method can be used instead of CTRL1 and/or CTRL2 digital PWM brightness control. With this configuration, the CTRL1 and CTRL2 digital logic pins can be used to control shutdown of the white LEDs, while V_{PWM} can be used to control the brightness of all the white LEDs by applying a high frequency PWM signal (amplitude 0 V to 2.5 V) to drive an R-C-R filter on the I_{SET} pin of the ADM8845. A 0% PWM duty cycle corresponds to 20 mA/LED, while a 100% PWM duty cycle corresponds to a 0 mA/LED. At PWM frequencies above 5 kHz, C5 may be reduced (see Figure 26). To have 20 mA flowing in each LED, the amplitude of the PWM signal must be 0 V and 2.5 V only.

$$I_{LED} = \frac{I_{SET} - \text{Voltage}}{R_{SET} \times 2R} \times 120 \times \frac{(1 - \text{Duty Cycle})}{100}$$

$$\frac{I_{LED}}{R_{SET} + 2R}$$

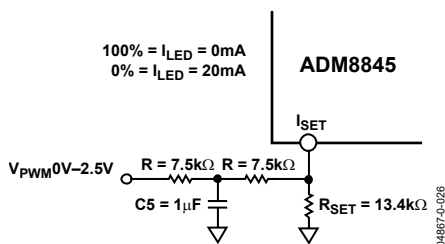

Figure 26. PWM Brightness Control Using Filtered PWM Signal

LED BRIGHTNESS CONTROL USING A DC VOLTAGE APPLIED TO V_{BRIGHT}

By adding one resistor, as in Figure 22, this configuration can control the brightness of the white LEDs using a dc voltage applied to the V_{BRIGHT} node. Figure 27 shows an application example of LED brightness control using a dc voltage with an amplitude of 0 V to 2.5 V, applied to V_{BRIGHT}.

The equation for I_{LED} is

$$I_{SET} = [(1/R_{SET} + 1/R)(V_{SET})] - [(1/R)(V_{BRIGHT})]$$

$$I_{LED} = 120 \times I_{SET}$$

where:

R = 15 kΩ.

V_{SET} the voltage at I_{SET} pin (1.18 V).

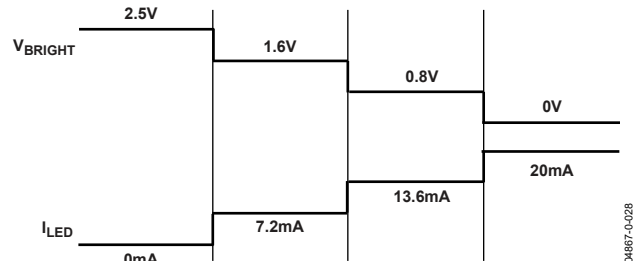

Figure 27. PWM Brightness Control Application Diagram Using a DC Voltage Applied to V_{BRIGHT}

APPLICATIONS INFORMATION

LAYOUT CONSIDERATIONS AND NOISE

Because of the switching behavior of the ADM8845, PCB trace layout is an important consideration. To ensure optimum performance, a ground plane should be used, and all capacitors (C1, C2, C3, C4) must be located with minimal track lengths to the pins of the ADM8845.

WHITE LED SHORTING

If an LED is shorted, the ADM8845 continues to drive the remaining LEDs with I_{LED} per LED ($I_{LED} = I_{SET} \times 120 \text{ mA}$). This is because the ADM8845 uses six internal current sinks to produce the LED current. If an LED is shorted, the ADM8845 continues to sink ($I_{SET} \times 120 \text{ mA}$) as programmed by R_{SET} through the shorted LED.

DRIVING FEWER THAN SIX LEDs

The ADM8845 can be operated with fewer than six LEDs in parallel by simply leaving the unused FBx pins floating or connected to GND. For example, Figure 28 shows five LEDs being powered by the ADM8845, and Figure 29 shows three main LEDs and one sub LED.

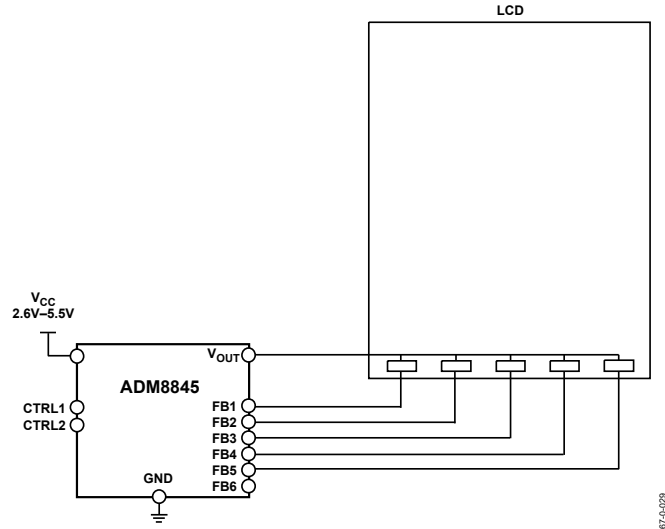

Figure 28. Driving Five White LEDs

04887-Q-029

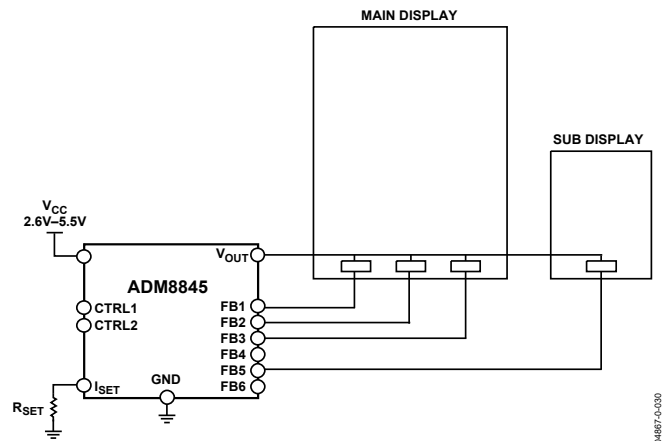

Figure 29. Driving Three Main LEDs and One Sub LED

04887-Q-030

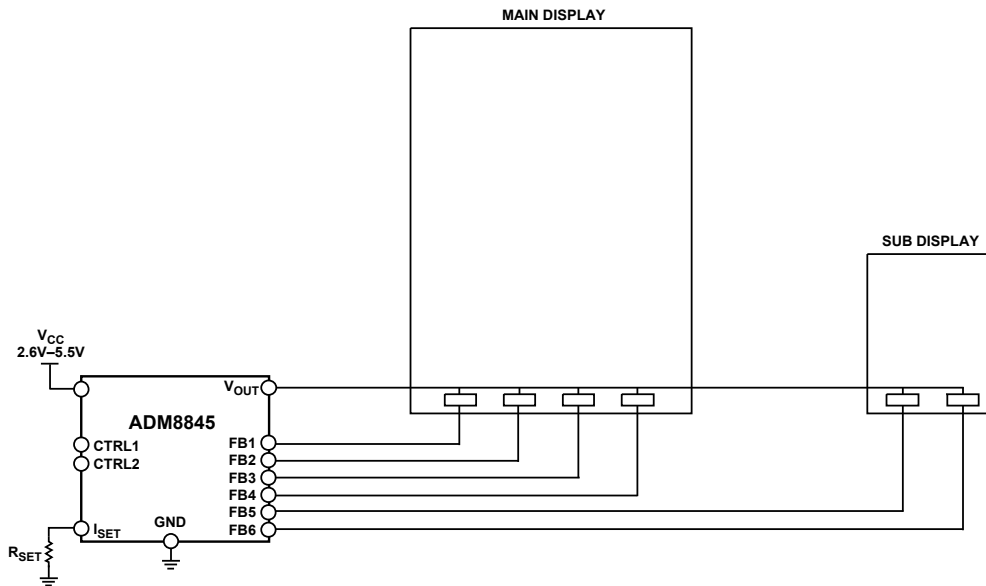

Figure 30. Typical Application Diagram

04887-Q-002

DRIVING FLASH LEDS

The ADM8845 can be operated with any two FBx pins used in parallel to double the combined LED current supplied by the ADM8845. For example, if three flash LEDs need to be driven with 60 mA/LED, the ADM8845 can be configured as in Figure 31 (see also Figure 21).

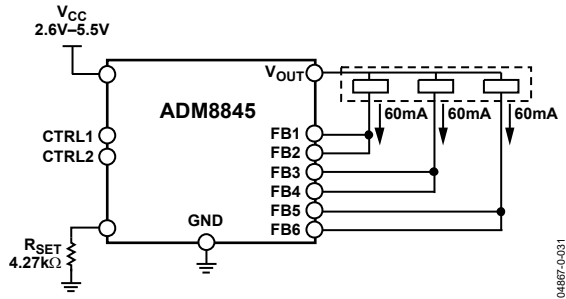

Figure 31. Driving Three Flash LEDs

DRIVING CAMERA LIGHT, MAIN, AND SUB LEDS

The ADM8845 can be configured to power a camera light that is composed of four white LEDs in parallel, along with the main and sub display bundled into one package. FB1 to FB4 now power the camera light, and FB5 and FB6 power the main display. The sub display LED is powered from the ADM8845 by using an external current mirror to control the current flowing through the sub white LED (see Figure 32). All white LEDs have 15 mA/LED. Total load on the ADM8845 charge pump is therefore 105 mA, and the maximum load on the ADM8845 charge pump is 180 mA (see Figure 21).

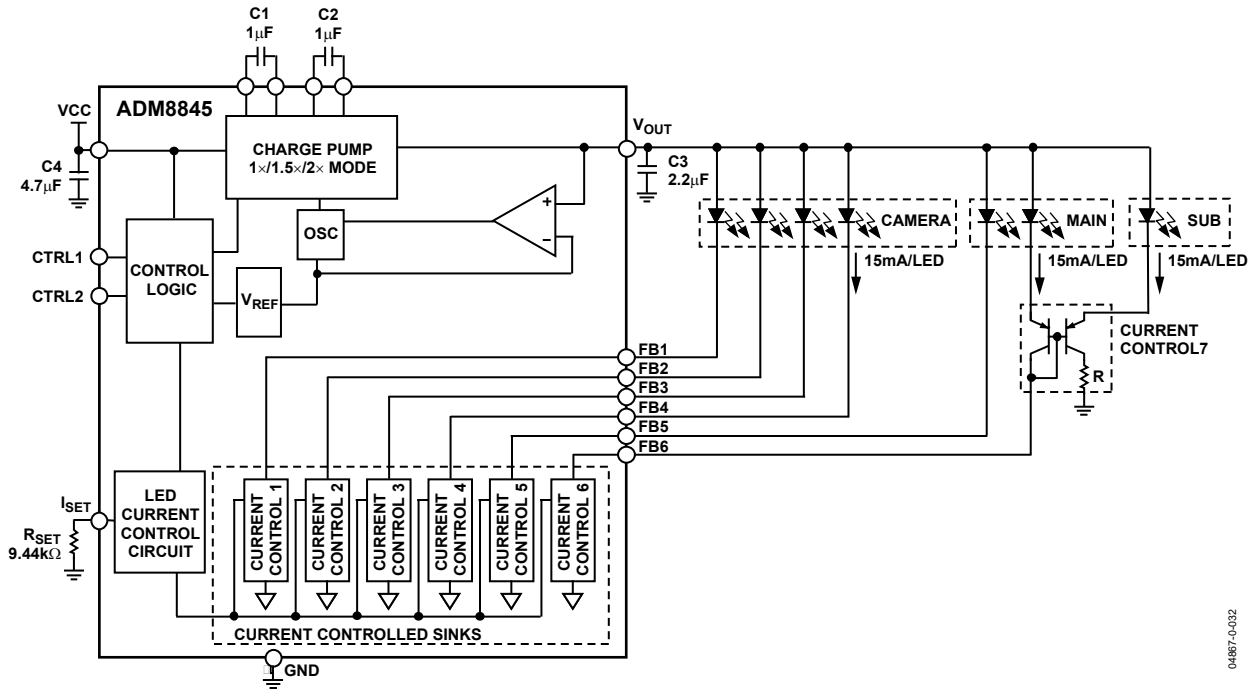

Figure 32. Driving Camera Light, Two Main LEDs, and One Sub LED

DRIVING FOUR BACKLIGHT WHITE LEDs AND FLASH LEDs

The ADM8845 can be configured to power four backlight white LEDs and a camera flash, bundled into one package. FB1 to FB4 power the backlight light, FB5 and FB6 power two of the flash LEDs, while the third is powered by an external current mirror to control the current flowing through the third flash LED (see Figure 33). All the backlight white LEDs have 15 mA/LED, and the flash current is 20 mA/LED. The total load on the ADM8845 charge pump is 120 mA; the maximum load on the ADM8845 charge pump is 180 mA (see Figure 21).

CTRL1 controls the flash on/off, and CTRL2 controls the backlight on/off and brightness control. Because the R_{SET} resistor sets the current that each of the six current control blocks can sink, a PWM signal is used to change the current in the backlight from 20 mA to 5 mA/LED. The CTRL2 duty cycle is 15/20 to give 15 mA/backlight LED.

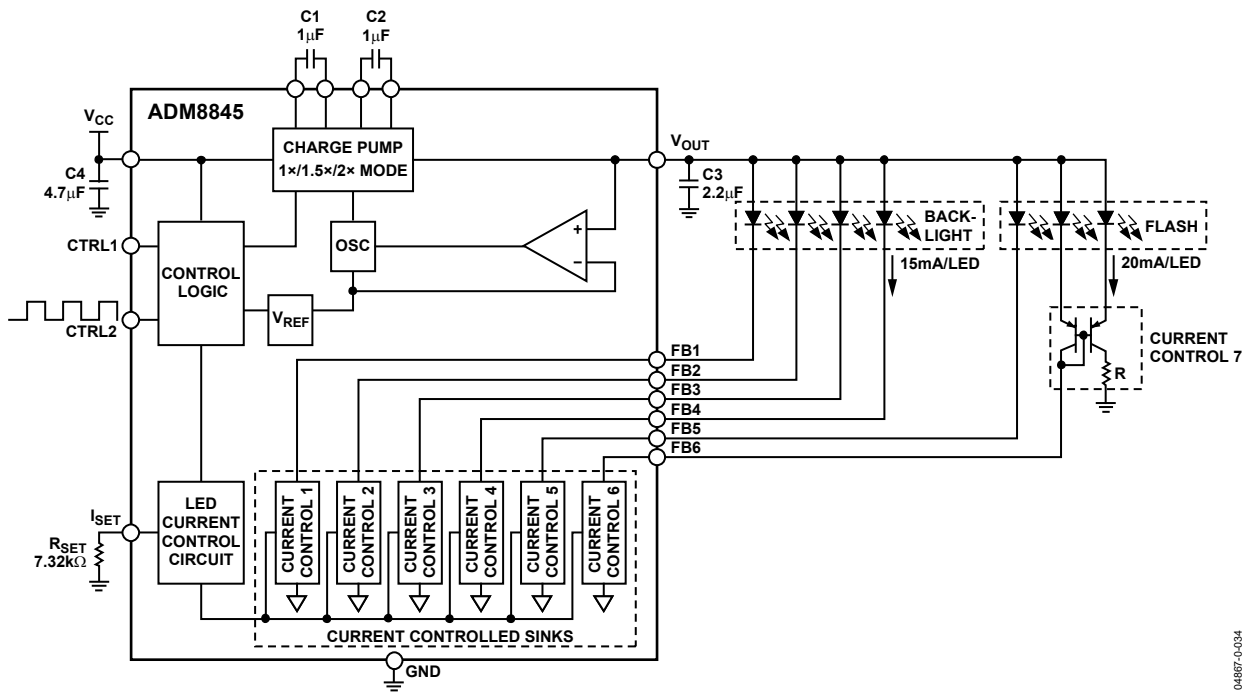

Figure 33. Driving Four Backlight LEDs and Flash LED

04867-0-034

POWER EFFICIENCY

The ADM8845 power efficiency (η) equations are the following:

$$\eta = P_{OUT}/P_{IN}$$

$$P_{IN} = ((V_{CC} \times I_{LOAD} \times Gain) + (I_Q \times V_{CC}))$$

$$P_{OUT} = 6 \times (V_F \times I_{LED})$$

where:

Gain is equal to the charge pump mode (1×, 1.5×, 2×).

I_Q is the quiescent current of the ADM8845, 2.6 mA.

V_F is the LED forward voltage.

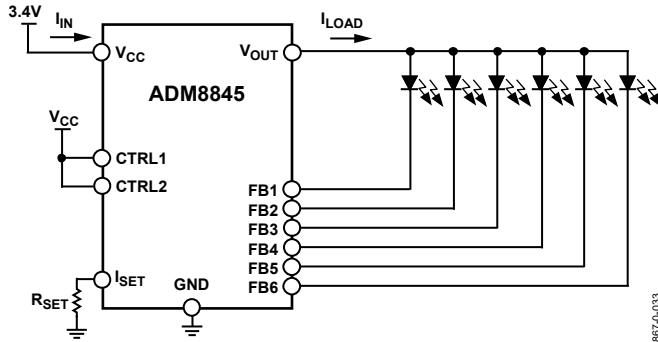

Figure 34. Charge Pump Power Efficiency Diagram

Example 1 and Example 2 show calculations of the ADM8845 power efficiency. See Figure 34 as well.

Example 1

The ADM8845 driving six white LEDs with a 20 mA/LED at $V_{CC} = 3.4$ V (1.5× mode) and LED $V_F = 4.5$ V.

$$P_{IN} = ((V_{CC} \times I_{LOAD} \times Gain) + (V_{CC} \times I_Q))$$

$$P_{IN} = ((3.4 \times 120 \text{ mA} \times 1.5) + (3.4 \times 2.6 \text{ mA}))$$

$$P_{IN} = ((0.612) + (0.00884))$$

$$P_{IN} = 0.62084$$

$$P_{OUT} = 6 \times (V_F \times I_{LED})$$

$$P_{OUT} = 6 \times (4.5 \text{ V} \times 20 \text{ mA})$$

$$P_{OUT} = 0.54$$

$$\eta = P_{OUT}/P_{IN}$$

$$\eta = 0.54/0.62084$$

$$\eta = 87\%$$

Example 2

The ADM8845 driving six white LEDs with a 20 mA/LED at $V_{CC} = 3.4$ (1.5× mode) and LED $V_F = 3.6$ V.

$$P_{IN} = ((V_{CC} \times I_{LOAD} \times Gain) + (V_{CC} \times I_Q))$$

$$P_{IN} = ((3.4 \times 120 \text{ mA} \times 1.5) + (3.4 \times 2.6 \text{ mA}))$$

$$P_{IN} = ((0.612) + (0.00884))$$

$$P_{IN} = 0.62084$$

$$P_{OUT} = 6 \times (V_F \times I_{LED})$$

$$P_{OUT} = 6 \times (3.6 \text{ V} \times 20 \text{ mA})$$

$$P_{OUT} = 0.432$$

$$\eta = P_{OUT}/P_{IN}$$

$$\eta = 0.432/0.62084$$

$$\eta = 70\%$$

OUTLINE DIMENSIONS

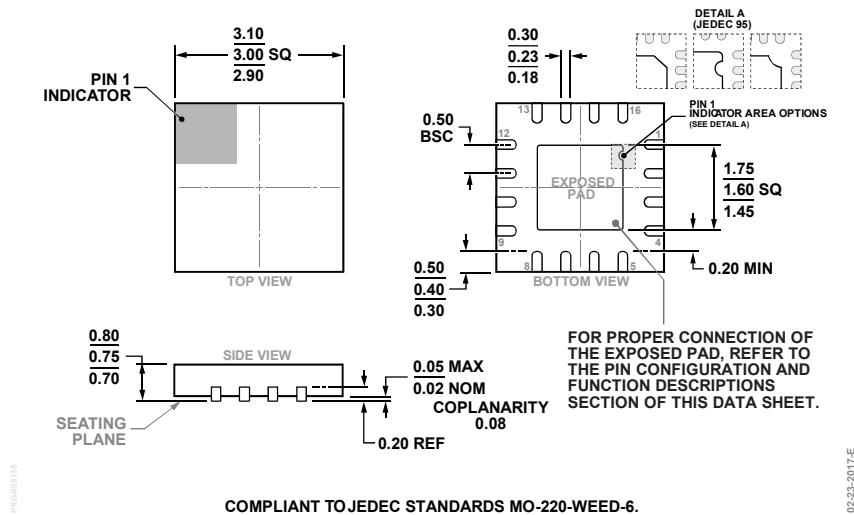

COMPLIANT TO JEDEC STANDARDS MO-220-WEED-6.
 Figure 35. 16-Lead Lead Frame Chip Scale Package [LFCSP]
 3 mm × 3 mm Body and 0.75 mm Package Height
 (CP-16-22)
 Dimensions shown in millimeters

ORDERING GUIDE

Model ¹	Temperature Range	Package Description	Package Option	Marking Code
ADM8845ACPZ-REEL7	-40°C to +85°C	16-Lead Lead Frame Chip Scale Package [LFCSP]	CP-16-22	M5G
ADM8845EB-EVALZ		Evaluation Board		

¹ Z = RoHS Compliant Part.