

2 Channels Electronic Volume

■GENERAL DESCRIPTION

The NJU72341 is a 2 channels I²C electronic volume IC with external mute controls.

The NJU72341 has many characteristics that are useful in audio application, such as low noise, low distortion, and wide operating voltage range.

All functions are controlled by I²C BUS interface.

■PACKAGE OUTLINE

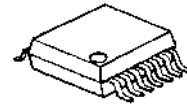

SSOP14

■FEATURES

- Operating Voltage V₊=4.5V ~ 14.5V
- Input Gain 0dB/+3dB/+6dB/+9dB
- Volume 0~-95dB/Mute ,1dBstep
- Low Distortion 0.002% typ.
- Low Noise 2.0μVrms typ.
- External Mute
- Zero Cross Detection
- I²C BUS Control
- CMOS Technology
- Small Package SSOP14

■BLOCK DIAGRAM

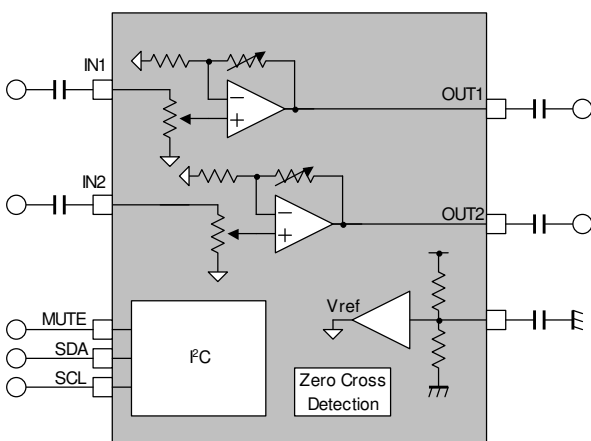

■ PIN CONFIGURATION

No.	Symbol	Function
1	NC	-
2	NC	-
3	IN1	Input Terminal 1
4	IN2	Input Terminal 2
5	MUTE	Mute Terminal
6	SDA	I ² C Data Input Terminal /Acknowledge Output
7	SCL	I ² C Clock Terminal
8	V+	Power Supply Terminal
9	VREF	Reference Voltage Terminal
10	GND	Ground Terminal
11	OUT2	Output Terminal 2
12	OUT1	Output Terminal 1
13	NC	-
14	NC	-

■ABSOLUTE MAXIMUM RATING (Ta=25°C)

PARAMETER	SYMBOL	RATING	UNIT
Supply Voltage	V ₊	+15	V
Power Dissipation	P _D	450 (Note1)	mW
Maximum Input Voltage	V _{IMAX}	0 ~ V ₊ (Note2)	V
Operating Temperature Range	Topr	-40 ~ +85	°C
Storage Temperature Range	Tstg	-40 ~ +125	°C

(Note1) EIA/JEDEC STANDARD Test board (76.2x114.3x1.6mm, 2layer, FR-4) mounting

(Note2) Don't put Input Voltage more than Power Supply Voltage.

■ELECTRICAL CHARACTERISTICS

(Ta=25°C, V⁺=9V, R_L=47kΩ, V_{IN}=1.5Vrms, f=1kHz, all controls flat unless otherwise specified)

PARAMETER	SYMBOL	TEST CONDITION	MIN.	TYP.	MAX.	UNIT
Operating Voltage	V ⁺		4.5	9	14.5	V
Supply Current	I _{DD}	No signal	-	5.5	9	mA
Reference Voltage	V _{REF}	No signal	4.0	4.5	5.0	V
Maximum Input Voltage	V _{INS}	Main Volume=-6dB, THD=1%	-	3.6	-	Vrms
Maximum Output Voltage	V _{OM}	THD=1%	2.2	2.6	-	Vrms
Voltage Gain 1	G _{V1}	Input Gain=+6dB, V _{IN} =100mVrms	4	6	8	dB
Voltage Gain 2	G _{V2}		-1.5	0	1.5	dB
Voltage Gain 3	G _{V3}	Main Volume=Mute, BW=400Hz-30kHz	-	-106	-95	dB
Channel Balance	G _{CB}	Main Volume=0dB	-1	0	1	dB
Total Harmonic Distortion	THD	Vo=1.5Vrms, BW=400Hz~30kHz	-	0.002	0.01	%
Output Noise Voltage	V _{NO}	Main Volume=0dB	-	2.0	7.0	μVrms
Channel Separation	CS	R _g =0	-	-110	-90	dB

MUTE TERMINAL CONTROL CHARACTERISTICS (Ta=25°C, all controls flat unless otherwise specified)

PARAMETER	SYMBOL	TEST CONDITION	MIN.	TYP.	MAX.	UNIT
Low Level Input Voltage	V _{IL}		0	-	0.6	V
High Level Input Voltage	V _{IH}		2.0	-	V ⁺	V

■CONTROL TERMINAL EXPLANATION -Mute Terminal-

(Ta=25°C, V⁺=9V, R_L=47kΩ, V_{IN}=1.5Vrms, f=1kHz, all controls flat unless otherwise specified)

MODE	STATUS	TEST CONDITION
Mute ON	H	Mute is Active
Mute OFF	L	Mute is NOT Active

■ TERMINAL DESCRIPTION

Terminal	SYMBOL	FUNCTION	EQUIVALENT CIRCUIT	VOLTAGE
3 4	IN1 IN2	AC Input		$V^+/2$
5	MUTE	MUTE Control		0V
6	SDA	I ² C Data Input / Acknowledge Output		-
7	SCL	I ² C Clock Input		-

■ TERMINAL DESCRIPTION

Terminal	SYMBOL	FUNCTION	EQUIVALENT CIRCUIT	VOLTAGE
8	V+	Supply Voltage		V+
9	VREF	Reference Voltage		$V^+/2$
11 12	OUT2 OUT1	AC Output		$V^+/2$

TEST CIRCUIT

◆ I_{DD} / V_{REF}

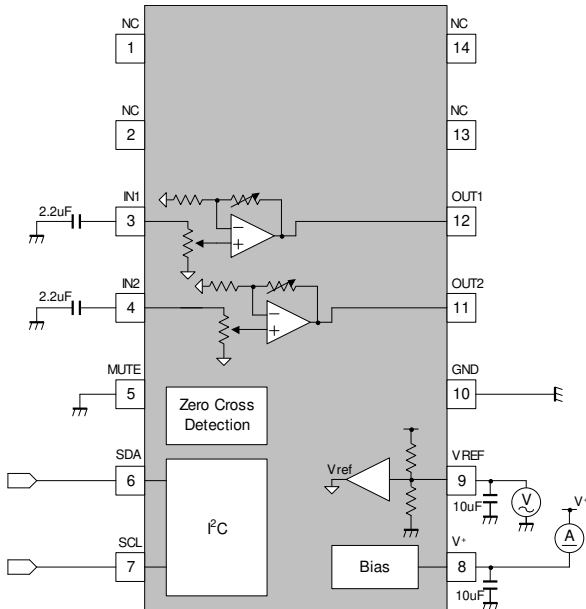

◆ $V_{INS} / V_{OM} / G_{V1} / G_{V2} / G_{V3} / G_{CB} / THD$

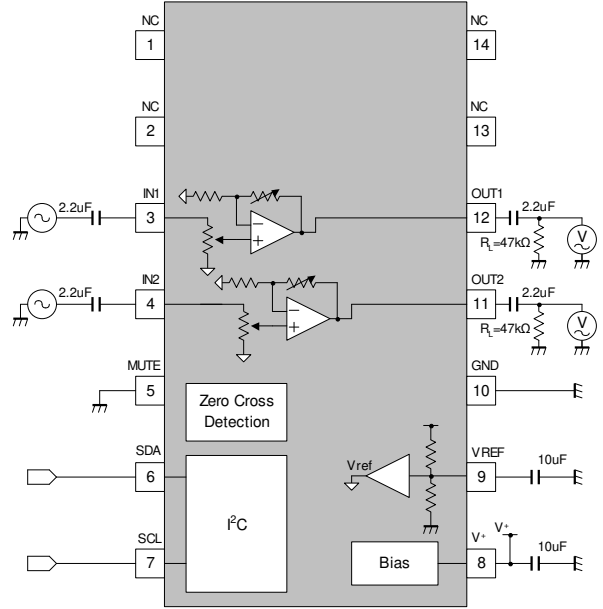

◆ V_{NO}

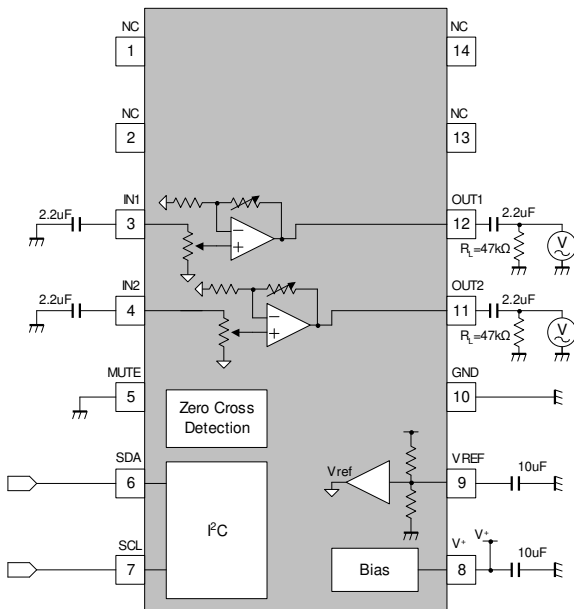

◆ CS

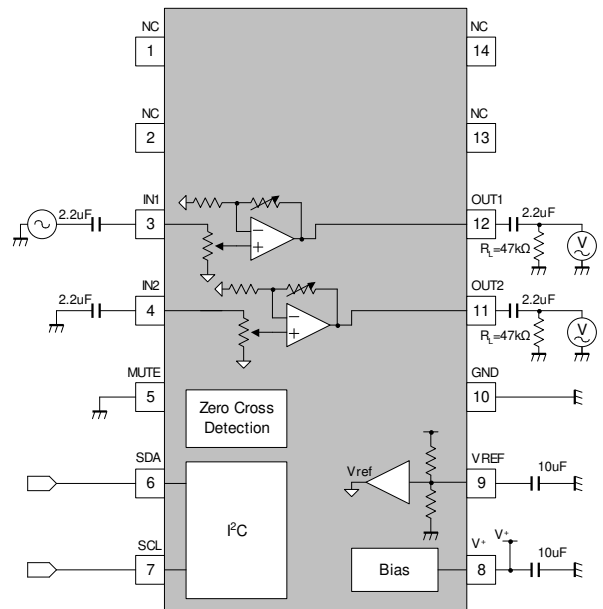

APPLICATION CIRCUIT

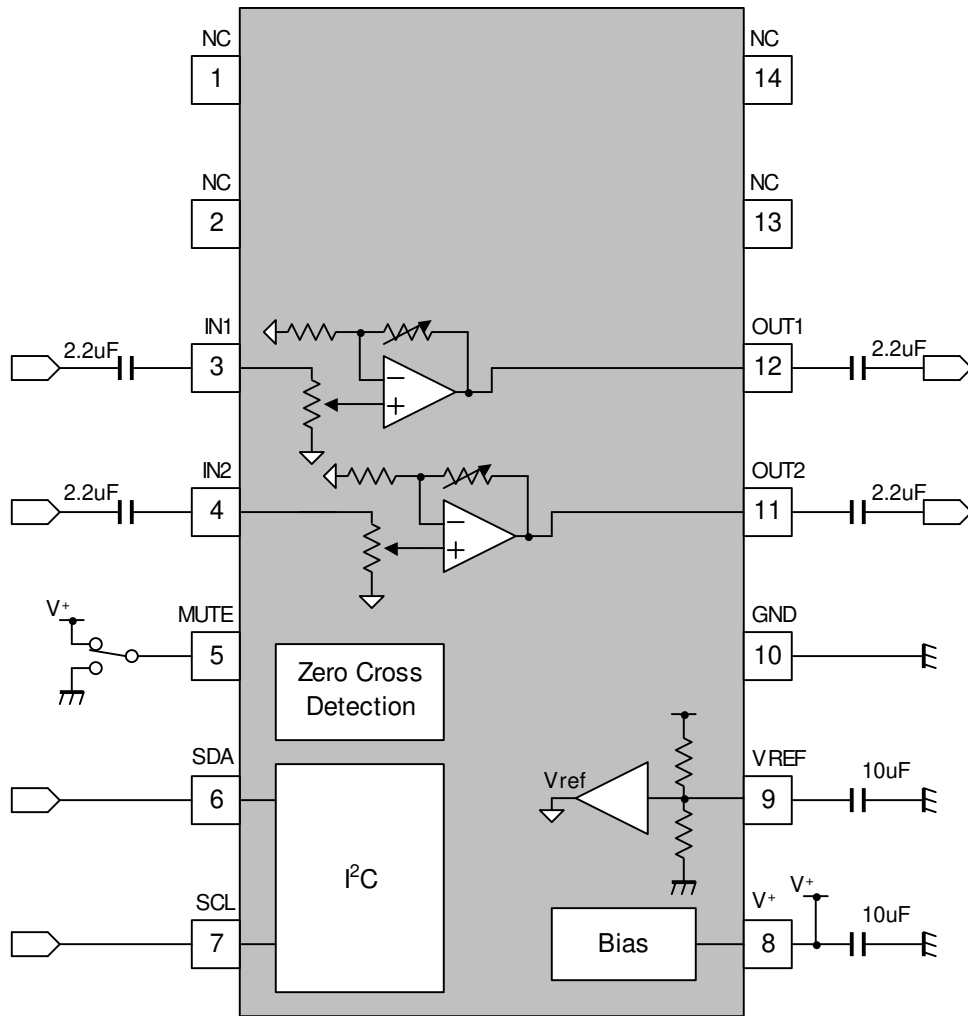

■TIMING ON THE I²C BUS (SDA, SCL)

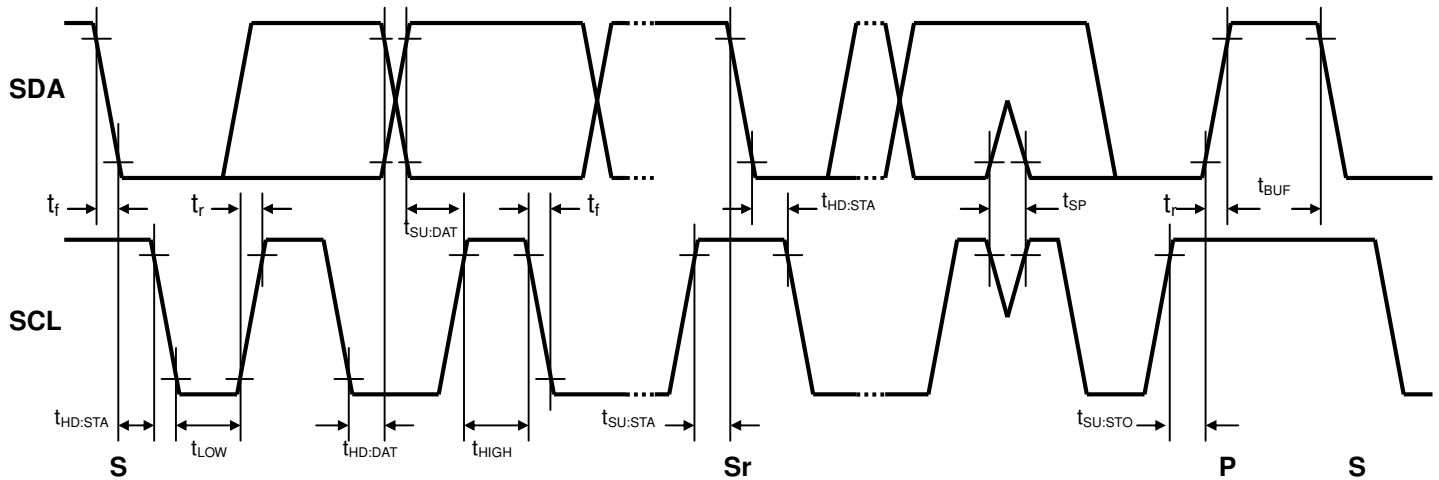

■CHARACTERISTICS OF I/O STAGES FOR I2C BUS (SDA,SCL)

I²C BUS Load Conditions

STANDARD MODE : Pull up resistance 4kΩ (Connected to +5V), Load capacitance 200pF (Connected to GND)

FAST MODE : Pull up resistance 4kΩ (Connected to +5V), Load capacitance 50pF (Connected to GND)

PARAMETER	SYMBOL	Standard mode			Fast mode			UNIT
		MIN.	TYP.	MAX.	MIN.	TYP.	MAX.	
Low Level Input Voltage	V _{IL}	0.0	-	1.5	0.0	-	1.5	V
High Level Input Voltage	V _{IH}	2.7	-	5.5	2.7	-	5.5	V
Low Level output voltage (3mA at SDA pin)	V _{OL}	0	-	0.4	0	-	0.4	V
Input current each I/O pin with an input voltage between 0.1V _{DD} and 0.9V _{DDmax}	I _i	-10	-	10	-10	-	10	μA

■CHARACTERISTICS OF BUS LINES (SDA,SCL) FOR I²C-BUS DEVICES

PARAMETER	SYMBOL	Standard mode			Fast mode			UNIT
		MIN.	TYP.	MAX.	MIN.	TYP.	MAX.	
SCL clock frequency	f _{SCL}	-	-	100	-	-	400	kHz
Hold time (repeated) START condition.	t _{HD:STA}	4.0	-	-	0.6	-	-	μs
Low period of the SCL clock	t _{LOW}	4.7	-	-	1.3	-	-	μs
High period of the SCL clock	t _{HIGH}	4.0	-	-	0.6	-	-	μs
Set-up time for a repeated START condition	t _{SU:STA}	4.7	-	-	0.6	-	-	μs
Data hold time	t _{HD:DAT}	0	-	-	0	-	-	μs
Data set-up time	t _{SU:DAT}	250	-	-	100	-	-	ns
Rise time of both SDA and SCL signals	t _r	-	-	1000	-	-	300	ns
Fall time of both SDA and SCL signals	t _f	-	-	300	-	-	300	ns
Set-up time for STOP condition	t _{SU:STO}	4.0	-	-	0.6	-	-	μs
Bus free time between a STOP and START condition	t _{BUF}	4.7	-	-	1.3	-	-	μs
Capacitive load for each bus line	C _b	-	-	400	-	-	400	pF
Noise margin at the Low Level	V _{nL}	0.5	-	-	0.5	-	-	V
Noise margin at the High Level	V _{nH}	1	-	-	1	-	-	V

C_b ; total capacitance of one bus line in pF.

■ RECOMMENDED POWER-UP SEQUENCE

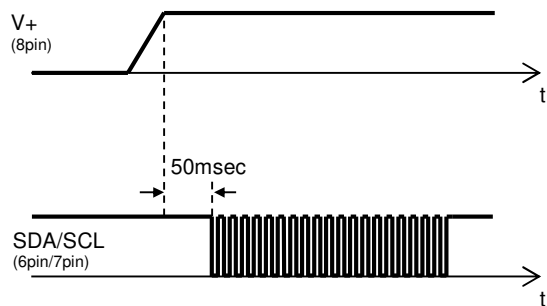

■ DEFINITION OF I²C REGISTER

Note) Please don't send except specified data for avoiding an incorrect operation.

◆ I²C BUS FORMAT

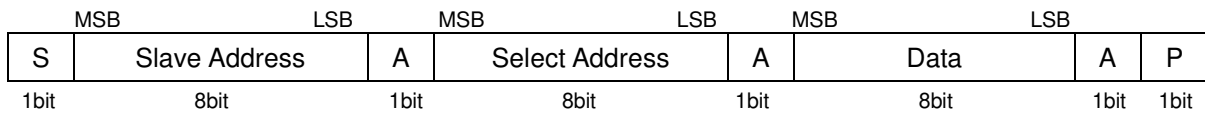

S: Starting Term
A: Acknowledge Bit
P: Ending Term

◆ SLAVE ADDRESS

Slave Address								Hex
MSB				LSB				-
1	0	0	0	1	0	0	0	88(h)

◆ CONTROL REGISTER TABLE

The select address sets each function
(Volume A, Volume 1B, Volume 2B).
The auto increment function cycles the select address as follows.
00H→01H→02H→00H

<Write Mode>

Select Address	BIT							
	D7	D6	D5	D4	D3	D2	D1	D0
00H	*	*	*	*	VOLUME 2A		VOLUME 1A	
01H	ZERO 1	VOLUME 1B						
02H	ZERO 2	VOLUME 2B						

*: Don't Care

◆ CONTROL REGISTER DEFAULT VALUE

Control register default value is all "0".

Select Address	BIT							
	D7	D6	D5	D4	D3	D2	D1	D0
00H	0	0	0	0	0	0	0	0
01H	0	0	0	0	0	0	0	0
02H	0	0	0	0	0	0	0	0

Note.) This product starts up by MUTE setting in power "ON". Use it after removing MUTE of each setting.
If any audio signal is inputted in input signal terminal before power "ON", it may cause initial condition abnormality.
In conditions of use such as the above, it prevents that abnormality by setting MUTE before power "OFF"

■INSTRUCTION CODE

a) VOLUME A SETTING

Select Address	BIT							
	D7	D6	D5	D4	D3	D2	D1	D0
00H	*	*	*	*	VOLUME 2A		VOLUME 1A	

•VOLUME1A/2A: 0 to +9dB (3dB/Step)

b) VOLUME 1B/2B

Select Address	BIT							
	D7	D6	D5	D4	D3	D2	D1	D0
01H	ZERO 1	VOLUME 1B						
02H	ZERO 2	VOLUME 2B						

•ZERO 1/2: Ch1/Ch2 Zero Cross Detection ON/OFF setting

“0”: OFF

“1”: ON

•VOLUME1B/2B: Volume 1B/2B setting 0 to -95 dB (1dB/Step) / Mute

■VOLUME A (Select Address : 00H)

		VOLUME A	
		Ch 1	Ch 2
Gain(dB)	Ch 1	D1	D0
	Ch 2	D3	D2
	0*	0	0
	+3	0	1
+6	1	0	
+9	1	1	

*: Default Value

■ZERO CROSS DETECTION (Select Address : 01H/02H)

		ZERO
		D7
ZERO CROSS DETECTION	Ch 1	D7
	Ch 2	D7
OFF*		0
ON		1

*: Default Value

■ VOLUME B (Select Address : 01H, 02H)

		VOLUME B						
		D6	D5	D4	D3	D2	D1	D0
Gain(dB)	Ch 1	D6	D5	D4	D3	D2	D1	D0
	Ch 2	D6	D5	D4	D3	D2	D1	D0
Mute		1	1	1	1	1	1	1
...		...						
Mute		1	1	1	1	0	0	0
0		1	1	1	0	1	1	1
-1		1	1	1	0	1	1	0
-2		1	1	1	0	1	0	1
-3		1	1	1	0	1	0	0
-4		1	1	1	0	0	1	1
-5		1	1	1	0	0	1	0
-6		1	1	1	0	0	0	1
...		...						
-90		0	0	1	1	1	0	1
-91		0	0	1	1	1	0	0
-92		0	0	1	1	0	1	1
-93		0	0	1	1	0	1	0
-94		0	0	1	1	0	0	1
-95		0	0	1	1	0	0	0
Mute		0	0	1	0	1	1	1
...		...						
Mute*		0	0	0	0	0	0	0

*: Default Value

TYPICAL CHARACTERISTICS

Operating Current vs Supply Voltage
 V_{in} =no signal, R_L =No Load

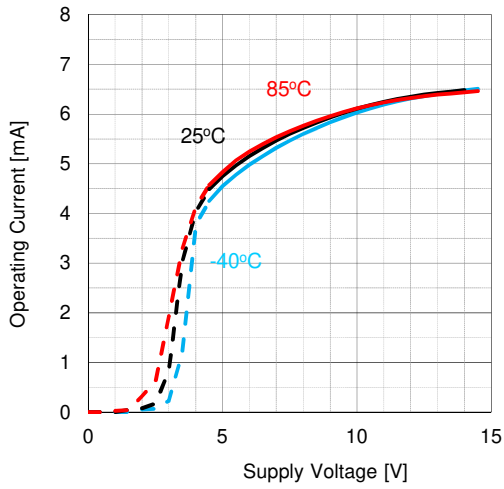

Reference Voltage vs Supply Voltage
 V_{in} =no signal, R_L =No Load

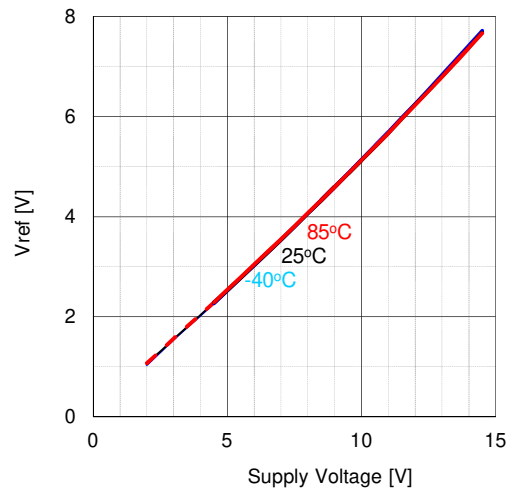

Volume Gain Output vs Volume Setting
 V^+ =9V, T_a =25°C, f =1kHz, Bandpass

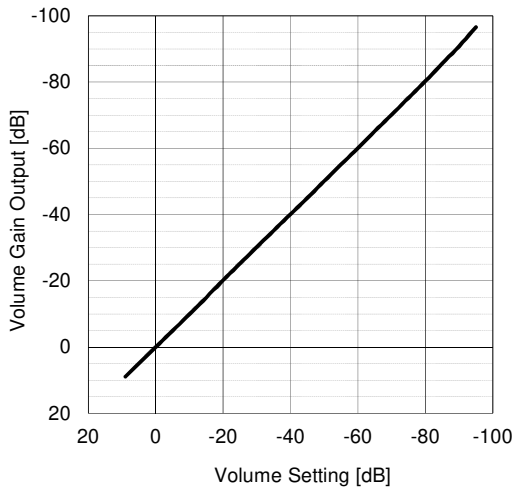

Voltage Gain Output vs Frequency
 V^+ =9V, T_a =25°C, V_{in} =1.5Vrms, Bandpass

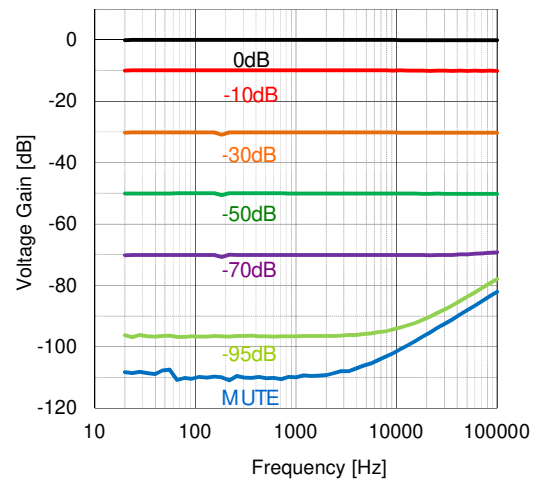

Voltage Gain Output vs Frequency
 V^+ =9V, T_a =25°C, V_{in} =0.1Vrms, Bandpass

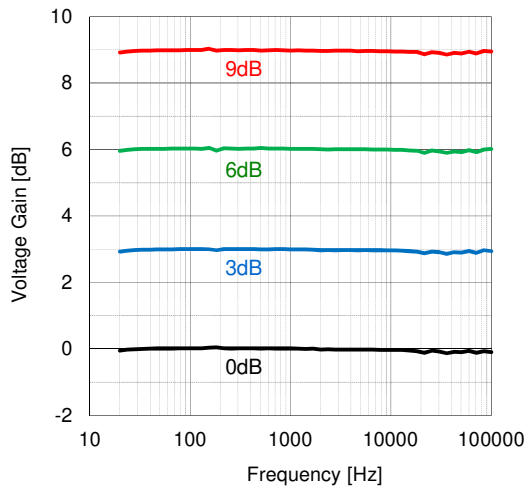

THD+N vs V_{in} -Volume
 V^+ =9V, T_a =25°C, f =1kHz, BW=400Hz-30kHz

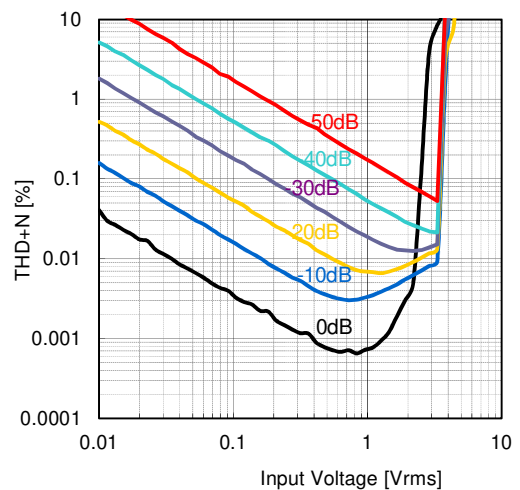

TYPICAL CHARACTERISTICS

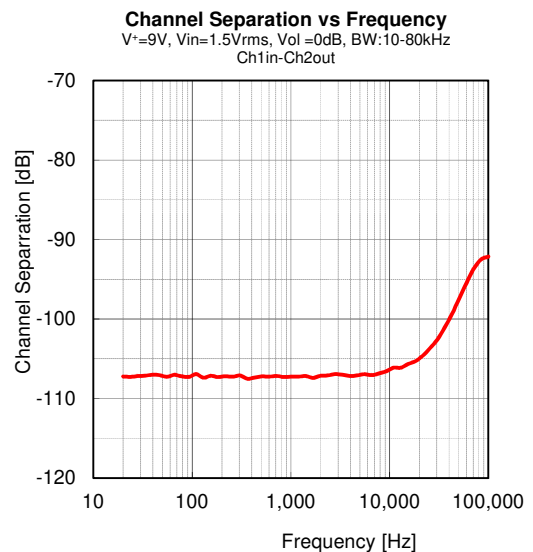
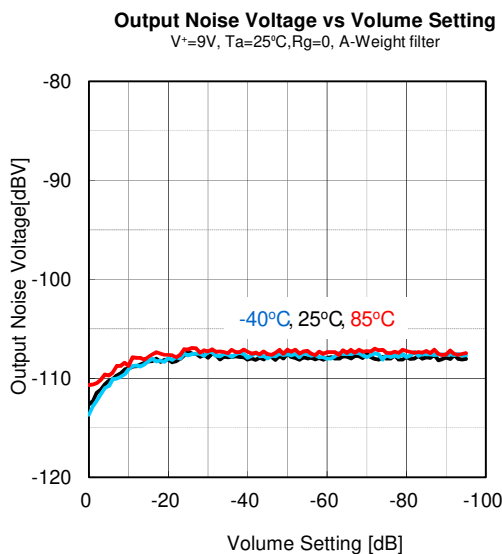
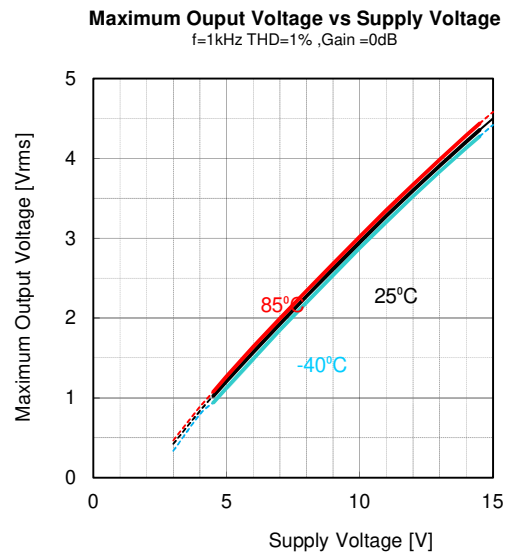
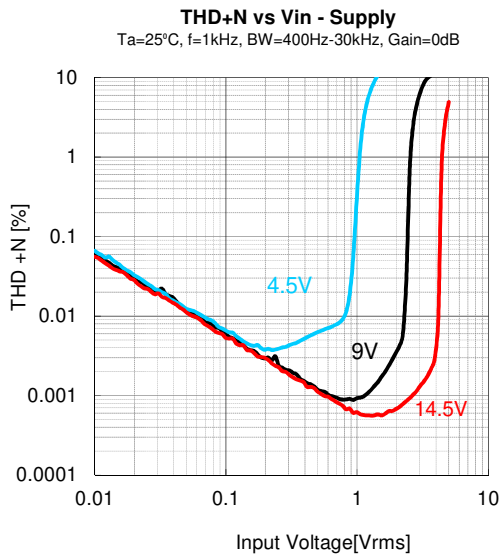
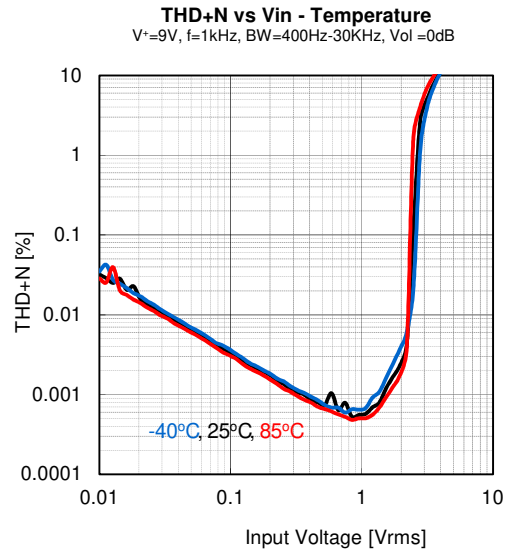
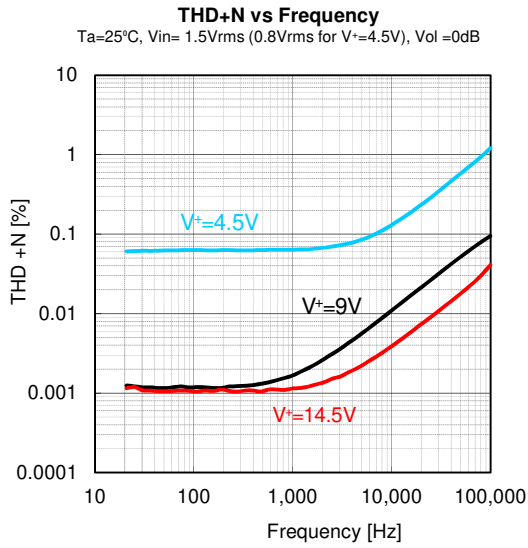

■ TYPICAL CHARACTERISTICS

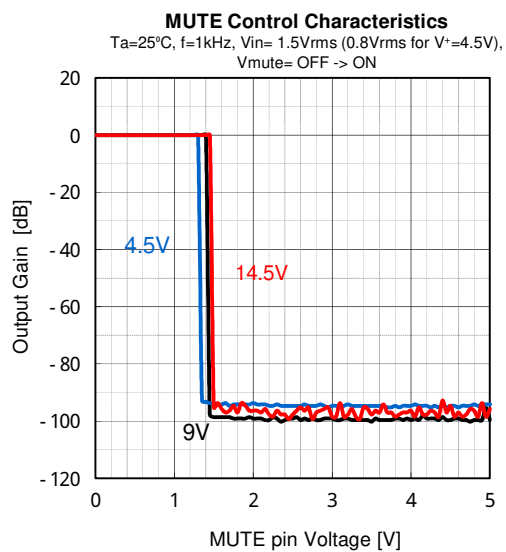

[CAUTION]

The specifications on this databook are only given for information, without any guarantee as regards either mistakes or omissions. The application circuits in this databook are described only to show representative usages of the product and not intended for the guarantee or permission of any right including the industrial rights.