

# Modular Jack Connector for High-Speed Transmission

## TM24R Series

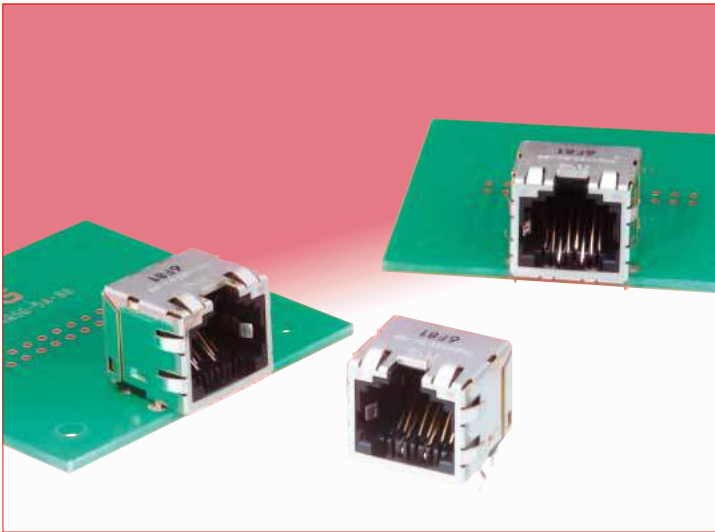

### ■ Features

#### 1. Unique contact configuration and board-mounting pattern

The adjacent contacts have different angles of engagement thus increasing the distance between them, in effect reducing the cross talk within connector and its footprint. Contact #3 and #6, affecting the cross talk the most; have been isolated from other contacts resulting in maximum NEXT noise suppression.

In addition, the board layout allows easy tracing of the differential signal lines.

#### 2. Full EMI shielding

The entire connector is covered with a metal shell. Multiple panel ground contact springs (2 on each side of the mating opening) and 4 board ground connection solder contacts placed at each corner of the connector guarantee effective suppression of noise radiation.

#### 3. Sequential mating

Separate ground springs make contact with the mating connector's ground before the signal contacts, allowing equalization of any ground differential.

#### 4. Conforms to FCC (Federal Communications Commission) standards

Meets requirements of FCC Title 47, Part 68, Subpart F.

#### 5. RoHS Compliant

Considering environment compatibility, substances prohibited by RoHS are not used.

### ■ Applications

LAN related equipment, measuring instruments, office equipment and other high transmission speed applications requiring use of high performance modular jacks.

### Unique Contact Configuration

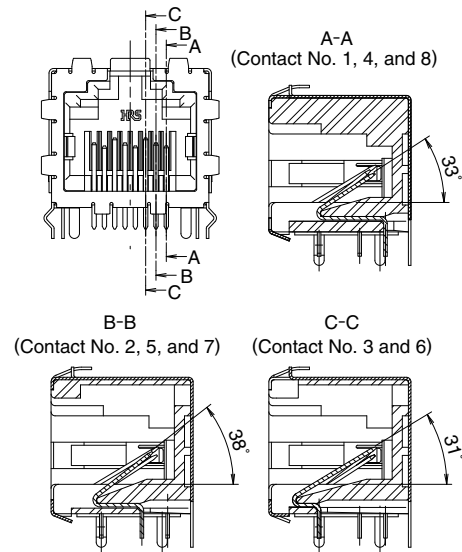

### Recommended board layout for differential routing

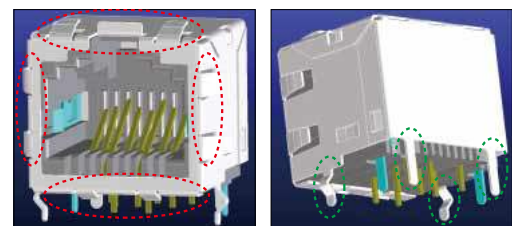
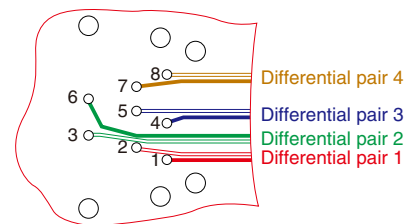

Panel ground contact springs

Board ground connection solder contacts

### Separate ground springs

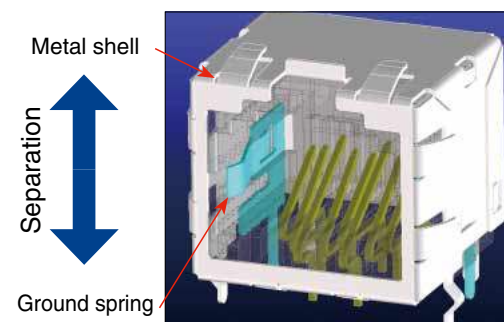

## Product Specifications

Ratings	Current rating 1A	Operating temperature range : -55 to +85°C (Note)
	Voltage rating 125V AC	Storage temperature range : -25 to +60°C

Item	Specification	Conditions
1. Insulation resistance	100MΩ min.	100V DC
2. Withstanding voltage (Basic terminal between 123-456-78)	No flashover or insulation breakdown.	500V AC / 1 minute
3. Withstanding voltage (Terminal to shield)	No flashover or insulation breakdown.	1500V AC / 1 minute
4. Contact resistance	50mΩ max.	100mA
5. Vibration	No electrical discontinuity of 5μs or more. No damage, cracks, or parts dislocation.	Frequency : 10 to 55Hz, single amplitude of 0.75mm, 3 axis, 10 cycles
6. Shock	No electrical discontinuity of 5μs or more. Contact resistance : 60m ohms max.	Acceleration of 490 m/s <sup>2</sup> , 11ms duration, sine half-wave waveform, 3 cycles / each of 6 axis
7. Durability (insertion/withdrawal)	Contact resistance : 60mΩ max.	700 cycles
8. Temperature cycle	Insulation resistance : 100MΩ min. Contact resistance : 60mΩ max.	(Temperature : -55°C → +15°C to +35°C → +85 → +15°C to +35°C Duration : 30 → 2 to 3 → 30 → 2 to 3 (Minutes) 5 cycles
9. Humidity	Insulation resistance : 1MΩ min. (High humidity) Insulation resistance : 10MΩ min. (Dry state)	500 hours at 40°C, HR 90% to 95%
10. Salt spray	Contact resistance : 60mΩ max.	5% water solution for 48 hours

Note : Includes temperature rise caused by current flow.  
Temperature range for mechanical operation : -25°C to +60°C

## Materials / Finish

Part	Material	Finish	Remarks
Insulator	PBT	Color: Black	UL94V-0
Contact	Phosphor bronze	Contact area : Gold plated 1.27 μm Termination area : Gold plated 0.03 μm Under plate : Nickel plated 1 μm	-
Shield	Brass	Tin reflow plated 1 μm	-
Ground spring	Phosphor bronze	Tin reflow plated 1 μm	-

## Product Number Structure

Refer to the chart below when determining the product specifications from the product number.  
Please select from the product numbers listed in this catalog when placing orders.

**TM24 R SG - 5A 8 8**

①      ②      ③                      ④      ⑤      ⑥

① Series name	: TM24
② Connector type	: R...Jack
③ Shell type	: SG...Separate ground spring –outer shell
④ Jack type	: 5A...Right-angle dip
⑤ Jack opening code	: 8...8 contacts
⑥ Number of inserted contact	: 8...8 contacts

## ■ Modular Jack Connectors

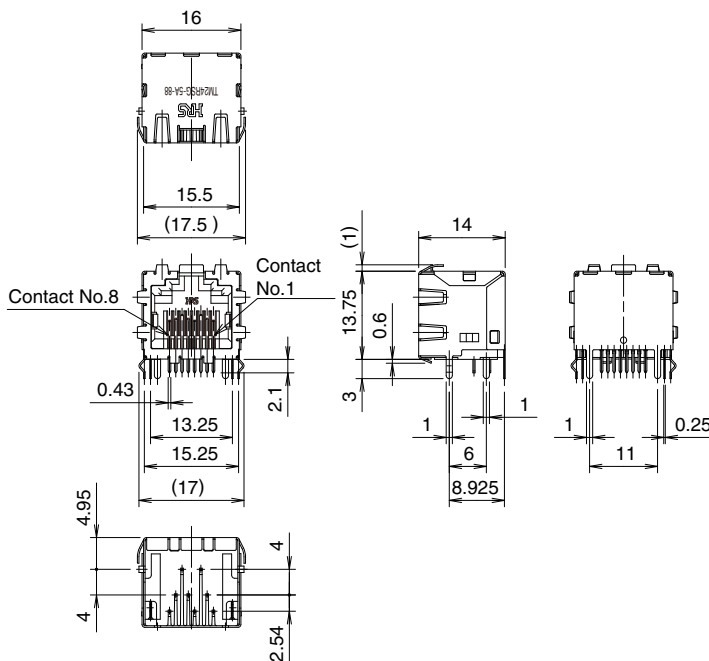

Part No.	HRS No.	RoHS
TM24RSG-5A-88	222-2946-7	YES

### ◆ Recommended PCB mounting pattern

### ◆ Recommended panel cutout

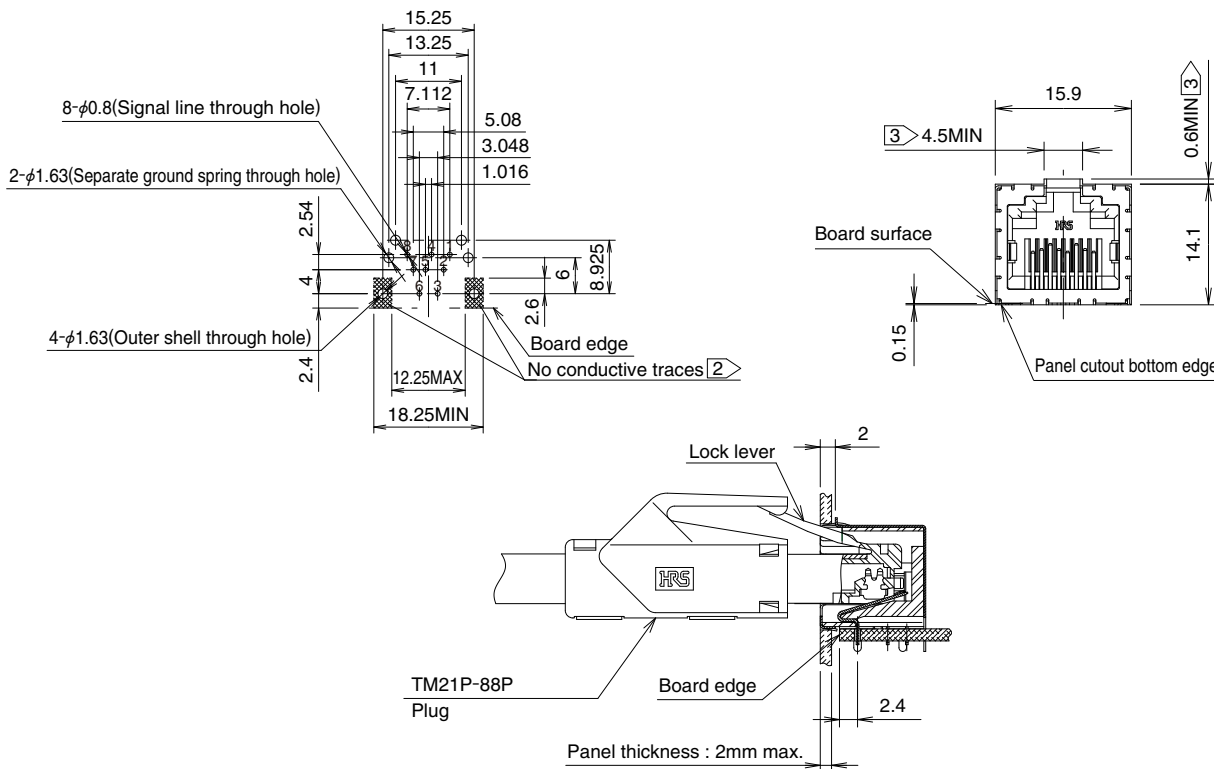

\* Precautions and recommendations for board and panel design

- 1 . Recommended board thickness : 1.6mm.
- 2 . No conductive traces in the crosshatched areas.
- 3 . Make sure that the panel cutout has enough clearance to assure free operation of the lock lever of the mating plug.
- 4 . Make sure that the panel cutout bottom edge is 0.15mm below the board-mounting surface.
- 5 . Connector can be cleaned with isopropyl alcohol (IPA) at room temperature.

