

LOC		DIST		REVISIONS			
P	LTN	DESCRIPTION	DATE	DWN	APVD		
B		REVISED PER ECR-16-003314	18JUL2016	BW	GJ		
B1		REVISED PER ECR-18-002671	07NOV2018	BKW	GJ		

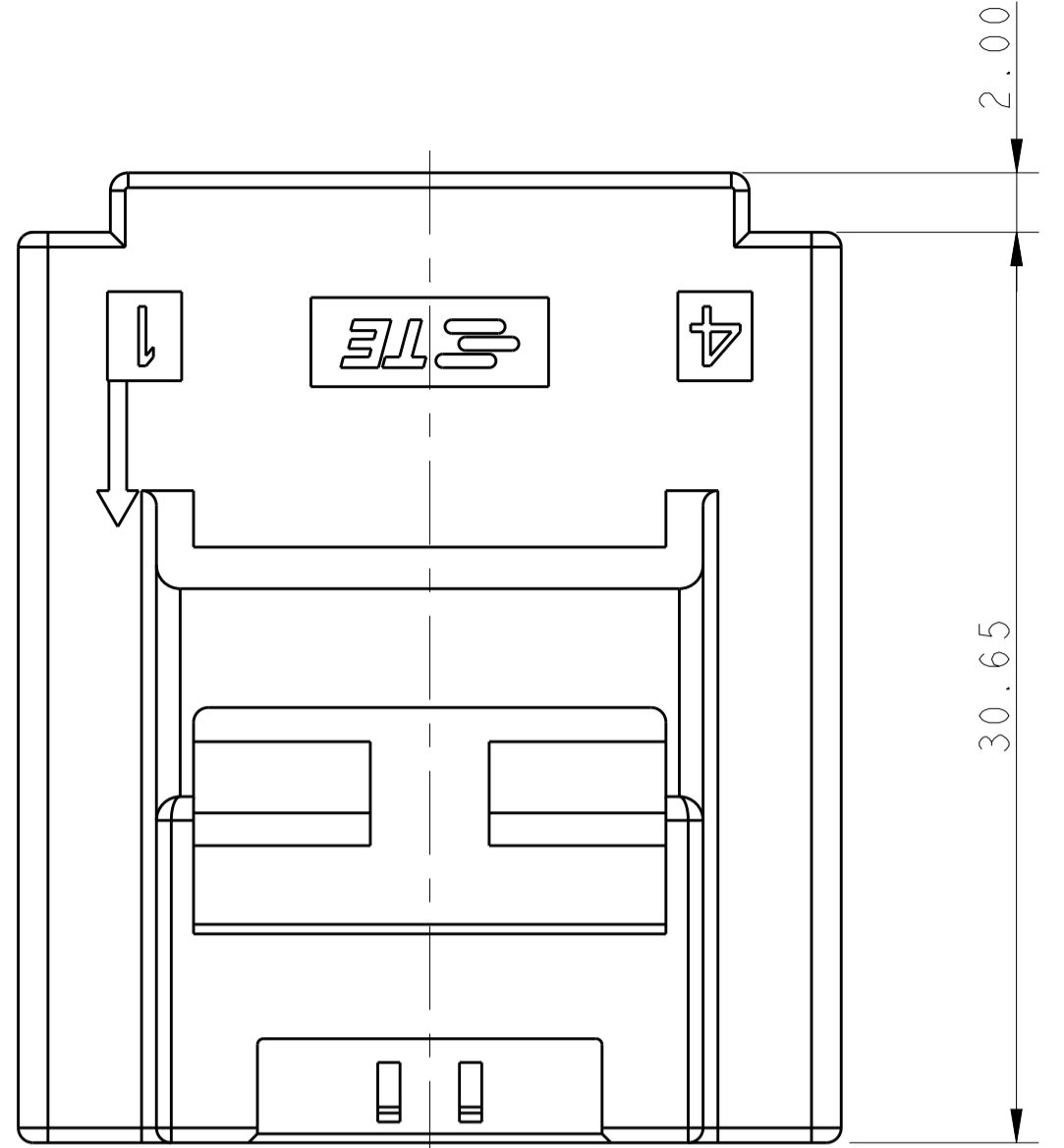

POS.	DIM.A	DIM.B	DIM.C
1*5	33.70	27.50	31.30
1*4	27.70	21.50	25.30
1*3	21.70	15.50	19.30
1*2	15.70	9.50	13.30

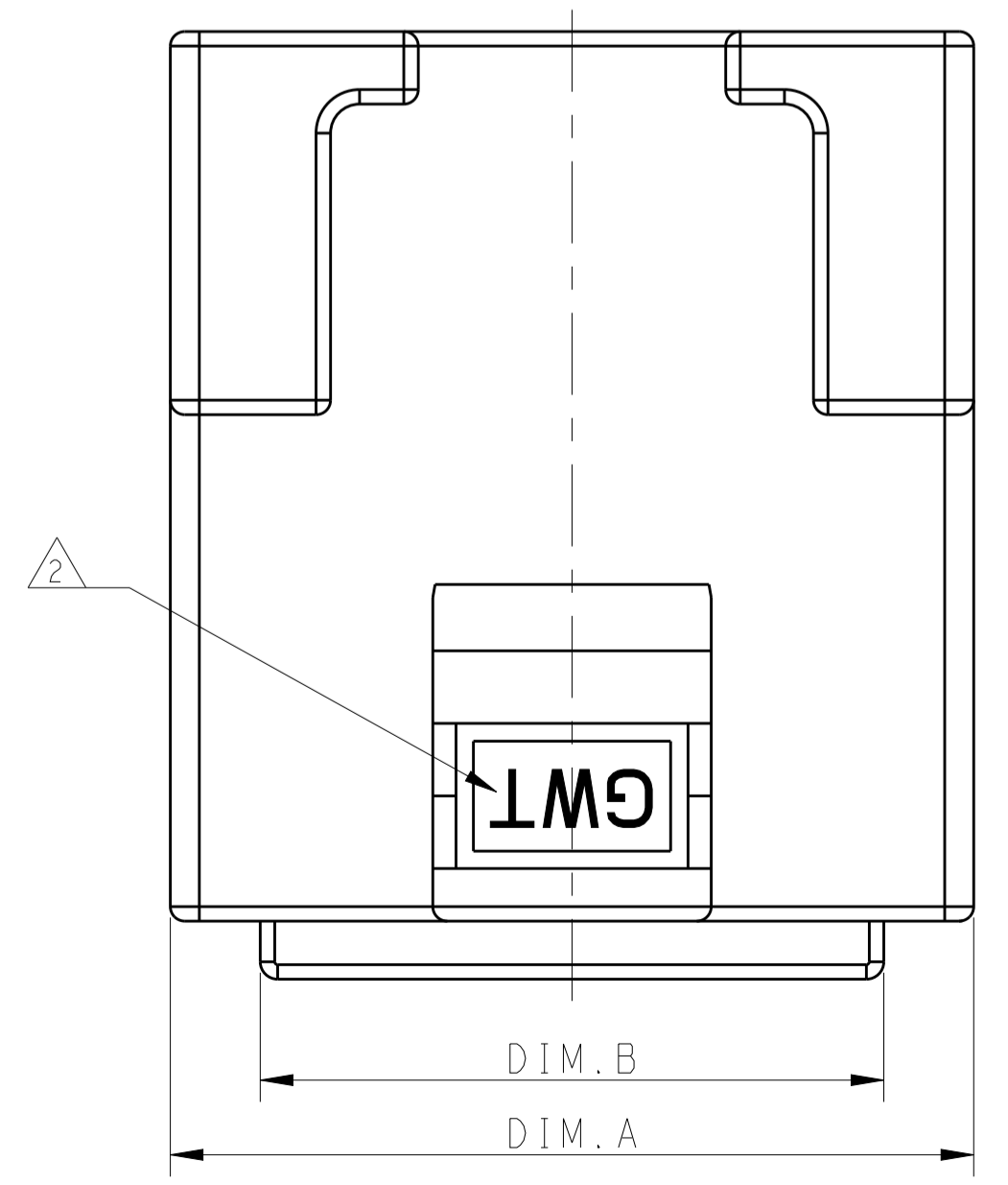
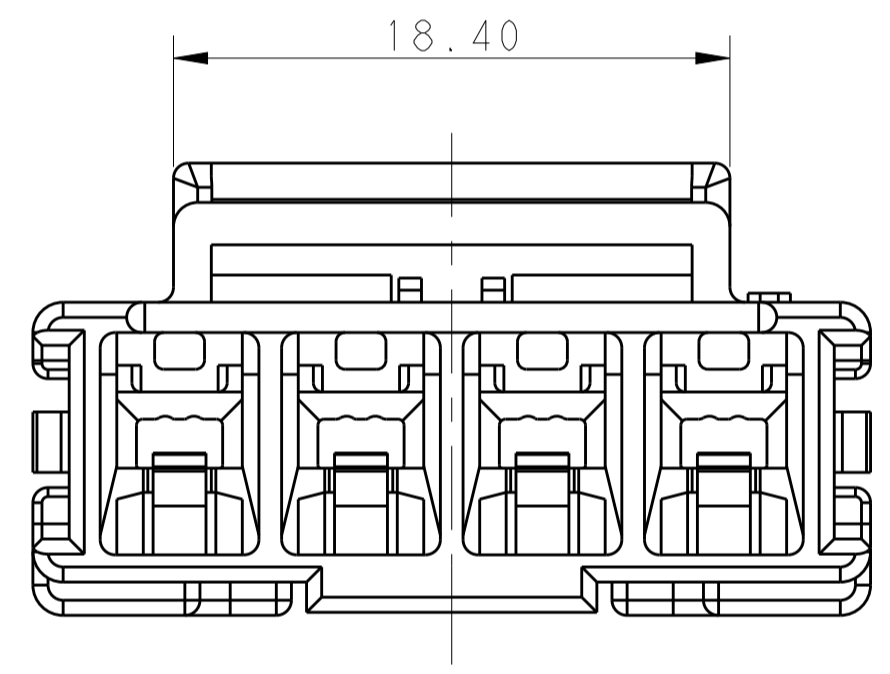
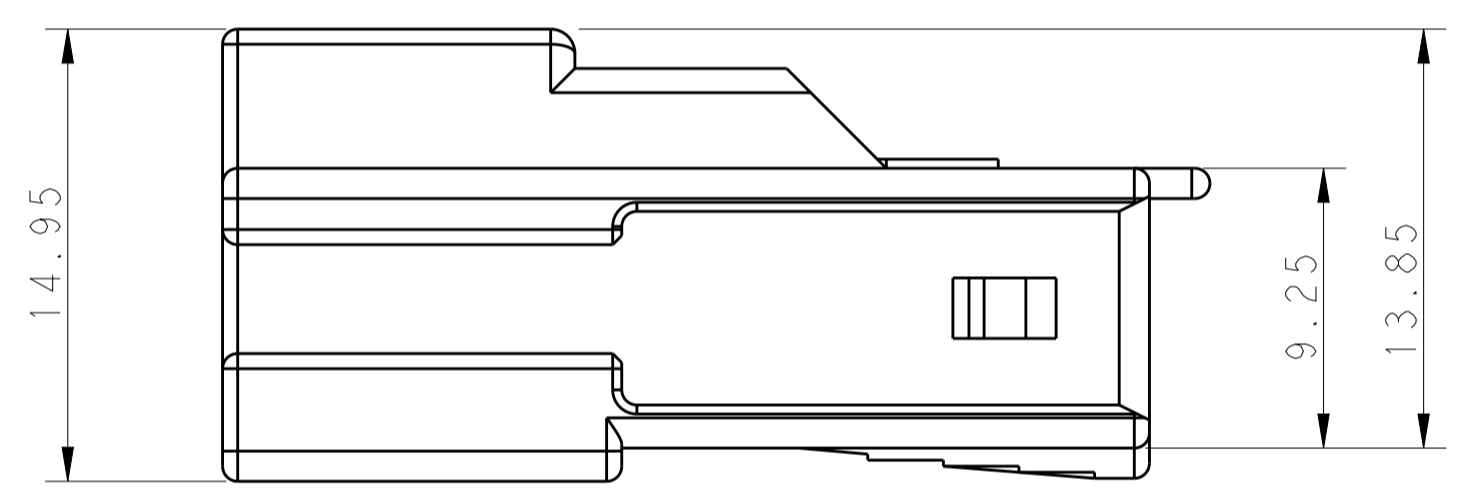
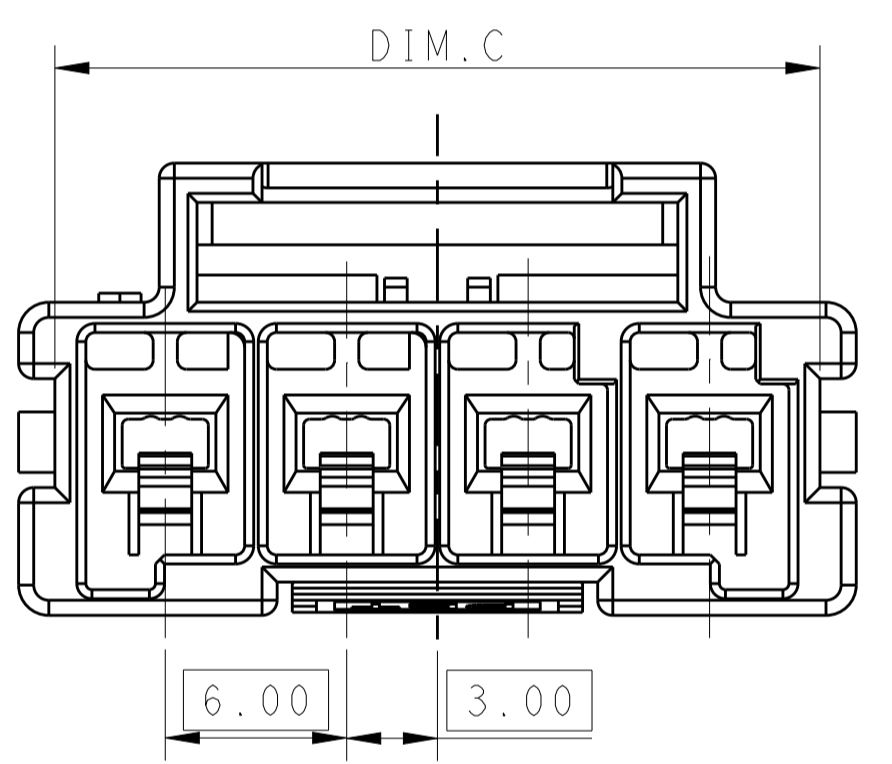

- MATERIAL:
 LEVEL A: PA6 GLASS FILLED, COMPLY WITH GLOW WIRE REQUIREMENTS FOR PARTS OF NON-METALLIC MATERIAL SUPPORTING A CURRENT-CARRYING CONNECTION DETAILED IN IEC 60335-1, SECTION 30 (GWT), UL 94V-0
 LEVEL B: PBT GLASS FILLED, HOT WIRE IGNITION (HWI) VERSION ARE MOLDED IN A RESIN THAT COMPLIES WITH TE HOT WIRE IGNITION TEST 109-32026 AND ARE RECOMMENDED FOR USE WITH HWI HOUSINGS THAT ALSO COMPLY, UL 94V-0
- MATERIAL MARK:
 LEVEL A: GWT, LEVEL B: HWT
- APPLICABLE CONTACT P/N
 TAB CONTACT: 1971238/1971780/82/84/86/88-*, 2238067-*
- MATING CONN, P/N
 PLUG HSG: *-2232265-*,
 TPA (LOCK PLATE): *-1971777-*

5. This product has not completed validation testing.

THIS DRAWING IS A CONTROLLED DOCUMENT.		DWN: TOMMY WU 26MAR2013	TE Connectivity
DIMENSIONS:		CHK: HAPYE WU 26MAR2013	
mm	TOLERANCES UNLESS OTHERWISE SPECIFIED:	APVD: YUHONG MAO 26MAR2013	NAME: CAP HOUSING, FREE HANGING, SINGLE ROW POWER TRIPLE LOCK
0 PLC	±	PRODUCT SPEC	SIZE: CAGE CODE DRAWING NO
2 PLC	±0.35	108-106118	RESTRICTED TO
3 PLC	±0.25	APPLICATION SPEC	A100779C=2232358
4 PLC	±	114-106118	SCALE: SHEET 1 OF 2 REV: B1
ANGLES	±	WEIGHT	Customer Drawing
MATERIAL	FINISH		

LOC		DIST		REVISIONS			
				REV	DESCRIPTION	DATE	BY
-	-	-	-	-	SEE SHEET 1	-	-

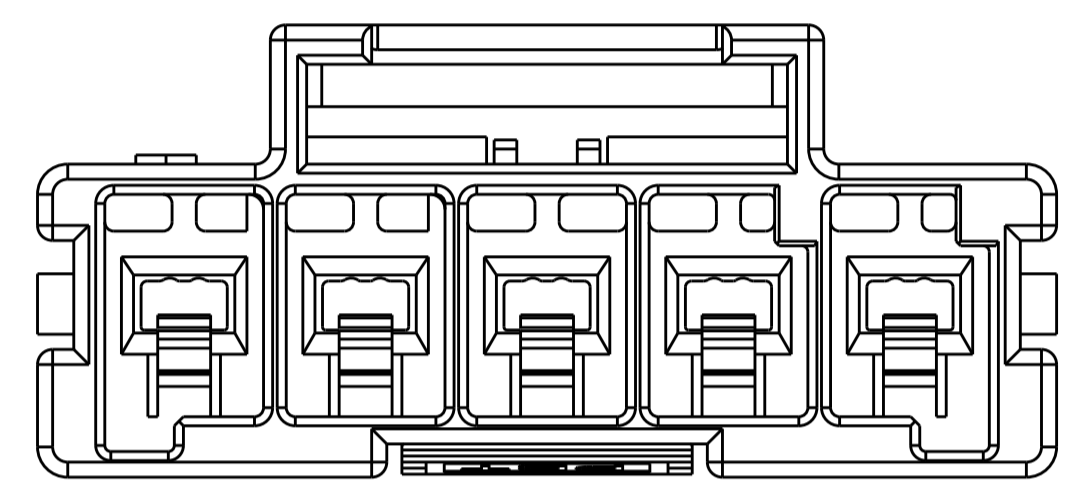
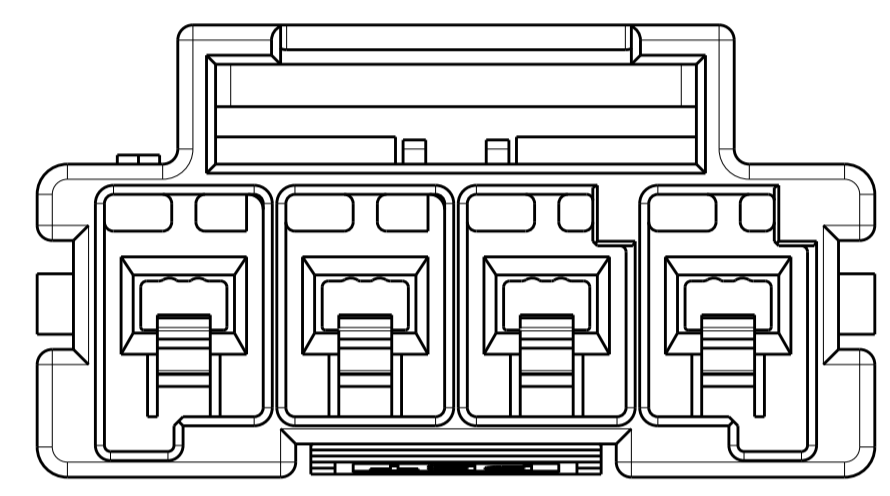
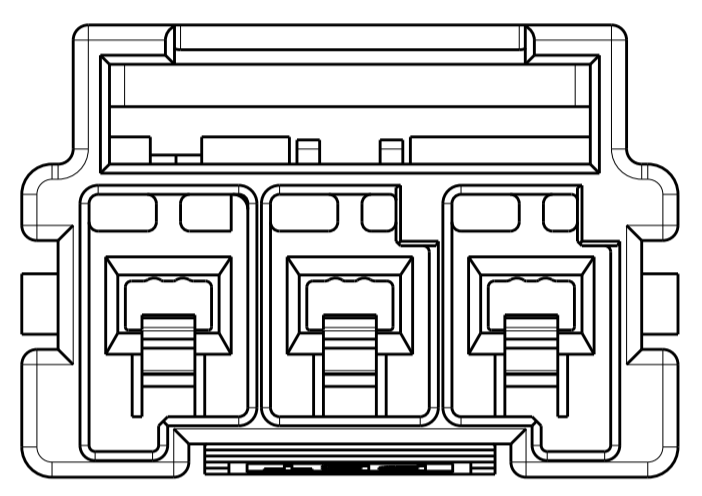
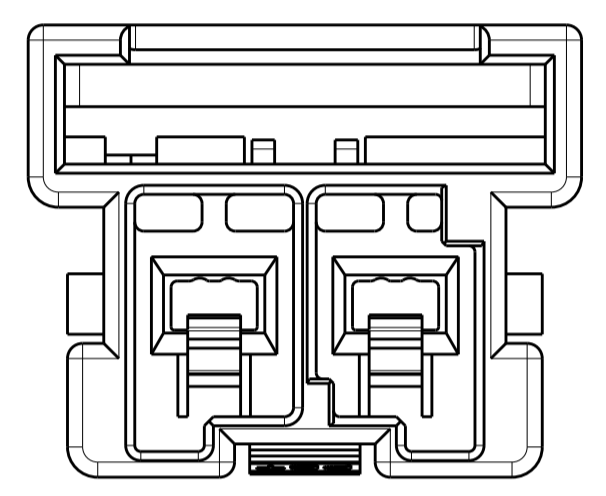
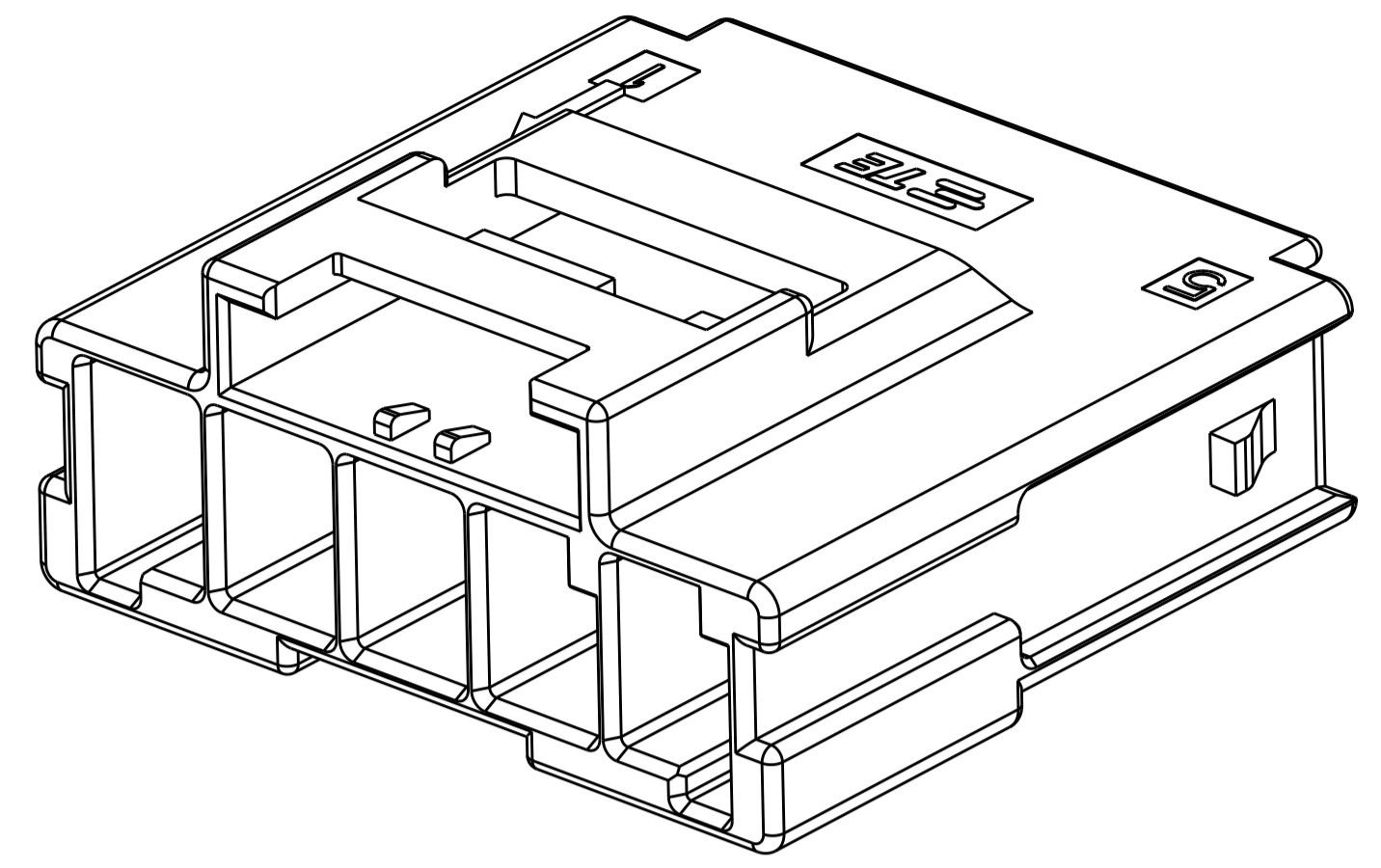
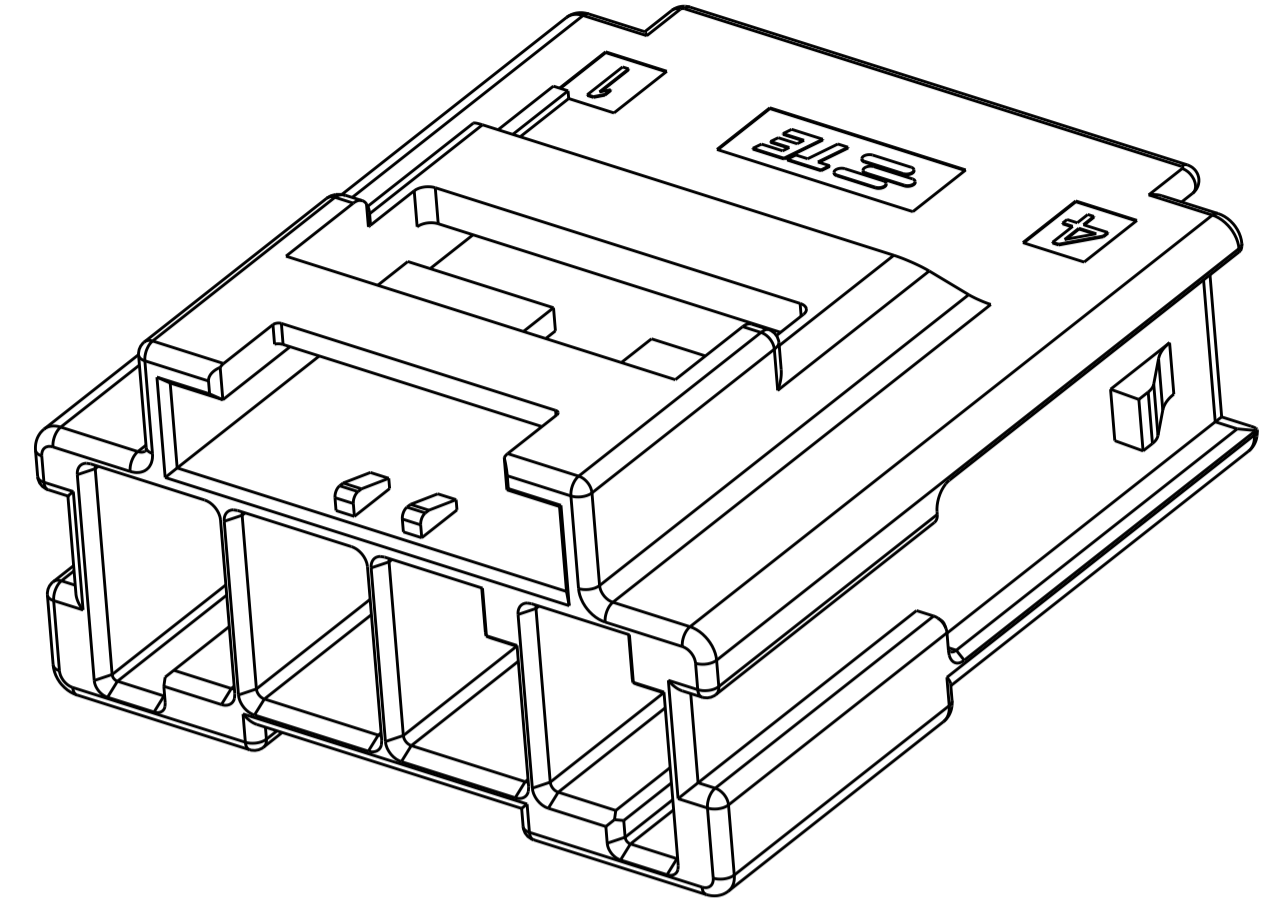
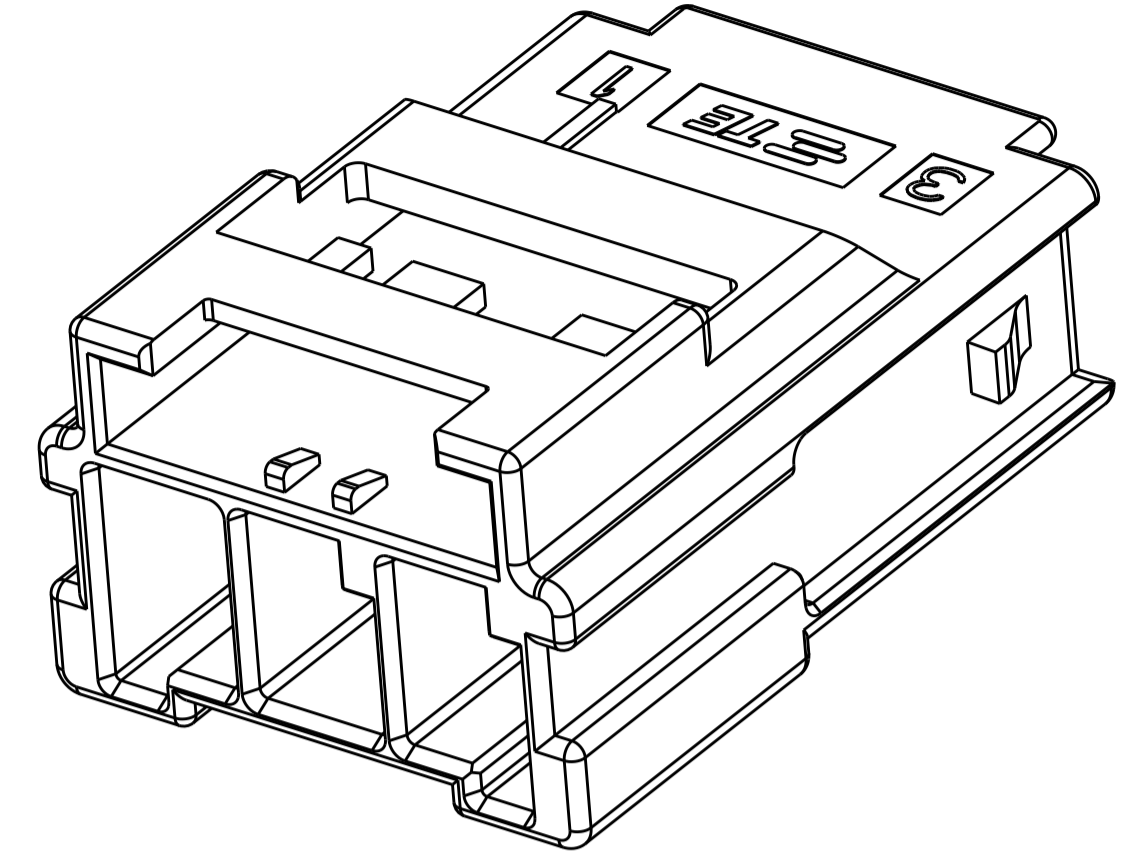
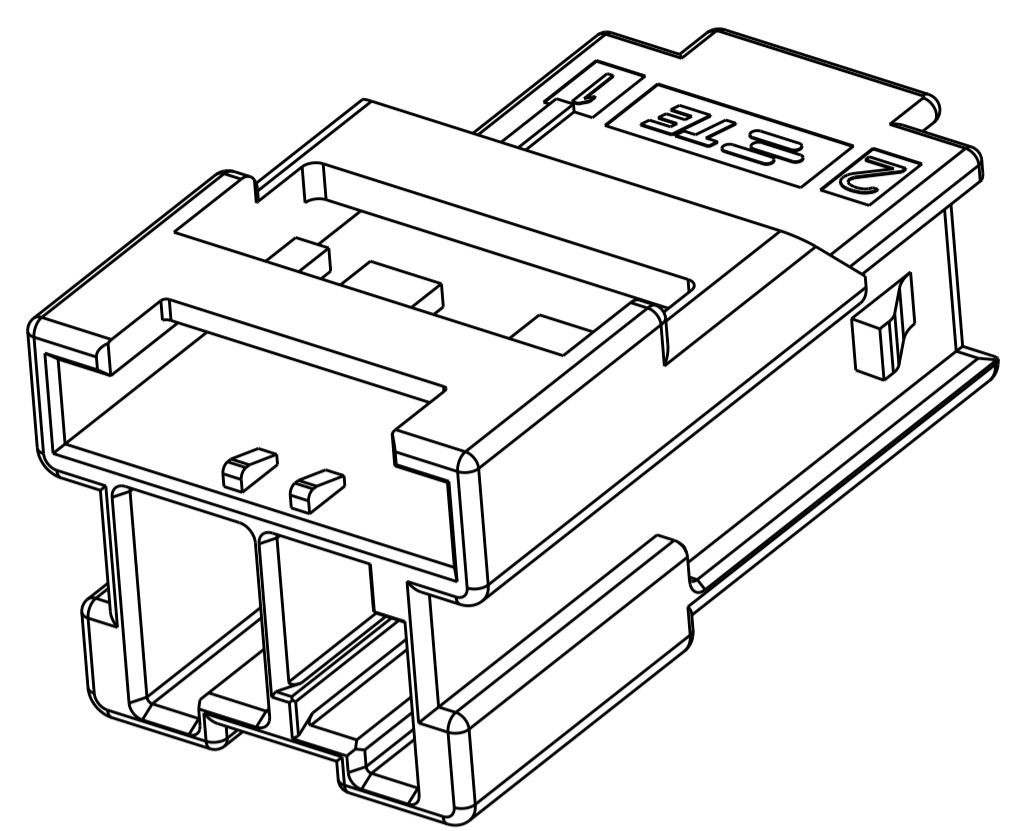

1*2 POSITIONS

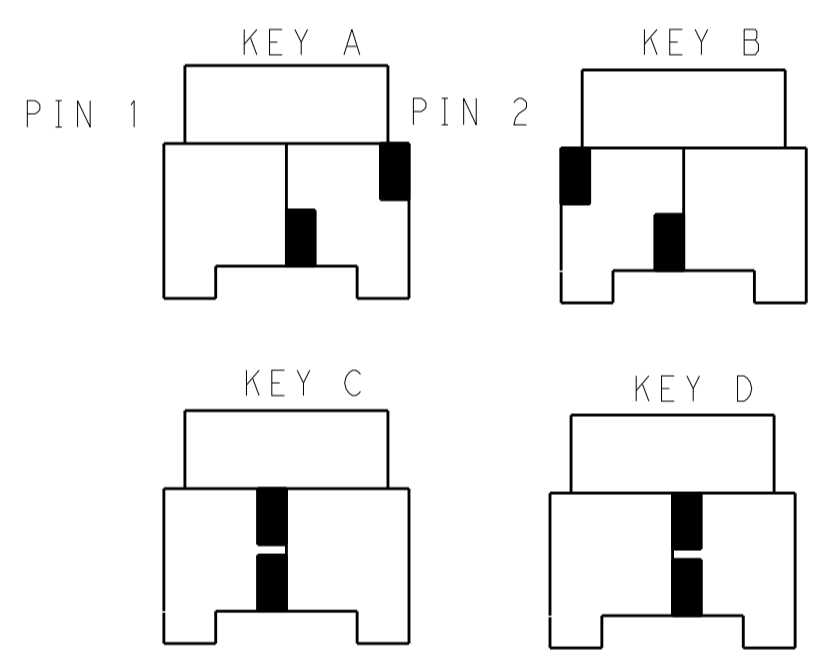

KEYING FOR 1*2 POS.

1*3 POSITIONS

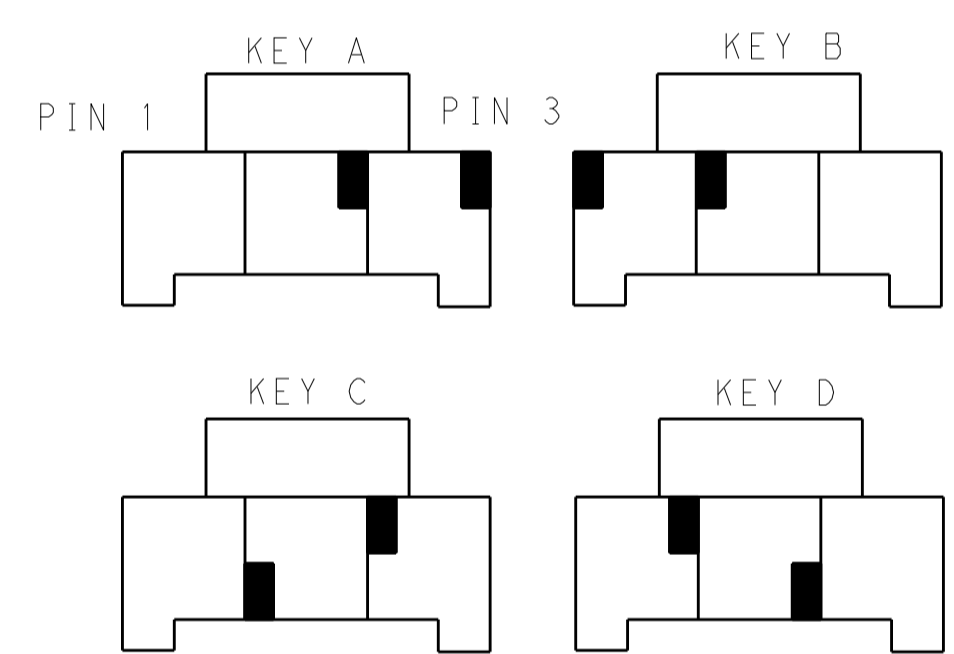

KEYING FOR 1*3 POS.

1*4 POSITIONS

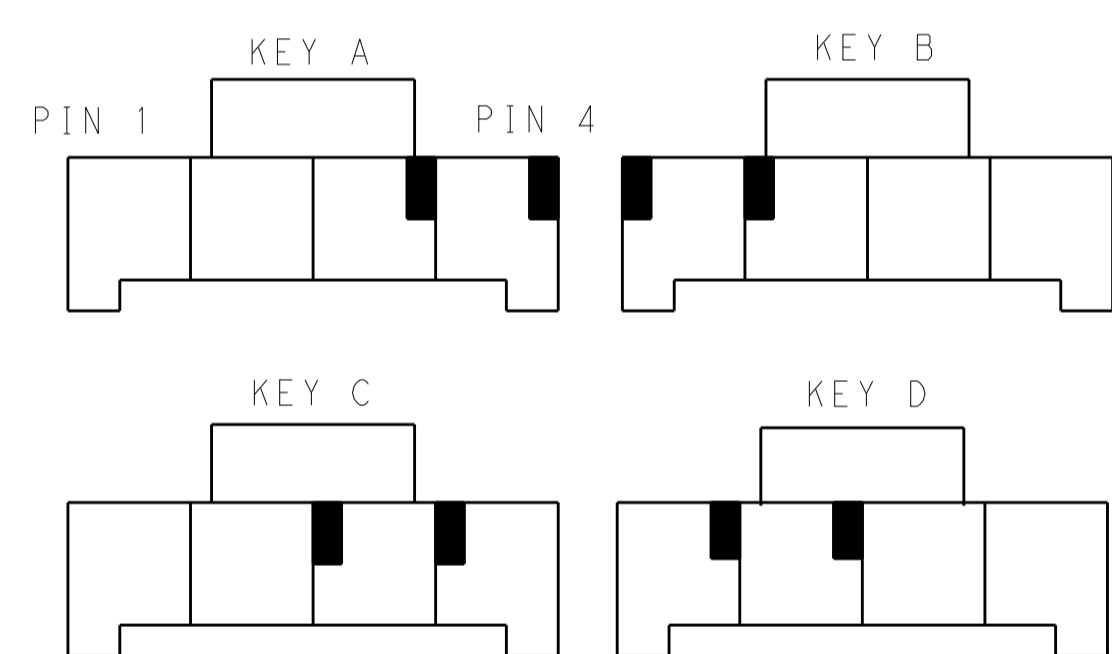

KEYING FOR 1*4 POS.

1*5 POSITIONS

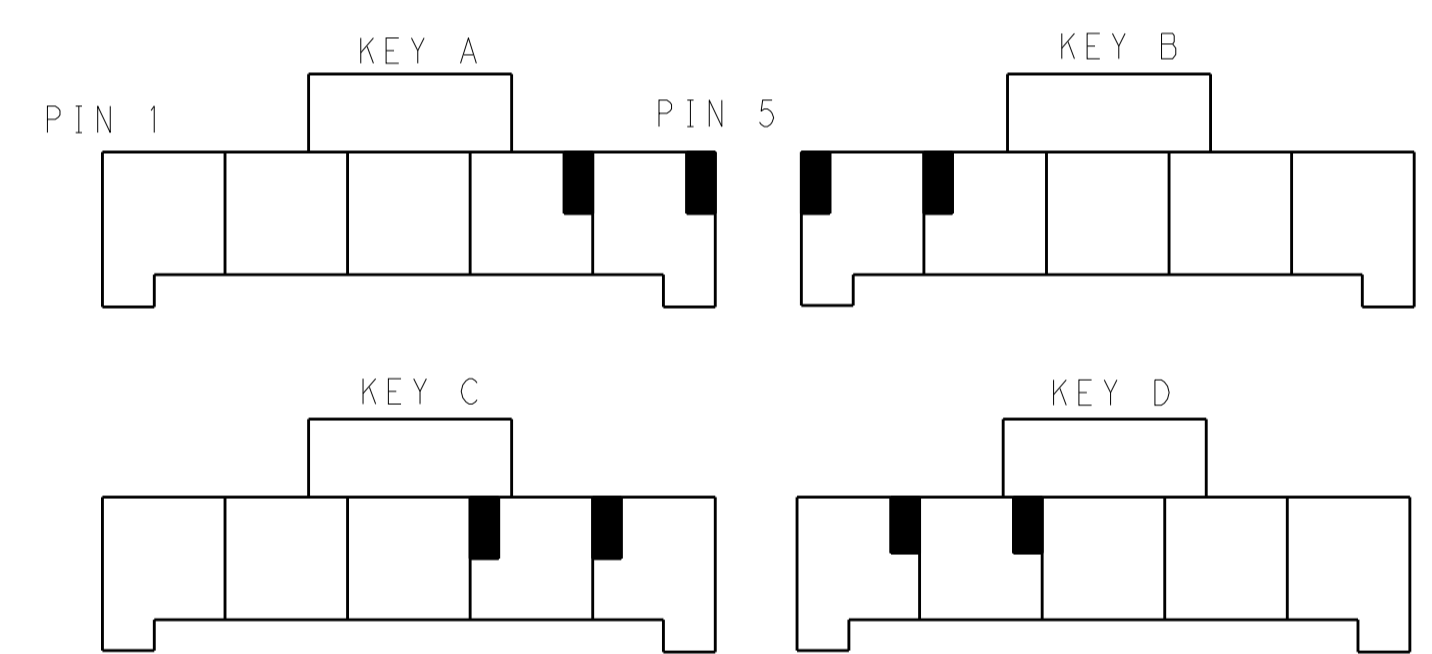

KEYING FOR 1*5 POS.

POS.	MATERIAL	COLOR	KEY	P/N
1*5	LEVEL A	DARK GREY	KEY A	5-2232358-7
		BROWN	KEY B	6-2232358-7
		GREEN	KEY C	7-2232358-7
		ORANGE	KEY D	8-2232358-7
1*4	LEVEL A	DARK GREY	KEY A	5-2232358-4
		BROWN	KEY B	6-2232358-4
		GREEN	KEY C	7-2232358-4
		ORANGE	KEY D	8-2232358-4
1*4	LEVEL B	BLACK	KEY A	1-2232358-3
		DARK GREY	KEY A	5-2232358-3
		BROWN	KEY B	6-2232358-3
		GREEN	KEY C	7-2232358-3
1*3	LEVEL A	ORANGE	KEY D	8-2232358-3
		DARK GREY	KEY A	5-2232358-2
		BROWN	KEY B	6-2232358-2
		GREEN	KEY C	7-2232358-2
1*2	LEVEL A	ORANGE	KEY D	8-2232358-2

**SUPERSEDED BY POWER TRIPLE LOCK
PANEL MOUNT CAPS X-2232263-X**

THIS DRAWING IS A CONTROLLED DOCUMENT.		DWN: TOMMY_WU 26MAR2013 CHK: HAPYE_WU 26MAR2013 APVD: YIHONG_MAO 26MAR2013	TE Connectivity
DIMENSIONS: mm 	TOLERANCES UNLESS OTHERWISE SPECIFIED: 0 PLC ±0.35 1 PLC ±0.25 2 PLC ±0.25 3 PLC ±0.25 4 PLC ±0.25 ANGLES ±0.5°	NAME: CAP HOUSING, FREE HANGING, SINGLE ROW POWER TRIPLE LOCK PRODUCT SPEC: 108-106118 APPLICATION SPEC: 114-106118	
MATERIAL: -	FINISH: -	SIZE: A1 CAGE CODE: 00779 DRAWING NO: C=2232358 WEIGHT: - Customer Drawing	RESTRICTED TO: - SCALE: - SHEET 2 OF 2 REV: BI