

MOD		LOC		DIST		ZONE		LTR		REVISIONS		
4	BD	39	P	F						DESCRIPTION	DATE	APPD
									U	ADDED -8 PER NPR 4680 AND REDRAWN ON CAD	04/06/93	-
									U1	REVISED PER ECO-09-020935	08SEP09	KK AEG

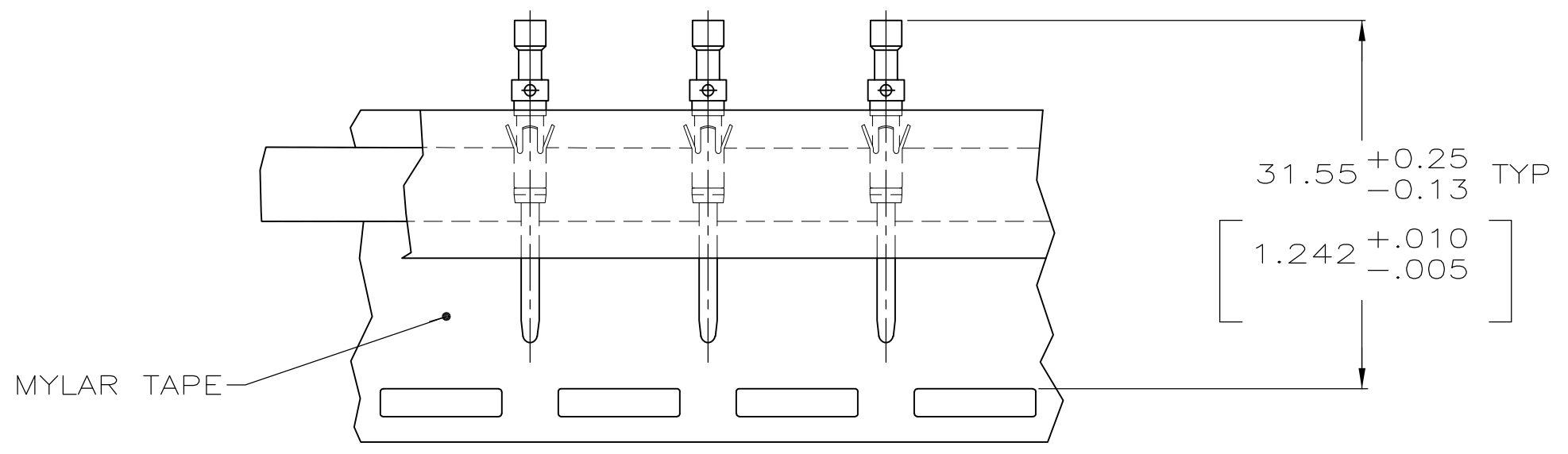
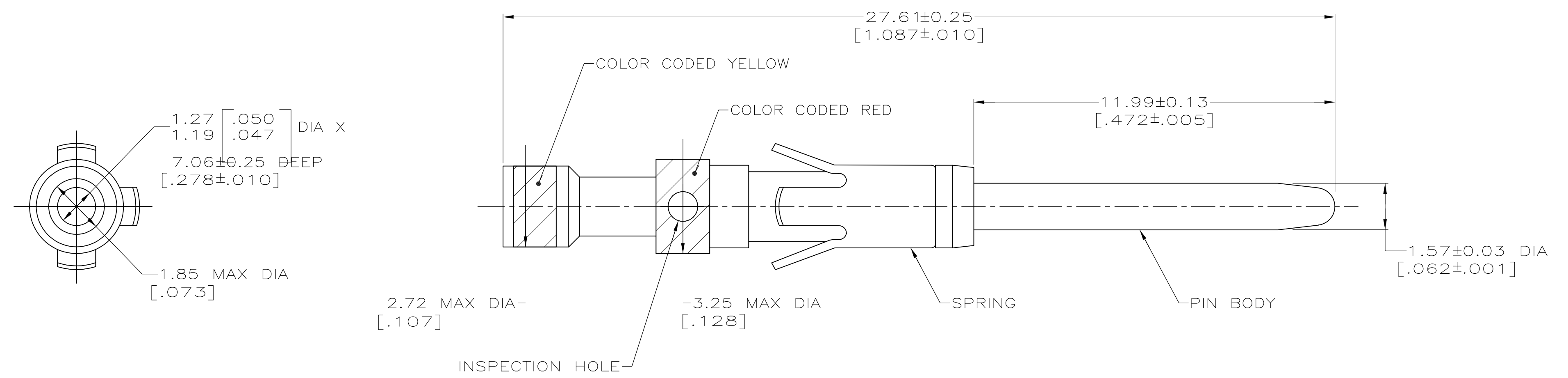

TAPE MTG DETAIL
SCALE 2:1

- ① 0.76µm [.000030] MIN GOLD OVER 1.27µm [.000050] MIN NICKEL.
- ② WHEN ORDERING CONTACT ASSEMBLY ON TAPE, ORDER BY THE TAPE NUMBER PLUS THE PACKAGING CODE AS FOLLOWS:
 1. FOR USE WITH AMP TAPETRONIC, PNEUMATIC TOOL-
 - A. 1000 PARTS TO A BOX ADD PACKAGING CODE: 1MBOX
 2. FOR USE WITH 4/8 INDENT STRIPPER CRIMPER-
 - A. 1000 PARTS TO A REEL ADD PACKAGING CODE: 1MREEL
 - B. 5000 PARTS TO A REEL ADD PACKAGING CODE: 5MREEL
- ③ OBSOLETE PARTS: OBSOLETE CIS STREAMLINING PER D.RENAUD/D.SINISI

③ OBSOLETE	SMALL PACK	-201578-8-
	TAPE MTG (SEE DETAIL) ②	201578-4
	STANDARD	201578-1
	PACKAGING TYPE	PART NO

DO NOT SCALE PRINT. UNLESS SPECIFIED DIMENSIONS IN mm [INCHES] TOLERANCES ON :	DR 04/06/93 D.GELTZ	AMP Incorporated Harrisburg, PA 17105-3608		
2 PLC DEC ± -	CHK 4-26-93 R.STONE			
3 PLC DEC ± -	APPD 4-29-93 R.S.KLINE	NAME		
ANGLES ± -	APPD -	CONTACT ASSEMBLY, PIN, #16, 20-24 AWG, TYPE II		
MATERIAL	PRODUCT SPEC -			
PIN BODY: COPPER ALLOY	APPLICATION SPEC -	SIZE	CAGE CODE	DRAWING NO
SPRING: STAINLESS STEEL	FINISH	③	00779	③-201578
PIN BODY: ③	WEIGHT -	SCALE	10:1	SHEET 1 OF 1

THIS DRAWING IS A CONTROLLED DOCUMENT FOR AMP INCORPORATED. IT IS SUBJECT TO CHANGE AND THE CONTROLLING ENGINEERING ORGANIZATION SHOULD BE CONTACTED FOR THE LATEST REVISION.