

DESIGNED AND DIMENSIONED IN MILLIMETERS [INCHES]  
 ALL DIMENSIONS REFERENCE EXCEPT AS SHOWN

UCC8-XXX-X-XXX-X-X-A-XX

DO NOT SCALE FROM THIS PRINT

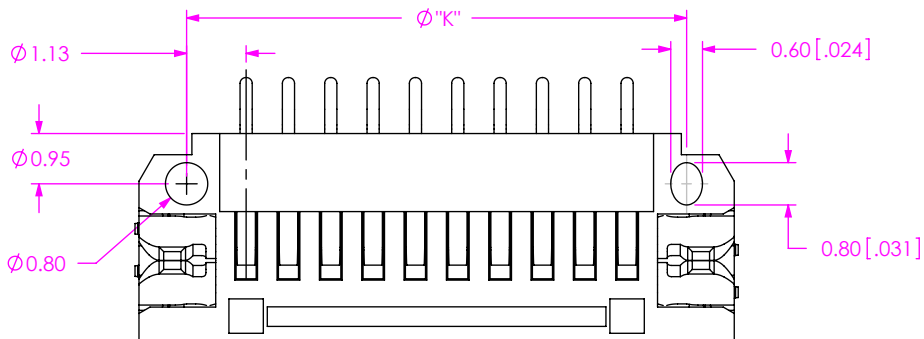
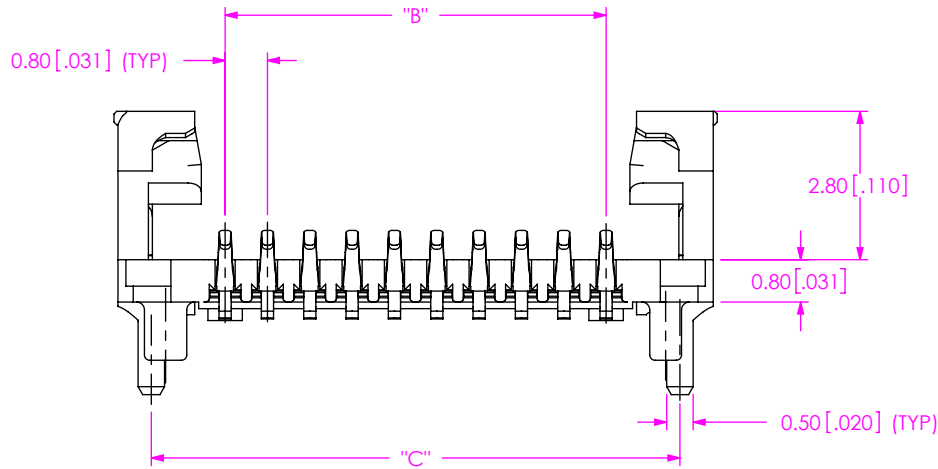
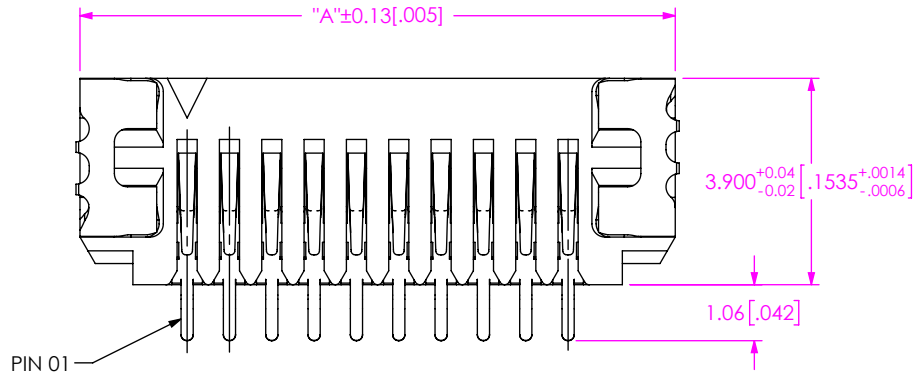

No OF POSITIONS  
 -010, \*-014,  
 \*-020, \*-028  
 (TOTAL)

LEAD STYLE  
 -1: -1.05 HEIGHT

PLATING SPECIFICATION  
 -H: 30µ" GOLD ON THE CONTACT AREA,  
 GOLD FLASH ON THE TAILS,  
 MATTE TIN ON THE WELD TAB  
 -STL: 30µ" GOLD ON THE CONTACT AREA,  
 TIN-LEAD ON THE TAILS,  
 TIN-LEAD ON THE WELD TAB

TAPE & REEL (SEE NOTES 4 & 5)  
 BLANK: TAPE & REEL  
 -FR: FULL REEL QTY TAPE & REEL

ALIGNMENT PIN  
 -A: ALIGNMENT PIN

WELD TAB  
 -1: THRU HOLE  
 \*\*2: SURFACE MOUNT  
 (\*\* = SEE NOTE 3)

ROW SPECIFICATION  
 -S: SINGLE ROW

(\* = NOT TOOLED)

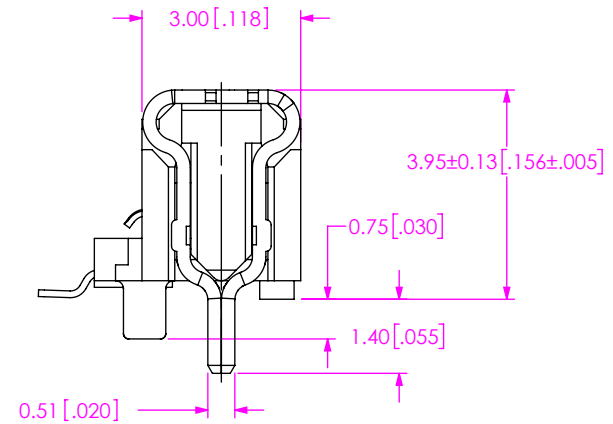

FIG 1  
 UCC8-010-1-XXX-S-1-A SHOWN  
 (PPP NOT SHOWN FOR CLARITY)

| TABLE 1   |               |               |               |               |               |
|-----------|---------------|---------------|---------------|---------------|---------------|
| No OF POS | "A"           | "B"           | "C"           | "K"           | "L"           |
| -010      | 11.25 [0.443] | 7.20 [0.283]  | 10.00 [0.394] | 9.45 [0.372]  | 11.25 [0.443] |
| -014      | 14.45 [0.569] | 10.40 [0.409] | 13.20 [0.520] | 12.65 [0.498] | 14.45 [0.569] |
| -020      | 22.00 [0.866] | 17.95 [0.707] | 20.75 [0.817] | 20.20 [0.795] | 22.00 [0.866] |
| -028      | 28.40 [1.118] | 24.35 [0.959] | 27.15 [1.069] | 26.60 [1.047] | 28.40 [1.118] |

NOTES:

- NOTE DELETED.
- NOTE DELETED.
- AVAILABLE FOR EXISTING CUSTOMERS ONLY.
- ORDERS WILL BE PACKAGED ACCORDING TO THE SAMTEC PACKAGING EFFICIENCY STANDARDS (SPES) FOUND ON WWW.SAMTEC.COM.
- ATTACH LABEL TO EACH REEL.

PROPRIETARY NOTE  
 THIS DOCUMENT CONTAINS CONFIDENTIAL AND PROPRIETARY INFORMATION AND ALL DESIGN, MANUFACTURING, REPRODUCTION, USE, PATENT RIGHTS AND SALES RIGHTS ARE EXPRESSLY RESERVED BY SAMTEC, INC. THIS DOCUMENT SHALL NOT BE DISCLOSED, IN WHOLE OR PART, TO ANY UNAUTHORIZED PERSON OR ENTITY NOR REPRODUCED, TRANSFERRED OR INCORPORATED IN ANY OTHER PROJECT IN ANY MANNER WITHOUT THE EXPRESS WRITTEN CONSENT OF SAMTEC, INC.

DO NOT SCALE DRAWING  
 SHEET SCALE: 8:1  
 MATERIAL:  
 INSULATOR: LCP, COLOR: BLACK  
 CONTACT: BeCu  
 WELD TAB: COPPER ALLOY



520 PARK EAST BLVD, NEW ALBANY, IN 47150  
 PHONE: 812-944-6733 FAX: 812-948-5047  
 e-Mail info@SAMTEC.com code 55322

DESCRIPTION:  
 0.8MM UCC8 SOCKET ASSEMBLY  
 DWG. NO.  
 UCC8-XXX-X-XXX-X-X-A-XX

BY: ETHAN C 02/24/2020 SHEET 1 OF 4

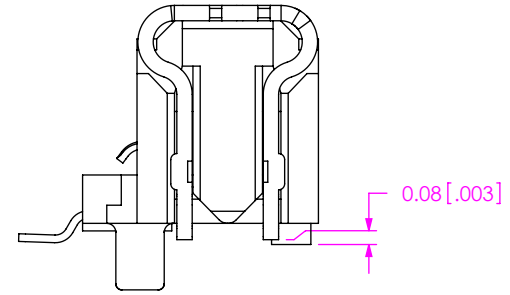
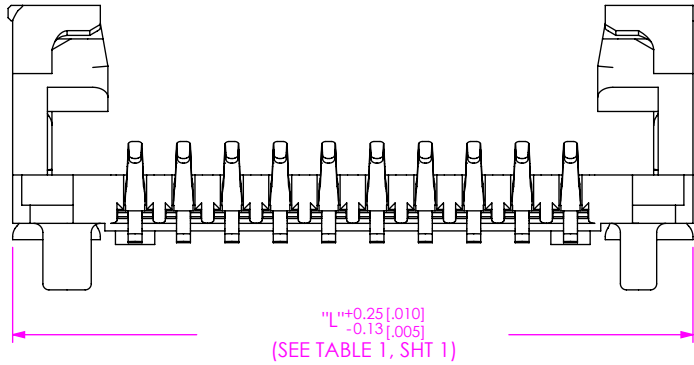

FIG 2  
 UCC8-010-1-XXX-S-2-A SHOWN  
 (DIFFERENT AS SHOWN, OTHERWISE SAME AS FIG 1)  
 (PPP NOT SHOWN FOR CLARITY)  
 (SEE NOTE 3)

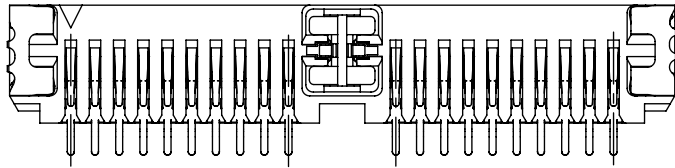
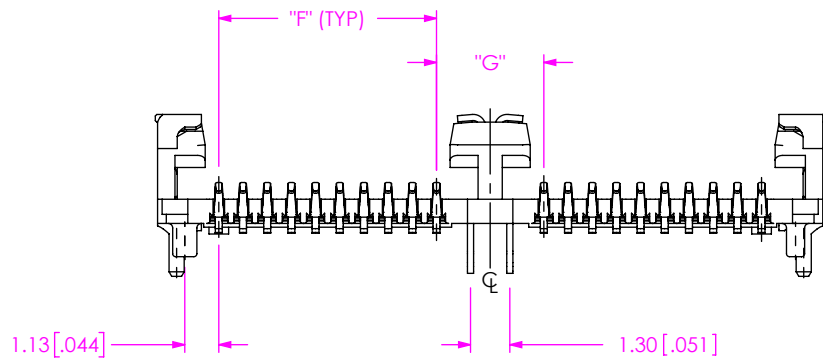

FIG 3  
 UCC8-020-1-XXX-S-1-A SHOWN  
 (DIFFERENT AS SHOWN, OTHERWISE SAME AS FIG 1)  
 (PPP NOT SHOWN FOR CLARITY)



| TABLE 2   |               |              |
|-----------|---------------|--------------|
| No OF POS | "F"           | "G"          |
| -020      | 7.20 [0.283]  | 3.55 [0.140] |
| -028      | 10.20 [0.402] | 3.35 [0.132] |

**PROPRIETARY NOTE**  
 THIS DOCUMENT CONTAINS CONFIDENTIAL AND PROPRIETARY INFORMATION AND ALL DESIGN, MANUFACTURING, REPRODUCTION, USE, PATENT RIGHTS AND SALES RIGHTS ARE EXPRESSLY RESERVED BY SAMTEC, INC. THIS DOCUMENT SHALL NOT BE DISCLOSED, IN WHOLE OR PART, TO ANY UNAUTHORIZED PERSON OR ENTITY NOR REPRODUCED, TRANSFERRED OR INCORPORATED IN ANY OTHER PROJECT IN ANY MANNER WITHOUT THE EXPRESS WRITTEN CONSENT OF SAMTEC, INC.



520 PARK EAST BLVD, NEW ALBANY, IN 47150  
 PHONE: 812-944-6733 FAX: 812-948-5047  
 e-Mail info@SAMTEC.com code 55322

DO NOT SCALE DRAWING

SHEET SCALE: 8:1

DESCRIPTION:  
 0.8MM UCC8 SOCKET ASSEMBLY

DWG. NO.  
**UCC8-XXX-X-XXX-X-X-A-XX**

BY: ETHAN C 02/24/2020 SHEET 2 OF 4

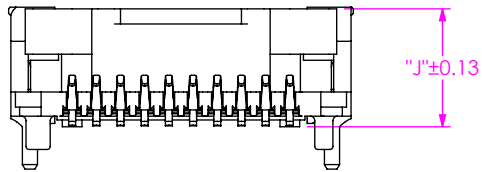
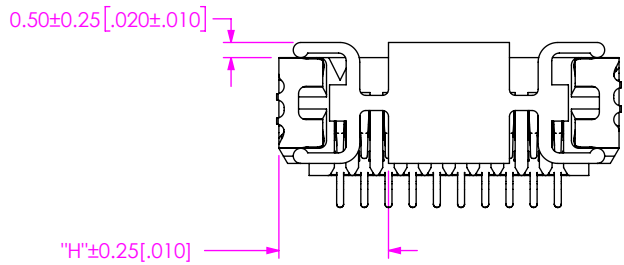

**FIG 4**  
 PICK AND PLACE PAD  
 UCC8-010-1-XXX-S-1-A SHOWN  
 (DIFFERENT AS SHOWN, OTHERWISE SAME AS FIG 1;  
 USE PPP-73-XXX FOR BOTH -1 & -2 WELD TAB LEAD STYLES)

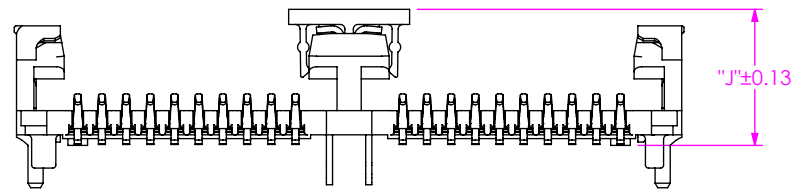
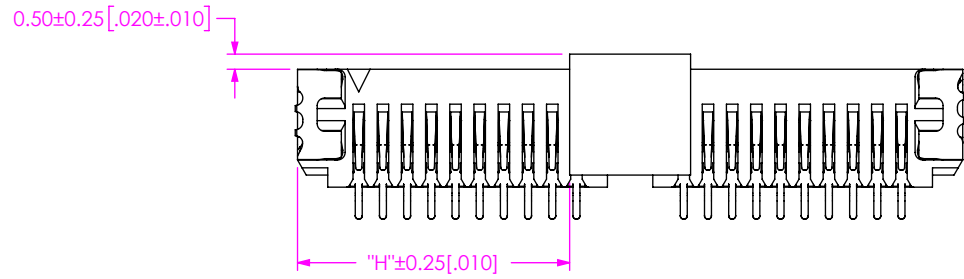

**FIG 5**  
 PICK AND PLACE PAD  
 UCC8-020-1-XXX-S-1-A SHOWN  
 (DIFFERENT AS SHOWN, OTHERWISE SAME AS FIG 1)

| TABLE 6   |               |               |
|-----------|---------------|---------------|
|           | "H"           | "J"           |
| No OF POS | LEAD STYLE -1 | LEAD STYLE -1 |
| -010      | 3.63 [0.143]  | 3.90 [0.154]  |
| -014      | 5.13 [0.202]  |               |
| -020      | 9.00 [0.354]  | 4.45 [0.175]  |
| -028      | 12.00 [0.472] |               |

**PROPRIETARY NOTE**  
 THIS DOCUMENT CONTAINS CONFIDENTIAL AND PROPRIETARY INFORMATION AND ALL DESIGN, MANUFACTURING, REPRODUCTION, USE, PATENT RIGHTS AND SALES RIGHTS ARE EXPRESSLY RESERVED BY SAMTEC, INC. THIS DOCUMENT SHALL NOT BE DISCLOSED, IN WHOLE OR PART, TO ANY UNAUTHORIZED PERSON OR ENTITY NOR REPRODUCED, TRANSFERRED OR INCORPORATED IN ANY OTHER PROJECT IN ANY MANNER WITHOUT THE EXPRESS WRITTEN CONSENT OF SAMTEC, INC.



520 PARK EAST BLVD, NEW ALBANY, IN 47150  
 PHONE: 812-944-6733 FAX: 812-948-5047  
 e-Mail info@SAMTEC.com code 55322

DO NOT SCALE DRAWING

SHEET SCALE: 8:1

DESCRIPTION:  
 0.8MM UCC8 SOCKET ASSEMBLY

DWG. NO.  
**UCC8-XXX-X-XXX-X-X-A-XX**

BY: ETHAN C 02/24/2020 SHEET 3 OF 4

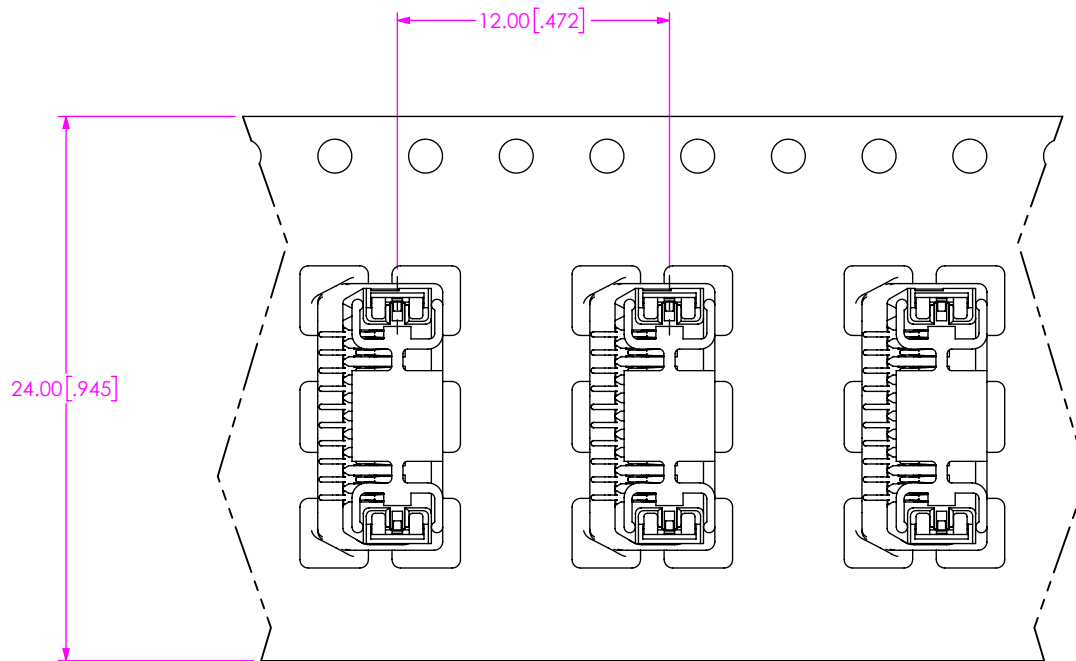

USER DIRECTION OF UN-REELING →  
POCKET NOT DETAILED

PACKAGING VIEW

• PROPRIETARY NOTE •  
THIS DOCUMENT CONTAINS CONFIDENTIAL AND PROPRIETARY INFORMATION AND ALL DESIGN, MANUFACTURING, REPRODUCTION, USE, PATENT RIGHTS AND SALES RIGHTS ARE EXPRESSLY RESERVED BY SAMTEC, INC. THIS DOCUMENT SHALL NOT BE DISCLOSED, IN WHOLE OR PART, TO ANY UNAUTHORIZED PERSON OR ENTITY NOR REPRODUCED, TRANSFERRED OR INCORPORATED IN ANY OTHER PROJECT IN ANY MANNER WITHOUT THE EXPRESS WRITTEN CONSENT OF SAMTEC, INC.



520 PARK EAST BLVD, NEW ALBANY, IN 47150  
PHONE: 812-944-6733 FAX: 812-948-5047  
e-Mail info@SAMTEC.com code 55322

DO NOT SCALE DRAWING

SHEET SCALE: 1:1

DESCRIPTION:  
0.8MM UCC8 SOCKET ASSEMBLY

DWG. NO.  
**UCC8-XXX-X-XXX-X-X-A-XX**

BY: ETHAN C 02/24/2020 SHEET 4 OF 4