

The YQB-R5F1057A-TB is a target board used for evaluating microcontroller operations using a Renesas E1 or E2 Lite on-chip debugging emulator / flash programmer.

1. RL78/G11 target board (YQB-R5F1057A-TB) features

- Incorporates RL78/G11 (R5F1057AANA).
- Equipped with universal area (2.54mm pitch).
- Supports both flash memory programming and on-chip debugging (using TOOL0 pin).
- Highly extendable; peripheral board connector used to access microcontroller pins.
- Lead-free (Pb-free) product.

2. Hardware Specifications

CPU R5F1057AANA	High Speed On-Chip Oscillator	48MHz to 1MHz
	Crystal Oscillator Connection	20MHz HC-49 (Not Fitted)
Embedded parts	CN2 : Peripheral board connector (2.54mm pitch), 24 pin socket (pads only).	
	CN1 : 14-pin connector (for E1 or E2 Lite connection)	
	Power LED : Red x 1 (POWERLED)	
	Test LED : Yellow x 2 (LED1 connected to P52, LED2 connected to P51).	
	Test Switch : SW1 (connected to P137 / INTPO).	
Operating voltage	Main clock : Internal HOCO up to 48MHz. Provision for 20MHz HC-49 crystal at position X1 (not fitted, also requiring links at R11, R12 and 18pF capacitors at C2, C3).	
	1.6V to 5.5V	

3. Dimensions and Parts Layout

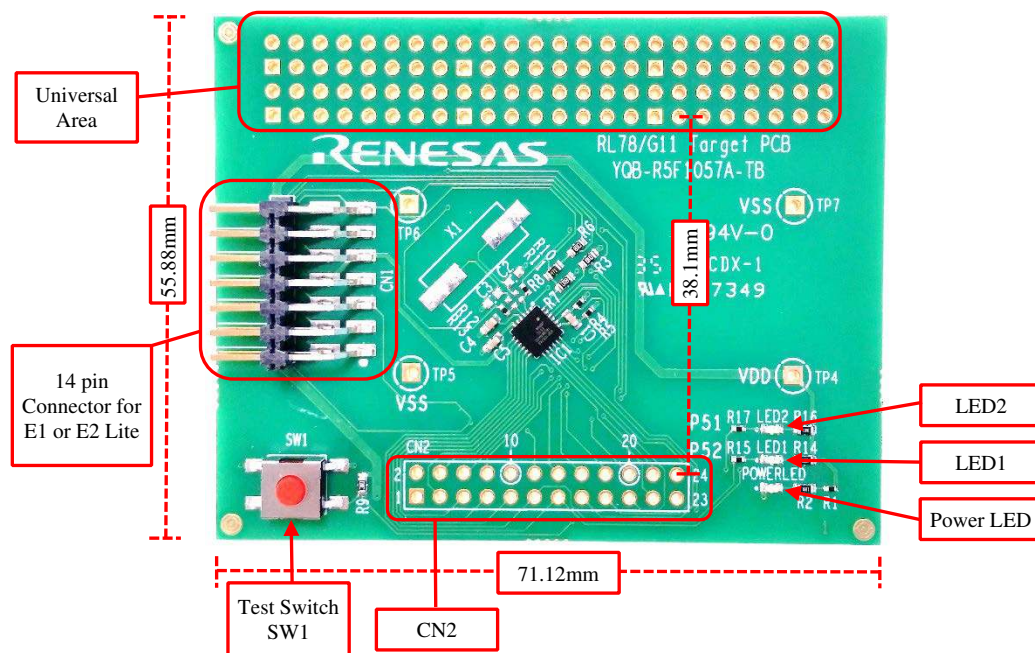

On-Board Link options: Removing the small (0402) 0Ω link resistors leaves open the relevant circuit (see schematic). To reconnect the circuit, short the link resistor pads by soldering or reconnecting link resistor. Link resistor positions are shown on the PCB silkscreen.

4. Product Support: Online technical support and information is available at <http://www.renesas.com>

5. Limitation of Warranty

The foregoing warranty does not cover damage caused by accidental misuse, abuse, neglect, misapplication or modification. No warranty of fitness for a particular purpose is offered. The user assumes the entire risk of using the product. Any liability of Renesas Electronics Europe is limited exclusively to the replacement of defective media, materials or workmanship.

RL78/G11 Target Board

Uncommitted array of pins

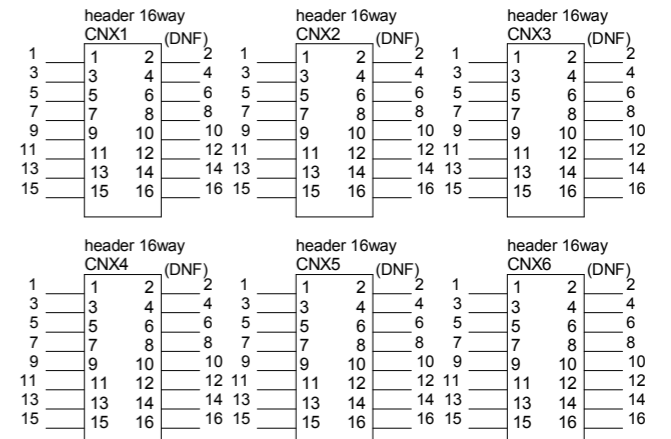

Power / Analogue / Vref Configuration

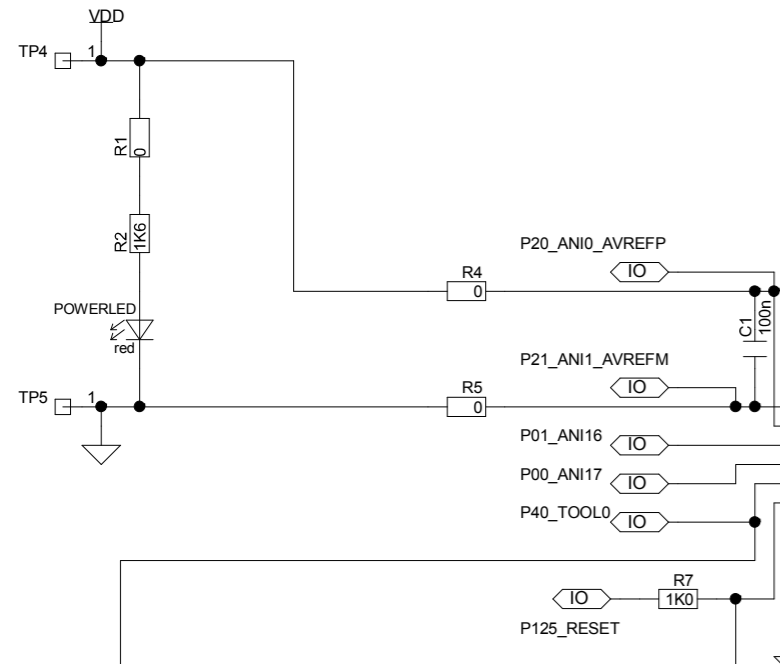

E1/E2 Lite Connection

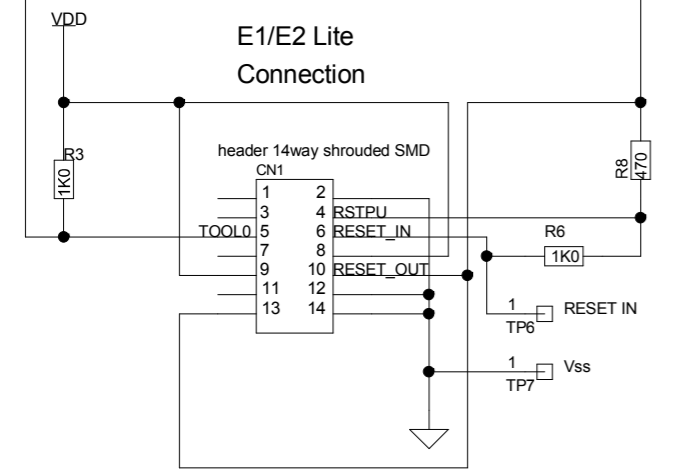

User Switch

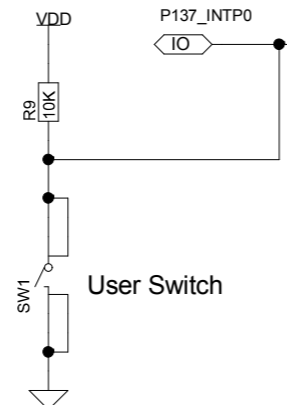

User LEDs

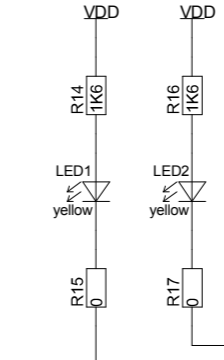

MCU Port Connections

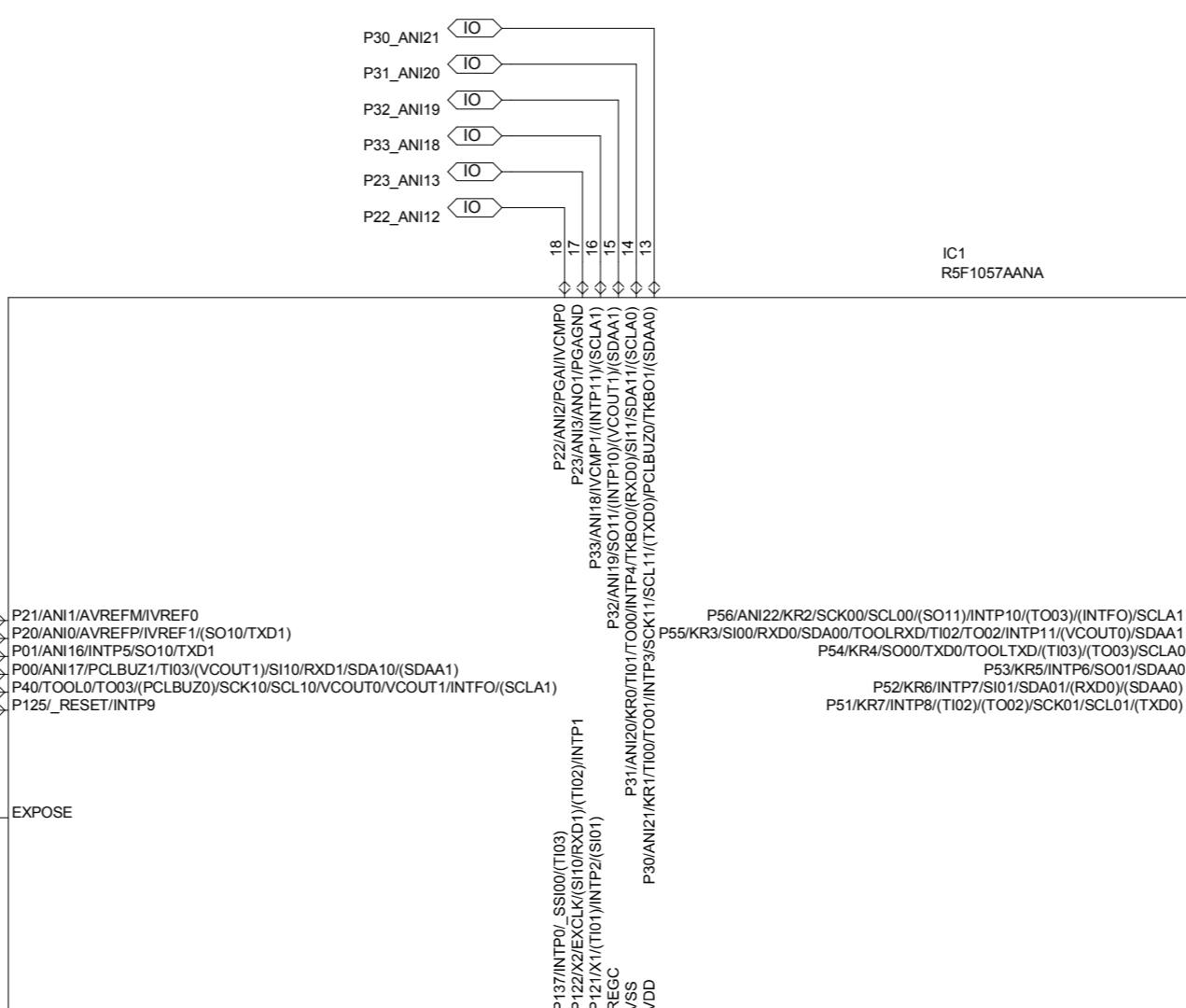
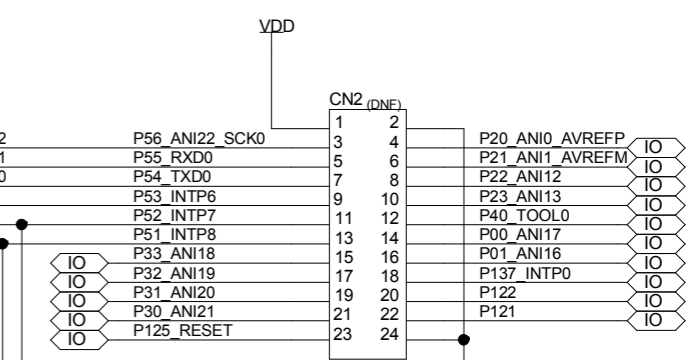

- 1 TP1 Fiducial_1mm
- 1 TP2 Fiducial_1mm
- 1 TP3 Fiducial_1mm

RENESAS Electronics Europe GmbH

Title: **RL78/G11 Target Board**

Size: **A3** Document Number: **R20UT3915EG0100**

Date: Tue Aug 09 15:40:13 2016 | PAGE 1 OF 2 | 1.00