



### TSOT-23



#### Pin Definition:

1. V<sub>CC</sub>
2. Output
3. GND

### Description

TSH248 Hall-effect sensor is a temperature stable, stress-resistant, micro-power switch. Superior high-temperature performance is made possible through a dynamic offset cancellation that utilizes chopper-stabilization. This method reduces the offset voltage normally caused by device over-molding, temperature dependencies and thermal stress.

TSH248 includes the following on a single silicon chip: voltage regulator, Hall voltage generator, small-signal amplifier, chopper stabilization, Schmitt trigger, open-drain output. Advanced CMOS wafer fabrication processing is used to take advantage of low-voltage requirements, component matching, very low input-offset errors and small component geometries.

### Features

- CMOS Hall IC Technology
- Solid-State Reliability
- Low power consumption for battery applications
- Operation voltage range from 2.5V~3.5V

### Ordering Information

Part No.	Package	Packing
TSH248CX RFG	TSOT-23	3kpcs / 7" Reel

**Note:** "G" denote for Halogen Free Product

### Application

- Solid state switch
- Lid close sensor for power supply devices
- Magnet proximity sensor for reed switch replacement in high duty cycle applications.
- Handheld Wireless Handset Awake Switch (Flip Cell/PHS Phone/Note Book/Flip Video Set)

### Absolute Maximum Ratings (T<sub>A</sub> = 25°C unless otherwise noted)

Characteristics	Limit	Value	Unit
Supply voltage	V <sub>CC</sub>	5	V
Output Voltage	V <sub>OUT</sub>	5	V
Reverse voltage	V <sub>CC/OUT</sub>	-0.3	V
Magnetic flux density		Unlimited	G
Output current	I <sub>OUT</sub>	2	mA
Operating Temperature Range	T <sub>OPR</sub>	-40 to +85	°C
Storage temperature range	T <sub>STG</sub>	-55 to +150	°C
Maximum Junction Temp	T <sub>J</sub>	150	°C
Thermal Resistance - Junction to Ambient	R <sub>θJA</sub>	543	°C/W
Thermal Resistance - Junction to Case	R <sub>θJC</sub>	410	°C/W
Package Power Dissipation	P <sub>D</sub>	230	mW

**Note:** Exceeding the absolute maximum ratings may cause permanent damage. Exposure to absolute maximum-rated conditions for extended periods may affect device reliability.

### Block Diagram

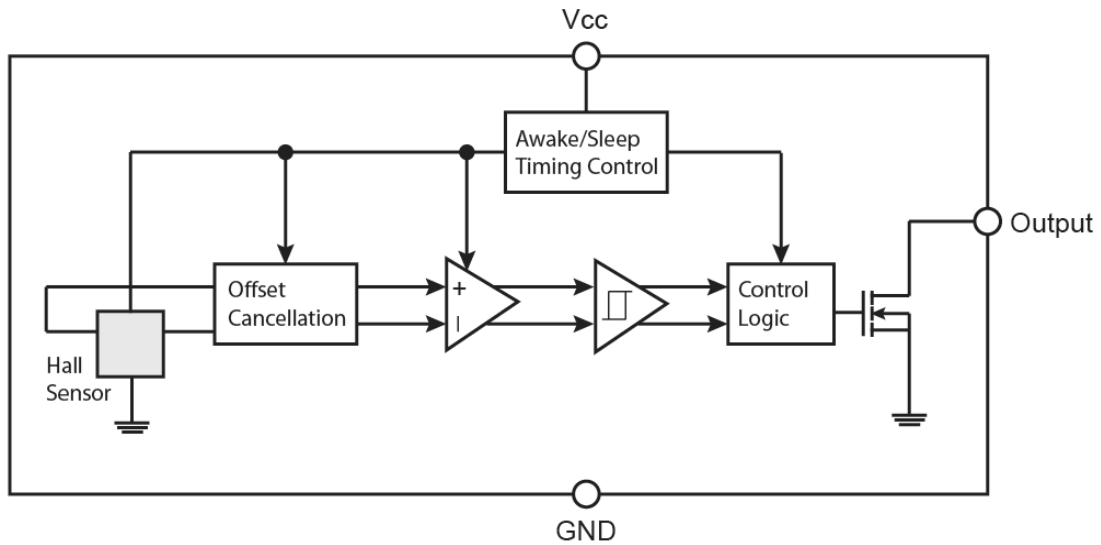

**Note:** Static sensitive device; please observe ESD precautions. Reverse V<sub>CC</sub> protection is not included. For reverse voltage protection, a 100Ω resistor in series with V<sub>CC</sub> is recommended.

### Typical Application Circuit

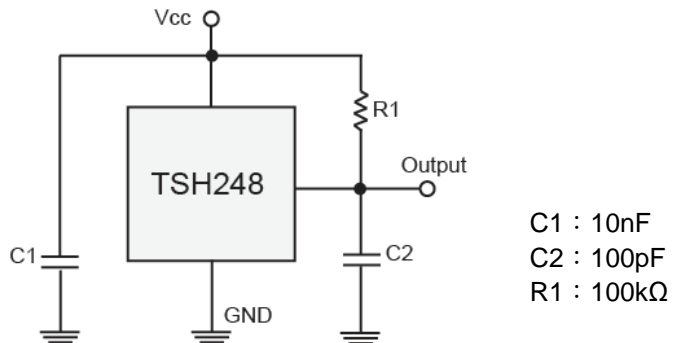

### Electrical Specifications (DC Operating Parameters: $T_A=+25^{\circ}\text{C}$ , $V_{CC}=3\text{V}$ )

Parameters	Test Conditions	Min	Typ	Max	Units
Supply Voltage	Operating	2.5	--	3.5	V
Supply Current	Awake State	--	2.5	4.0	mA
	Sleep State	--	8.0	12	$\mu\text{A}$
	Average	--	10	16	$\mu\text{A}$
Output Low Voltage	$I_{OUT}=1\text{mA}$	--	--	0.3	V
Output Leakage Current	Output off	--	--	1	$\mu\text{A}$
Awake Mode Time	Operating	--	70	--	$\mu\text{s}$
Sleep Mode Time	Operating	--	70	--	ms
Duty Cycle		--	0.1	--	%

### Magnetic Specifications

DC Operating Parameters  $T_A=25^{\circ}\text{C}$ ,  $V_{CC}=3.0\text{V}$

Parameter	Symbol	Test Conditions	Min.	Typ.	Max.	Units
Operating Point	$B_{OPS}$	N pole to branded side, $B > B_{OP}$ , $V_{OUT}$ On	6	--	60	G
	$B_{OPN}$	S pole to branded side, $B > B_{OP}$ , $V_{OUT}$ On	-60	--	-6	G
Release Point	$B_{RPS}$	N pole to branded side, $B < B_{RP}$ , $V_{OUT}$ Off	5	--	-59	G
	$B_{RPN}$	S pole to branded side, $B < B_{RP}$ , $V_{OUT}$ Off	-60	--	-5	G
Hysteresis	$B_{HYS}$	$ B_{OPx} - B_{RPx} $	--	7	--	G

Note: 1G (Gauss) = 0.1mT (millitesla)



### Output Behavior versus Magnetic Pole

DC Operating Parameters:  $T_A = -40$  to  $85^\circ\text{C}$ ,  $V_{CC} = 2.5\text{V} \sim 3.5\text{V}$

Parameter	Test condition	OUT
South pole	$B < B_{op}[(-60) \sim (-6)]$	Low
Null or weak magnetic field	$B = 0$ or $B < B_{RP}$	Open (Pull-up Voltage)
North pole	$B > B_{op}(60 \sim 6)$	Low

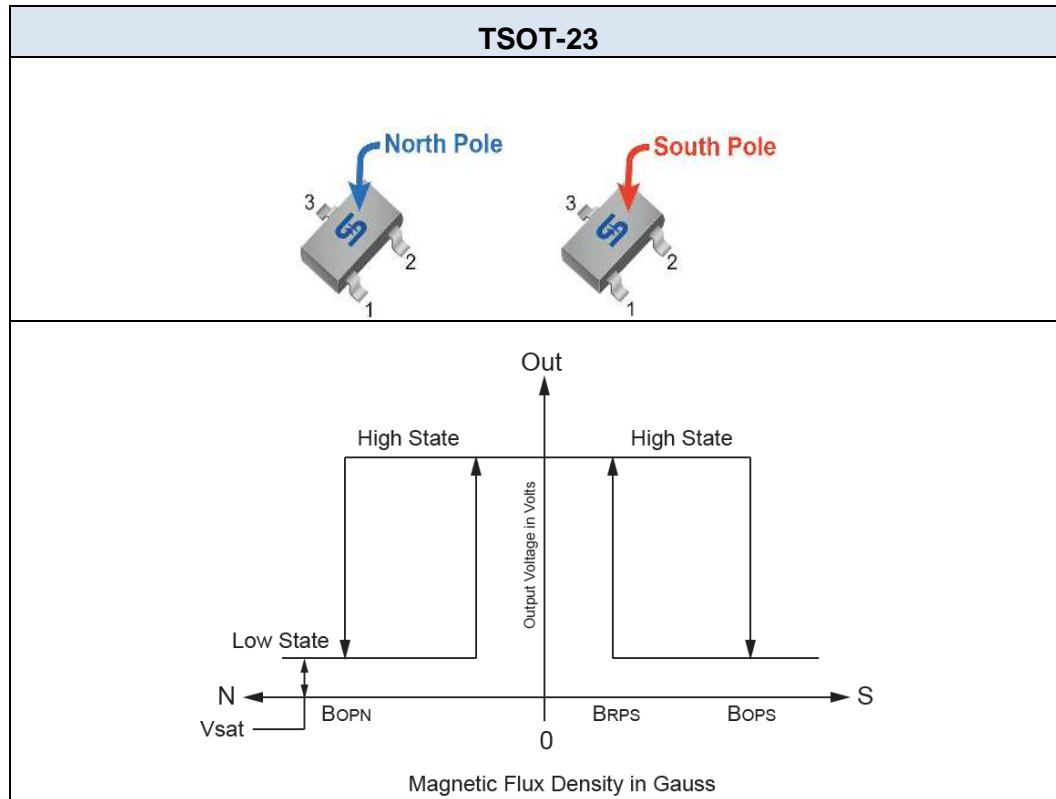

**Characteristic Performance**

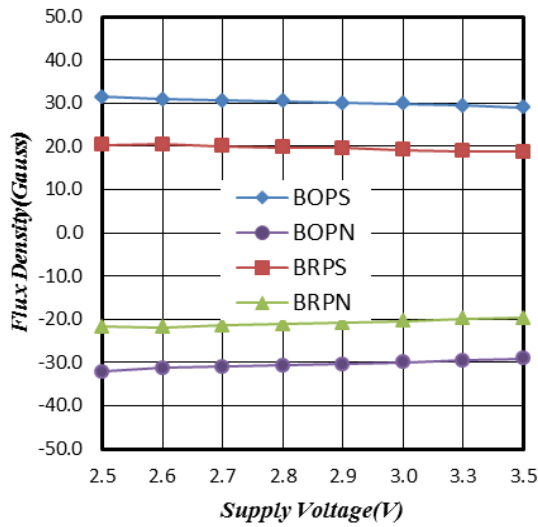

**Figure 1. Flux Density vs. Supply Voltage**

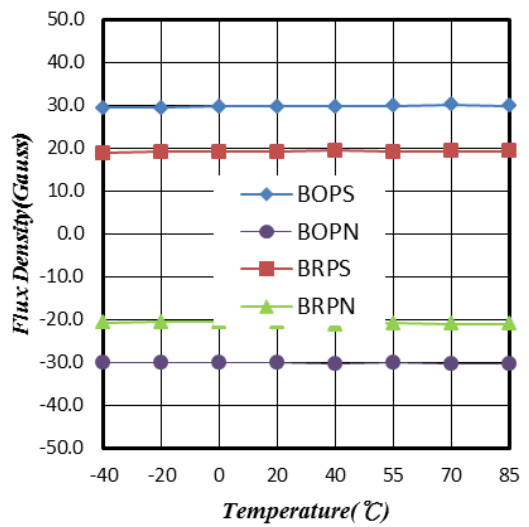

**Figure 2. Flux Density vs. Temperature**

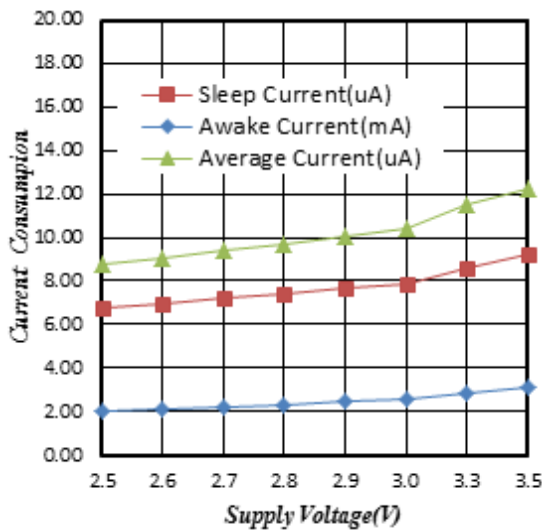

**Figure 3. Supply Current vs. Supply Voltage**

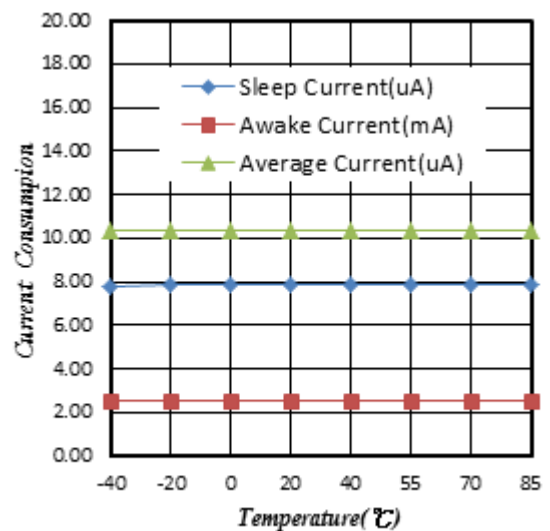

**Figure 4. Supply Current vs. Temperature**

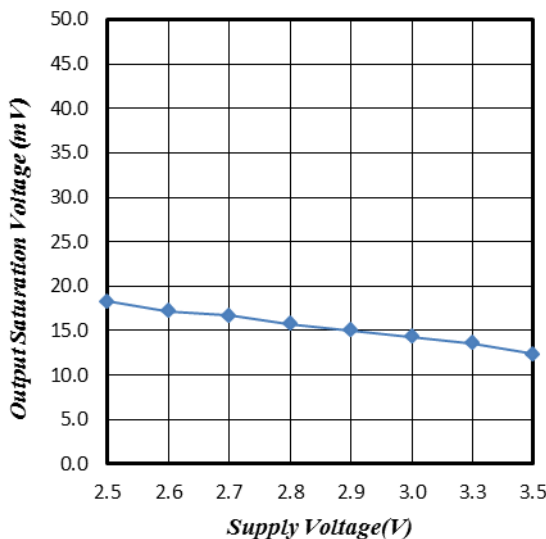

**Figure 5. Output Saturation Voltage vs. Supply Voltage**

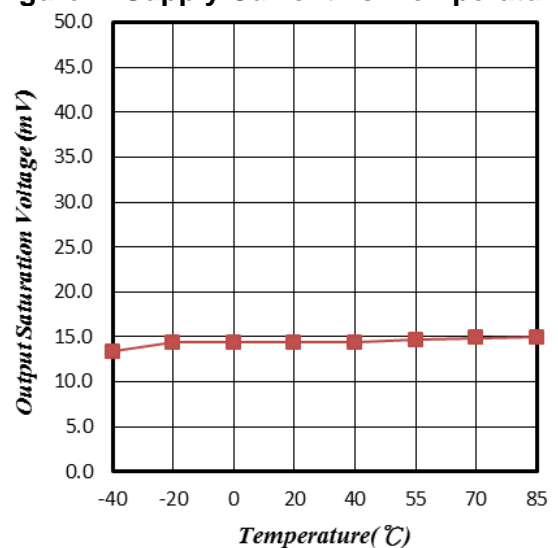

**Figure 6. Output Saturation Voltage vs. Temperature**



### Characteristic Performance

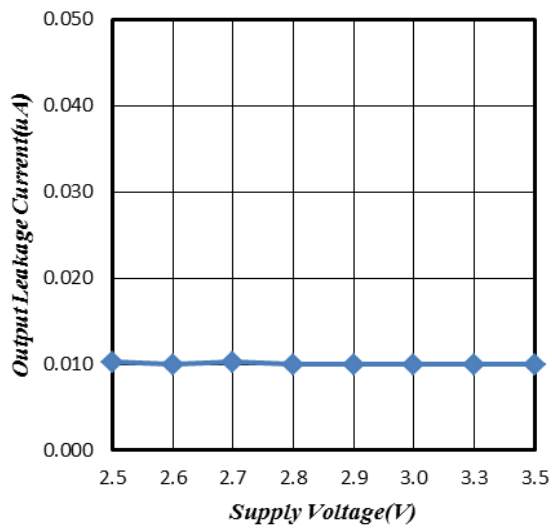

**Figure 7. Output Leakage Current vs. Supply Voltage**

**TSOT-23 Mechanical Drawing**

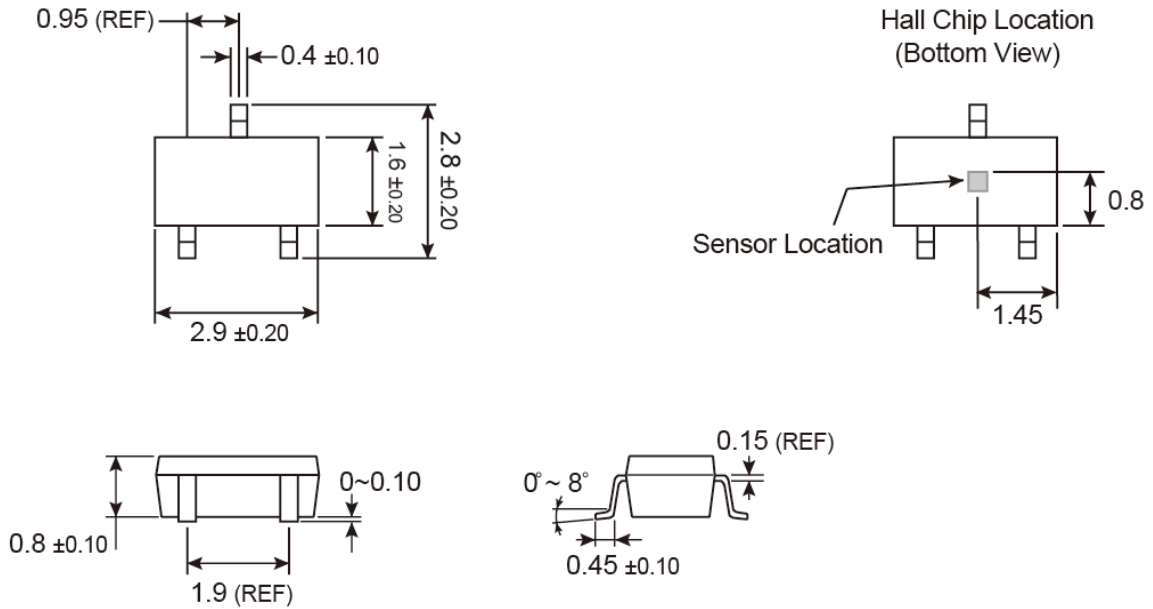

Unit: Millimeters

**Marking Diagram**

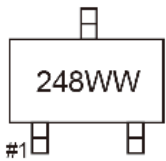

**248** = Device Code  
**WW** = Week Code Table

week	1	2	3	4	5	6	7	8	9	10	11	12	13
code	QA	QB	QC	QD	QE	QF	QG	QH	QI	QJ	QK	QL	QM
week	14	15	16	17	18	19	20	21	22	23	24	25	26
code	QN	QO	QP	QQ	QR	QS	QT	QU	QV	QW	QX	QY	QZ
week	27	28	29	30	31	32	33	34	35	36	37	38	39
code	RA	RB	RC	RD	RE	RF	RG	RH	RI	RJ	RK	RL	RM
week	40	41	42	43	44	45	46	47	48	49	50	51	52
code	RN	RO	RP	RQ	RR	RS	RT	RU	RV	RW	RX	RY	RZ

### Notice

Specifications of the products displayed herein are subject to change without notice. TSC or anyone on its behalf, assumes no responsibility or liability for any errors or inaccuracies.

Information contained herein is intended to provide a product description only. No license, express or implied, to any intellectual property rights is granted by this document. Except as provided in TSC's terms and conditions of sale for such products, TSC assumes no liability whatsoever, and disclaims any express or implied warranty, relating to sale and/or use of TSC products including liability or warranties relating to fitness for a particular purpose, merchantability, or infringement of any patent, copyright, or other intellectual property right.

The products shown herein are not designed for use in medical, life-saving, or life-sustaining applications. Customers using or selling these products for use in such applications do so at their own risk and agree to fully indemnify TSC for any damages resulting from such improper use or sale.