

SE-703 MANUAL

EARTH-LEAKAGE MONITOR

REVISION 12-B-092117

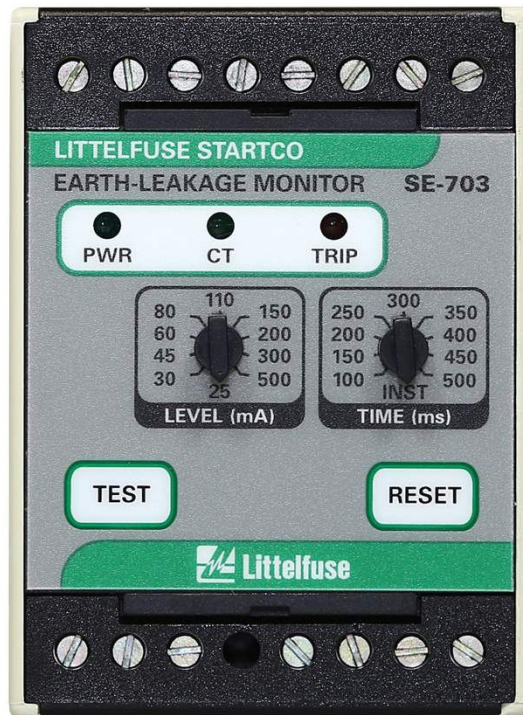

Copyright © 2017 by Littelfuse Startco
All rights reserved.

This page intentionally left blank.

TABLE OF CONTENTS

SECTION	PAGE
1 General	1
2 Operation	1
2.1 Configuration-Switch Settings	1
2.1.1 Relay Operating Mode.....	1
2.1.2 Filter Selection	1
2.2 Front-Panel Controls	1
2.2.1 Earth-Leakage Trip Level.....	1
2.2.2 Earth-Leakage Trip Time	1
2.2.3 Reset	1
2.2.4 Test	1
2.3 Front-Panel Indication	1
2.3.1 Power	1
2.3.2 Trip	1
2.3.3 CT Verification	1
2.4 Analog Output	5
2.5 Self Diagnostics	5
3 Installation	5
4 Technical Specifications	13
5 Ordering Information	15
6 Warranty	15
7 Earth-Fault Performance Test	15
Appendix A SE-703 Revision History	17

LIST OF FIGURES

FIGURE	PAGE
1A SE-703-0X-00 Outline and Mounting Details	2
1B SE-703-0X-02 Outline and Mounting Details	3
1C SE-703-0X Outline and Mounting Details	4
2 Typical Connection Diagrams	5
3 Typical Three-Phase Starter Connection	6
4 EFCT-1 Outline and Mounting Details	7
5 EFCT-2 Outline and Mounting Details	8
6 EFCT-26 Outline and Mounting Details.....	9
7 PMA-55 Panel-Mount Adapter	10
8 PMA-60 Panel-Mount Adapter	11
9 PGA-0500 Analog Percent Current Meter	12
10 TRIP Relays Maximum Switching Capacity	12
11 Earth-Fault-Test Circuit	16

LIST OF TABLES

TABLE	PAGE
1 Earth-Fault-Test Record	16

DISCLAIMER

Specifications are subject to change without notice. Littelfuse Startco is not liable for contingent or consequential damages, or for expenses sustained as a result of incorrect application, incorrect adjustment, or a malfunction.

This page intentionally left blank

1. GENERAL

The SE-703 is a microprocessor-based earth-leakage monitor for ac power supply systems incorporating earth-fault current limitation. The SE-703 has two isolated Form-C relays for use in independent control circuits. Additional features include LED trip and power indication, latching trips with front-panel and remote reset, trip memory, test button, self diagnostics, 0 to 5-V analog output, CT verification with LED indication, digital selector switches, and switch-selectable algorithms for fixed-frequency or variable-frequency applications.

Earth-leakage current is sensed by an EFCT-series core-balance earth-fault current transformer (CT). The trip level of the earth-leakage circuit is digital-switch selectable from 25 to 500 mA. Trip time is digital-switch selectable from INST (instantaneous) to 500 ms.

Ordering option SE-703-0x-00 is AS/NZS 2081:2011 compliant. Its output relays operate in the fail-safe mode for undervoltage applications.

Ordering option SE-703-0x-02 is AS/NZS 2081:2002 compliant. Its output relays operate in the fail-safe or non-fail-safe mode for undervoltage or shunt-trip applications.

2. OPERATION

2.1 CONFIGURATION-SWITCH SETTINGS

See Figs. 1A, 1B and 1C.

2.1.1 RELAY OPERATING MODE

The output relays for ordering option SE-703-0x-00 operate only in the fail-safe mode for undervoltage applications.

The output relays for ordering option SE-703-0x-02 operate in the fail-safe or non-fail-safe mode for undervoltage or shunt-trip applications.

Switch 1 is used to set the operating mode of the output relays (for SE-703-0x-02 only).

In the fail-safe mode, the output relays energize when the earth-leakage circuit is not tripped. Non-volatile memory retains the trip status of the SE-703. If tripped, and the supply voltage is cycled, the SE-703 will remain tripped, with the trip relay de-energized and the TRIP LED on, until reset.

In the non-fail-safe mode, the output relays energize when a ground-fault trip occurs. Trip status is not retained in non-volatile memory.

2.1.2 FILTER SELECTION

Switch 2 is used to select the filtering algorithm for a fixed-frequency (50/60 Hz) or variable-frequency application. The FIXED FREQUENCY setting uses a DFT filter that allows lower trip levels to be used by rejecting harmonics that can cause nuisance tripping.

The VARIABLE FREQUENCY setting uses a peak-detection algorithm with a wider bandwidth for fault detection in variable-frequency drive applications.

2.2 FRONT-PANEL CONTROLS

2.2.1 EARTH-LEAKAGE TRIP LEVEL

The LEVEL (mA) selector switch is used to set the earth-leakage trip level. For earth-leakage detection, the earth-leakage trip level must be substantially below the prospective earth-fault current. To avoid sympathetic tripping, the trip level must be above the charging current of the protected feeder.

2.2.2 EARTH-LEAKAGE TRIP TIME

The SE-703 has a definite-time trip characteristic. The TIME (ms) selector switch is used to set the earth-leakage trip time for coordination with upstream and downstream earth-fault devices. Coordination requires the same trip level for all earth-leakage devices in a system and the trip time to progressively increase upstream. The amount of equipment removed from the system will be a minimum if the first earth-leakage device to operate is the one immediately upstream from the fault.

2.2.3 RESET

A trip remains latched until the RESET button is pressed or the remote-reset terminals (6 and 7) are momentarily connected.

The reset circuit responds only to a momentary closure so that a jammed or shorted button will not prevent a trip. The front-panel RESET button is inoperative when the remote-reset terminals are connected.

2.2.4 TEST

The TEST button is used to test the earth-leakage circuit, the indication, and the output relays. When the TEST button is pressed for one second, a test signal is applied to the earth-leakage-detection circuit, the circuit will trip, the TRIP LED will light, and the output relays will operate.

2.3 FRONT-PANEL INDICATION

2.3.1 POWER

The green LED labelled PWR indicates presence of supply voltage.

2.3.2 TRIP

The red LED labelled TRIP indicates a trip. A solid red LED indicates an earth-leakage trip and a flashing LED indicates a trip initiated by a CT fault. Two fast flashes of the TRIP LED indicate a diagnostic trip. See Section 2.5.

2.3.3 CT VERIFICATION

The green LED labelled CT indicates that an EFCT-series sensor is connected.

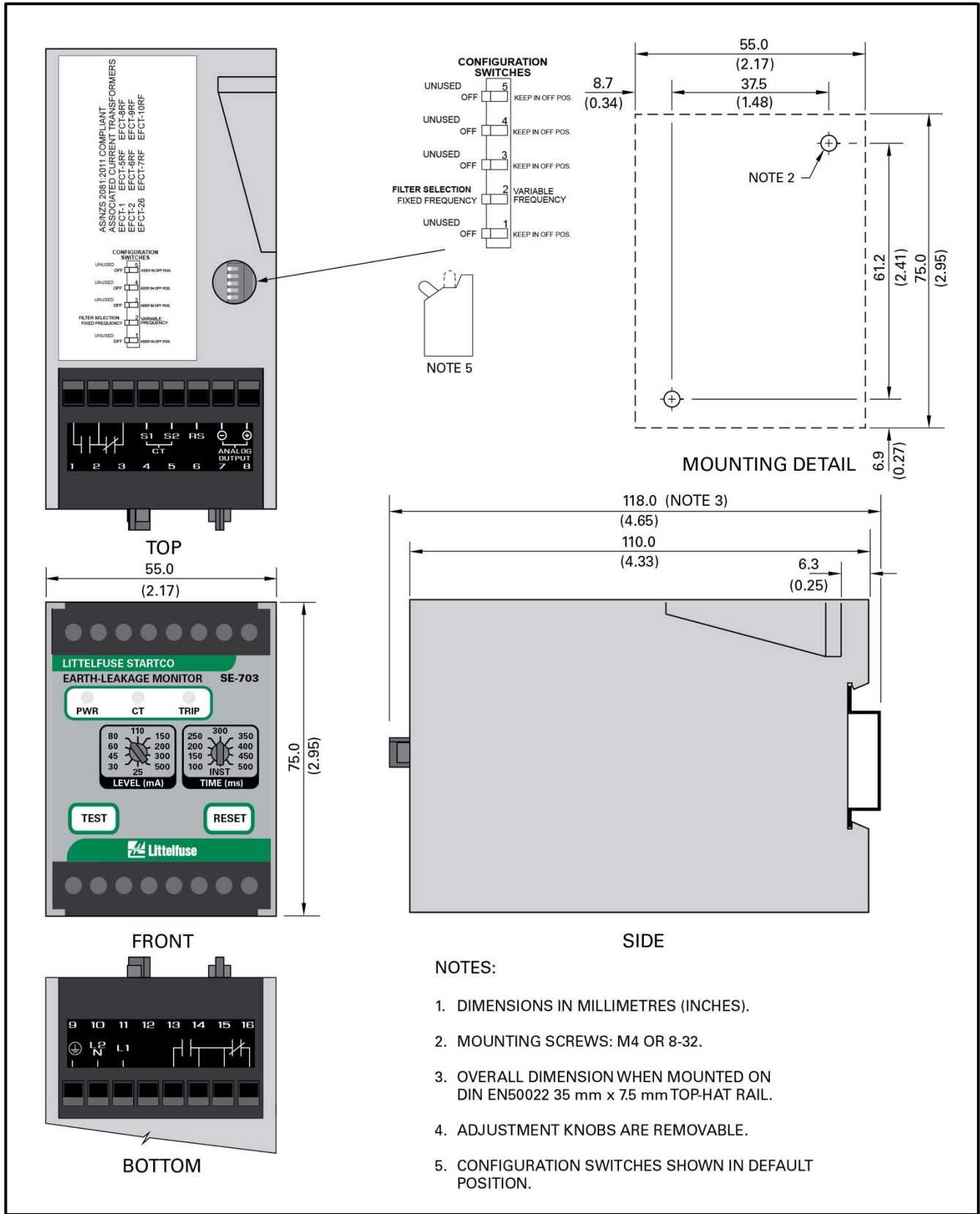

FIGURE 1A. SE-703-0X-00 Outline and Mounting Details.

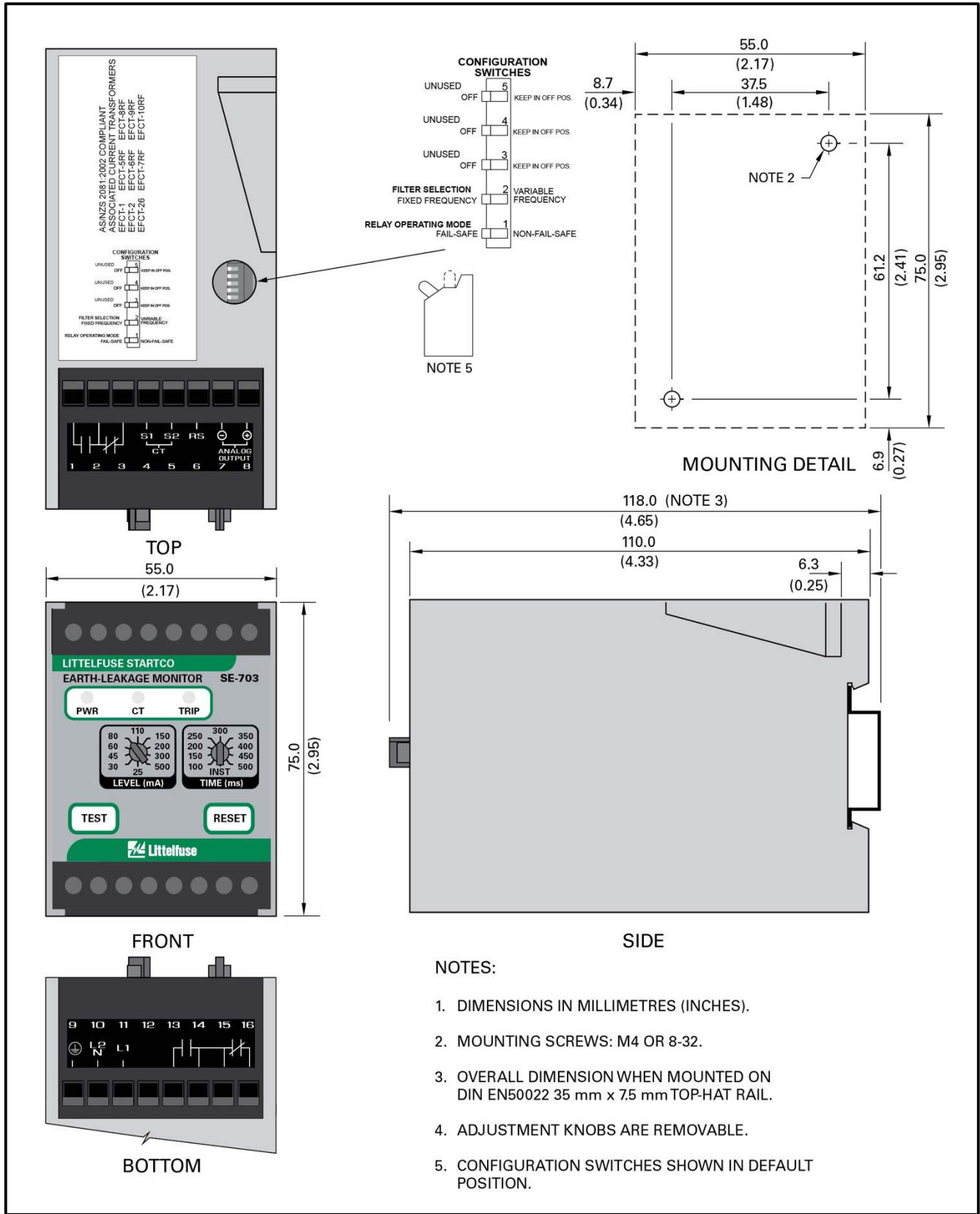

FIGURE 1B. SE-703-0X-02 Outline and Mounting Details.

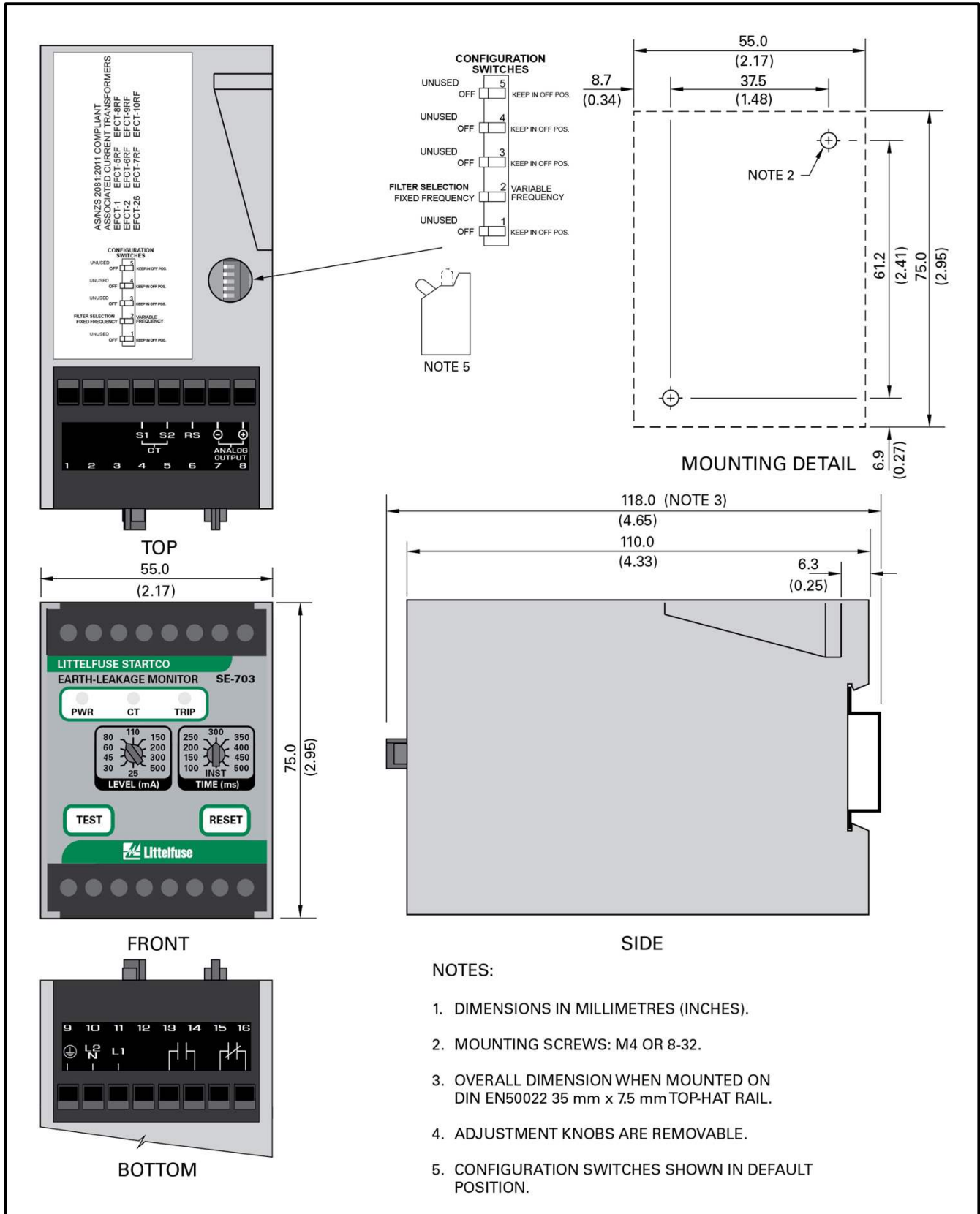

FIGURE 1C. SE-703-0X Outline and Mounting Details.

2.4 ANALOG OUTPUT

The non-isolated, 0- to 5-V analog output indicates earth-leakage current sensed by the EFCT. The output is 5 V when earth-leakage current is 500 mA. Use a PGA-0500 Analog Percent Current Meter with the PGA-05CV Voltage Converter to indicate earth-leakage current. See Figs. 2, 3, and 9.

2.5 SELF DIAGNOSTICS

A diagnostic trip is indicated by two fast flashes of the TRIP LED. It can be caused by a problem detected by an incorrect reading from non-volatile memory. Press RESET or cycle supply voltage. If the problem persists, consult Littelfuse Startco.

3. INSTALLATION

NOTE: Mounting, terminal-block connections, and wiring must conform to applicable local electrical codes. Check all applicable codes prior to installation

This earth-leakage monitoring system consists of an SE-703 Earth-Leakage Monitor and an EFCT-series current sensor connected as shown in Figs. 2 and 3.

An SE-703 can be surface or DIN-rail mounted. See Figs. 1A, 1B and 1C. Panel mounting requires a PMA-55 or PMA-60 Panel-Mount Adapter. See Figs. 7 and 8. A PMA-60 meets the AS/NZS 2081:2011 IP53 requirement and includes tamper-resistant security screws to prevent changes to the SE-703 front-panel settings.

Use terminal 11 (L1) as the line terminal on ac systems or the positive terminal on dc systems. Use terminal 10 (L2/N) as the neutral terminal on ac systems or the negative terminal on dc systems. Connect terminal 9 (⊕) to earth.

Pass the phase conductors through the EFCT window and position them in the centre of the opening—for 4-wire and single-phase systems, also pass the neutral conductor through the EFCT window, as shown in Figs. 2 and 3. Do not pass earth conductors through the EFCT window. In applications that require shields or drain wires to pass through the EFCT window, return them through the EFCT window before connecting them to earth. Connect the EFCT current sensor to terminals 4 and 5, connect the shield to terminal 5, and earth terminal 5. See Figs. 4, 5, and 6 for EFCT-series current-sensor dimensional drawings.

Remove the connection to terminal 9 for dielectric-strength testing.

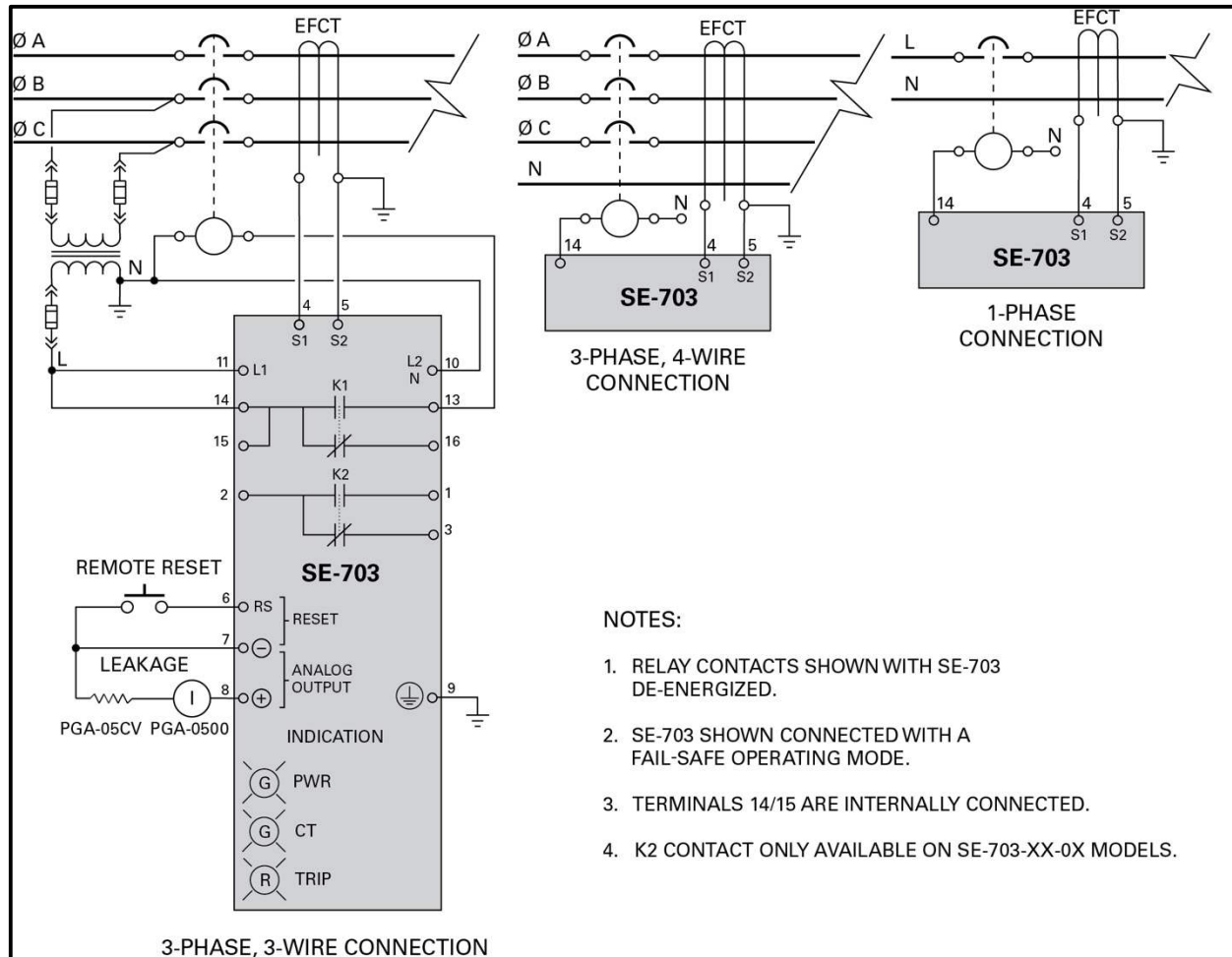

FIGURE 2. Typical Connection Diagrams.

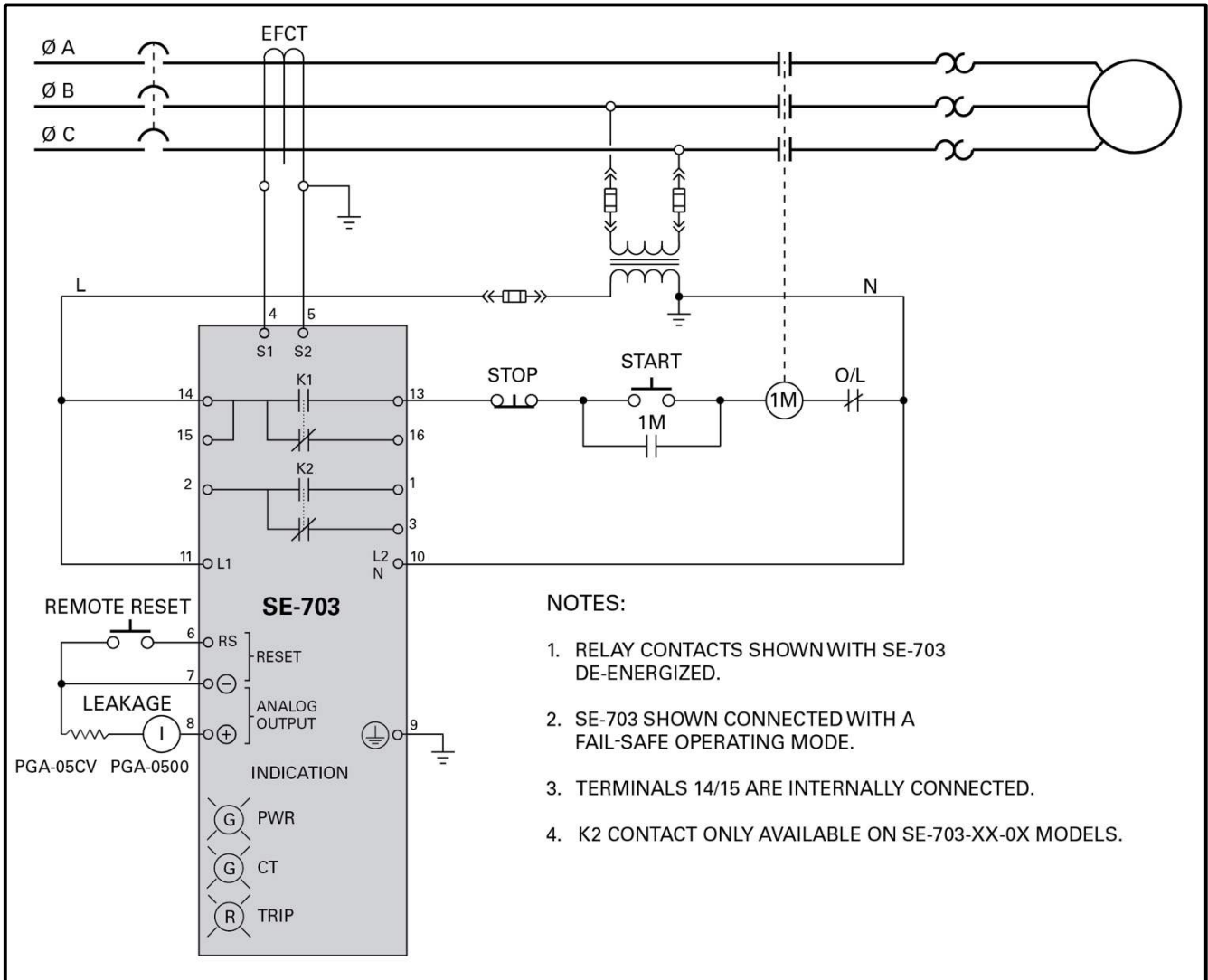

FIGURE 3. Typical Three-Phase Starter Connection.

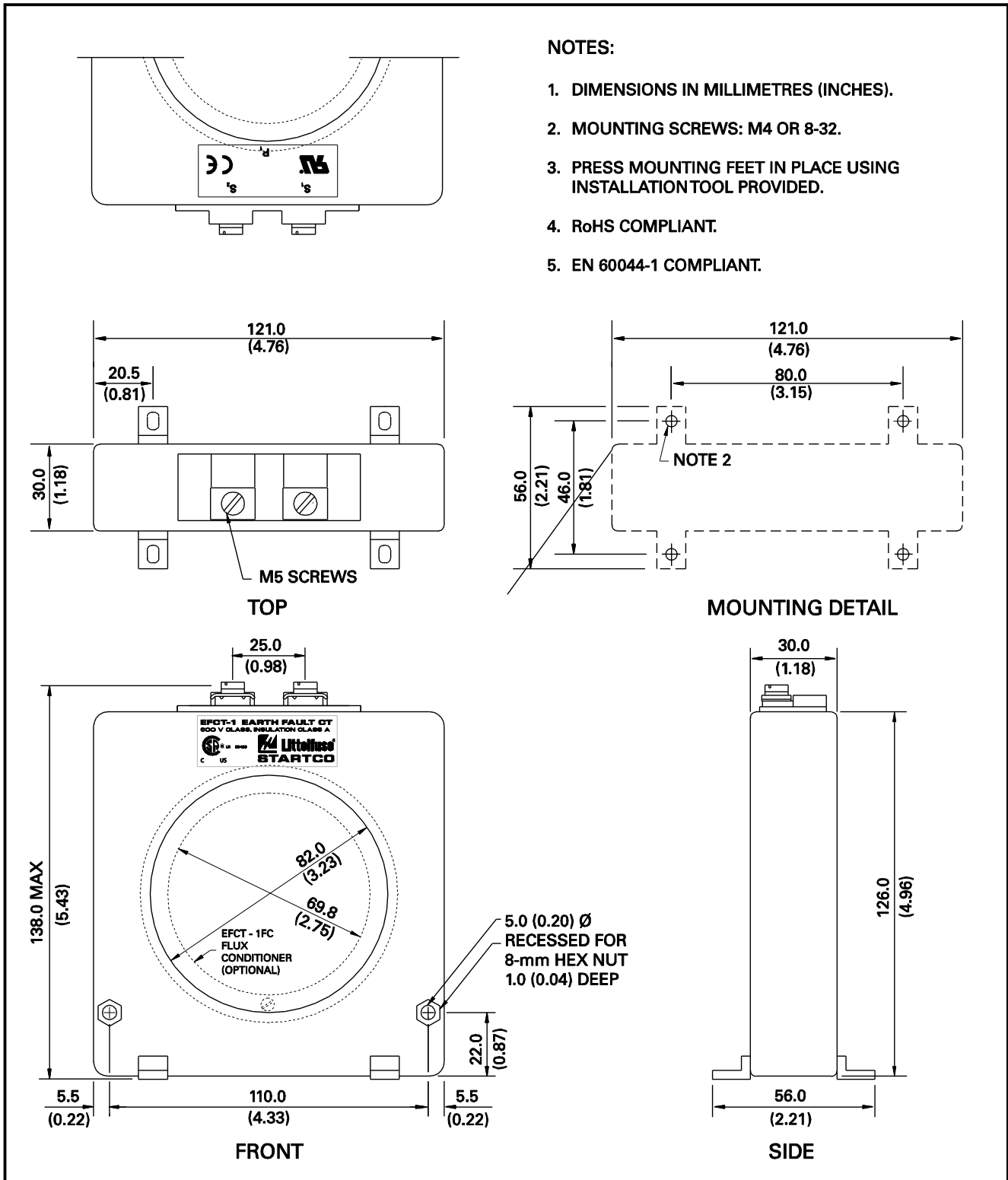

FIGURE 4. EFCT-1 Outline and Mounting Details.

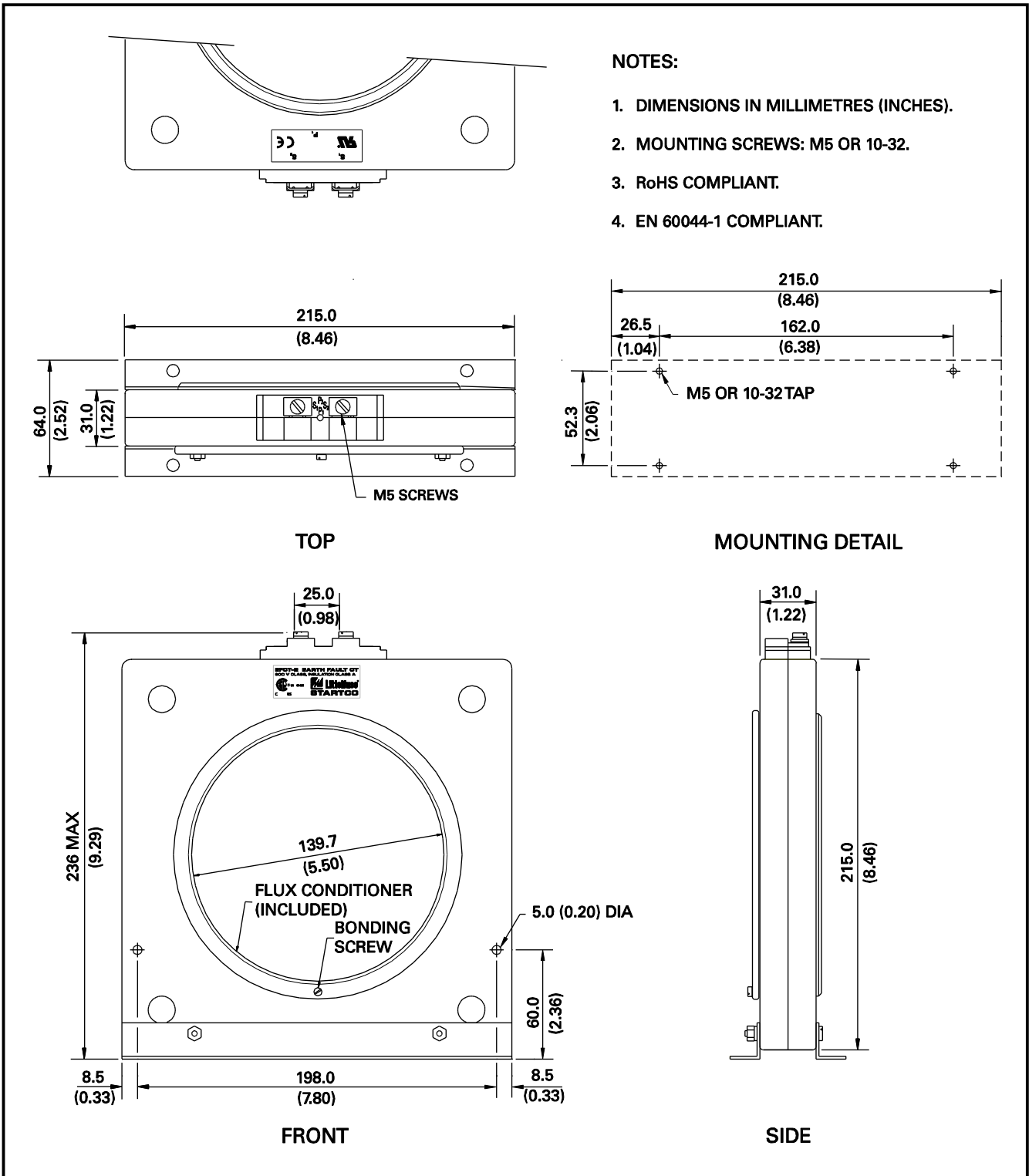

FIGURE 5. EFCT-2 Outline and Mounting Details.

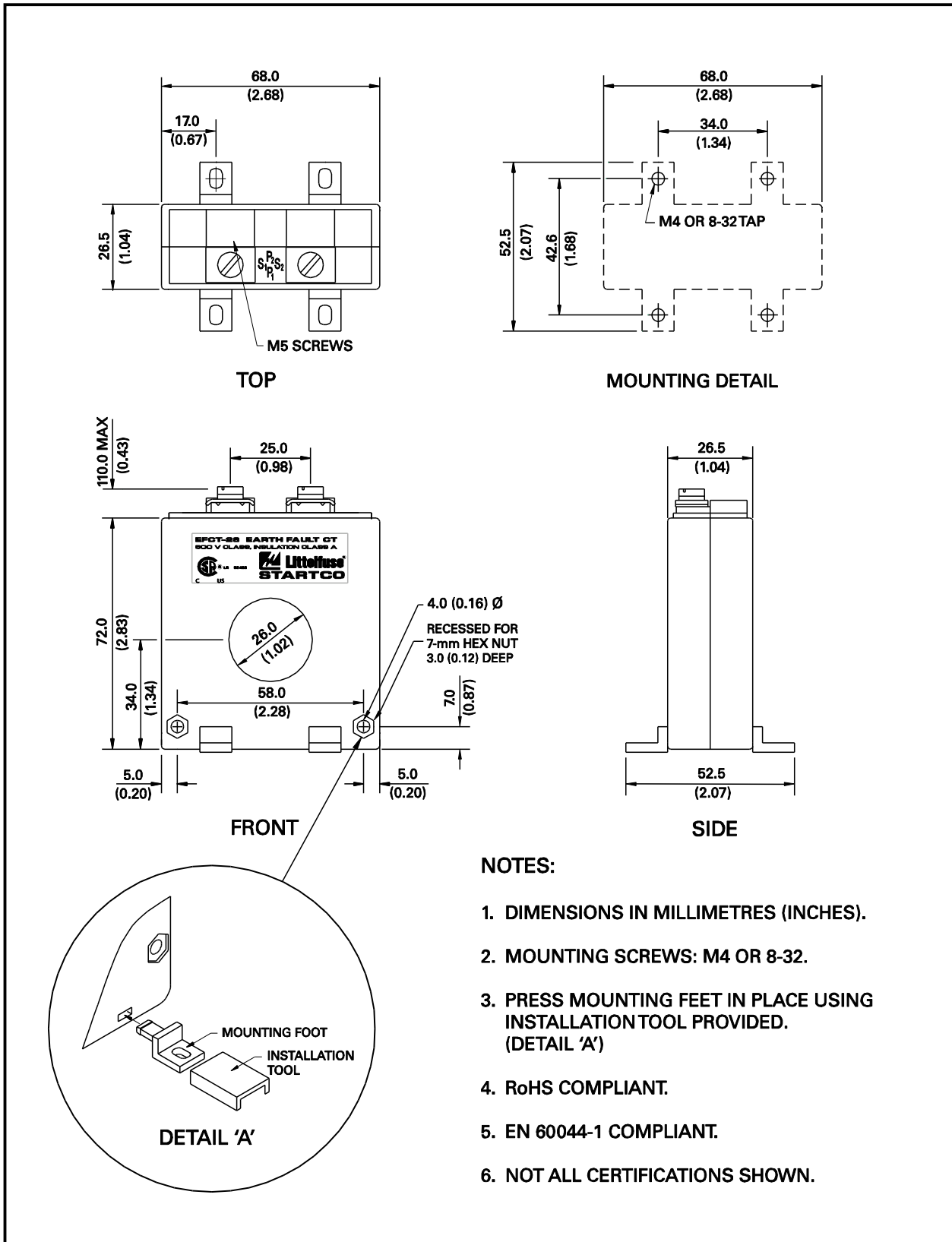

FIGURE 6. EFCT-26 Outline and Mounting Details.

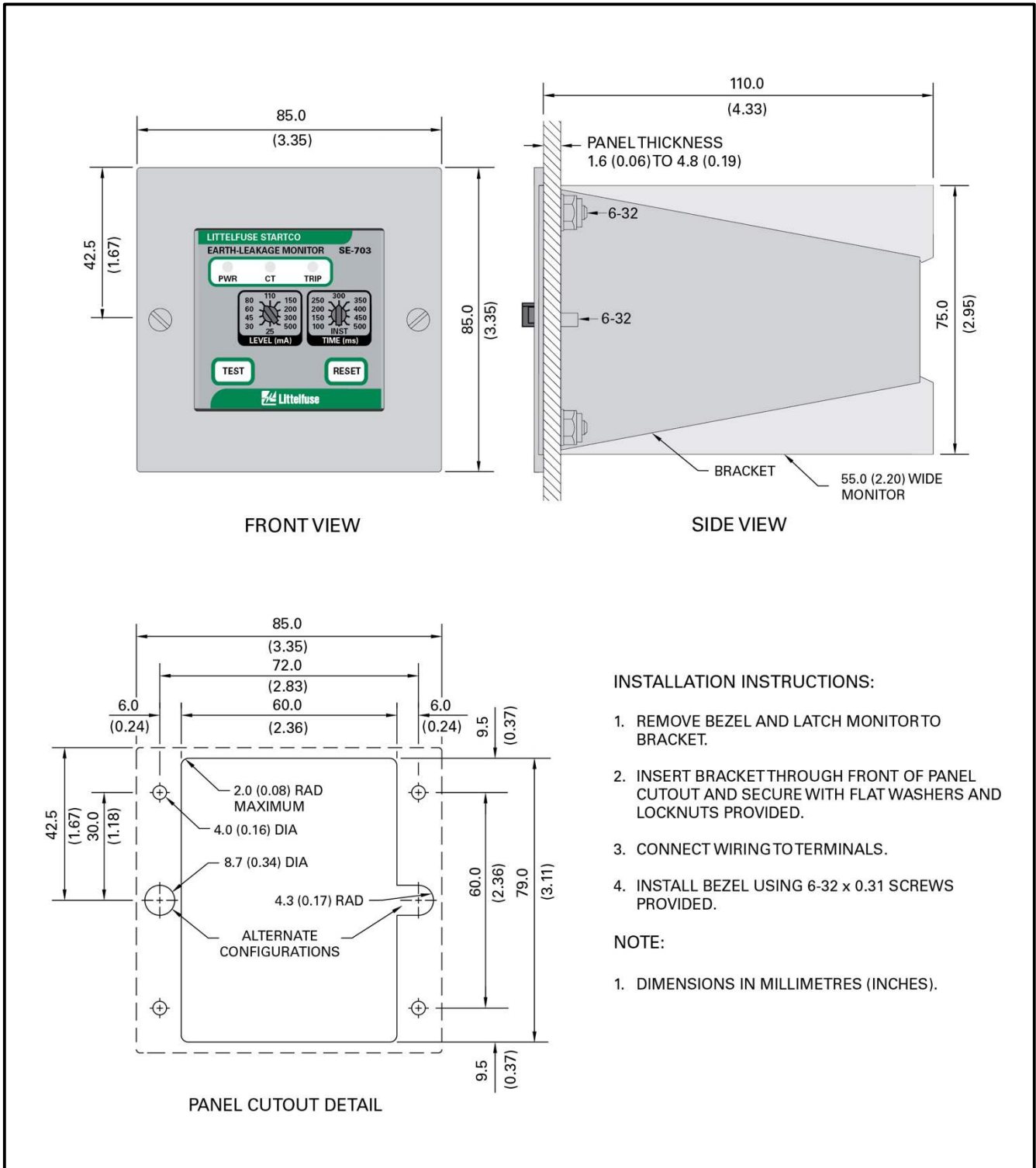

FIGURE 7. PMA-55 Panel-Mount Adapter.

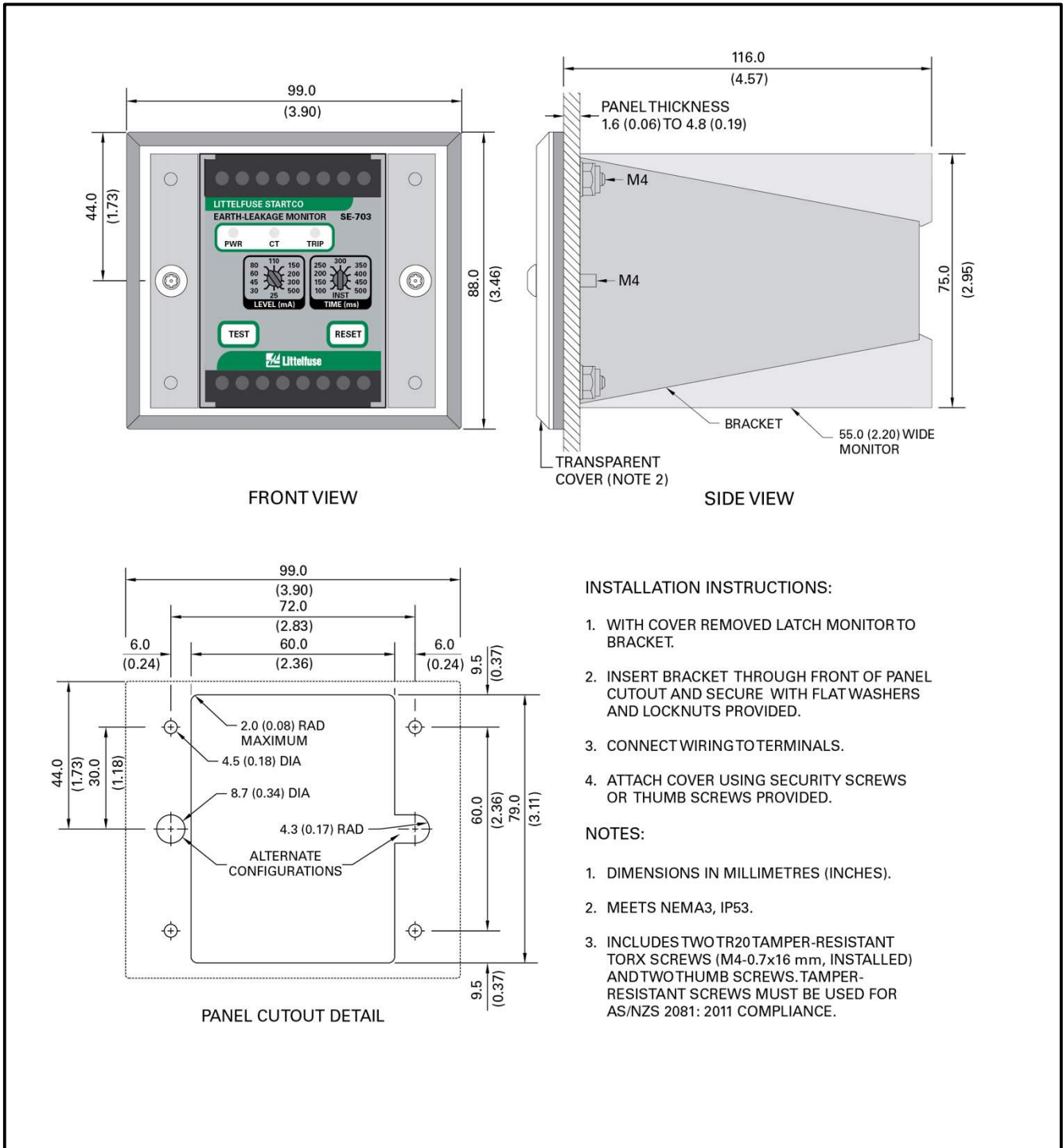

FIGURE 8. PMA-60 Panel-Mount Adapter.

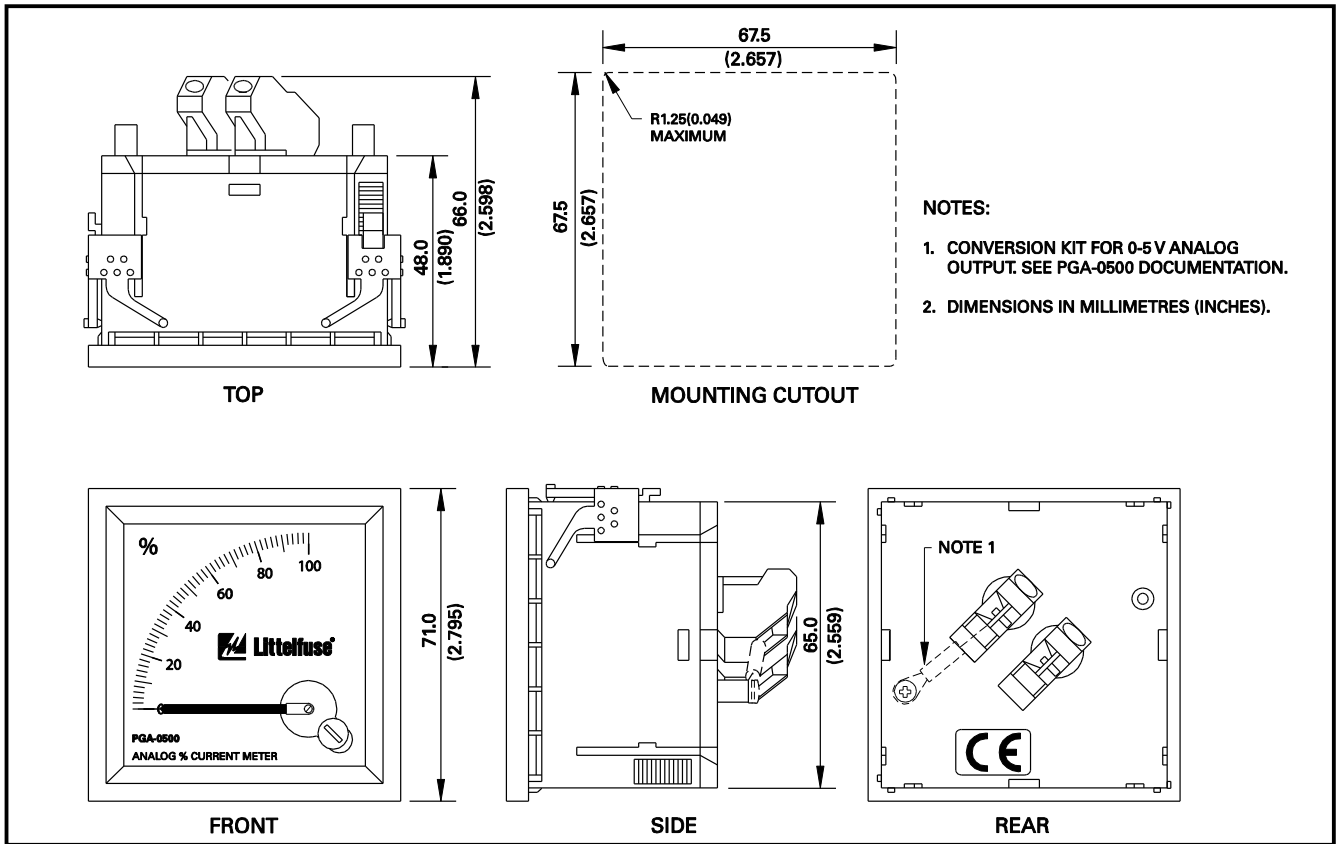

FIGURE 9. PGA-0500 Analog Percent Current Meter.

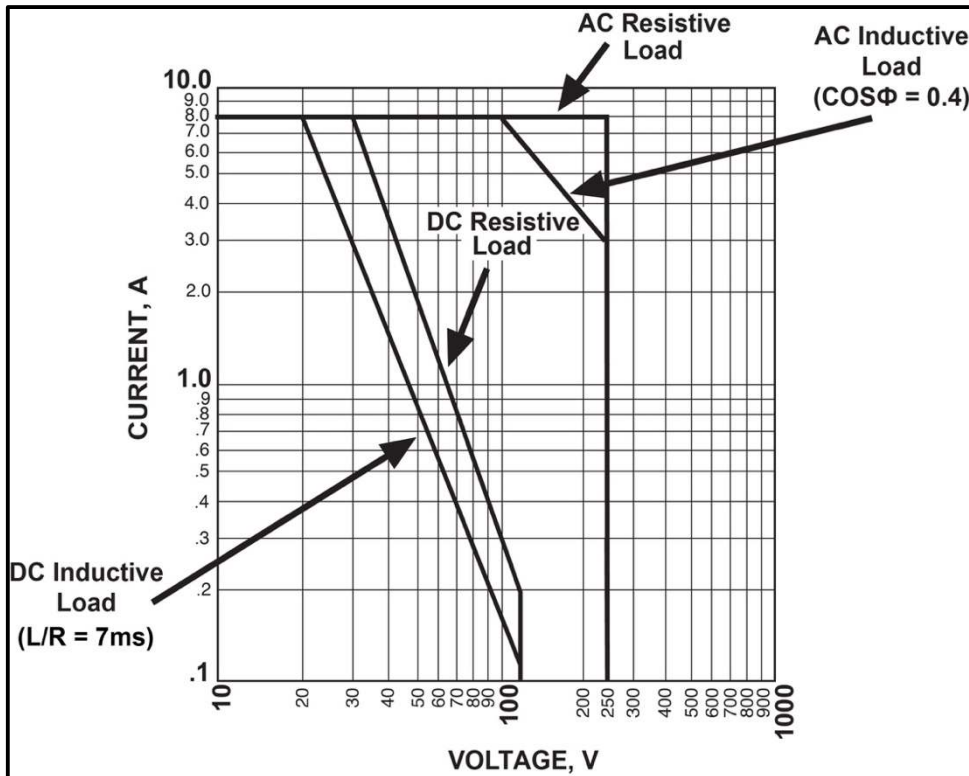

FIGURE 10. TRIP Relays Maximum Switching Capacity.

4. TECHNICAL SPECIFICATIONS

Supply:

0U Option	5 VA, 120 to 240 Vac, (+20, -55%), 50/60 Hz, 2 W, 100 to 240 Vdc, (+20, - 25%)
0D Option	2 W, 12 to 30 Vdc, (+20, -25%)
0T Option	2 W, 40 to 55 Vdc, (+20, -25%)
03 Option	2.5 VA, 24 Vac, (+15%, -40%), 50/60 Hz

Trip-Level Settings.....	25, 30, 45, 60, 80, 110, 150, 200, 300, and 500 mA
--------------------------	--

Trip-Time Settings	INST, 100, 150, 200, 250, 300, 350, 400, 450, and 500 ms
--------------------------	--

Accuracies: ⁽¹⁾

Trip Level: ⁽²⁾

SE-703-0x.....	10% of setting
SE-703-0x-00	10% of setting
SE-703-0x-02	+0, -20% of setting

Trip Time ⁽³⁾	+0, -20% of setting
INST Setting	< 50 ms

Discrimination Time	≥ 75% of trip time setting, Minimum off time 25 ms
---------------------------	---

Input:

Algorithms	DFT Digital or Peak
DFT 3 dB	
Frequency Resp.....	32 to 86 Hz
Peak 3 dB	
Frequency Resp.....	20 to 420 Hz
CT	EFCT Series
Thermal Withstand:	
Continuous	25 A Earth-Fault Current
1-Second	400 A Earth-Fault Current

Analog Output:

Range	0 to 5 V, 10 mV per mA
Output Impedance	220 Ω

Reset	Front-Panel Button and Remote, N.O. Contact
-------------	--

Functional Test.....	Front-Panel Button
----------------------	--------------------

Output Relay 1 and Relay 2:

Contact Configuration

SE-703-0x.....	Relay 1 only, Isolated N.O. and N.C.
SE-703-0x-00, SE-703-0x-02	N.O. and N.C. (Form-C), Isolated

Operating Mode

SE-703-0x.....	Fail-Safe
SE-703-0x-00	Fail-Safe
SE-703-0x-02	Fail-Safe or Non-Fail-Safe

CSA/UL Contact Rating	8 A General Use, 250 Vac, 8 A Resistive, 30 Vdc 0.25 HP, 120/240 Vac
-----------------------------	---

Supplemental Contact Ratings:

Carry Current.....	8 A, maximum
Break:	
30 Vdc	240 W Resistive, 170 W Inductive (L/R = 7 ms)
120 Vdc	24 W Resistive, 17 W Inductive (L/R = 7 ms)
ac	2,000 VA Resistive, 875 VA Inductive (PF = 0.4)
Subject to maximums of 8 A and 250 Vac/30 Vdc or 200 mA at 120 Vdc	

Trip Mode	Latching
Terminals	Wire Clamping, 24 to 12 AWG (0.2 to 2.5 mm ²) conductors
Tightening Torque.....	0.40 N·m (3.54 lbf·in)





Dimensions:

Height	75 mm (3.0")
Width	55 mm (2.2")
Depth	113 mm (4.5")

Shipping Weight	0.45 kg (1 lb)
-----------------------	----------------

Environment:

Operating Temperature:	
Altitude:	
≤ 1,000 m (3,281')	-40 to 60°C (-40 to 140°F)
3,000 m (9,843')	-40 to 55°C (-40 to 131°F)
5,000 m (16,404')	-40 to 50°C (-40 to 122°F)
Storage Temperature	-55 to 80°C (-67 to 160°F)

Humidity	93% Non-Condensing	Magnetic Field Immunity.....	IEC 61000-4-8 50 Hz and 60 Hz , 30 A/m and 300 A/m
Altitude	5,000 m (16,404') maximum	Voltage Interruption	IEC 61000-4-11, IEC 61000-4-29, 0% for 5, 10, 20, 50, 100 & 200 ms 3x each
Overvoltage Category	II	Power Frequency	IEC 61000-4-16 Zone A: differential mode 150 Vrms Zone A: common mode 300 Vrms
Pollution Degree.....	2	1 MHz Burst.....	IEC 61000-4-18 ± 1 kV differential mode (line-to-line) ± 2.5 kV common mode
Enclosure Rating	IP20	RFI Compliance	FCC Part 15, Subpart B, Class A – Unintentional Radiators
PWB Conformal Coating.....	MIL-1-46058 qualified UL QMJU2 recognized	Compliance:	
Surge Withstand	ANSI/IEEE 37.90.1-1989 (Oscillatory and Fast Transient)	Option SE-703-0x.....	AS/NZS 2081:2011
Vibration.....	EN60255-21-1 (Vibration, Shock, and Seismic) EN60255-21-2 (Shock and Bump)	Option SE-703-0x-00	AS/NZS 2081:2011
EMC Tests:		Option SE-703-0x-02	AS/NZS 2081:2002
Verification tested in accordance with IEC 60255-26:2013		Certification	CSA, Canada and USA
Radiated and Conducted			UL Listed
Emissions	CISPR 11:2009, CISPR 22:2008, EN55022:2010 Class A		Ground Fault Sensing and Relaying Equipment 4FX9 E340889
Current Harmonics and		Australia	
Voltage Fluctuation	IEC 61000-3-2 and IEC 61000-3-3 Class A		FCC
Electrostatic Discharge	IEC 61000-4-2 ± 6 kV contact discharge (direct and indirect) ± 8 kV air discharge		CE, European Union
Radiated RF Immunity	IEC 61000-4-3 10 V/m, 80-1000 MHz, 80% AM (1 kHz) 10 V/m, 900 MHz, 200 Hz pulse modulated		
Fast Transient.....	IEC 61000-4-4 ±4 kV on AC mains and I/O lines	CSA C22.2 No.14 Industrial Control Equipment	
Surge Immunity.....	IEC 61000-4-5 Zone B ± 1 kV differential mode ± 2 kV common mode	UL 508 Industrial Control Equipment	
Conducted RF Immunity.....	IEC 61000-4-6 10 V, 0.15-80 MHz, 80% AM (1 kHz)	UL 1053 Ground Fault Sensing and Relaying Equipment	

NOTES:

- (1) At 50 or 60 Hz.
- (2) Maximum lead resistance of 2 Ω.
- (3) Trip Time at 1.5 x trip-level setting.

5. ORDERING INFORMATION

SE-703-0	<div style="border: 1px solid black; width: 15px; height: 15px; display: inline-block; margin-right: 5px;"></div> <div style="border: 1px solid black; width: 15px; height: 15px; display: inline-block; margin-left: 5px;"></div>	<p>Options:</p> <p>0 – AS/NZS 2081:2011 (Fail-Safe Mode)</p> <p>2 – AS/NZS 2081:2002 (Fail-Safe and Non-Fail-Safe Modes)</p> <p>Supply:</p> <p>3 – 24-Vac Supply</p> <p>U – Universal 120/240-Vac/Vdc Supply</p> <p>D – 12/24-Vdc Supply</p> <p>T – 48-Vdc Supply</p>
----------	--	---

EFCT-1	Earth-Fault Current Sensor, 82 mm (3.2") window
EFCT-2	Earth-Fault Current Sensor, with Flux Conditioner 139 mm (5.5") window
EFCT-26	Earth-Fault Current Sensor, 26 mm (1.0") window
EFCT-1FC	Flux Conditioner, 70 mm (2.7") window
PGA-0500	Analog Percent Current Meter (PGA-05CV Included)
PMA-55	Panel-Mount Adapter, NEMA 1
PMA-60	Panel-Mount Adapter, NEMA 3, IP53. Includes two TR20 tamper- resistant Torx screws ⁽¹⁾ and two thumb screws.
AC700-HW-00	TR20 tamper-resistant Torx, 0.25" insert bit
AC700-HW-01	TR20 tamper-resistant Torx driver
PMA-3	Adapter Plate, GEC/MCGG
PMA-6	Adapter Plate, FPL-GFRM
PMA-15	Adapter Plate, MGFR
Consult factory for custom mounting adapters.	

Startco Pty. Australian Current Sensors

EFCT-5RF	Earth-Fault Current Sensor, 60 mm (2.4") window
EFCT-6RF	Earth-Fault Current Sensor, 85 mm (3.3") window
EFCT-7RF	Earth-Fault Current Sensor, 112 mm (4.4") window
EFCT-8RF	Earth-Fault Current Sensor, 140 mm (5.5") window
EFCT-9RF	Earth-Fault Current Sensor, 160 mm (6.3") window
EFCT-10RF	Earth-Fault Current Sensor, 200 mm (7.9") window

For additional information and to order EFCT-XRF sensors, contact sales@startco.com.au.

NOTES:

- ⁽¹⁾ Tamper-resistant screws must be used for AS/NZS 2081:2011 compliance.

6. WARRANTY

The SE-703 Earth-Leakage Monitor is warranted to be free from defects in material and workmanship for a period of five years from the date of purchase.

Littelfuse Startco will (at Littelfuse Startco's option) repair, replace, or refund the original purchase price of an SE-703 that is determined by Littelfuse Startco to be defective if it is returned to the factory, freight prepaid, within the warranty period. This warranty does not apply to repairs required as a result of misuse, negligence, an accident, improper installation, tampering, or insufficient care. Littelfuse Startco does not warrant products repaired or modified by non-Littelfuse Startco personnel.

7. EARTH-FAULT PERFORMANCE TEST

Some jurisdictions require periodic earth-fault performance tests. A test-record form is provided for recording the date and the results of the performance tests. The following earth-fault system tests are to be conducted by qualified personnel:

- a) Evaluate the interconnected system in accordance with the overall equipment manufacturer's detailed instructions.
- b) Verify proper location of the earth-fault current sensor. Ensure the cables pass through the earth-fault-current-sensor window. This check can be done visually with knowledge of the circuit. The connection of the current-sensor secondary to the SE-703 is not polarity sensitive.
- c) Verify that the system is correctly earthed and that alternate earth paths do not exist that bypass the current sensor. High-voltage testers and resistance bridges can be used to determine the existence of alternate earth paths.
- d) Verify proper reaction of the circuit-interrupting device in response to a simulated or controlled earth-fault current. To simulate earth-fault current, use CT-primary current injection. Fig. 11 shows a test circuit using an SE-400 Ground-Fault-Relay Test Unit. The SE-400 has a programmable output of 0.5 to 9.9 A for a duration of 0.1 to 9.9 seconds.

Fig. 11 shows the use of resistors that reduce the injected current to 10% of the SE-400 setting. Set the test current to 120% of the SE-703 setting. Inject the test current through the current-sensor window for at least 2.5 seconds. Verify that the circuit under test has reacted properly. Correct any problems and re-test until the proper reaction is verified.

- e) Record the date and the results of the test on the attached test-record form.

NOTE: Do not inject test current directly into CT-input terminals 4 and 5.

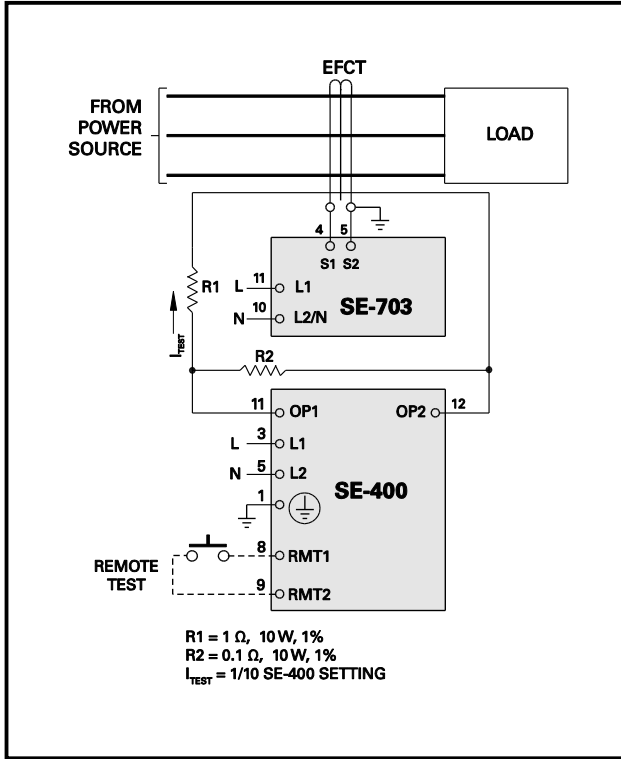

FIGURE 11. Earth-Fault-Test Circuit.

TABLE 1. EARTH-FAULT-TEST RECORD

DATE	TEST RESULTS

Retain this record for the authority having jurisdiction.

APPENDIX A SE-703 REVISION HISTORY

MANUAL RELEASE DATE	MANUAL REVISION	PRODUCT REVISION (REVISION NUMBER ON PRODUCT LABEL)
September 21, 2017	12-B-092117	08
March 10, 2017	12-A-031017	
March 10, 2016	11-C-031016	07
August 28, 2014	11-B-082814	
April 21, 2014	11-A-042114	
April 23, 2013	10-A-042313	06

MANUAL REVISION HISTORY

REVISION 12-B-092117

SECTION 4

SECTION 5

Updated certification information.

REVISION 12-A-031017

SECTION 2

Added Figs. 1A, 1B and 1C.

SECTION 3

Updated Figs. 2 and 3.

Added Fig. 10.

SECTION 4

Added ordering option details.

SECTION 5

Added ordering options.

SECTION 7

Added Fig. 11.

REVISION 11-C-031016

SECTION 5

Terminal torque specification added.

RCM certification added.

REVISION 11-B-082814

SECTION 3

EFCT-x figures updated.

SECTION 4

EMC Test specifications updated.

REVISION 11-A-042114

AS/NZS 2081:2011 compliance added.

Section 4 removed.

SECTION 3

Figs. 2, 3, 4, 5, 6, and 9 updated.

SECTION 4

Update to include altitude and vibration specifications.

FCC certification added.

SECTION 5

Ordering information updated.

SECTION 7

Fig. 10 updated.

REVISION 10-A-042313

SECTION 3

Figs. 2 and 3 updated to include PGA-05CV.

SECTION 5

Environment section updated to include Fahrenheit temperature range.

APPENDIX A

Revision history added.

PRODUCT REVISION HISTORY**REVISION 08**

Firmware: Trip levels updated for compliance with AS/NZS 2081:2011 (ordering option SE-703-0x-00) and AS/NZS 2081:2002 (ordering option SE-703-0x-02).

Hardware: Added two Form-C relays. RoHS2 compliance.

REVISION 07

Firmware: Trip levels updated for compliance with AS/NZS 2081:2011.

Hardware: Full conformal coating on all PCB's.

REVISION 06

Firmware: Improved operation of front-panel test button.