

# 2.5V CMOS Low Jitter XO

**FD**



5.0 x 3.2mm Ceramic SMD

### Product Features

- 1 to 133 MHz Frequency Range
- <1 ps RMS jitter with fundamental or overtone design
- Low power standby mode
- Pb-free and RoHS/Green compliant

### Product Description

The FD Series 2.5V crystal clock oscillator achieves superb jitter and stability over a broad range of operating conditions and frequencies. The output clock signal, generated internally with a non-PLL oscillator design, is compatible with LVCMOS/LVTTL logic levels. The device, available on tape and reel, is contained in a 5.0 x 3.2mm surface-mount ceramic package.

### Applications

The FD Series is ideal for compact, high-density applications requiring low jitter or tight stability, including:

- Ethernet
- EPON
- Fibre Channel
- Serial Attached SCSI (SAS)
- Server & Storage platforms
- SONET/SDH linecards
- T1/E1, T3/E3 linecards
- DSLAM
- 802.11a/b/g WiFi

### Package:

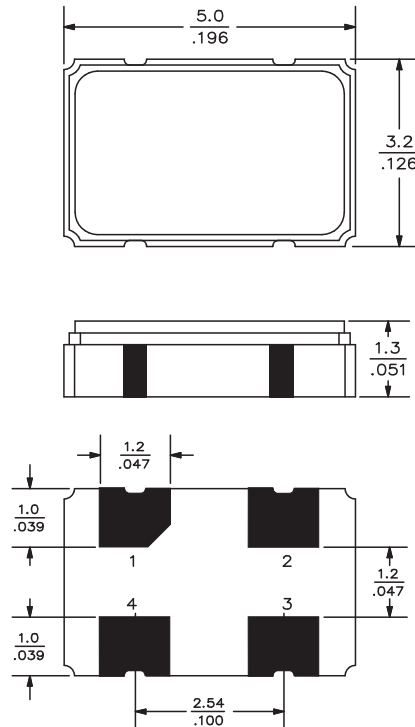

### Recommended Land Pattern:

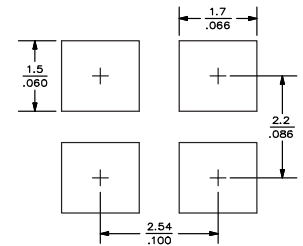

### Pin Functions:

| Pin | Function        |
|-----|-----------------|
| 1   | OE Function     |
| 2   | Ground          |
| 3   | Clock Output    |
| 4   | V <sub>DD</sub> |

### Part Ordering Information:

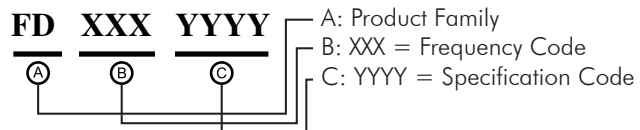

Following the above format, Saronix-eCera part numbers will be assigned upon confirmation of exact customer requirements.

### Legacy Ordering Information - For Reference Only:

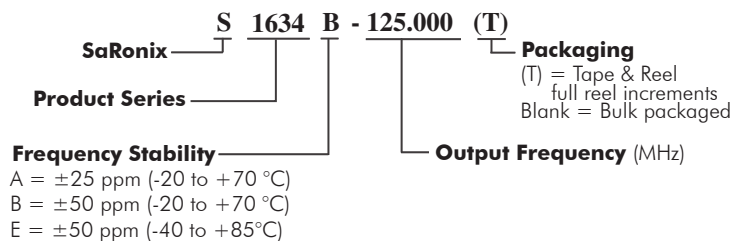

### Electrical Performance

| Parameter                       | Min.                | Typ. | Max.                | Units        | Notes                          |
|---------------------------------|---------------------|------|---------------------|--------------|--------------------------------|
| Output Frequency                | 1                   |      | 133                 | MHz          | As specified                   |
| Supply Voltage                  | 2.25                | 2.50 | 2.75                | V            |                                |
| Supply Current, Output Enabled  |                     |      | 15                  | mA           | 1 to 32 MHz                    |
|                                 |                     |      | 25                  |              | 32 to 50 MHz                   |
|                                 |                     |      | 35                  |              | 50 to 133 MHz                  |
| Supply Current, Standby Mode    |                     |      | 10                  | μA           | Output Hi-Z                    |
| Frequency Stability             |                     |      | ±20 to ±50          | ppm          | See Note 1 below               |
| Operating Temperature Range     | -20                 |      | +70                 | °C           | Commercial (standard)          |
|                                 | -40                 |      | +85                 |              | Industrial (standard)          |
| Output Logic 0, V <sub>OL</sub> |                     |      | 10% V <sub>DD</sub> | V            |                                |
| Output Logic 1, V <sub>OH</sub> | 90% V <sub>DD</sub> |      |                     | V            |                                |
| Output Load                     |                     |      | 15                  | pF           | See Note 2 below               |
| Duty Cycle                      | 45                  |      | 55                  | %            | Measured 50% V <sub>DD</sub>   |
| Rise and Fall Time              | up to 32 MHz        |      | 7                   | ns           | Measured 20/80% of waveform    |
|                                 | 32 to 70 MHz        |      | 5                   |              |                                |
|                                 | 70 to 133 MHz       |      | 2.5                 |              |                                |
| Jitter, Phase                   | 1 to 133 MHz        |      | 1                   | ps RMS (1-σ) | 10kHz to 20 MHz frequency band |
| Jitter, Accumulated             | up to 70 MHz        |      | 5                   | ps RMS (1-σ) | 20.000 adjacent periods        |
|                                 | 70 to 133 MHz       |      | 3                   |              |                                |
| Jitter, Total                   | up to 70 MHz        |      | 50                  | ps pk-pk     | 100.000 random periods         |
|                                 | 70 to 133 MHz       |      | 30                  |              |                                |

#### Notes:

- Stability includes all combinations of operating temperature, load changes, rated input (supply) voltage changes, initial calibration tolerance (25°C), aging (1 year at 25°C average effective ambient temperature), shock and vibration.
- For specifications other than those listed, please contact sales.

### Output Enable / Disable Function

| Parameter   | Min. | Typ. | Max. | Units | Notes          |
|---|------|------|------|-------|----------------|
| Input Voltage (pin 1), Output Enable                      | 0.7  |      |      | V     | or open        |
| Input Voltage (pin 1), Output Disable (low power standby) |      |      | 0.3  | V     | Output is Hi-Z |
| Internal Pullup Resistance                                | 50   |      |      | kΩ    |                |
| Output Disable Delay                                      |      |      | 100  | ns    |                |
| Output Enable Delay                                       |      |      | 10   | ms    |                |

### Absolute Maximum Ratings

| Parameter           | Min. | Typ. | Max. | Units | Notes |
|---------------------|------|------|------|-------|-------|
| Storage Temperature | -55  |      | +125 | °C    |       |

### Test Circuit

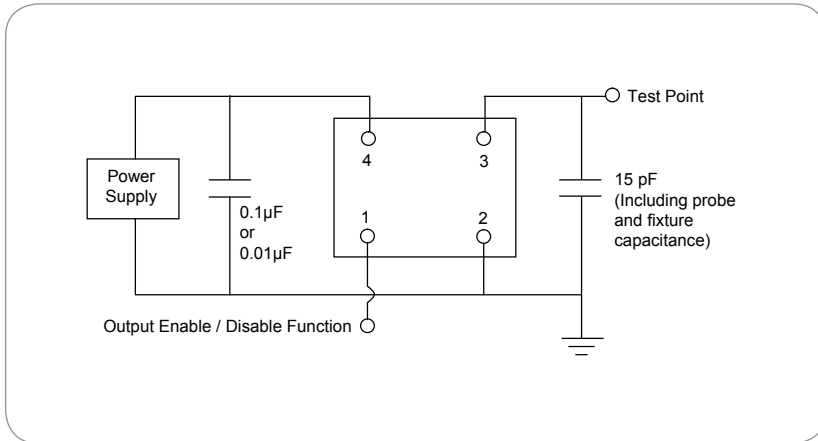

### Reflow Soldering Profile

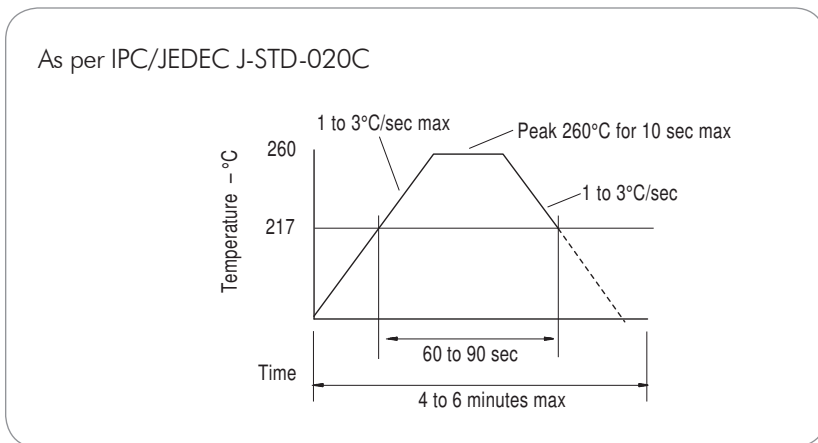

### Reliability Test Ratings

This product is rated to meet the following test conditions:

| Type          | Parameter                    | Test Condition  |
|---------------|------------------------------|---|
| Mechanical    | Shock                        | MIL-STD-883, Method 2002, Condition B                                       |
| Mechanical    | Solderability                | JESD22-B102-D Method 2 (Preconditioning E)                                  |
| Mechanical    | Terminal strength            | MIL-STD-883, Method 2004, Condition D                                       |
| Mechanical    | Gross leak                   | MIL-STD-883, Method 1014, Condition C                                       |
| Mechanical    | Fine leak                    | MIL-STD-883, Method 1014, Condition A2 ( $R_1 = 2 \times 10^{-8}$ atm cc/s) |
| Mechanical    | Solvent resistance           | MIL-STD-202, Method 215   |
| Environmental | Thermal shock                | MIL-STD-883, Method 1011, Condition A                                       |
| Environmental | Moisture resistance          | MIL-STD-883, Method 1004  |
| Environmental | Vibration                    | MIL-STD-883, Method 2007, Condition A                                       |
| Environmental | Resistance to soldering heat | J-STD-020C Table 5-2 Pb-free devices (2 cycles max)                         |