

Silicon N-P-N and P-N-P Epitaxial-Base Complementary-Symmetry Transistors

General-Purpose Types for Switching and Linear-Amplifier Applications

Features:

- Low saturation voltages
- Maximum safe-area-of-operation curves
- High gain at high current
- High breakdown voltages

The 2N5781, 2N5782, and 2N5783 are epitaxial-base silicon p-n-p transistors — complements of the silicon n-p-n types 2N5784, 2N5785, and 2N5786*, respectively.

The three types in each family differ primarily in voltage ratings and saturation characteristics.

These transistors are intended for medium-power switching and complementary-symmetry audio amplifier applications.

All types are supplied in the JEDEC TO-205AD package.

- Formerly RCA Dev. Types TA7270, TA7271, TA7272, TA7289, TA7290, and TA7291 respectively.

TERMINAL DESIGNATIONS

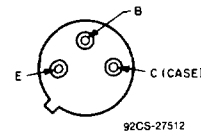

JEDEC TO-205AD

MAXIMUM RATINGS, Absolute-Maximum Values:

	P-N-P	2N5781 [♦]	2N5782 [♦]	2N5783 [♦]	
	N-P-N	2N5784	2N5785	2N5786	
*COLLECTOR-TO-BASE VOLTAGE	V_{CBO}	80	65	45	V
COLLECTOR-TO-EMITTER SUSTAINING VOLTAGE:					
* With external base-to-emitter resistance (R_{BE}) = 100 Ω	$V_{CER(sus)}$	80	65	45	V
With base open	$V_{CEO(sus)}$	65	50	40	V
*EMITTER-TO-BASE VOLTAGE	V_{EBO}	5	5	3.5	V
*CONTINUOUS COLLECTOR CURRENT	I_C	3.5	3.5	3.5	A
*CONTINUOUS BASE CURRENT	I_B	1	1	1	A
*TRANSISTOR DISSIPATION:	P_T				
At case temperatures up to 25°C		10	10	10	W
At ambient temperatures up to 25°C		1	1	1	W
At case temperatures above 25°C	Derate linearly	0.057 W/°C, or see Fig. 7.			
At ambient temperatures above 25°C	Derate linearly	0.0057			W/°C
*TEMPERATURE RANGE:		-65 to +200			°C
Storage and operating (Junction)					
*LEAD TEMPERATURE (During soldering):		230			°C
At distance \geq 1/32 in. (0.8 mm) from seating plane for 10 s max.					

*In accordance with JEDEC registration data format JS-6 RDF-2.

♦For p-n-p devices, voltage and current values are negative.

2N5781, 2N5782, 2N5783, 2N5784, 2N5785, 2N5786

ELECTRICAL CHARACTERISTICS, At Case Temperature (T_C) = 25°C unless otherwise specified

CHARACTERISTIC	SYMBOL	TEST CONDITIONS*				LIMITS				UNITS
		VOLTAGE V dc		CURRENT A dc		2N5781 p-n-p		2N5784 n-p-n		
		V_{CE}	V_{BE}	I_C	I_B	Min.	Max.	Min.	Max.	
Collector Cutoff Current: With external base-to-emitter resistance (R_{BE}) = 100 Ω	I_{CER}	65				–	–10	–	10	μA
At $T_C = 150^\circ C$		65				–	–1	–	1	mA
* With base-emitter junction reverse- biased and external base-to-emitter resistance (R_{BE}) = 100 Ω	I_{CEX}	–75	1.5			–	–10	–	–	μA
At $T_C = 150^\circ C$		75	–1.5			–	–	–	10	mA
* With base open	I_{CEO}	50			0	–	–100	–	100	μA
* Emitter Cutoff Current	I_{EBO}		–5	0		–	–10	–	10	μA
* DC Forward-Current Transfer Ratio	h_{FE}	2		1 ^a		20	100	20	100	
		2		3.2 ^a		4	–	4	–	
* Collector-to-Emitter Sustaining Voltage (see Figs. 2 and 3): With base open	$V_{CEO(sus)}$			0.1 ^a	0	–65 ^b	–	65 ^b	–	V
With external base-to-emitter resistance (R_{BE}) = 100 Ω	$V_{CER(sus)}$			0.1 ^a		–80 ^b	–	80 ^b	–	V
* Base-to-Emitter Voltage	V_{BE}	2		1 ^a		–	–1.5	–	1.5	V
* Collector-to-Emitter Saturation Voltage (measured 0.25 in (6.35 mm) from case) ^c	$V_{CE(sat)}$			1 ^a	0.1	–	–0.5	–	0.5	V
* Magnitude of Common-Emitter, Small-Signal, Short-Circuit, Forward-Current Transfer Ratio ^d $f = 4$ MHz	$ h_{fe} $	–2		–0.1		2	15	–	–	
$f = 200$ kHz		2		0.1				5	20	
* Common-Emitter, Small-Signal, Short-Circuit, Forward-Current Transfer Ratio ($f = 1$ kHz)	h_{fe}	2		0.1		25	–	25	–	
Saturated Switching Time ($V_{CC} =$ 30 V, $I_{B1} = I_{B2}$): Turn-on ($t_d + t_r$)	t_{ON}			–1	–0.1	–	0.5	–	–	μs
Turn-off ($t_s + t_f$)	t_{OFF}			1	0.1	–	–	–	5	
Thermal Resistance: Junction-to-case	$R_{\theta JC}$					–	17.5	–	17.5	$^\circ C/W$
Junction-to-ambient	$R_{\theta JA}$					–	175	–	175	

* In accordance with JEDEC registration data format JS-6 RDF-2. ♦ For p-n-p devices, voltage and current values are negative.

^a Pulsed, pulse duration = 300 μs , duty factor = 1.8%

^c Lead resistance is critical in this test.

^b CAUTION: Sustaining voltages $V_{CEO(sus)}$, and $V_{CER(sus)}$ MUST NOT be measured on a curve tracer.

^d Measured at a frequency where $|h_{fe}|$ is decreasing at approximately 6 dB per octave.

2
POWER
TRANSISTORS

2N5781, 2N5782, 2N5783, 2N5784, 2N5785, 2N5786

ELECTRICAL CHARACTERISTICS, At Case Temperature (T_C) = 25°C unless otherwise specified

CHARACTERISTIC	SYMBOL	TEST CONDITIONS [♦]				LIMITS				UNITS
		VOLTAGE V dc		CURRENT A dc		2N5782 p-n-p		2N5785 n-p-n		
		V _{CE}	V _{BE}	I _C	I _B	Min.	Max.	Min.	Max.	
Collector Cutoff Current: With external base-to-emitter resistance (R _{BE}) = 100 Ω	I _{CER}	50				–	–10	–	10	μA
At T _C = 150°C		50				–	–1	–	1	mA
* With base-emitter junction reverse- biased and external base-to-emitter resistance (R _{BE}) = 100 Ω	I _{CEx}	–60	1.5			–	–10	–	–	μA
		60	–1.5			–	–	–	10	
* At T _C = 150°C		–60	1.5			–	–1	–	–	mA
	60	–1.5				–	–	–	1	
* With base open	I _{CEO}	35			0	–	–100	–	100	μA
* Emitter Cutoff Current	I _{EBO}		–5	0		–	–10	–	10	μA
* DC Forward-Current Transfer Ratio	h _{FE}	2		1.2 ^a		20	100	20	100	
		2		3.2 ^a		4	–	4	–	
* Collector-to-Emitter Sustaining Voltage (see Figs. 2 and 3): With base open	V _{CEO(sus)}			0.1 ^a	0	–50 ^b	–	50 ^b	–	V
With external base-to-emitter resistance (R _{BE}) = 100 Ω	V _{CER(sus)}			0.1 ^a		–65 ^b	–	65 ^b	–	
* Base-to-Emitter Voltage	V _{BE}	2		1.2 ^a		–	–1.5	–	1.5	V
* Collector-to-Emitter Saturation Voltage (measured 0.25 in (6.35 mm) from case) ^c	V _{CE(sat)}			1.2 ^a	0.12	–	–0.75	–	0.75	V
				3.2 ^a	0.8	–	–2	–	2	
* Magnitude of Common-Emitter, Small-Signal, Short-Circuit, Forward-Current Transfer Ratio ^d	h _{fe}									
f = 4 MHz		–2		–0.1		2	15	–	–	
f = 200 kHz	2		0.1		–	–	5	20		
* Common-Emitter, Small-Signal, Short-Circuit, Forward-Current Transfer Ratio (f = 1 kHz)	h _{fe}	2		0.1		25	–	25	–	
Saturated Switching Time (V _{CC} = 30 V, I _{B1} = I _{B2}):										
Turn-on (t _d + t _r)	t _{ON}			–1	–0.1	–	0.5	–	–	μs
				1	0.1	–	–	–	5	
Turn-off (t _s + t _f)	t _{OFF}			–1	–0.1	–	2.5	–	–	
				1	0.1	–	–	–	15	
Thermal Resistance: Junction-to-case	R _{θJC}						17.5	–	17.5	°C/W
Junction-to-ambient	R _{θJA}					–	175	–	175	

* In accordance with JEDEC registration data format JS-6 RDF-2.

^a Pulsed, pulse duration = 300 μs, duty factor = 1.8%.

^b CAUTION: Sustaining voltages V_{CEO(sus)}, and V_{CER(sus)} MUST NOT be measured on a curve tracer.

[♦] For p-n-p devices, voltage and current values are negative.

^c Lead resistance is critical in this test.

^d Measured at a frequency where |h_{fe}| is decreasing at approximately 6 dB per octave.

2N5781, 2N5782, 2N5783, 2N5784, 2N5785, 2N5786

ELECTRICAL CHARACTERISTICS. At Case Temperature (T_C) = 25°C unless otherwise specified

CHARACTERISTIC	SYMBOL	TEST CONDITIONS [♦]				LIMITS				UNITS
		VOLTAGE V dc		CURRENT A dc		2N5783 p-n-p		2N5786 n-p-n		
		V _{CE}	V _{BE}	I _C	I _B	Min.	Max.	Min.	Max.	
Collector Cutoff Current: With external base-to-emitter resistance (R _{BE}) = 100 Ω	I _{CER}	40				-	-10	-	10	μA
At T _C = 150°C		40				-	-1	-	1	mA
* With base-emitter junction reverse- biased and external base-to-emitter resistance (R _{BE}) = 100 Ω	I _{CEX}	-45	1.5			-	-10	-	-	μA
		45	-1.5			-	-	-	10	
* At T _C = 150°C	I _{CEX}	-45	1.5			-	-1	-	-	mA
		45	-1.5			-	-	-	1	
* With base open	I _{CEO}	25			0	-	-100	-	100	μA
* Emitter Cutoff Current	I _{EBO}		-3.5	0		-	-10	-	10	μA
* DC Forward-Current Transfer Ratio	h _{FE}	2		1.6 ^a		20	100	20	100	
		2		3.2 ^a		4	-	4	-	
* Collector-to-Emitter Sustaining Voltage (see Figs. 2 and 3): With base open	V _{CEO(sus)}			0.1 ^a	0	-40 ^b	-	40 ^b	-	V
With external base-to-emitter resistance (R _{BE}) = 100 Ω	V _{CER(sus)}			0.1 ^a		-45 ^b	-	45 ^b	-	V
* Base-to-Emitter Voltage	V _{BE}	2		1.6 ^a		-	-1.5	-	1.5	V
* Collector-to-Emitter Saturation Voltage (measured 0.25 in (6.35 mm) from case) ^c	V _{CE(sat)}			1.6 ^a	0.16	-	-1	-	1	V
				3.2 ^a	0.8	-	-2	-	2	
* Magnitude of Common-Emitter, Small-Signal, Short-Circuit, Forward-Current Transfer Ratio ^d	h _{fe}									
f = 4 MHz		-2		-0.1		2	15	-	-	
f = 200 kHz	2		0.1		-	-	5	20		
* Common-Emitter, Small-Signal, Short-Circuit, Forward-Current Transfer Ratio (f = 1 kHz)	h _{fe}	2		0.1		25	-	25	-	
Saturated Switching Time (V _{CC} = 30 V, I _{B1} = I _{B2}):	t _{ON}									
Turn-on (t _d + t _r)										
Turn-off (t _s + t _f)	t _{OFF}			-1	-0.1	-	2.5	-	-	15
				1	0.1	-	-	-	15	
Thermal Resistance:	R _θ									
Junction-to-case		JC						17.5	-	17.5
Junction-to-ambient	JA						-	175	-	175

* In accordance with JEDEC registration data format JS-6 RDF-2.

^a Pulsed, pulse duration = 300 μs, duty factor = 1.8%.

^b CAUTION: Sustaining voltages V_{CEO(sus)}, and V_{CER(sus)} MUST NOT be measured on a curve tracer.

[♦] For p-n-p devices, voltage and current values are negative.

^c Lead resistance is critical in this test.

^d Measured at a frequency where |h_{fe}| is decreasing at approximately 6 dB per octave.

2
POWER TRANSISTORS

2N5781, 2N5782, 2N5783, 2N5784, 2N5785, 2N5786

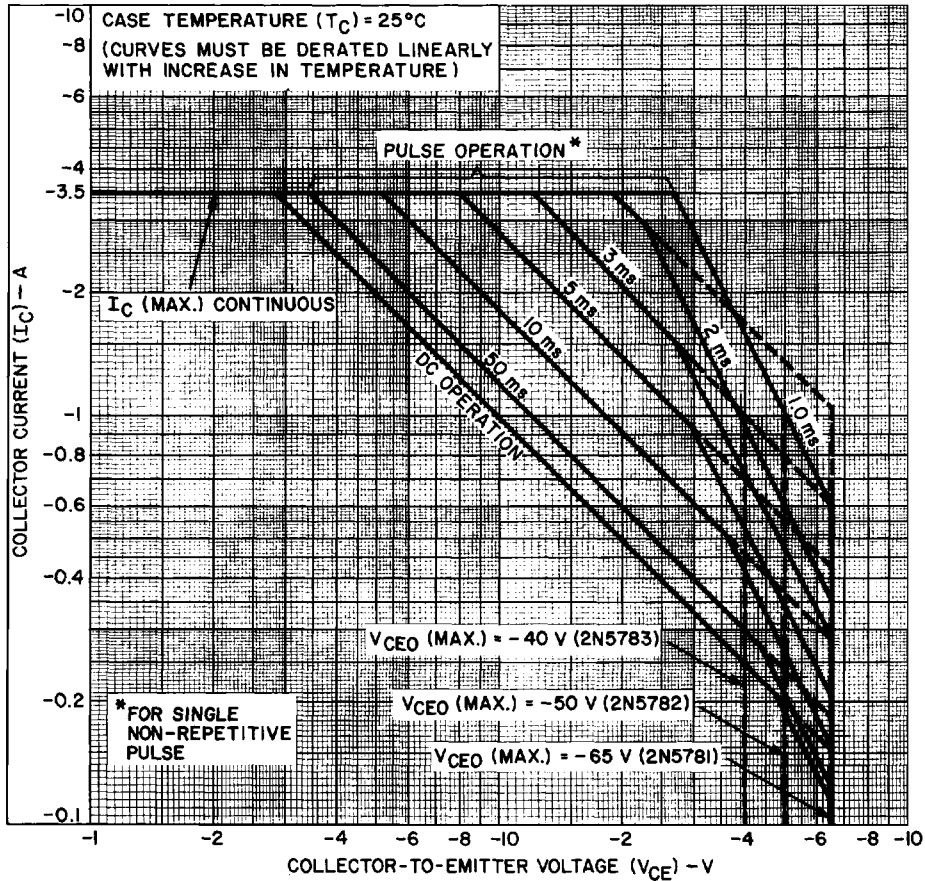
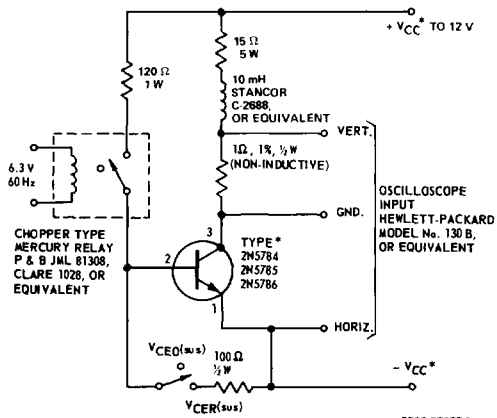

Fig. 1 - Maximum operating areas for types 2N5781, 2N5782, and 2N5783.

92CS-23943



* FOR P-N-P TYPES 2N5781, 2N5782, & 2N5783, REVERSE POLARITY OF V_{CC} .

Fig. 2 - Circuit used to measure sustaining voltages $V_{CE0(sus)}$ and $V_{CER(sus)}$.

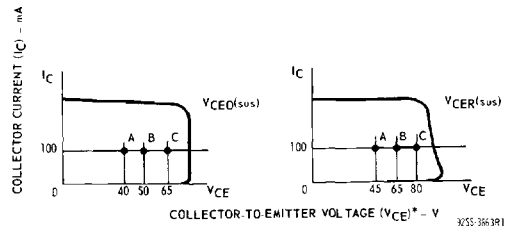

* FOR TYPES 2N5781, 2N5782, AND 2N5783, THE VALUES FOR I_C AND V_{CE} ARE NEGATIVE.

The sustaining voltages $V_{CE0(sus)}$ and $V_{CER(sus)}$ are acceptable when the trace fails to the right and above point "A" (2N5783 & 2N5786), "B" (2N5782 & 2N5785), or "C" (2N5781 & 2N5784).

Fig. 3 - Oscilloscope display for measurement of sustaining voltages. (Test circuit shown in Fig. 2).

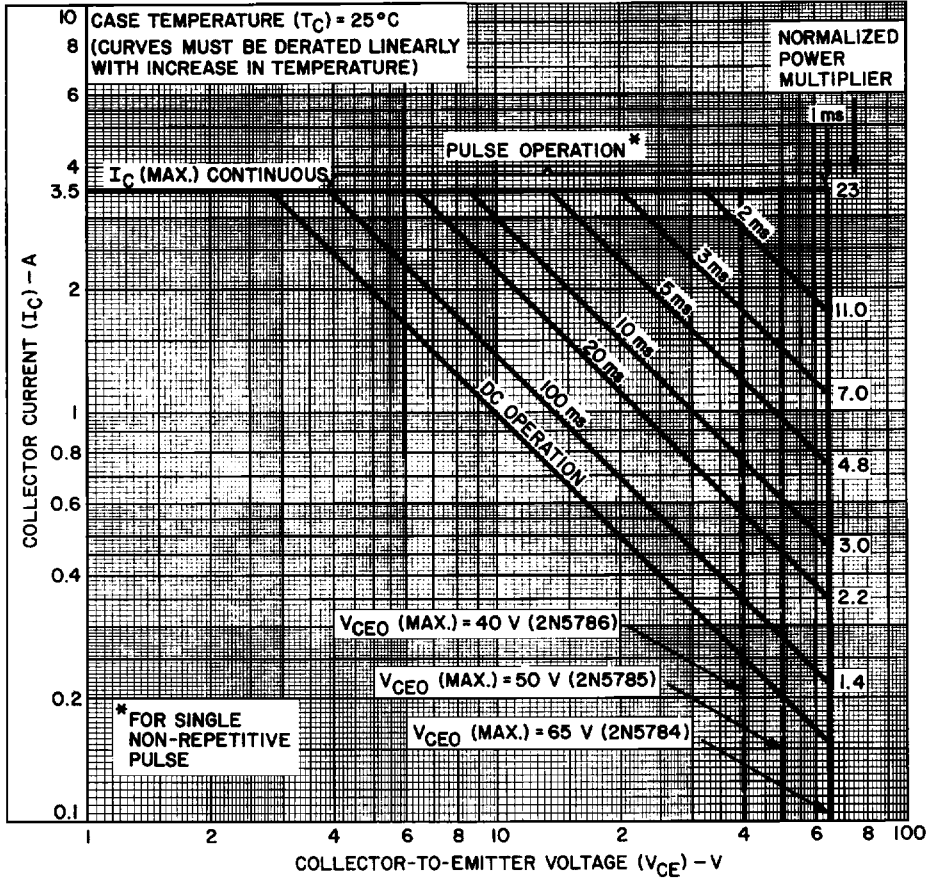

92CS-23944

Fig. 4 - Maximum operating areas for types 2N5784, 2N5785, and 2N5786.

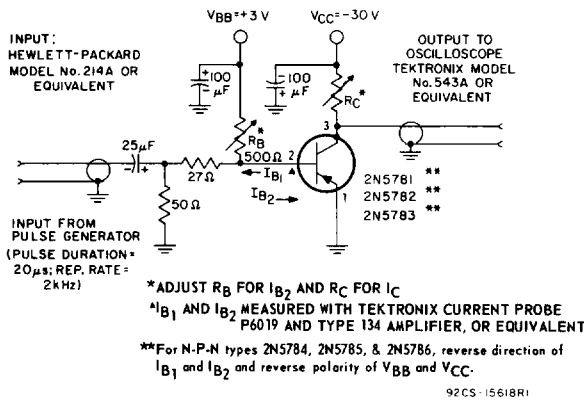

Fig. 5 - Circuit used to measure saturated switching times.

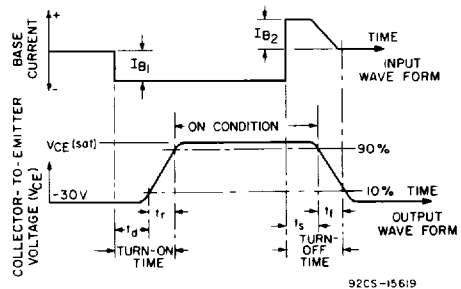

Fig. 6 - Oscilloscope display for measurement of switching times. (Test circuit shown in Fig. 5).

2N5781, 2N5782, 2N5783, 2N5784, 2N5785, 2N5786

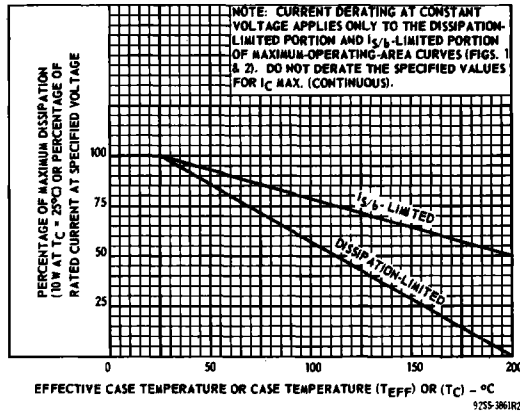

Fig. 7 - Dissipation derating curve for all types.

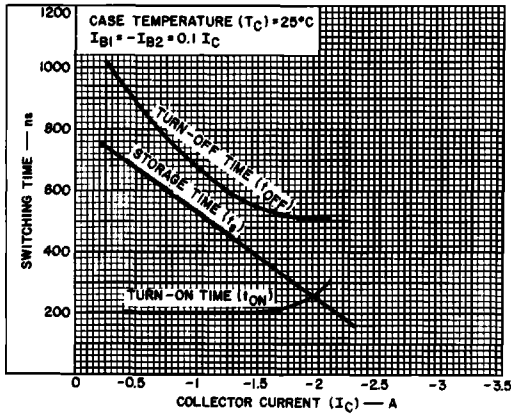

Fig. 8 - Typical saturated switching characteristics for types 2N5781, 2N5782, and 2N5783.

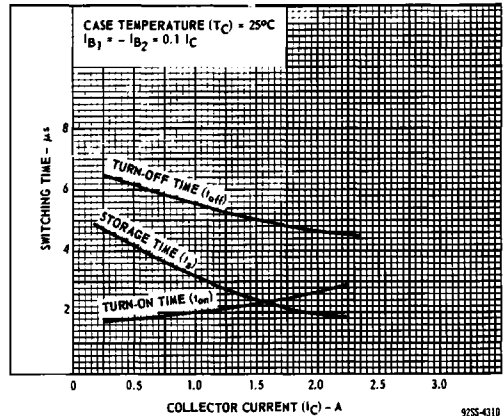

Fig. 9 - Typical saturated switching characteristics for types 2N5784, 2N5785, and 2N5786.

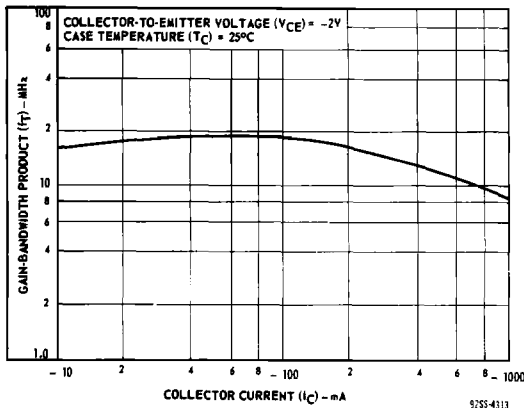

Fig. 10 - Typical gain-bandwidth product for types 2N5781, 2N5782, and 2N5783.

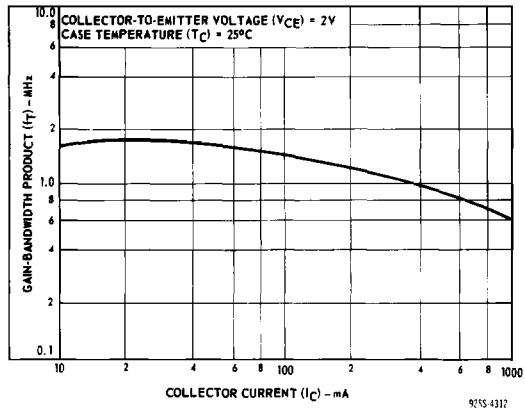

Fig. 11 - Typical gain-bandwidth product for types 2N5784, 2N5785, and 2N5786.

2N5781, 2N5782, 2N5783, 2N5784, 2N5785, 2N5786

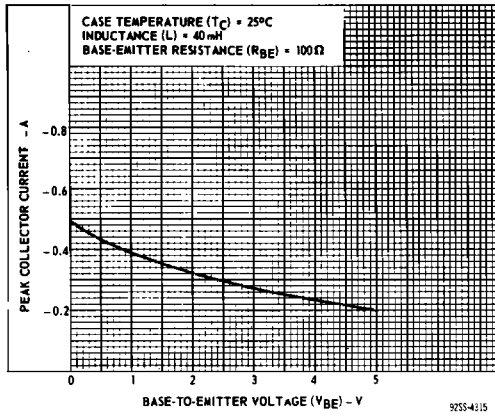

Fig. 12 – Reverse-bias second-breakdown characteristics for types 2N5781, 2N5782, and 2N5783.

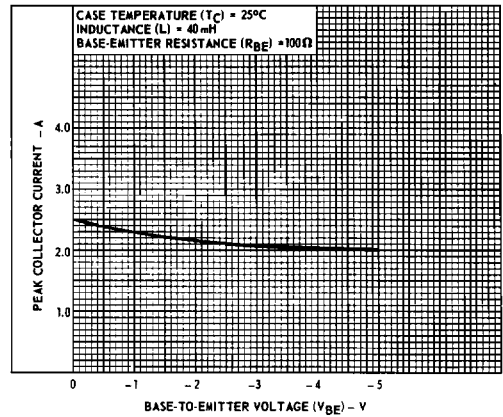

Fig. 13 – Reverse-bias second-breakdown characteristics for types 2N5784, 2N5785, and 2N5786.

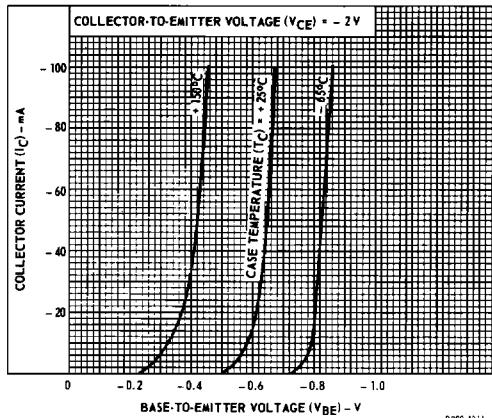

Fig. 14 – Typical transfer characteristics for types 2N5781, 2N5782, and 2N5783.

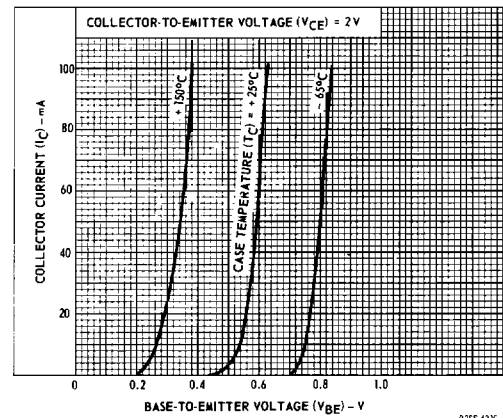

Fig. 15 – Typical transfer characteristics for types 2N5784, 2N5785, and 2N5786.

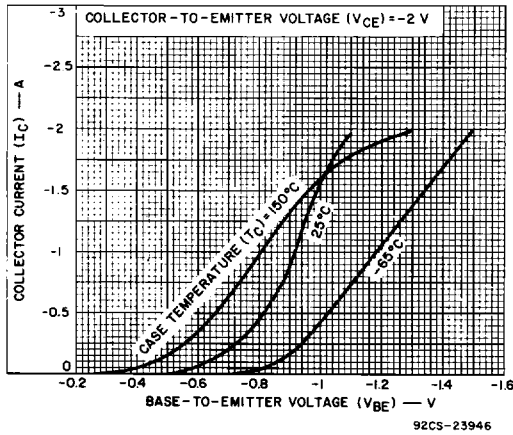

Fig. 16 – Typical transfer characteristics for types 2N5781, 2N5782, and 2N5783.

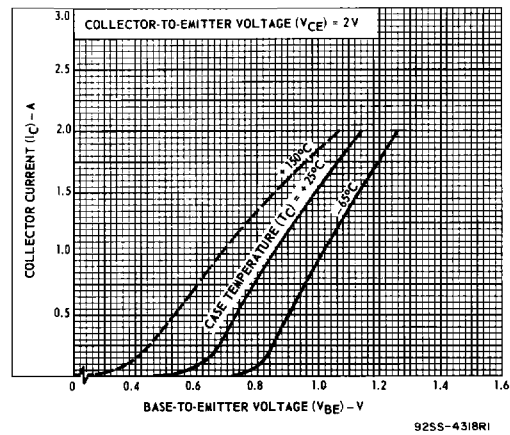

Fig. 17 – Typical transfer characteristics for types 2N5784, 2N5785, and 2N5786.

2N5781, 2N5782, 2N5783, 2N5784, 2N5785, 2N5786

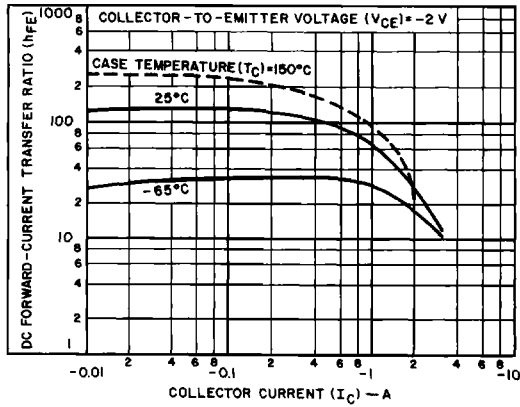

Fig. 18 - Typical dc beta characteristics for type 2N5781.

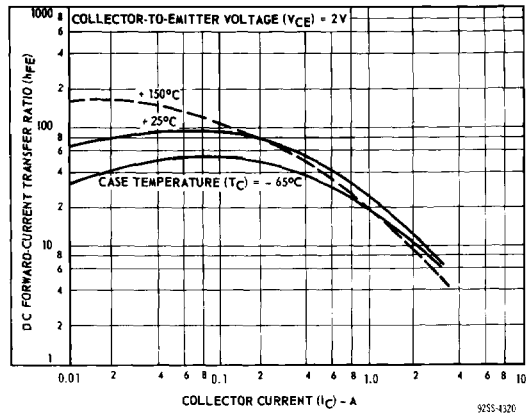

Fig. 19 - Typical dc beta characteristics for type 2N5784.

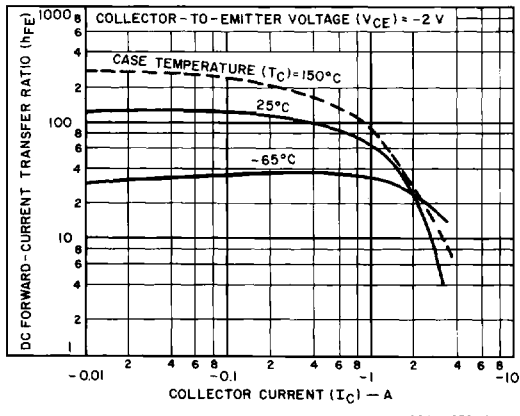

Fig. 20 - Typical dc beta characteristics for type 2N5782.

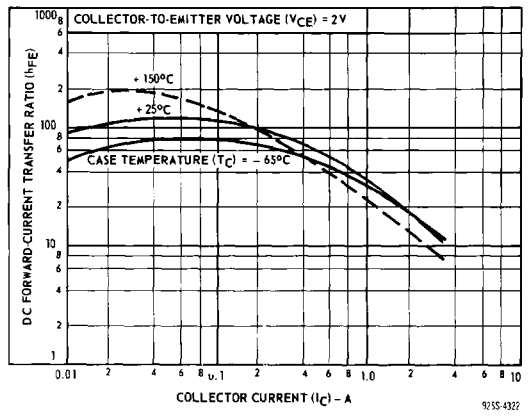

Fig. 21 - Typical dc beta characteristics for type 2N5785b.

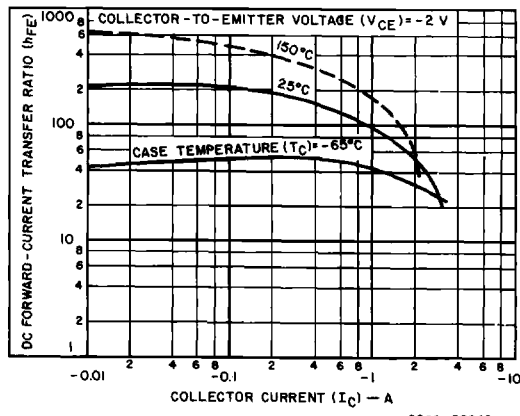

Fig. 22 - Typical dc beta characteristics for type 2N5783.

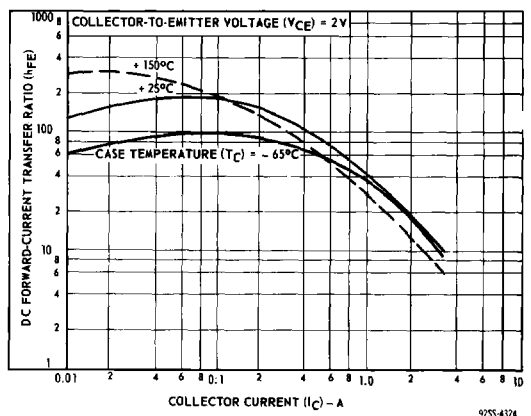

Fig. 23 - Typical dc beta characteristics for type 2N5786.

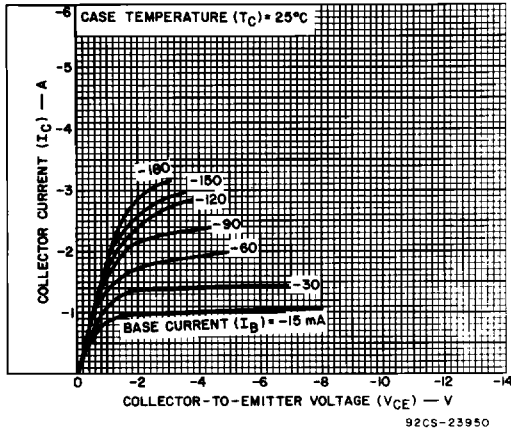

Fig. 24 – Typical output characteristics for type 2N5781.

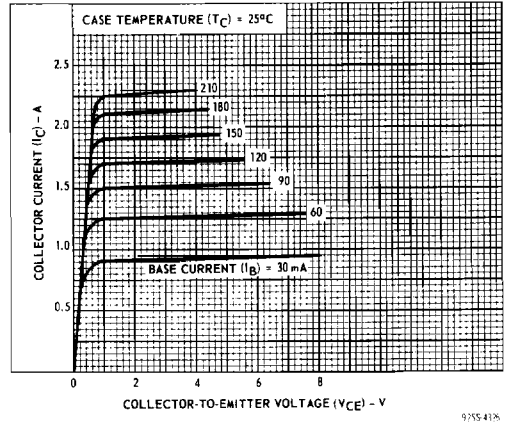

Fig. 25 – Typical output characteristics for type 2N5784.

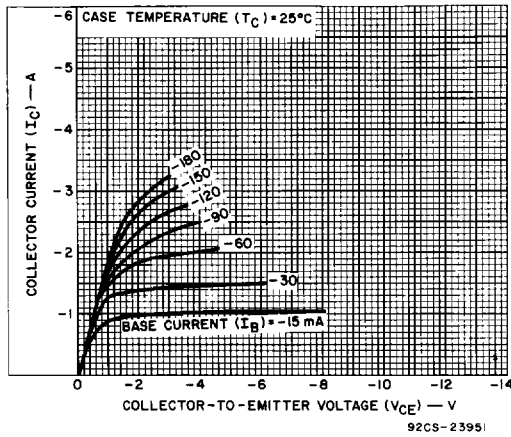

Fig. 26 – Typical output characteristics for type 2N5782.

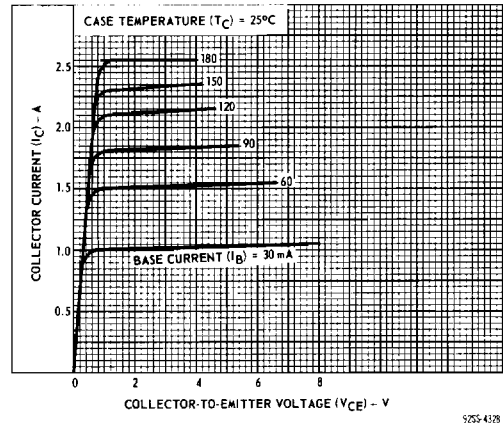

Fig. 27 – Typical output characteristics for type 2N5785.

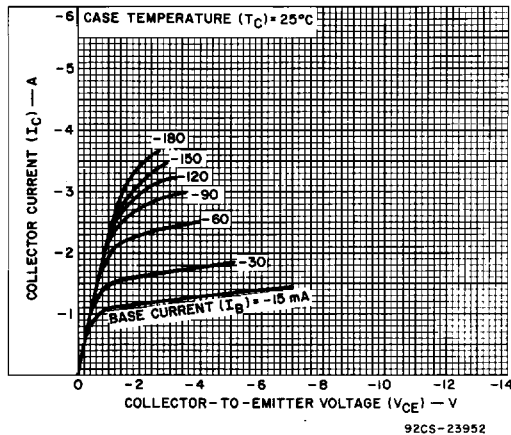

Fig. 28 – Typical output characteristics for type 2N5783.

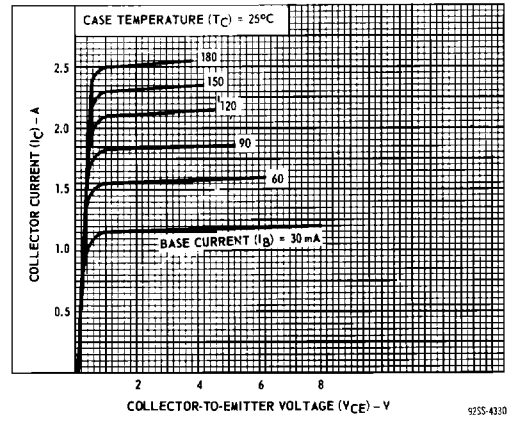

Fig. 29 – Typical output characteristics for type 2N5786.

2N5781, 2N5782, 2N5783, 2N5784, 2N5785, 2N5786

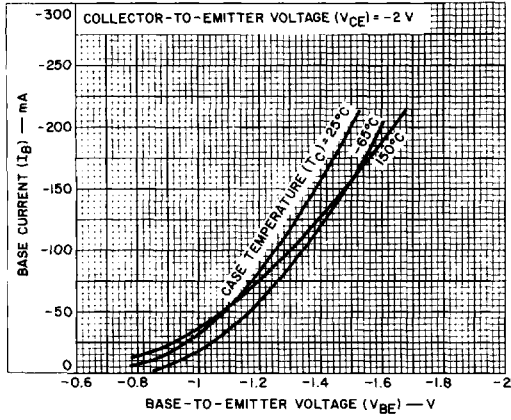

Fig. 30 — Typical input characteristics for type 2N5781.

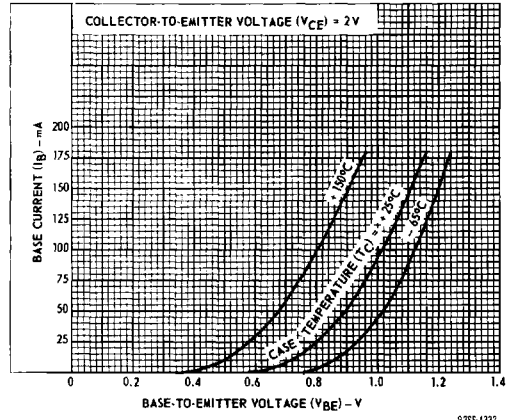

Fig. 31 — Typical input characteristics for type 2N5784.

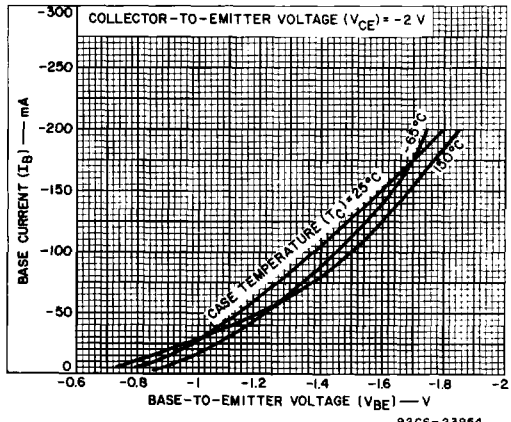

Fig. 32 — Typical input characteristics for type 2N5782.

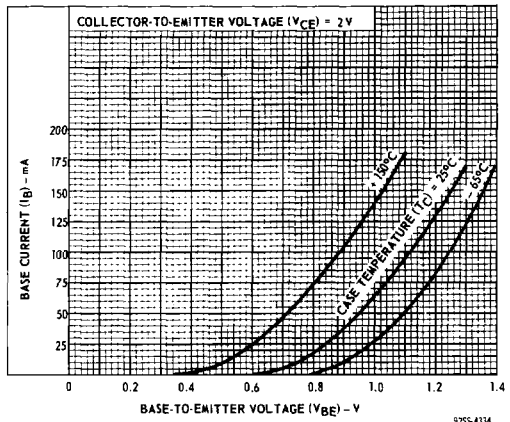

Fig. 33 — Typical input characteristics for type 2N5785.

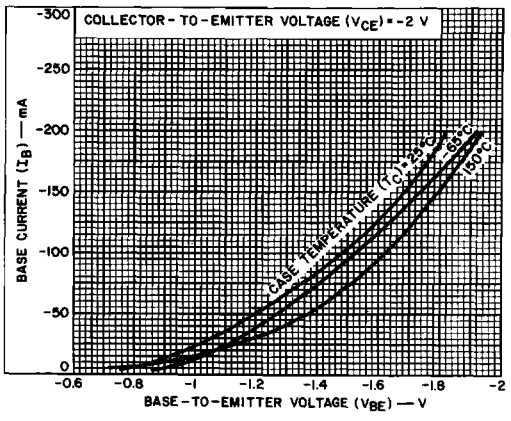

Fig. 34 — Typical input characteristics for type 2N5783.

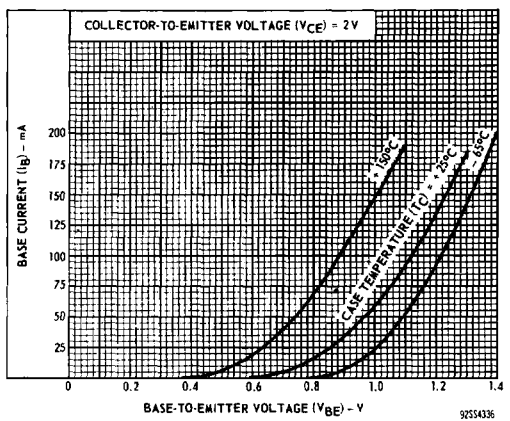

Fig. 35 — Typical input characteristics for type 2N5786.