

## Aluminum Electrolytic Capacitors Power Miniaturized General Purpose - Snap-In



Fig. 1

QUICK REFERENCE DATA	
DESCRIPTION	VALUE
Nominal case size (D x L in mm)	20 x 25 to 35 x 45
Rated capacitance range (E6 series), C <sub>R</sub>	820 μF to 47 000 μF
Tolerance on C <sub>R</sub>	± 20 %
Rated voltage range, U <sub>R</sub>	16 V to 100 V
Category temperature range	-40 °C to +105 °C
Endurance test at +105 °C	2000 h
Useful life at +105 °C	2000 h
Useful life at +85 °C	> 5000 h
Shelf life at 0 V, 105 °C	1000 h
Based on sectional specification	IEC 60384-4 / EN130300
Climatic category IEC 60068	40 / 105 / 56

### FEATURES

- Useful life: 2000 h at +105 °C, > 5000 h at +85 °C
- Voltage range from 16 V to 100 V
- Polarized aluminum electrolytic capacitors, non-solid electrolyte
- Pressure relief on the top of the aluminum case
- PET insulation sleeve
- Material categorization: for definitions of compliance please see [www.vishay.com/doc?99912](http://www.vishay.com/doc?99912)

**RoHS  
COMPLIANT**

### APPLICATIONS

- General purpose, industrial
- Standard and switched mode power supplies
- Audio systems
- DC/DC converters
- Telecom
- Smoothing and filtering

### MARKING

The capacitors are marked (where possible) with the following information:

- Rated capacitance (in μF)
- Tolerance on rated capacitance, code letter in accordance with IEC 60062 (± 20 %)
- Rated voltage (in V)
- Date code; abbreviation in 2 digits in accordance with IEC 60062
- Name of manufacturer
- Code for factory of origin (04)
- “-” sign to identify the negative terminal, visible from the top and side of the capacitor
- Relevant part of ordering code. Example MAL225638472E3, marking will show: 256 38472
- Climatic category in accordance with IEC 60068
- LL for Long Life

SELECTION CHART FOR C <sub>R</sub> , U <sub>R</sub> , AND RELEVANT NOMINAL CASE SIZES (∅ D x L in mm)							
C <sub>R</sub> (μF)	U <sub>R</sub> (V)						
	16	25	35	50	63	80	100
820	-	-	-	-	-	-	22 x 30
1200	-	-	-	-	22 x 25	-	25 x 30
1500	-	-	-	-	-	22 x 35	-
2200	-	-	-	22 x 25	22 x 30 25 x 25	25 x 30	25 x 40
2700	-	-	-	22 x 25	-	-	30 x 35
3300	-	-	22 x 25	22 x 30	25 x 35	35 x 25	30 x 40
3900	-	-	-	22 x 35	-	-	-
4700	-	-	22 x 25	25 x 30	25 x 40	35 x 30	35 x 40
5600	-	-	-	-	-	35 x 45	35 x 45
6800	-	-	25 x 30	25 x 40	35 x 30	35 x 40	-
8200	-	22 x 25	-	-	-	-	-
10 000	20 x 25	-	30 x 30	30 x 40	35 x 40	-	-
15 000	22 x 30	22 x 40	-	-	-	-	-
22 000	25 x 30	25 x 40	35 x 40	-	-	-	-
33 000	30 x 30	-	-	-	-	-	-
47 000	35 x 35	-	-	-	-	-	-

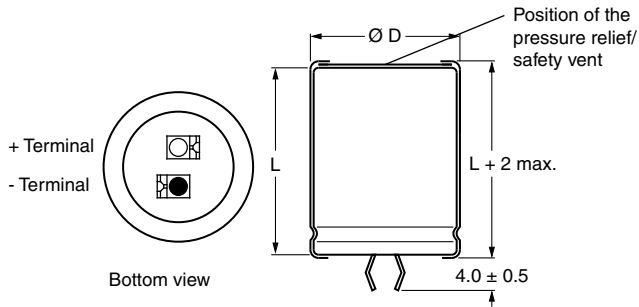
**DIMENSIONS in millimeters AND AVAILABLE FORMS**

The minus and/or plus terminal can be marked with an imprinted sign.

Fig. 2 - Two terminal snap-in

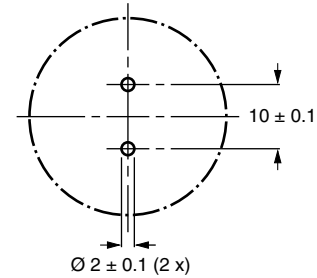

Fig. 3 - Mounting hole diagram

**Table 1**

<b>DIMENSIONS in millimeters, MASS AND PACKAGING QUANTITIES</b>					
<b>NOMINAL CASE SIZE Ø D x L</b>	<b>Ø D<sub>max.</sub></b>	<b>L<sub>max.</sub></b>	<b>MASS (g)</b>	<b>PACKAGING QUANTITIES (units per box)</b>	<b>CARDBOARD BOX DIMENSIONS L x W x H</b>
20 x 25	21	27	≈ 10	104	310 x 200 x 42
22 x 25	23	27	≈ 11	84	310 x 200 x 42
22 x 30	23	32	≈ 15	84	310 x 200 x 47
22 x 35	23	37	≈ 17	84	310 x 200 x 52
22 x 40	23	42	≈ 19	84	310 x 200 x 57
25 x 25	26	27	≈ 15	66	310 x 200 x 42
25 x 30	26	32	≈ 18	66	310 x 200 x 47
25 x 35	26	37	≈ 20	66	310 x 200 x 52
25 x 40	26	42	≈ 27	66	310 x 200 x 57
25 x 50	26	52	≈ 28	66	310 x 200 x 67
30 x 30	31	32	≈ 32	45	310 x 200 x 47
30 x 35	31	37	≈ 35	45	310 x 200 x 52
30 x 40	31	42	≈ 37	45	310 x 200 x 57
30 x 50	31	52	≈ 42	45	310 x 200 x 67
35 x 25	36	27	≈ 32	40	310 x 200 x 42
35 x 30	36	32	≈ 38	40	310 x 200 x 47
35 x 35	36	37	≈ 43	40	310 x 200 x 52
35 x 40	36	42	≈ 50	40	310 x 200 x 57
35 x 45	36	47	≈ 57	40	310 x 200 x 62

<b>ELECTRICAL DATA</b>	
<b>SYMBOL</b>	<b>DESCRIPTION</b>
C <sub>R</sub>	Rated capacitance at 120 Hz, +20 °C
I <sub>R</sub>	Rated RMS ripple current at 120 Hz, +105 °C
I <sub>L5</sub>	Max. leakage current after 5 min at U <sub>R</sub>
ESR	Max. equivalent series resistance at 120 Hz, +20 °C

**Notes**

- Unless otherwise specified, all electrical values in Table 2 apply at T<sub>amb</sub> = 20 °C, P = 86 kPa to 106 kPa, RH = 45 % to 75 %

**ORDERING EXAMPLE**

Aluminum electrolytic capacitor 256 series;  
 4700 µF / 63 V;  
 2-terminal snap-in: MAL225638472E3



Table 2

ELECTRICAL DATA AND ORDERING INFORMATION								
U <sub>R</sub> (V)	C <sub>R</sub> (µF)	CASE SIZE Ø D x L (mm)	I <sub>R</sub> 120 Hz +105 °C (A)	tan δ 120 Hz +20 °C	TYP. ESR 120 Hz +20 °C <sup>(1)</sup> (Ω)	MAX. ESR 120 Hz +20 °C <sup>(1)</sup> (Ω)	I <sub>L</sub> 5 min (mA)	ORDERING CODE
16	10 000	20 x 25	1.61	0.50	0.047	0.066	1.20	MAL225615103E3
	15 000	22 x 30	2.20	0.50	0.031	0.044	1.47	MAL225625153E3
	22 000	25 x 30	2.77	0.50	0.021	0.030	1.50	MAL225635223E3
	33 000	30 x 30	3.48	0.50	0.014	0.020	1.50	MAL225645333E3
	47 000	35 x 35	4.85	0.50	0.010	0.014	1.50	MAL225655473E3
25	8200	22 x 25	1.73	0.45	0.040	0.073	1.36	MAL225626822E3
	15 000	22 x 40	2.65	0.45	0.022	0.040	1.50	MAL225626153E3
	22 000	25 x 40	3.22	0.45	0.015	0.027	1.50	MAL225636223E3
	22 000	30 x 30	3.18	0.45	0.015	0.027	1.50	MAL225646223E3
35	3300	22 x 25	1.31	0.40	0.074	0.161	1.02	MAL225620332E3
	4700	22 x 25	1.63	0.40	0.053	0.113	1.22	MAL225620472E3
	6800	25 x 30	2.04	0.40	0.037	0.078	1.46	MAL225630682E3
	10 000	30 x 30	2.75	0.40	0.027	0.053	1.50	MAL225640103E3
	22 000	35 x 40	4.69	0.40	0.013	0.024	1.50	MAL225650223E3
50	2200	22 x 25	1.48	0.35	0.088	0.211	0.99	MAL225621222E3
	2700	22 x 25	1.53	0.35	0.072	0.172	1.10	MAL225621272E3
	3300	22 x 30	1.76	0.35	0.059	0.141	1.22	MAL225621332E3
	3900	22 x 35	1.97	0.35	0.050	0.119	1.32	MAL225621392E3
	4700	25 x 30	2.18	0.35	0.042	0.099	1.45	MAL225631472E3
	6800	25 x 40	2.92	0.35	0.030	0.068	1.50	MAL225631682E3
10 000	30 x 40	3.55	0.35	0.022	0.046	1.50	MAL225641103E3	
63	1200	22 x 25	1.19	0.30	0.118	0.332	0.82	MAL225628122E3
	2200	22 x 30	1.55	0.30	0.069	0.181	1.12	MAL225628222E3
	2200	25 x 25	1.60	0.30	0.069	0.181	1.12	MAL225638222E3
	3300	25 x 35	2.06	0.30	0.049	0.121	1.37	MAL225638332E3
	4700	25 x 40	2.51	0.30	0.038	0.085	1.50	MAL225638472E3
	4700	30 x 30	2.48	0.30	0.038	0.085	1.50	MAL225648472E3
	6800	35 x 30	3.30	0.30	0.028	0.059	1.50	MAL225658682E3
	10 000	35 x 40	3.90	0.30	0.020	0.040	1.50	MAL225658103E3
80	1500	22 x 35	1.48	0.25	0.081	0.221	1.04	MAL225622152E3
	2200	25 x 30	1.65	0.25	0.056	0.151	1.26	MAL225632222E3
	3300	35 x 25	2.30	0.25	0.040	0.101	1.50	MAL225652332E3
	4700	35 x 30	2.64	0.25	0.030	0.071	1.50	MAL225652472E3
	5600	35 x 45	3.39	0.25	0.026	0.059	1.50	MAL225652562E3
	6800	35 x 40	3.56	0.25	0.022	0.049	1.50	MAL225652682E3
100	820	22 x 30	1.14	0.20	0.100	0.324	0.86	MAL225629821E3
	1200	25 x 30	1.56	0.20	0.072	0.221	1.04	MAL225639122E3
	2200	25 x 40	2.15	0.20	0.044	0.121	1.41	MAL225639222E3
	2700	30 x 35	2.37	0.20	0.036	0.098	1.50	MAL225649272E3
	3300	30 x 40	2.77	0.20	0.030	0.080	1.50	MAL225649332E3
	4700	35 x 40	3.30	0.20	0.023	0.056	1.50	MAL225659472E3
	5600	35 x 45	3.51	0.20	0.020	0.047	1.50	MAL225659562E3

Note

<sup>(1)</sup> ESR at 100 Hz is approximately 1.05 x ESR 120 Hz

ADDITIONAL ELECTRICAL DATA		
PARAMETER	CONDITIONS	VALUE
<b>Voltage</b>		
Surge voltage	at +85 °C	U <sub>S</sub> = 1.25 x U <sub>R</sub>
Reverse voltage	at +105 °C	U <sub>rev</sub> ≤ 1 V
<b>Inductance</b>		
Equivalent series inductance (ESL)	All case sizes	Typ. 19 nH
		Max. 25 nH



**RIPPLE CURRENT AND USEFUL LIFE**

Table 3

ENDURANCE TEST DURATION AND USEFUL LIFE	
ENDURANCE AT 105 °C (h)	USEFUL LIFE AT 105 °C (h)
2000	2000

**Note**

- Multiplier of useful life code: CCC208

CCC208

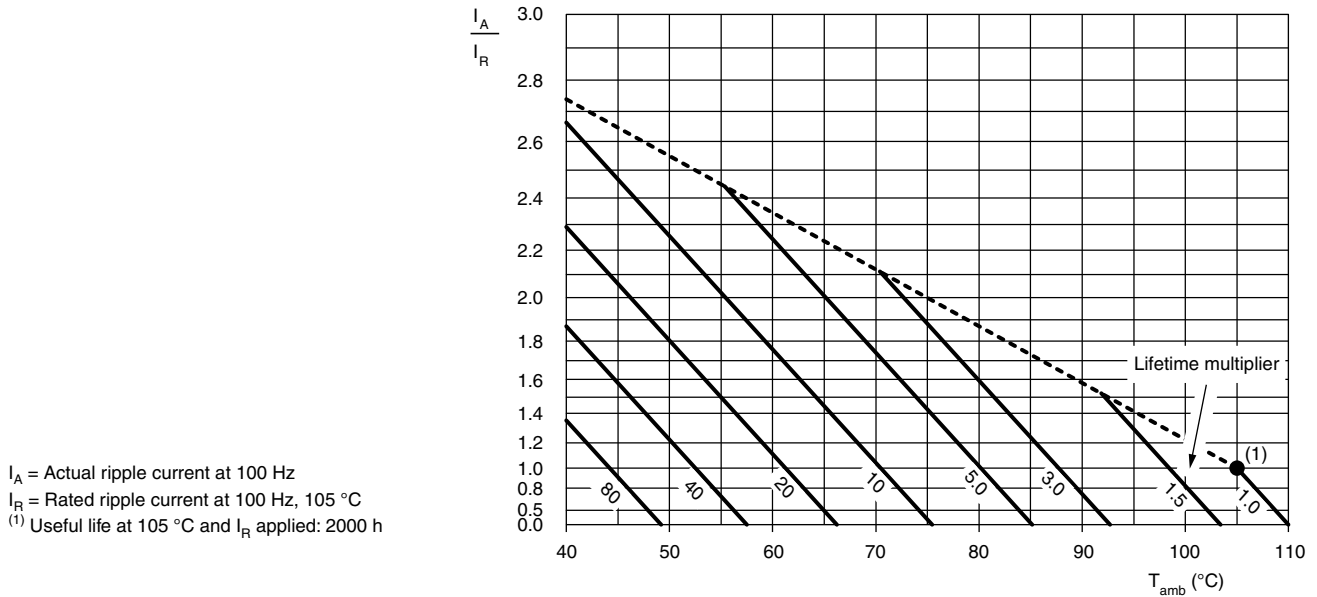

Fig. 4 - Multiplier of useful life as a function of ambient temperature and ripple current load

Table 4

MULTIPLIER OF RIPPLE CURRENT ( $I_R$ ) AS A FUNCTION OF FREQUENCY					
FREQUENCY (Hz)					
50	100	120	500	1000	≥ 10 000
$I_R$ MULTIPLIER					
0.92	0.95	1.00	1.13	1.19	1.20



Table 5

TEST PROCEDURES AND REQUIREMENTS			
TEST		PROCEDURE (quick reference)	REQUIREMENTS
NAME OF TEST	REFERENCE		
Endurance	IEC 60384-4 / EN130300 subclause 4.13	$T_{amb} = 105\text{ }^{\circ}\text{C}$ ; $U_R$ and $I_R$ applied; 2000 h	$\Delta C/C: \pm 20\%$ $\tan \delta \leq 2 \times \text{spec. limit}$ $I_{L5} \leq \text{spec. limit}$
Useful life	CECC 30301 subclause 4.13	$T_{amb} = 105\text{ }^{\circ}\text{C}$ ; $U_R$ and $I_R$ applied; 2000 h  $T_{amb} = 85\text{ }^{\circ}\text{C}$ ; $U_R$ and $I_R$ applied; > 5000 h	$\Delta C/C: \pm 20\%$ $\tan \delta \leq 2 \times \text{spec. limit}$ $I_{L5} \leq \text{spec. limit}$ no short or open circuit, no visible damage total failure percentage $\leq 1\%$
Shelf life (storage at high temperature)	IEC 60384-4 / EN130300 subclause 4.17	$T_{amb} = 105\text{ }^{\circ}\text{C}$ ; no voltage applied; 1000 h after test: $U_R$ to be applied for 30 min, 24 h to 48 h before measurement	$\Delta C/C: \pm 20\%$ $\tan \delta \leq 1.5 \times \text{spec. limit}$ $I_{L5} \leq 2 \times \text{spec. limit}$
Vibration	IEC 60384-4 / EN130300 subclause 4.8	10 Hz to 55 Hz; 0.037 m or 5 g (whichever is less); 3 axis; 2 h per axis	$\Delta C/C: \pm 10\%$ $\tan \delta \leq \text{spec. limit}$ $I_{L5} \leq \text{spec. limit}$

Statements about product lifetime are based on calculations and internal testing. They should only be interpreted as estimations. Also due to external factors, the lifetime in the field application may deviate from the calculated lifetime. In general, nothing stated herein shall be construed as a guarantee of durability.



## Disclaimer

ALL PRODUCT, PRODUCT SPECIFICATIONS AND DATA ARE SUBJECT TO CHANGE WITHOUT NOTICE TO IMPROVE RELIABILITY, FUNCTION OR DESIGN OR OTHERWISE.

Vishay Intertechnology, Inc., its affiliates, agents, and employees, and all persons acting on its or their behalf (collectively, "Vishay"), disclaim any and all liability for any errors, inaccuracies or incompleteness contained in any datasheet or in any other disclosure relating to any product.

Vishay makes no warranty, representation or guarantee regarding the suitability of the products for any particular purpose or the continuing production of any product. To the maximum extent permitted by applicable law, Vishay disclaims (i) any and all liability arising out of the application or use of any product, (ii) any and all liability, including without limitation special, consequential or incidental damages, and (iii) any and all implied warranties, including warranties of fitness for particular purpose, non-infringement and merchantability.

Statements regarding the suitability of products for certain types of applications are based on Vishay's knowledge of typical requirements that are often placed on Vishay products in generic applications. Such statements are not binding statements about the suitability of products for a particular application. It is the customer's responsibility to validate that a particular product with the properties described in the product specification is suitable for use in a particular application. Parameters provided in datasheets and / or specifications may vary in different applications and performance may vary over time. All operating parameters, including typical parameters, must be validated for each customer application by the customer's technical experts. Product specifications do not expand or otherwise modify Vishay's terms and conditions of purchase, including but not limited to the warranty expressed therein.

Hyperlinks included in this datasheet may direct users to third-party websites. These links are provided as a convenience and for informational purposes only. Inclusion of these hyperlinks does not constitute an endorsement or an approval by Vishay of any of the products, services or opinions of the corporation, organization or individual associated with the third-party website. Vishay disclaims any and all liability and bears no responsibility for the accuracy, legality or content of the third-party website or for that of subsequent links.

Except as expressly indicated in writing, Vishay products are not designed for use in medical, life-saving, or life-sustaining applications or for any other application in which the failure of the Vishay product could result in personal injury or death. Customers using or selling Vishay products not expressly indicated for use in such applications do so at their own risk. Please contact authorized Vishay personnel to obtain written terms and conditions regarding products designed for such applications.

No license, express or implied, by estoppel or otherwise, to any intellectual property rights is granted by this document or by any conduct of Vishay. Product names and markings noted herein may be trademarks of their respective owners.