



SIOV metal oxide varistors

Leaded varistors, StandarD, S07 compact series

Series/Type: SIOV-S07K***K11

Ordering code: B72307S0***

Date: September 2020

Version: 2

Construction

- Round varistor element, leaded
- Coating: epoxy resin, flame-retardant to UL 94 V-0
- Terminals: tinned wire

Features

- High performance with smaller disk diameter
- Wide operating voltage range 115 ... 460 V_{RMS}
- High surge current ratings up to 1200 A
- No derating up to 105°C ambient temperature
- PSpice models

Approvals

- UL
- CSA
- VDE
- IEC

Delivery mode

- Bulk (standard), taped versions on reel or in Ammo pack upon request
- For further details refer to chapter "Taping, packaging and lead configuration" for leaded varistors.

General technical data

Climatic category	to IEC 60068-1	40/105/56	
Operating temperature	to IEC 61051	-40 ... +105	°C
Storage temperature		-40 ... +125	°C
Electric strength	to IEC 61051	≥ 2.5	kV _{RMS}
Insulation resistance	to IEC 61051	≥ 100	MΩ

Electrical specifications and ordering codes

 Maximum ratings ($T_A = 105\text{ °C}$)

Ordering code	Type (untaped) SIOV-	V_{RMS} [V]	V_{DC} [V]	i_{max} (8/20 μ s) 1 time [A]*	$I_n^{(1)}$ (8/20 μ s) 15 times [A]*	W_{max} (2 ms) 1 time [J]	P_{max} [W]
B72307S0111K101	S07K115K11	115	150	1200	500	8.4	0.25
B72307S0131K101	S07K130K11	130	170	1200	500	9.5	0.25
B72307S0141K101	S07K140K11	140	180	1200	500	10.0	0.25
B72307S0151K101	S07K150K11	150	200	1200	500	11.0	0.25
B72307S0171K101	S07K175K11	175	225	1200	500	13.0	0.25
B72307S0211K101	S07K210K11	210	270	1200	500	15.0	0.25
B72307S0231K101	S07K230K11	230	300	1200	500	17.0	0.25
B72307S0251K101	S07K250K11	250	320	1200	500	19.0	0.25
B72307S0271K101	S07K275K11	275	350	1200	500	21.0	0.25
B72307S0301K101	S07K300K11	300	385	1200	500	23.0	0.25
B72307S0321K101	S07K320K11	320	420	1200	500	25.0	0.25
B72307S0351K101	S07K350K11	350	460	1200	500	27.0	0.25
B72307S0381K101	S07K385K11	385	505	1200	500	28.0	0.25
B72307S0421K101	S07K420K11	420	560	1200	500	32.0	0.25
B72307S0441K101	S07K440K11	440	585	1200	500	34.0	0.25
B72307S0461K101	S07K460K11	460	615	1200	500	36.0	0.25

¹⁾ **Note:** Nominal discharge current is the specification defined in UL1449 4th edition and tested with 8/20 μ s current waveform

Characteristics ($T_A=25\text{ °C}$):

Ordering code	Type (untaped) SIOV-	V_v (1 mA) [V]	ΔV_v (1 mA) [%]	Max clamping voltage		C_{typ} (1 kHz) [pF]
				V_c [V]	I_c [A]	
B72307S0111K101	S07K115K11	180	± 10	300	10	280
B72307S0131K101	S07K130K11	205	± 10	340	10	245
B72307S0141K101	S07K140K11	220	± 10	360	10	230
B72307S0151K101	S07K150K11	240	± 10	395	10	210
B72307S0171K101	S07K175K11	270	± 10	455	10	190
B72307S0211K101	S07K210K11	330	± 10	550	10	140
B72307S0231K101	S07K230K11	360	± 10	595	10	130
B72307S0251K101	S07K250K11	390	± 10	650	10	120
B72307S0271K101	S07K275K11	430	± 10	710	10	110
B72307S0301K101	S07K300K11	470	± 10	775	10	100
B72307S0321K101	S07K320K11	510	± 10	840	10	90
B72307S0351K101	S07K350K11	560	± 10	910	10	80
B72307S0381K101	S07K385K11	620	± 10	1025	10	85
B72307S0421K101	S07K420K11	680	± 10	1120	10	75
B72307S0441K101	S07K440K11	715	± 10	1180	10	72
B72307S0461K101	S07K460K11	750	± 10	1240	10	70

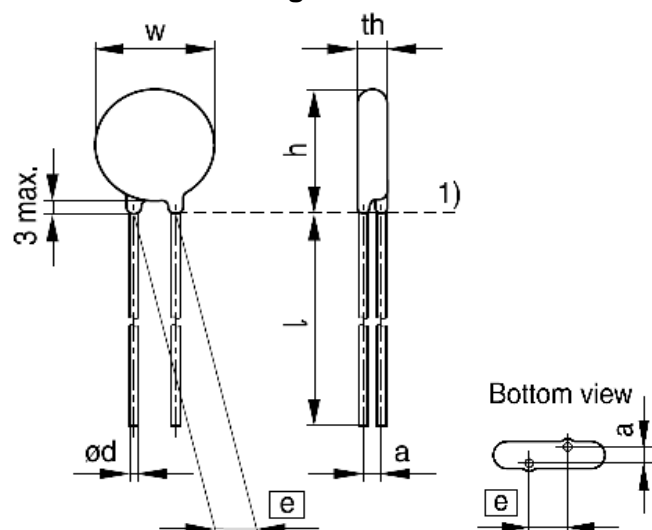
Dimensional drawings

¹⁾Seating plane to IEC 60717

Weight

Nominal diameter mm	V _{RMS} V	Weight g
7	115...460	0.7...1.1

The weight of varistors in between these voltage classes can be interpolated.

Dimensions

Ordering code ²⁾	[e] ±1 mm	W _{max} mm	h _{max} mm	th _{max} mm	a _{typ} mm	l _{min} mm	Ød±0.05 mm
B72307S0111K101	5.0	8.5	10.5	3.6	1.5	25.0	0.6
B72307S0131K101	5.0	8.5	10.5	3.6	1.6	25.0	0.6
B72307S0141K101	5.0	8.5	10.5	3.7	1.7	25.0	0.6
B72307S0151K101	5.0	8.5	10.5	3.8	1.8	25.0	0.6
B72307S0171K101	5.0	8.5	10.5	4.0	2.0	25.0	0.6
B72307S0231K101	5.0	8.5	10.5	4.0	1.5	25.0	0.6
B72307S0231K101	5.0	8.5	10.5	4.0	1.5	25.0	0.6
B72307S0251K101	5.0	8.5	10.5	4.2	1.5	25.0	0.6
B72307S0271K101	5.0	8.5	10.5	4.4	1.6	25.0	0.6
B72307S0301K101	5.0	8.5	10.5	4.5	1.7	25.0	0.6
B72307S0321K101	5.0	8.5	10.5	4.8	1.9	25.0	0.6
B72307S0351K101	5.0	8.5	10.5	4.9	2.0	25.0	0.6
B72307S0381K101	5.0	8.5	10.5	5.2	2.1	25.0	0.6
B72307S0421K101	5.0	8.5	10.5	5.4	2.4	25.0	0.6
B72307S0441K101	5.0	8.5	10.5	5.5	2.4	25.0	0.6
B72307S0461K101	5.0	8.5	10.5	5.7	2.6	25.0	0.6

²⁾ *May be suffix -V87: CCS wire for leads

Reliability data

Test	Test methods/conditions	Requirement
Varistor voltage	The voltage between two terminals with the specified measuring current applied is called V_V (1 mA _{DC} @ 0.2 ... 2 s).	To meet the specified value
Clamping voltage	The maximum voltage between two terminals with the specified standard impulse current (8/20 μ s) applied.	To meet the specified value
Endurance at upper category temperature	1000 h at UCT After having continuously applied the maximum allowable AC voltage at UCT ± 2 °C for 1000 h, the specimen shall be stored at room temperature and normal humidity for 1 to 2 h. Thereafter, the change of V_V shall be measured.	$ \Delta V/V (1 \text{ mA}) \leq 10\%$
Surge current derating, 8/20 μ s	10 surge currents (8/20 μ s), unipolar, interval 30 s, amplitude corresponding to derating curve for 10 impulses at 20 μ s	$ \Delta V/V (1 \text{ mA}) \leq 10\%$ (measured in direction of surge current) No visible damage
Surge current derating, 2 ms	10 surge currents (2 ms), unipolar, interval 120 s, amplitude corresponding to derating curve for 10 impulses at 2 ms	$ \Delta V/V (1 \text{ mA}) \leq 10\%$ (measured in direction of surge current) No visible damage
Electric strength	IEC 61051-1, test 4.9.2 Metal balls method, 2500 VRMS, 60 s The varistor is placed in a container holding 1.6 \pm 0.2 mm diameter metal balls such that only the terminations of the varistor are protruding. The specified voltage shall be applied between both terminals of the specimen connected together and the electrode inserted between the metal balls.	No breakdown

Test	Test methods/conditions	Requirement
Climatic sequence	<p>The specimen shall be subjected to:</p> <p>a) dry heat at UCT, 16 h, IEC 60068-2-2, test Ba</p> <p>b) damp heat, 1st cycle: 55 °C, 93% r. H., 24 h, IEC 60068-2-30, test Db</p> <p>c) cold, LCT, 2 h, IEC 60068-2-1, test Aa</p> <p>d) damp heat, additional 5 cycles: 55 °C/25 °C, 93% r. H., 24 h/cycle, IEC 60068-2-30, test Db.</p> <p>Then the specimen shall be stored at room temperature and normal humidity for 1 to 2 h.</p> <p>Thereafter, the change of V_V shall be measured. Thereafter, insulation resistance R_{ins} shall be measured at $V = 500 V$.</p>	$ \Delta V/V (1 mA) \leq 10\%$ $R_{ins} \geq 100 M\Omega$
Rapid change of temperature	IEC 60068-2-14, test Na, LCT/UCT, dwell time 30 min, 5 cycles	$ \Delta V/V (1 mA) \leq 5\%$ No visible damage
Damp heat, steady state	IEC 60068-2-78, test Ca The specimen shall be subjected to 40 ± 2 °C, 90 to 95% r. H. for 56 days without load / with 10% of the maximum continuous DC operating voltage VDC. Then stored at room temperature and normal humidity for 1 to 2 h. Thereafter, the change of V_V shall be measured. Thereafter, insulation resistance R_{ins} shall be measured at $V = 500 V$ (insulated varistors only).	$ \Delta V/V (1 mA) \leq 10\%$ $R_{ins} \geq 100 M\Omega$

Test	Test methods/conditions	Requirement
Solderability	IEC 60068-2-20, test Ta, method 1 with modified conditions for lead-free solder alloys: 245 °C, 3 s: After dipping the terminals to a depth of approximately 3 mm from the body in a soldering bath of 245 °C for 3 s, the terminals shall be visually examined.	The inspection shall be carried out under adequate light with normal eyesight or with the assistance of a magnifier capable of giving a magnification of 4 to 10 times. The dipped surface shall be covered with a smooth and bright solder coating with no more than small amounts of scattered imperfections such as pinholes or un-wetted or de-wetted areas. These imperfections shall not be concentrated in one area.
Resistance to soldering heat	IEC 60068-2-20, test Tb, method 1A, 260 °C, 10 s: Each lead shall be dipped into a solder bath having a temperature of 260 ±5 °C to a point 2.0 to 2.5 mm from the body of the specimen, be held there for 10 ±1 s and then be stored at room temperature and normal humidity for 1 to 2 h. The change of VV shall be measured and the specimen shall be visually examined.	$ \Delta V/V (1 \text{ mA}) \leq 5\%$ No visible damage
Tensile strength	IEC 60068-2-21, test Ua1 After gradually applying the force specified below and keeping the unit fixed for 10 s, the terminal shall be visually examined for any damage. Force for wire diameter: 0.6 mm = 10 N 0.8 mm = 10 N 1.0 mm = 20 N	$ \Delta V/V (1 \text{ mA}) \leq 5\%$ No break of solder joint, no wire break

Test	Test methods/conditions	Requirement
Vibration	IEC 60068-2-6, test Fc, method B4 Frequency range: 10 ... 55 Hz Amplitude: 0.75 mm or 98 m/s ² Duration: 6 h (3 · 2 h) Pulse: sine wave After repeatedly applying a single harmonic vibration according to the table above. The change of V _V shall be measured and the specimen shall be visually examined.	\ΔV/V (1 mA) ≤5% No visible damage
Bump	IEC 60068-2-29, test Eb Pulse duration: 6 ms Max. acceleration: 400 m/s ² Number of bumps: 4000 Pulse: half sine	\ΔV/V (1 mA) ≤5% No visible damage
Fire hazard	IEC 60695-11-5 (needle flame test) Severity: vertical 10 s	5 s max.

Note:

UCT = Upper category temperature

LCT = Lower category temperature

 R_{ins} = Insulation resistance

v/i characteristics

$v = f(i)$ - for explanation of the characteristics refer to "General technical information", 1.6.3

A = Leakage current, B = Protection level } for worst-case varistor tolerances

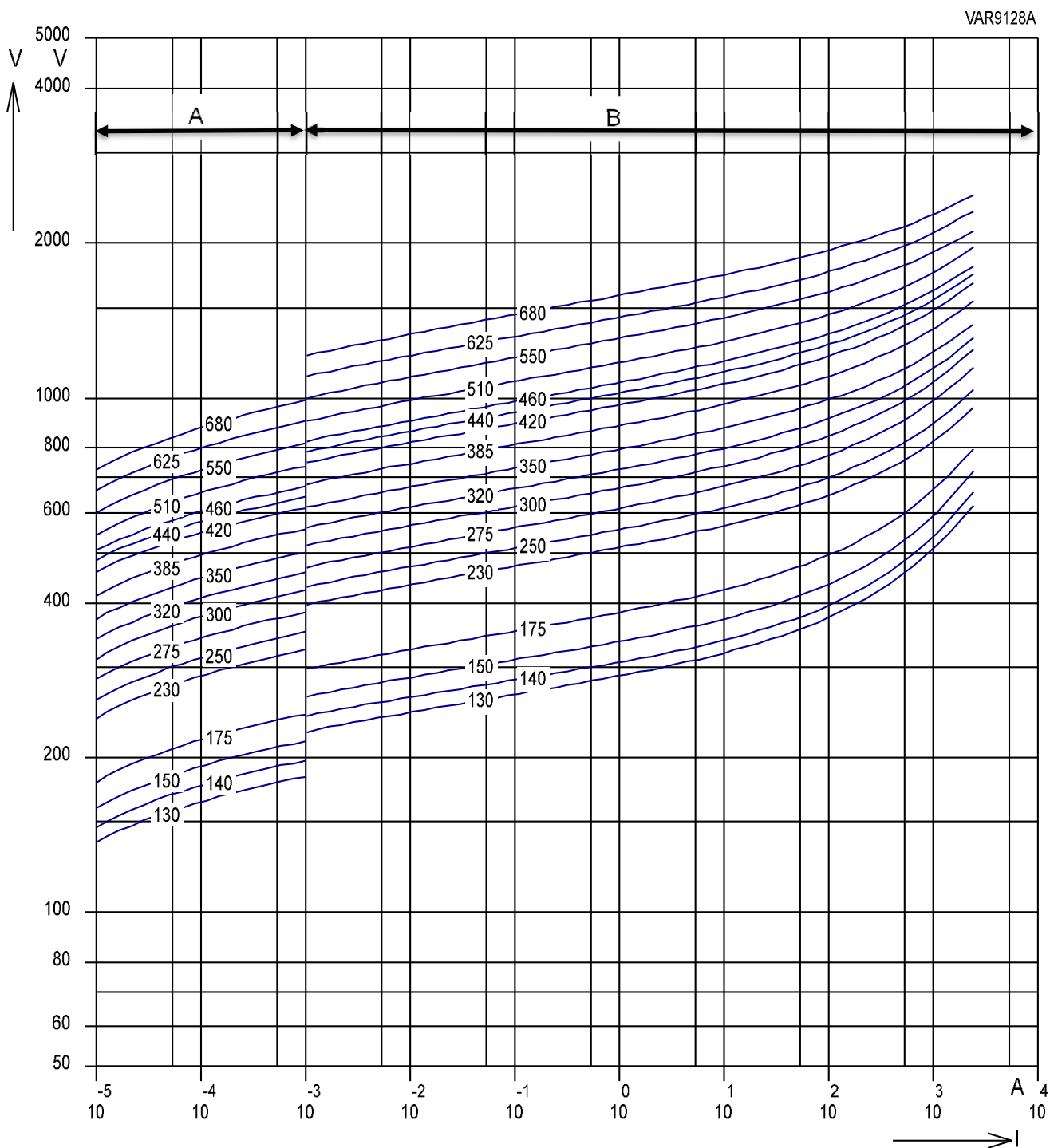

Derating curves

Maximum surge current $i_{max} = f(t_r, \text{pulse train})$

For explanation of the derating curves refer to "General technical information", section 1.8.1

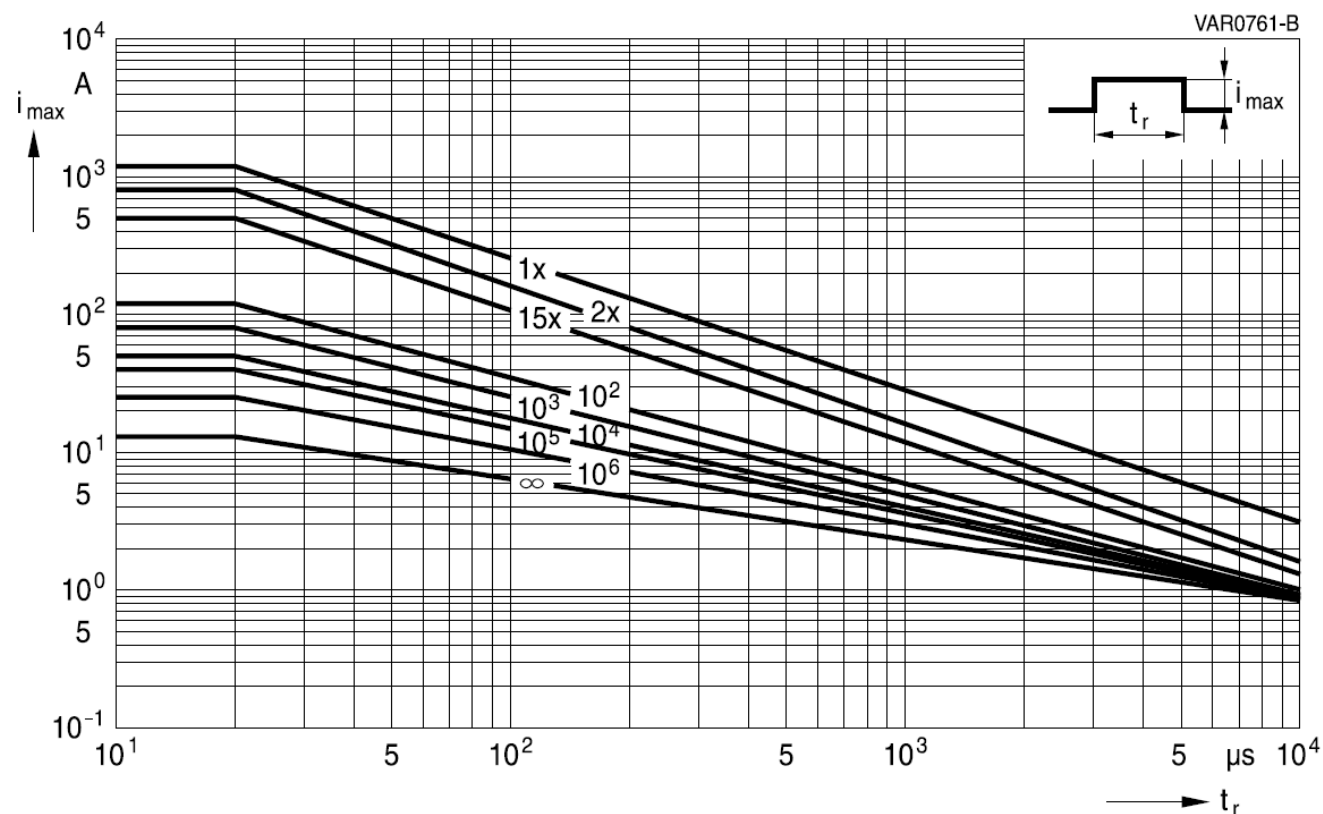

Taping, packaging and lead configuration

1 TDK Electronics ordering code system for leaded varistors

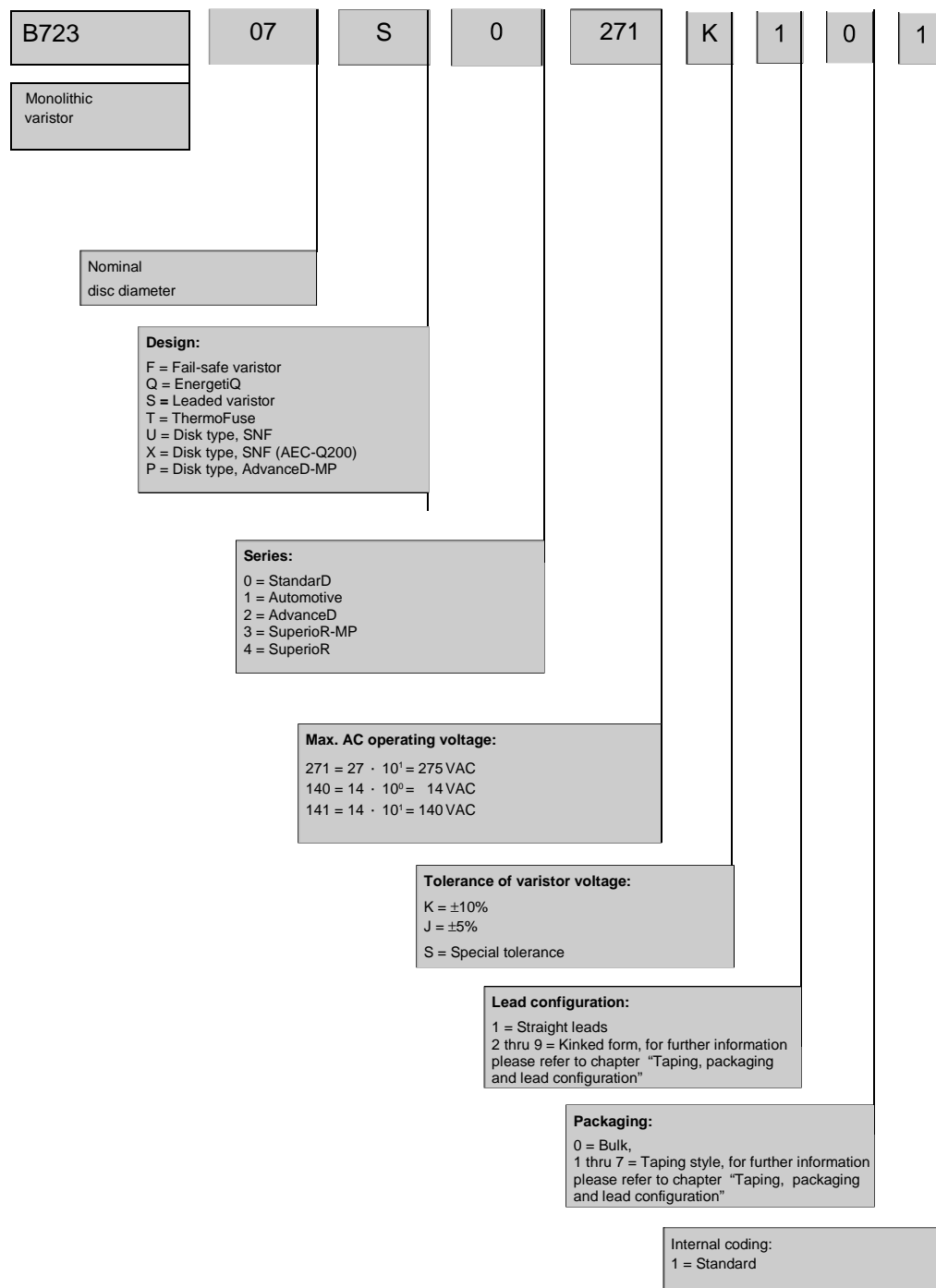

2 Taping and packaging of leaded varistors

Tape packaging for lead spacing \square = 5 fully conforms to IEC 60286-2, while for lead spacings \square = 7.5 and 10 the taping mode is based on this standard.

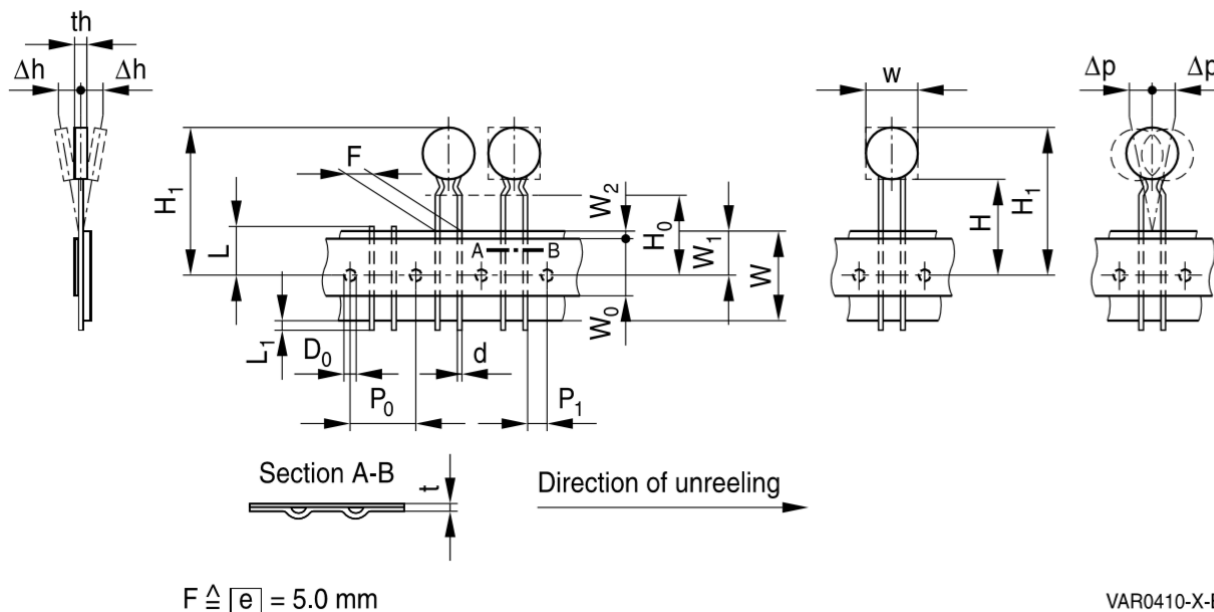

2.1 Taping in accordance with IEC 60286-2 for lead spacing 5.0 mm

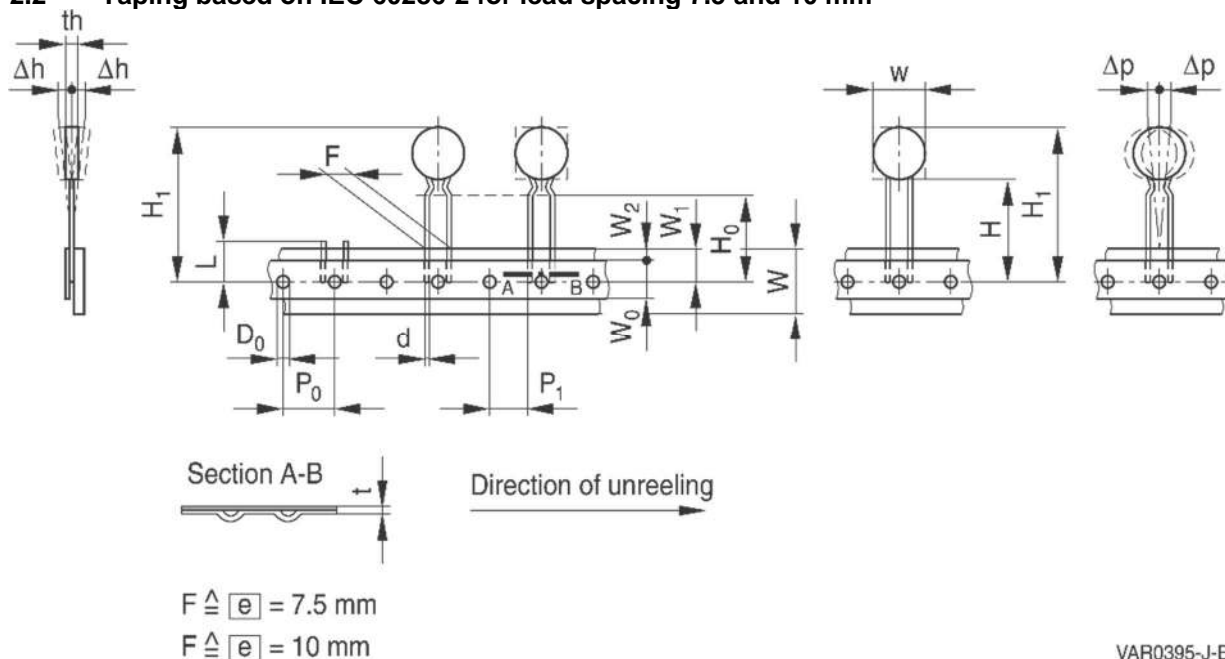

2.2 Taping based on IEC 60286-2 for lead spacing 7.5 and 10 mm



2.3 Tape dimensions (in mm)

Symbol	 = 5.0	Tolerance	 = 7.5	Tolerance	 = 10.0	Tolerance	Remarks
w th d	0.6	max. max. ±0.05	0.8	max. max. ±0.05	1.0	max. max. ±0.05	see tables in each series under "Dimensions "
P ₀	12.7	±0.3	12.7 ¹⁾	±0.3	12.7	±0.3	±1 mm/20 sprocket holes
P ₁	3.85	±0.7	8.95	±0.8	7.7	±0.8	
F	5.0	±10	7.5	±0.8	10.0	±0.8	
Δh	0	±2.0	depends on s	±2.0	depends on s	±2.0	measured at top of compo- nent body
Δp	0	±1.3	0		0		
W	18.0	±0.5	18.0	±0.5	18.0	±0.5	
W ₀	5.5	min.	11.0	min.	11.0	min.	Peel-off force ≥ 5 N
W ₁	9.0	±0.5	9.0	+0.75/-0.5	9.0	+0.75/-0.5	
W ₂	3.0	max.	3.0	max.	3.0	max.	
H	18.0	+2.0/-0	18.0	+2.0/-0	18.0	+2.0/-0	²⁾
H ₀	16.0	±0.5	16.0	±0.5	16.0	±0.5	³⁾
	(18.0)		(18.0)				
H ₁	32.2	max.	45.0	max.	45.0	max.	
D ₀	4.0	±0.2	4.0	±0.2	4.0	±0.2	
t	0.9	max.	0.9	max.	0.9	max.	without lead
L	11.0	max.	11.0	max.	11.0	max.	
L ₁	0.5	max.					

1) Taping with P₀ = 15.0 mm upon request

2) Applies only to uncrimped types

3) Applies only to crimped types (H₀ = 18 upon request)

2.4 Taping mode

Example: B72307S0271K1 51

Digit 14

Digit 14	Taping mode	Reel type	Seating plane height H_0 for crimped types mm	Seating plane height H for uncrimped types mm	Pitch distance P_0 mm
0	-	Bulk	-	-	-
1	G	I	16	18	12.7
2	G2	I	18	-	12.7
3	G3	II	16	18	12.7
4	G4	II	18	-	12.7
5	G5	III	16	18	12.7
6	GA	Ammo pack	16	18	12.7
7	G2A	Ammo pack	18	-	12.7
Internal coding for special taping					
	G6	III	18	-	12.7
	G10	II	16	18	15.0
	G11	II	18	-	15.0
	G10A	Ammo pack	16	18	15.0
	G11A	Ammo pack	18	-	15.0

2.5 Reel dimension

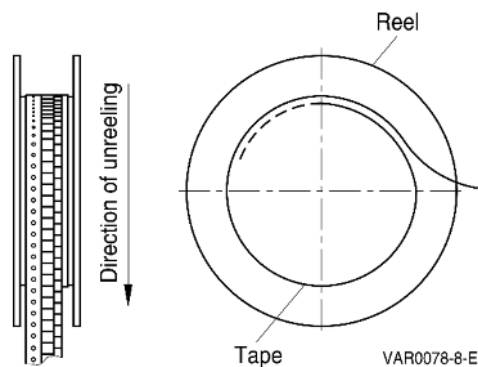
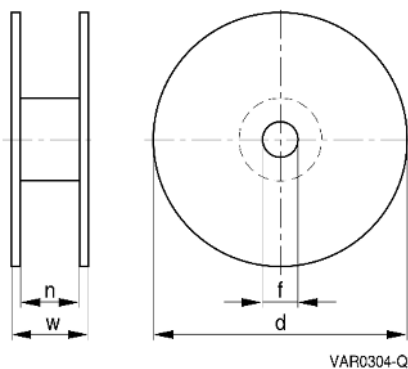

Dimensions (in mm)

Reel type	d	f	n	w
I	360 max.	31 ±1	approx. 45	54 max.
II	360 max.	31 ±1	approx. 55	64 max.
III	500 max.	23 ±1	approx. 59	72 max.

If reel type III is not compatible with insertion equipment because of its large diameter, nominal disk diameter 10 mm and 14 mm can be supplied on reel II upon request (taping mode G3).

2.6 Ammo pack dimensions

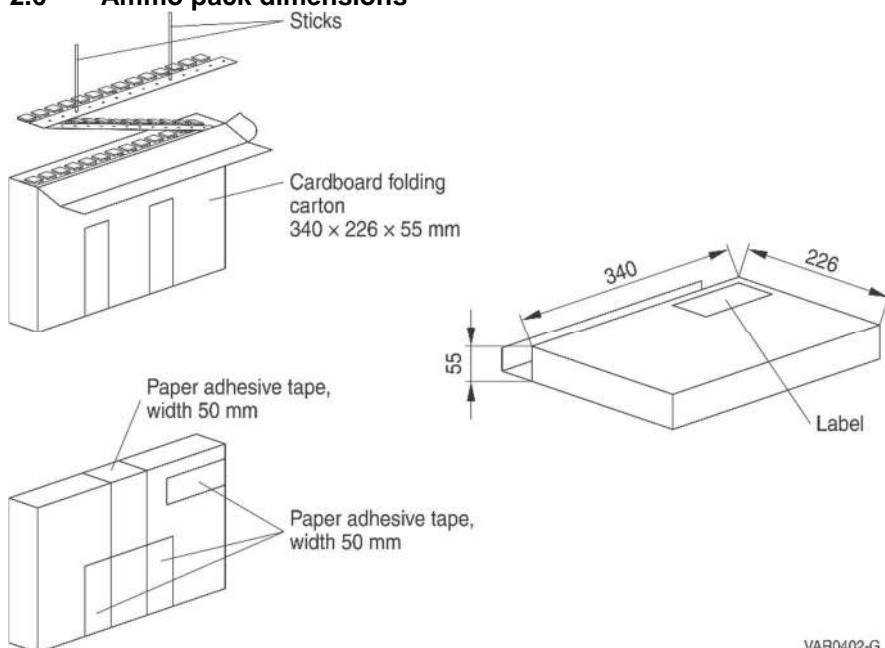

3 Lead configuration

Straight leads are standard for disk varistors. Other lead configurations as crimp style or customerspecific lead wire length according to 3.1, 3.2, 3.3 and 3.4 are optional. Crimped leads (non-standard) are differently crimped for technical reasons; the individual crimp styles are denoted by consecutive numbers (S, S2 through S5) as shown in the dimensional drawings below.

The crimp styles of the individual types can be seen from the type designation in the ordering tables.

3.1 Crimp style mode

Example: B72307S0271K 5 01
|
Digit 13

Digit 13 of ordering code	Crimp style	Figure
1	Standard, straight leads	1
2	S2	2
3	S3	3
5	S5	4

3.2 Standard leads and non-standard crimp styles

The basic dimensions in figure 1 to 5 are valid for types with either round or square (EnergetiQ series) component head.

Standard, straight leads

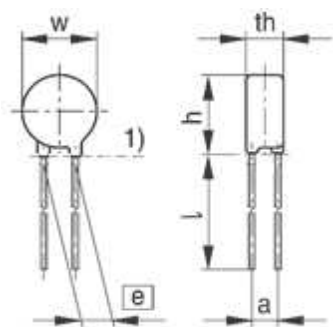

1) Seating plane to IEC 717
VAR0586-W-E

Figure 1

Non-standard, crimp style S2

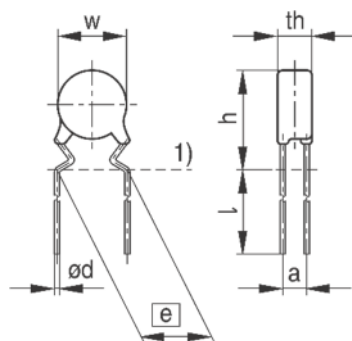

1) Seating plane to IEC 60717
VAR0411-F-E

Figure 2

Non-standard, crimp style S3

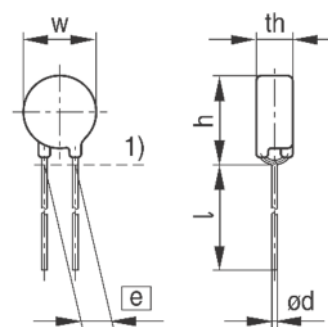

1) Seating plane to IEC 60717
VAR0396-R-E

Figure 3

Non-standard, crimp style S5

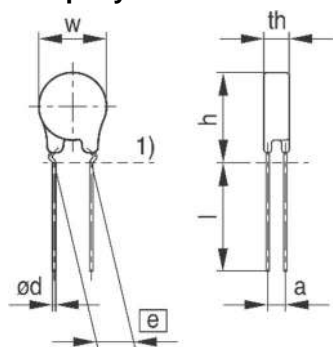

1) Seating plane to IEC 60717
VAR0726-M-E

Figure 4

3.3 Trimmed leads (non-standard)

Varistors with cut leads available upon request.

Lead length tolerances:

Straight leads ± 0.8 mm

Crimped leads ± 0.5 mm

Minimum lead length 3.0 mm

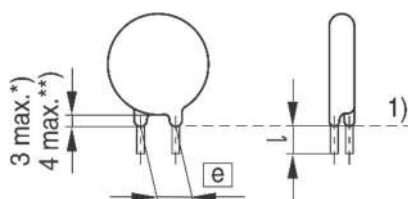

1) Seating plane to IEC 60717

*) For round component head

***) For EnergetiQ series, square component head

VAR0642-U-E

Cautions and warnings

General

1. TDK Electronics metal oxide varistors (SIOVs) are designed for specific applications and should not be used for purposes not identified in our specifications, application notes and data books unless otherwise agreed with TDK Electronics during the design-in-phase.
2. Ensure suitability of SIOVs through reliability testing during the design-in phase. The SIOVs should be evaluated taking into consideration worst-case conditions.
3. For applications of SIOVs in line-to ground circuits based on various international and local standards there are restrictions existing or additional safety measures required.

Storage

1. Store SIOVs only in original packaging. Do not open the package prior to processing.
2. Recommended storage conditions in original packaging:

Storage temperature:	-25 °C ... +45 °C
Relative humidity:	<75% annual average, <95% on maximum 30 days a year.
Dew precipitation:	Is to be avoided.
3. Avoid contamination of an SIOV's during storage, handling and processing.
4. Avoid storage of SIOVs in harmful environments that can affect the function during long-term operation (examples given under operation precautions).
5. The SIOV type series should be soldered after shipment from TDK Electronics within the time specified.

SIOV-S, -Q, -LS, -B, -SNF	24 months
ETFV/ T series, -CU	12 months.

Handling

1. SIOVs must not be dropped.
2. Components must not be touched with bare hands. Gloves are recommended.
3. Avoid contamination of the surface of SIOV electrodes during handling, be careful of the sharp edge of SIOV electrodes.

Soldering (where applicable)

1. Use rosin-type flux or non-activated flux.
2. Insufficient preheating may cause ceramic cracks.

3. Rapid cooling by dipping in solvent is not recommended.
4. Complete removal of flux is recommended.
5. Temperatures of all preheat stages and the solder bath must be strictly controlled especially for T series (T14 and T20).

Mounting

1. Potting, sealing or adhesive compounds can produce chemical reactions in the SIOV ceramic that will degrade the component's electrical characteristics.
2. Overloading SIOVs may result in ruptured packages and expulsion of hot materials. For this reason the SIOVs should be physically shielded from adjacent components.

Operation

1. Use SIOVs only within the specified temperature operating range
2. Use SIOVs only within the specified voltage and current ranges.
3. Environmental conditions must not harm the SIOVs. Use SIOVs only in normal atmospheric conditions. Avoid use in the presence of deoxidizing gases (chlorine gas, hydrogen sulfide gas, ammonia gas, sulfuric acid gas, etc), corrosive agents, humid or salty conditions, Avoid contact with any liquids and solvents.

Symbols and terms

Symbol	Term
C	Capacitance
C_{typ}	Typical capacitance
i	Current
i_c	Current at which $V_{c,max}$ is measured
I_{leak}	Leakage current
i_{max}	Maximum surge current (also termed peak current)
I_{max}	Maximum discharge current
I_n	Nominal discharge current to UL 1449
LCT	Lower category temperature
L_{typ}	Typical inductance
P_{max}	Maximum average power dissipation
R_{ins}	Insulation resistance
R_{min}	Minimum resistance
T_A	Ambient temperature
t_r	Duration of equivalent rectangular wave
UCT	Upper category temperature
v	Voltage
V_{clamp}	Clamping voltage
$V_{c,max}$	Maximum clamping voltage at specified current i_c DC operating voltage
V_{DC}	Maximum jump start voltage
V_{jump}	Maximum voltage
V_{max}	Operating voltage
V_{op}	AC operating voltage, root-mean-square value
V_{RMS}	Root-mean-square value of max. DC operating voltage incl. ripple current
$V_{RMS,op,max}$	Super imposed surge voltage
V_{surge}	Varistor voltage
V_V	Tolerance of varistor voltage
ΔV_V	Maximum load dump
W_{LD}	Maximum energy absorption
W_{max}	Maximum energy absorption
	Lead spacing

All dimensions are given in mm.

The commas used in numerical values denote decimal points.

Display of ordering codes for TDK Electronics products

The ordering code for one and the same product can be represented differently in data sheets, data books, other publications, on the company website, or in order-related documents such as shipping notes, order confirmations and product labels. **The varying representations of the ordering codes are due to different processes employed and do not affect the specifications of the respective products.** Detailed information can be found on the Internet under www.tdk-electronics.tdk.com/orderingcodes.

Important notes

The following applies to all products named in this publication:

1. Some parts of this publication contain **statements about the suitability of our products for certain areas of application**. These statements are based on our knowledge of typical requirements that are often placed on our products in the areas of application concerned. We nevertheless expressly point out **that such statements cannot be regarded as binding statements about the suitability of our products for a particular customer application**. As a rule we are either unfamiliar with individual customer applications or less familiar with them than the customers themselves. For these reasons, it is always ultimately incumbent on the customer to check and decide whether a product with the properties described in the product specification is suitable for use in a particular customer application.
2. We also point out that **in individual cases, a malfunction of electronic components or failure before the end of their usual service life cannot be completely ruled out in the current state of the art, even if they are operated as specified**. In customer applications requiring a very high level of operational safety and especially in customer applications in which the malfunction or failure of an electronic component could endanger human life or health (e.g. in accident prevention or life-saving systems), it must therefore be ensured by means of suitable design of the customer application or other action taken by the customer (e.g. installation of protective circuitry or redundancy) that no injury or damage is sustained by third parties in the event of malfunction or failure of an electronic component.
3. **The warnings, cautions and product-specific notes must be observed.**
4. In order to satisfy certain technical requirements, **some of the products described in this publication may contain substances subject to restrictions in certain jurisdictions (e.g. because they are classed as hazardous)**. Useful information on this will be found in our Material Data Sheets on the Internet (www.tdk-electronics.tdk.com/material). Should you have any more detailed questions, please contact our sales offices.
5. We constantly strive to improve our products. Consequently, **the products described in this publication may change from time to time**. The same is true of the corresponding product specifications. Please check therefore to what extent product descriptions and specifications contained in this publication are still applicable before or when you place an order.

We also **reserve the right to discontinue production and delivery of products**. Consequently, we cannot guarantee that all products named in this publication will always be available. The aforementioned does not apply in the case of individual agreements deviating from the foregoing for customer-specific products.

6. Unless otherwise agreed in individual contracts, **all orders are subject to our General Terms and Conditions of Supply**.
7. **Our manufacturing sites serving the automotive business apply the IATF 16949 standard**. The IATF certifications confirm our compliance with requirements regarding the quality management system in the automotive industry. Referring to customer requirements and customer specific requirements ("CSR") TDK always has and will continue to have the policy of respecting individual agreements. Even if IATF 16949 may appear to support the acceptance of unilateral requirements, we hereby like to emphasize that **only requirements mutually agreed upon can and will be implemented in our Quality Management System**. For clarification purposes we like to point out that obligations from IATF 16949 shall only become legally binding if individually agreed upon.

Important notes

8. The trade names EPCOS, CarXield, CeraCharge, CeraDiode, CeraLink, CeraPad, CeraPlas, CSMP, CTVS, DeltaCap, DigiSiMic, ExoCore, FilterCap, FormFit, LeaXield, MiniBlue, MiniCell, MKD, MKK, ModCap, MotorCap, PCC, PhaseCap, PhaseCube, PhaseMod, PhiCap, PowerHap, PQSine, PQvar, SIFERRIT, SIFI, SIKOREL, SilverCap, SIMDAD, SiMic, SIMID, SineFormer, SIOV, ThermoFuse, WindCap, XieldCap are **trademarks registered or pending** in Europe and in other countries. Further information will be found on the Internet at www.tdk-electronics.tdk.com/trademarks.

Release 2020-06