

© COPYRIGHT 1968 BY AMP INCORPORATED, HARRISBURG, PA.
 ALL INTERNATIONAL RIGHTS RESERVED. AMP INCORPORATED PRODUCTS
 COVERED BY U. S. AND FOREIGN PATENTS AND/OR PATENTS PENDING.

REVISIONS						
P	F	ZONE	LTR	DESCRIPTION	DATE	APPROVED
✓	✓		AA	OBsolete -2 PER CM 2215	4-3-89	1B/RS

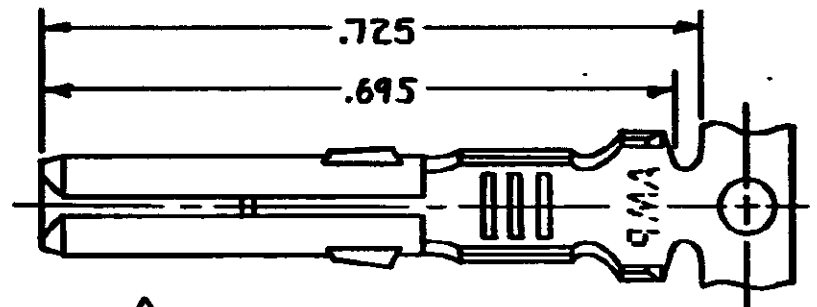

POINT OF MEASUREMENT
 (INSIDE OF RECEPTACLE)

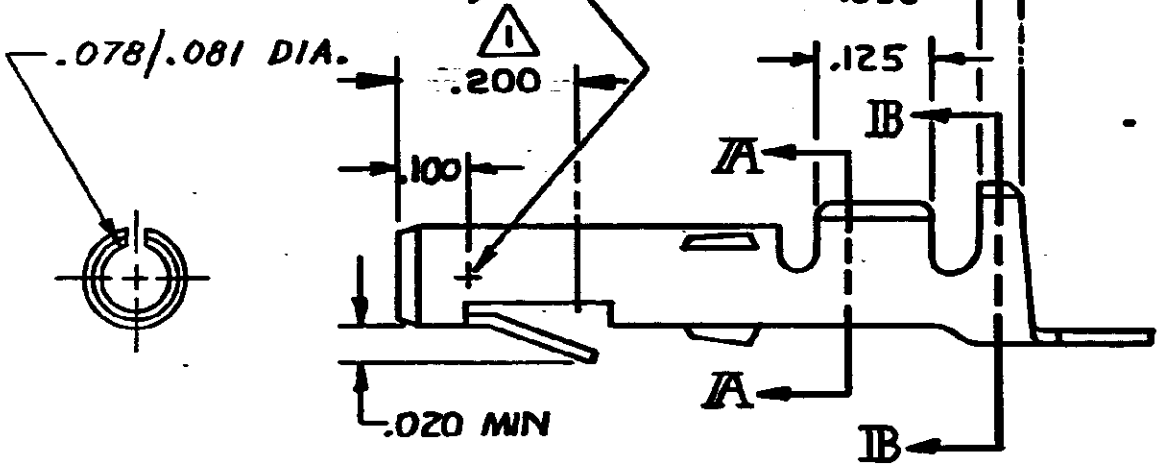

▲ NICKEL PLATED ON ENTIRE TERMINAL, .000030
 GOLD OVER INSIDE OF MATING AREA AND WIRE
 BARREL.

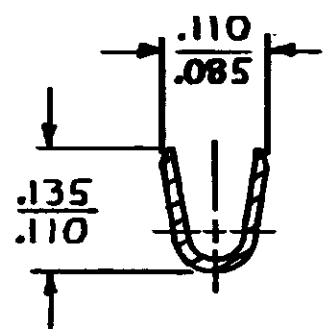

SECTION A-A

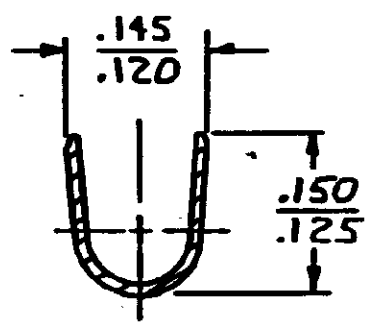

SECTION B-B

GOLD ▲	.010 BRASS	6115-5
PRE-TIN	.010 BRASS	6115-1
FINISH	MATERIAL	PART NO

UNLESS OTHERWISE SPECIFIED DIMENSIONS ARE IN INCHES. TOLERANCES ON DECIMALS ±.015 ANGLES ±	CONTRACT NO	AMP INCORPORATED Harrisburg, Pa.	
	OR M. FEHER 11-30-79		
MATERIAL SEE TABLE	CHK D.S. Heide 12/11/79	NAME SOCKET, COMMERCIAL MATE-N-LOK	
	APPD W. V. Schmitt 12/12/79		
FINISH SEE TABLE	WIRE RANGE .24-18 AWG	SIZE B	CODE IDENT NO 00779
	INSULATION DIA .100 MAX	DRAWING NO 6115	
		SCALE 5-1	SHEET