

LMS33460 3-V Undervoltage Detector

1 Features

- Ultra-Low Power
- 3-V Detection
- Input Voltage From 0.8 V to 7 V
- Open-Drain Output
- Ultra-Small 5-Pin SC70 Package
- Extended Temperature Range (–40°C to 85°C)
- Ultra-Low Quiescent Current (1 μ A Typical)

2 Applications

- Low Battery Voltage Detectors
- Power Fail Indicators
- Processor Reset Generators
- Battery Backup Controls
- Battery-Operated Equipment
- Hand-Held Instruments
- Undervoltage Detectors

3 Description

The LMS33460 device is an undervoltage detector with a 3-V threshold and extremely low power consumption. The LMS33460 is specifically designed to accurately monitor power supplies. It is especially suited to battery-powered systems where low quiescent current and small size are required. This IC generates an active output whenever the input voltage drops below 3 V.

This part uses a precision on-chip voltage reference and a comparator to measure the input voltage. Built-in hysteresis helps to prevent erratic operation in the presence of noise. The UVD is available in the ultra-miniature 5-pin SC70 package.

Device Information⁽¹⁾

PART NUMBER	PACKAGE	BODY SIZE (NOM)
LMS33460	SC70 (5)	2.00 mm × 1.25 mm

(1) For all available packages, see the orderable addendum at the end of the data sheet.

Typical Application

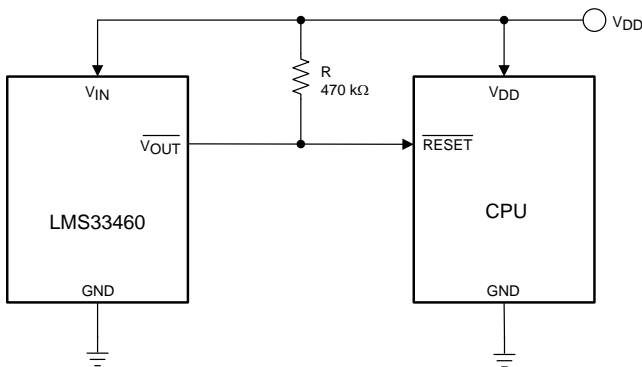

Copyright © 2016, Texas Instruments Incorporated

SC70 Package



Table of Contents

1 Features 1 2 Applications 1 3 Description 1 4 Revision History 2 5 Pin Configuration and Functions 3 6 Specifications 3 6.1 Absolute Maximum Ratings 3 6.2 ESD Ratings..... 3 6.3 Recommended Operating Conditions 3 6.4 Thermal Information 4 6.5 Electrical Characteristics..... 4 6.6 Typical Characteristics 5 7 Detailed Description 6 7.1 Overview 6 7.2 Functional Block Diagram 7 7.3 Feature Description..... 7	7.4 Device Functional Modes..... 7 8 Application and Implementation 8 8.1 Application Information..... 8 8.2 Typical Application 8 9 Power Supply Recommendations 9 10 Layout 9 10.1 Layout Guidelines 9 10.2 Layout Example 9 11 Device and Documentation Support 10 11.1 Receiving Notification of Documentation Updates 10 11.2 Community Resources..... 10 11.3 Trademarks 10 11.4 Electrostatic Discharge Caution..... 10 11.5 Glossary 10 12 Mechanical, Packaging, and Orderable Information 10
--	---

4 Revision History

NOTE: Page numbers for previous revisions may differ from page numbers in the current version.

Changes from Revision D (April 2013) to Revision E	Page
• Added <i>ESD Ratings</i> table, <i>Feature Description</i> section, <i>Device Functional Modes</i> , <i>Application and Implementation</i> section, <i>Power Supply Recommendations</i> section, <i>Layout</i> section, <i>Device and Documentation Support</i> section, and <i>Mechanical, Packaging, and Orderable Information</i> section.	1
• Deleted <i>Ordering Information</i> table; see POA at the end of the data sheet.....	1
• Added <i>Thermal Information</i> table	4
• Changed R _{θJA} value From: 478 To: 275.5	4

Changes from Revision C (April 2013) to Revision D	Page
• Changed layout of National Semiconductor Data Sheet to TI format	1

5 Pin Configuration and Functions

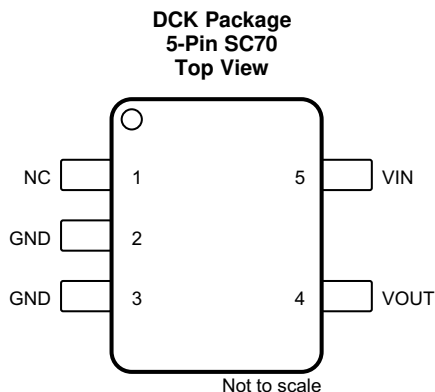

Pin Functions

PIN		I/O	DESCRIPTION
NAME	NO.		
GND	2	—	Internally connected to ground. Can be left floating or connected to GND (pin 3).
GND	3	—	Ground
NC	1	—	No connection
VIN	5	I	Input supply
VOUT	4	O	Voltage output

6 Specifications

6.1 Absolute Maximum Ratings

over operating free-air temperature range (unless otherwise noted)⁽¹⁾

	MIN	MAX	UNIT
Input voltage to GND		8	V
Output voltage to GND		8	V
Output continuous output current		30	mA
Vapor phase IR convection reflow		240	°C
Junction temperature, T _J		150	°C
Storage temperature, T _{stg}	–65	150	°C

(1) Stresses beyond those listed under *Absolute Maximum Ratings* may cause permanent damage to the device. These are stress ratings only, which do not imply functional operation of the device at these or any other conditions beyond those indicated under *Recommended Operating Conditions*. Exposure to absolute-maximum-rated conditions for extended periods may affect device reliability.

6.2 ESD Ratings

		VALUE	UNIT
V _(ESD)	Electrostatic discharge	Human-body model (HBM), per ANSI/ESDA/JEDEC JS-001 ⁽¹⁾	±2500
		Machine model	±200

(1) JEDEC document JEP155 states that 500-V HBM allows safe manufacturing with a standard ESD control process.

6.3 Recommended Operating Conditions

	MIN	MAX	UNIT
T _J	–40	85	°C

6.4 Thermal Information

THERMAL METRIC ⁽¹⁾		LMS33460	
		DCK (SC70)	
		5 PINS	
			UNIT
$R_{\theta JA}$	Junction-to-ambient thermal resistance	275.5	°C/W
$R_{\theta JC(top)}$	Junction-to-case (top) thermal resistance	102.5	°C/W
$R_{\theta JB}$	Junction-to-board thermal resistance	54	°C/W
ψ_{JT}	Junction-to-top characterization parameter	2.7	°C/W
ψ_{JB}	Junction-to-board characterization parameter	53.3	°C/W

(1) For more information about traditional and new thermal metrics, see the [Semiconductor and IC Package Thermal Metrics](#) application report.

6.5 Electrical Characteristics

$T_J = 25^\circ\text{C}$ (unless otherwise noted)

PARAMETER		TEST CONDITIONS	MIN	TYP	MAX	UNIT
V_{DET}	Detector threshold	V_{IN} falling	2.85	3	3.15	V
V_{HYS}	Detector voltage hysteresis	V_{IN} rising	0.095	0.155	0.215	V
I_{IN}	Input supply current	$V_{IN} = 2.87\text{ V}$		1	2.2	μA
		$V_{IN} = 4.7\text{ V}$		1.2	3.6	μA
		$V_{IN} = 7\text{ V}^{(1)}$		25	200	μA
$V_{IN(MAX)}$	Maximum operating voltage				7	V
$V_{IN(MIN)}$	Minimum operating voltage			0.7	1.1	V
		$T_J = -40^\circ\text{C}$ to 85°C		1	1.3	
$I_{OUT(LOW)}$	Output current low	$V_{OUT} = 0.05\text{ V}$, $V_{IN} = 1.1\text{ V}$	0.01	0.6		mA
		$V_{OUT} = 0.5\text{ V}$, $V_{IN} = 1.5\text{ V}$	2	11		
t_{PDHL}	Output delay time (output transition high to low)	$C_L = 10\text{ pF}$, $R_L = 470\text{ k}\Omega$		130	200	μs
$\Delta V_{DET}/\Delta T$	Detect voltage temperature coefficient	$T_J = -40^\circ\text{C}$ to 85°C		± 120		PPM/°C

(1) Quiescent current increases substantially above 5.5 V, but is very low in the normal range below 5.5 V.

6.6 Typical Characteristics

$T_A = 25^\circ\text{C}$, $R_L = 470\text{ k}\Omega$, and $C_L = 10\text{ pF}$ (unless otherwise noted)

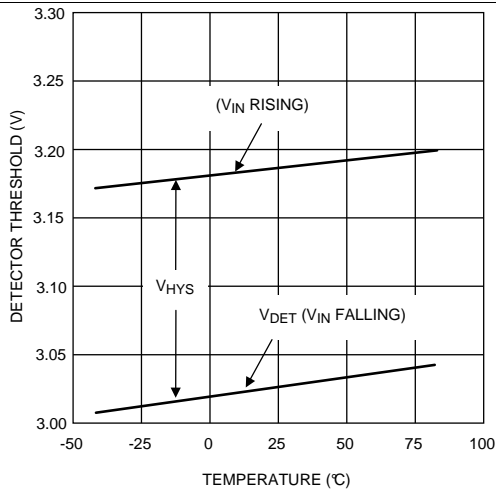

Figure 1. Detector Threshold vs Temperature

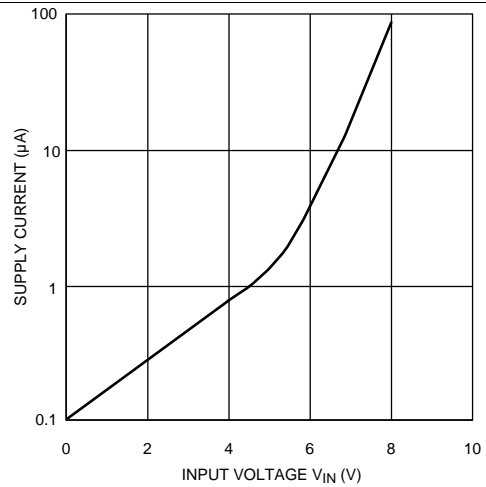

Figure 2. Supply Current vs Input Voltage

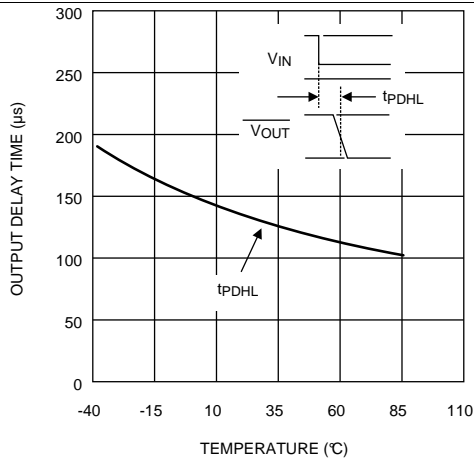

Figure 3. Propagation Delay Time (t_{PDHL}) vs Temperature

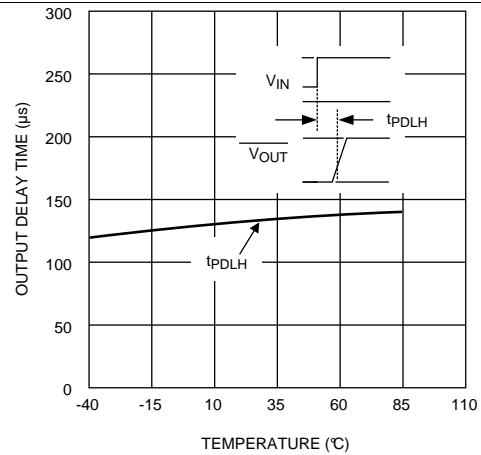

Figure 4. Propagation Delay Time (t_{PDLH}) vs Temperature

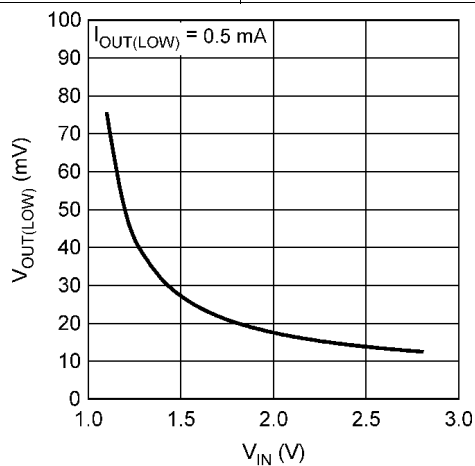

Figure 5. $V_{OUT(LOW)}$ vs V_{IN}

7 Detailed Description

7.1 Overview

The LMS33460 is a micropower undervoltage-sensing circuit with an open-drain output configuration, which requires a pull resistor.

The LMS33460 features a voltage reference, a comparator with precise thresholds and built-in hysteresis to prevent erratic reset operation.

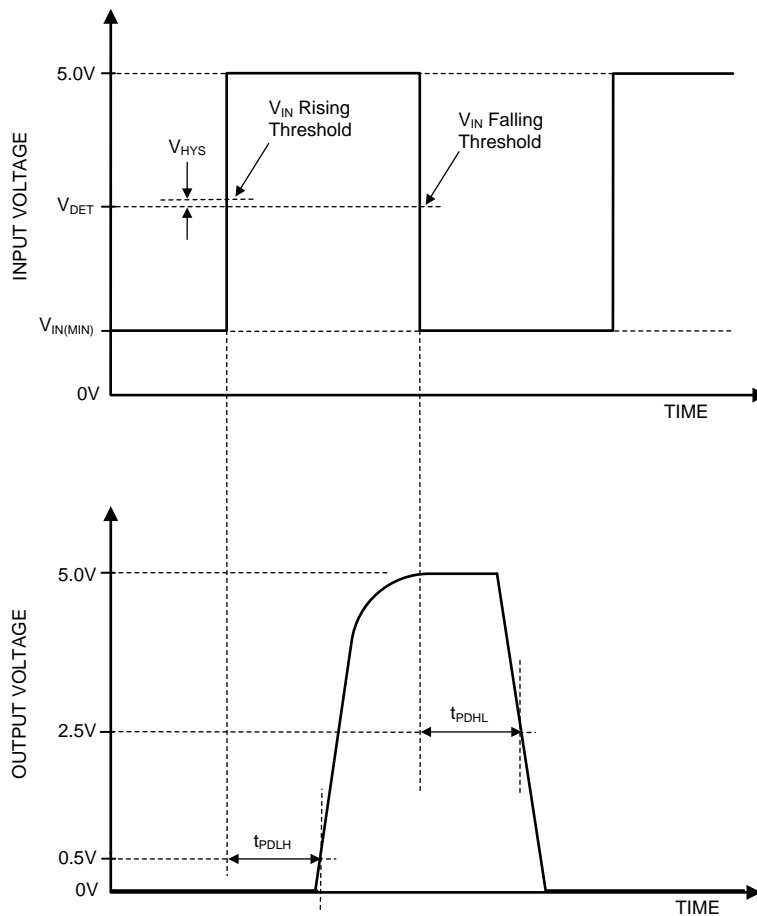
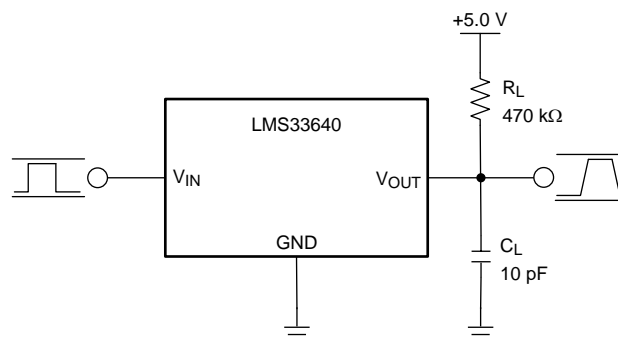

Figure 6. Propagation Delay Timing Diagram



Copyright © 2016, Texas Instruments Incorporated

Figure 7. Propagation Delay Test Circuit

7.2 Functional Block Diagram

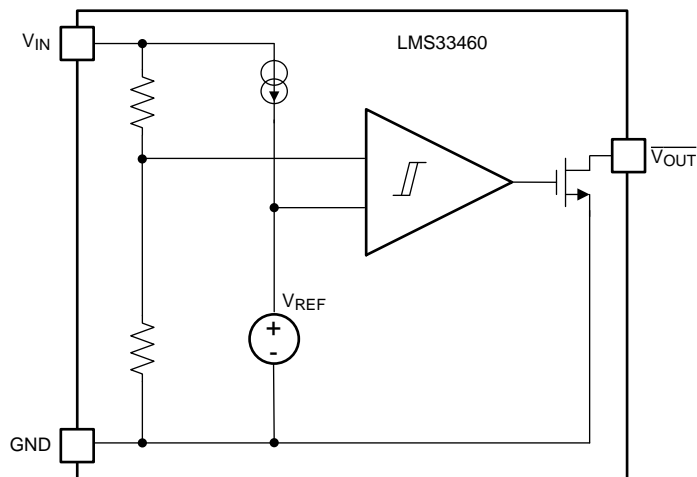

Copyright © 2016, Texas Instruments Incorporated

7.3 Feature Description

The input supply (V_{IN}) is the voltage that is being monitored and as it decreases past 3 V, the active-low output (V_{OUT}) transitions to a logic low state. When V_{IN} rises above 3 V plus the built-in hysteresis, V_{OUT} returns to its original state of logic high. The LMS33460 has built-in hysteresis when the input supply is coming back up to help prevent erratic output operation when the input voltage crosses the threshold.

The LMS33460 is useful in a variety of applications that require low voltage detection and is suited for battery-powered systems where low quiescent current and small package size is required. It can also be used as a precision reset circuit for microcontroller applications.

7.4 Device Functional Modes

7.4.1 Start Up

As the input voltage (V_{IN}) ramps up, the output (V_{OUT}) remains logic low until V_{IN} reaches 3.15 V due to the built-in hysteresis (nominally 150 mV). After V_{IN} crosses that threshold, V_{OUT} remains logic high until V_{IN} drops below the 3-V threshold. The hysteresis only applies to the V_{IN} rising threshold.

8 Application and Implementation

NOTE

Information in the following applications sections is not part of the TI component specification, and TI does not warrant its accuracy or completeness. TI's customers are responsible for determining suitability of components for their purposes. Customers should validate and test their design implementation to confirm system functionality.

8.1 Application Information

This device is ideal to use in battery-powered or microprocessor based systems and can be used as a low voltage indicator or reset circuit.

8.2 Typical Application

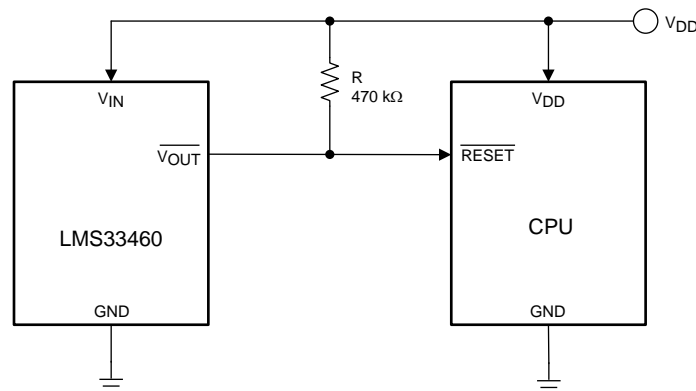

Copyright © 2016, Texas Instruments Incorporated

Figure 8. Typical Application Schematic

8.2.1 Design Requirements

For this design example, use the parameters listed in [Table 1](#) as the input parameters.

Table 1. Design Parameters

PARAMETER	EXAMPLE VALUE
Input supply voltage maximum	7 V
V _{OUT} maximum	7 V
V _{OUT} minimum	0 V
Pullup resistor	470 kΩ

8.2.2 Detailed Design Procedure

The LMS33460 is a very easy to use low voltage detector. All that required is the input supply voltage and a pullup resistor at the output. TI recommends 470 kΩ for the pullup resistor.

8.2.3 Application Curve

$R_L = 475\text{ k}\Omega$

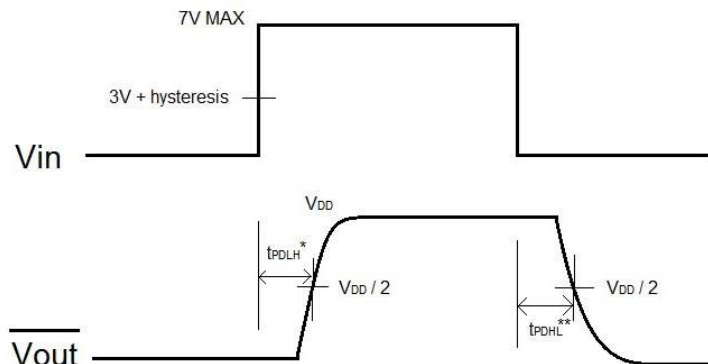

* See Figure 4 for tPDLH values

** See Figure 3 for tPDHL values

Figure 9. LMS33460 Turnon

9 Power Supply Recommendations

The input of the LMS33460 is designed to handle up to the recommended supply voltage of 7 V and remain in the recommended input voltage range during operation. No input capacitor is required.

10 Layout

10.1 Layout Guidelines

Place the output pullup resistor, and delay capacitor if used, as close as possible to the IC. Keep traces short between the IC and the components used at the output to ensure the timing delay is as accurate as possible.

10.2 Layout Example

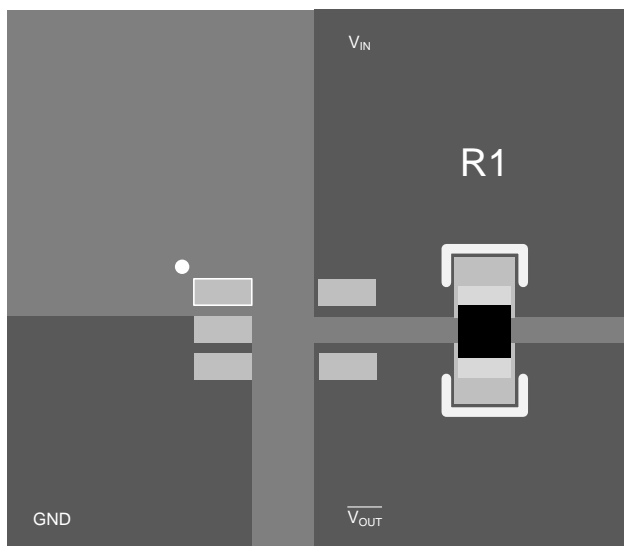

Figure 10. Layout Example Diagram

11 Device and Documentation Support

11.1 Receiving Notification of Documentation Updates

To receive notification of documentation updates, navigate to the device product folder on ti.com. In the upper right corner, click on *Alert me* to register and receive a weekly digest of any product information that has changed. For change details, review the revision history included in any revised document.

11.2 Community Resources

The following links connect to TI community resources. Linked contents are provided "AS IS" by the respective contributors. They do not constitute TI specifications and do not necessarily reflect TI's views; see TI's [Terms of Use](#).

TI E2E™ Online Community *TI's Engineer-to-Engineer (E2E) Community*. Created to foster collaboration among engineers. At e2e.ti.com, you can ask questions, share knowledge, explore ideas and help solve problems with fellow engineers.

Design Support *TI's Design Support* Quickly find helpful E2E forums along with design support tools and contact information for technical support.

11.3 Trademarks

E2E is a trademark of Texas Instruments.
All other trademarks are the property of their respective owners.

11.4 Electrostatic Discharge Caution



This integrated circuit can be damaged by ESD. Texas Instruments recommends that all integrated circuits be handled with appropriate precautions. Failure to observe proper handling and installation procedures can cause damage.

ESD damage can range from subtle performance degradation to complete device failure. Precision integrated circuits may be more susceptible to damage because very small parametric changes could cause the device not to meet its published specifications.

11.5 Glossary

[SLYZ022](#) — *TI Glossary*.

This glossary lists and explains terms, acronyms, and definitions.

12 Mechanical, Packaging, and Orderable Information

The following pages include mechanical, packaging, and orderable information. This information is the most current data available for the designated devices. This data is subject to change without notice and revision of this document. For browser-based versions of this data sheet, refer to the left-hand navigation.

PACKAGING INFORMATION

Orderable Device	Status (1)	Package Type	Package Drawing	Pins	Package Qty	Eco Plan (2)	Lead finish/ Ball material (6)	MSL Peak Temp (3)	Op Temp (°C)	Device Marking (4/5)	Samples
LMS33460MG	LIFEBUY	SC70	DCK	5	1000	Non-RoHS & Green	Call TI	Level-1-260C-UNLIM	-40 to 85	C33	
LMS33460MG/NOPB	ACTIVE	SC70	DCK	5	1000	RoHS & Green	SN	Level-1-260C-UNLIM	-40 to 85	C33	Samples

(1) The marketing status values are defined as follows:

ACTIVE: Product device recommended for new designs.

LIFEBUY: TI has announced that the device will be discontinued, and a lifetime-buy period is in effect.

NRND: Not recommended for new designs. Device is in production to support existing customers, but TI does not recommend using this part in a new design.

PREVIEW: Device has been announced but is not in production. Samples may or may not be available.

OBSOLETE: TI has discontinued the production of the device.

(2) **RoHS:** TI defines "RoHS" to mean semiconductor products that are compliant with the current EU RoHS requirements for all 10 RoHS substances, including the requirement that RoHS substance do not exceed 0.1% by weight in homogeneous materials. Where designed to be soldered at high temperatures, "RoHS" products are suitable for use in specified lead-free processes. TI may reference these types of products as "Pb-Free".

RoHS Exempt: TI defines "RoHS Exempt" to mean products that contain lead but are compliant with EU RoHS pursuant to a specific EU RoHS exemption.

Green: TI defines "Green" to mean the content of Chlorine (Cl) and Bromine (Br) based flame retardants meet JS709B low halogen requirements of <=1000ppm threshold. Antimony trioxide based flame retardants must also meet the <=1000ppm threshold requirement.

(3) MSL, Peak Temp. - The Moisture Sensitivity Level rating according to the JEDEC industry standard classifications, and peak solder temperature.

(4) There may be additional marking, which relates to the logo, the lot trace code information, or the environmental category on the device.

(5) Multiple Device Markings will be inside parentheses. Only one Device Marking contained in parentheses and separated by a "-" will appear on a device. If a line is indented then it is a continuation of the previous line and the two combined represent the entire Device Marking for that device.

(6) Lead finish/Ball material - Orderable Devices may have multiple material finish options. Finish options are separated by a vertical ruled line. Lead finish/Ball material values may wrap to two lines if the finish value exceeds the maximum column width.

Important Information and Disclaimer:The information provided on this page represents TI's knowledge and belief as of the date that it is provided. TI bases its knowledge and belief on information provided by third parties, and makes no representation or warranty as to the accuracy of such information. Efforts are underway to better integrate information from third parties. TI has taken and continues to take reasonable steps to provide representative and accurate information but may not have conducted destructive testing or chemical analysis on incoming materials and chemicals. TI and TI suppliers consider certain information to be proprietary, and thus CAS numbers and other limited information may not be available for release.

In no event shall TI's liability arising out of such information exceed the total purchase price of the TI part(s) at issue in this document sold by TI to Customer on an annual basis.

TAPE AND REEL INFORMATION

QUADRANT ASSIGNMENTS FOR PIN 1 ORIENTATION IN TAPE

*All dimensions are nominal

Device	Package Type	Package Drawing	Pins	SPQ	Reel Diameter (mm)	Reel Width W1 (mm)	A0 (mm)	B0 (mm)	K0 (mm)	P1 (mm)	W (mm)	Pin1 Quadrant
LMS33460MG	SC70	DCK	5	1000	178.0	8.4	2.25	2.45	1.2	4.0	8.0	Q3
LMS33460MG/NOPB	SC70	DCK	5	1000	178.0	8.4	2.25	2.45	1.2	4.0	8.0	Q3

TAPE AND REEL BOX DIMENSIONS

*All dimensions are nominal

Device	Package Type	Package Drawing	Pins	SPQ	Length (mm)	Width (mm)	Height (mm)
LMS33460MG	SC70	DCK	5	1000	208.0	191.0	35.0
LMS33460MG/NOPB	SC70	DCK	5	1000	208.0	191.0	35.0

EXAMPLE BOARD LAYOUT

DCK0005A

SOT - 1.1 max height

SMALL OUTLINE TRANSISTOR

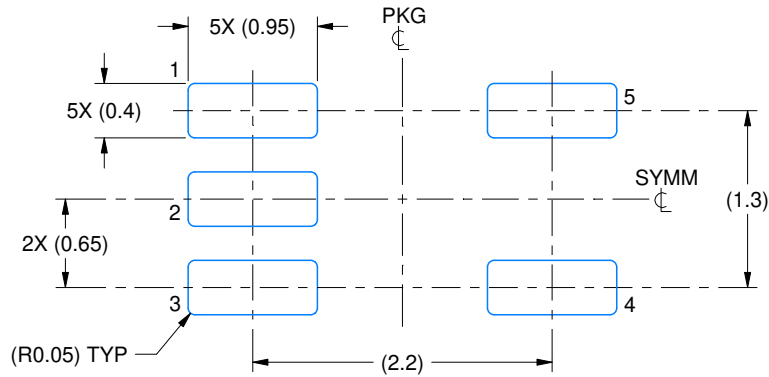

LAND PATTERN EXAMPLE
EXPOSED METAL SHOWN
SCALE:18X

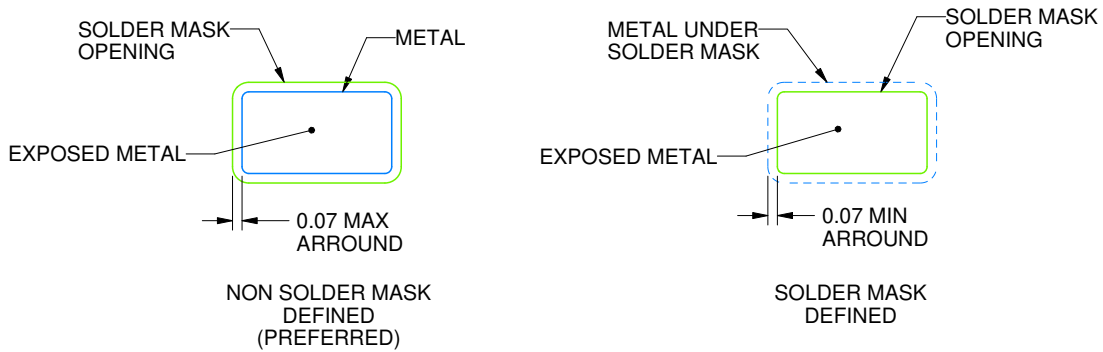

SOLDER MASK DETAILS

4214834/C 03/2023

NOTES: (continued)

- 4. Publication IPC-7351 may have alternate designs.
- 5. Solder mask tolerances between and around signal pads can vary based on board fabrication site.

EXAMPLE STENCIL DESIGN

DCK0005A

SOT - 1.1 max height

SMALL OUTLINE TRANSISTOR

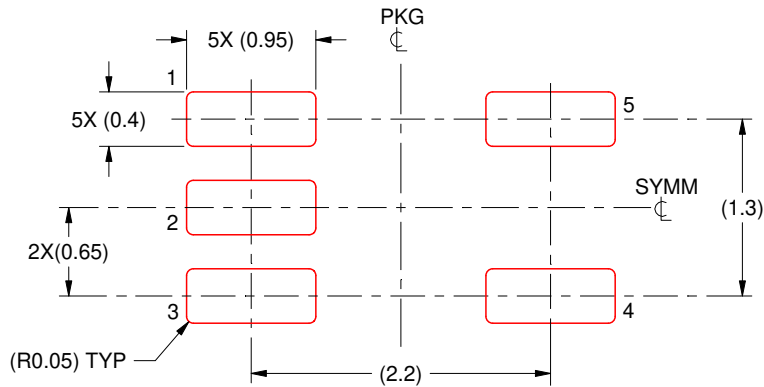

SOLDER PASTE EXAMPLE
BASED ON 0.125 THICK STENCIL
SCALE:18X

4214834/C 03/2023

NOTES: (continued)

6. Laser cutting apertures with trapezoidal walls and rounded corners may offer better paste release. IPC-7525 may have alternate design recommendations.
7. Board assembly site may have different recommendations for stencil design.

IMPORTANT NOTICE AND DISCLAIMER

TI PROVIDES TECHNICAL AND RELIABILITY DATA (INCLUDING DATA SHEETS), DESIGN RESOURCES (INCLUDING REFERENCE DESIGNS), APPLICATION OR OTHER DESIGN ADVICE, WEB TOOLS, SAFETY INFORMATION, AND OTHER RESOURCES "AS IS" AND WITH ALL FAULTS, AND DISCLAIMS ALL WARRANTIES, EXPRESS AND IMPLIED, INCLUDING WITHOUT LIMITATION ANY IMPLIED WARRANTIES OF MERCHANTABILITY, FITNESS FOR A PARTICULAR PURPOSE OR NON-INFRINGEMENT OF THIRD PARTY INTELLECTUAL PROPERTY RIGHTS.

These resources are intended for skilled developers designing with TI products. You are solely responsible for (1) selecting the appropriate TI products for your application, (2) designing, validating and testing your application, and (3) ensuring your application meets applicable standards, and any other safety, security, regulatory or other requirements.

These resources are subject to change without notice. TI grants you permission to use these resources only for development of an application that uses the TI products described in the resource. Other reproduction and display of these resources is prohibited. No license is granted to any other TI intellectual property right or to any third party intellectual property right. TI disclaims responsibility for, and you will fully indemnify TI and its representatives against, any claims, damages, costs, losses, and liabilities arising out of your use of these resources.

TI's products are provided subject to [TI's Terms of Sale](#) or other applicable terms available either on [ti.com](https://www.ti.com) or provided in conjunction with such TI products. TI's provision of these resources does not expand or otherwise alter TI's applicable warranties or warranty disclaimers for TI products.

TI objects to and rejects any additional or different terms you may have proposed.

Mailing Address: Texas Instruments, Post Office Box 655303, Dallas, Texas 75265
Copyright © 2023, Texas Instruments Incorporated