

P	U/R	DESCRIPTION	DATE	OWN	APP'D
B		REVISED PER ECO-21-002295	18FEB2021	ES	SZ

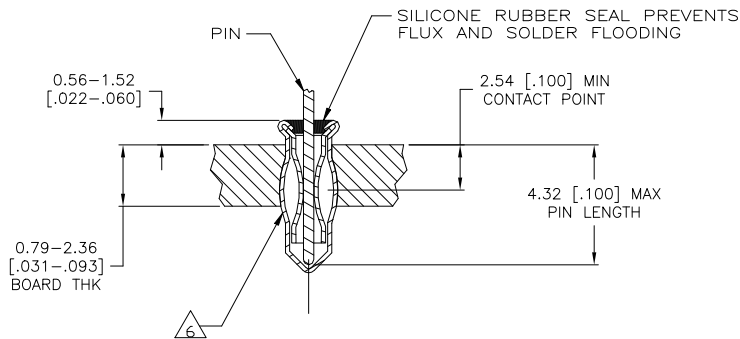
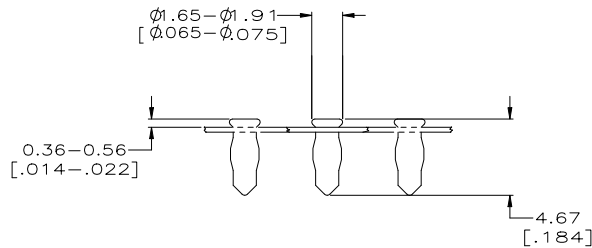
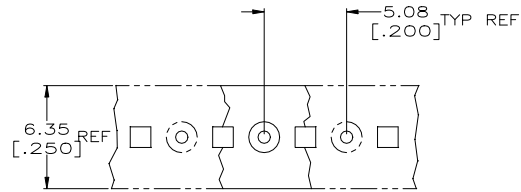

- 1 MATERIAL:
EYELET - COPPER PER ASTM B 152
SPRING - BERYLLIUM COPPER PER ASTM B 194
SEALANT - SILICONE RUBBER
- 2 TIN PLATE PER ASTM B 545, 0.00254 [.000100] MIN THK.
- 3 GOLD PLATE PER ASTM B 488, 0.00076 [.000030] MIN THK ON CONTACT AREA.
- 4 PACKAGED, 50,000 PER REEL
- 5 TO INSURE 1/2 OZ MIN RETENTION DO NOT EXCEED 0.10 [.004] DIFFERENCE IN PIN DIA WHEN CHANGING TO A SMALLER DIA PIN
- 6 PRODUCT IS OVALIZED FOR RETENTION IN THE P.C. BOARD. THE RECOMMENDED HOLE DIAMETER IS Ø1.32 [Ø.052] MINIMUM, +0.08 [.003] MAX. PRIOR TO SOLDERING.
- 7 PACKAGED, 10,000 PER REEL
- 8 LOOSE PIECE PACKAGED

OBSOLETE	2.54-4.32 [.100-.170]	Ø0.36-Ø0.66 [Ø.014-Ø.026]	TIN 2	TIN 2	8-2-5645955-1
	2.54-4.32 [.100-.170]	Ø0.36-Ø0.66 [Ø.014-Ø.026]	GOLD 3	TIN 2	1-5645955-2
	2.54-4.32 [.100-.170]	Ø0.36-Ø0.66 [Ø.014-Ø.026]	TIN 2	TIN 2	1-5645955-1
	2.54-4.32 [.100-.170]	Ø0.36-Ø0.66 [Ø.014-Ø.026]	GOLD 3	TIN 2	5645955-2
	LENGTH	DIA 5	SPRING	EYELET	PART NO.

THIS DRAWING IS A CONTROLLED DOCUMENT.		DWG: J. POLIGNONE 25JAN06	TE TE Connectivity		
DIMENSIONS: mm (INCHES)		CHK: J. HAVENER 25JAN06			
TOLERANCES UNLESS OTHERWISE SPECIFIED:		APPR: J. HAVENER 25JAN06	NAME: MINIATURE SPRING SOCKET ASSY SERIES 2 LONG WITH SEALANT		
0 PLC ± -	1 PLC ± -	PRODUCT SPEC: 108-14008	RESTRICTED TO		
2 PLC ± -	3 PLC ± 0.20(008)	APPLICATION SPEC: 114-26004	SIZE: A2	CAGE CODE: 00779	DRAWING NO: C=5645955
4 PLC ± -	ANGLES ± A	WEIGHT: 0	SCALE: 1:1 SHEET: 1 of 1 REV: B		
MATERIAL: 1 SEE TABLE		CUSTOMER DRAWING			